

**REPAIR
HANDBOOK**

CLAAS

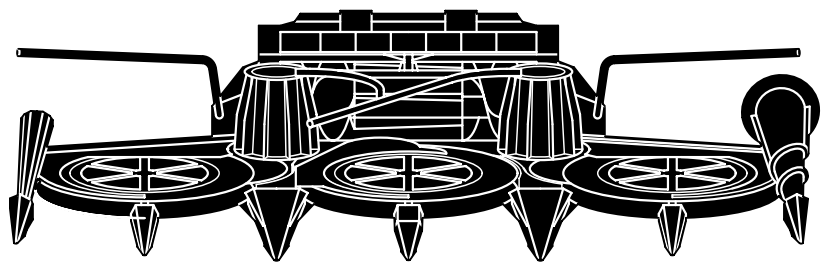

**CLAAS
RU 450**

CLICK HERE TO **DOWNLOAD** THE COMPLETE MANUAL

- Thank you very much for reading the preview of the manual.
- You can download the complete manual from: www.heydownloads.com by clicking the link below



- Please note: If there is no response to CLICKING the link, please download this PDF first and then click on it.

CLICK HERE TO **DOWNLOAD** THE COMPLETE MANUAL

INTRODUCTION TO THE CLAAS REPAIR MANUAL

The chapters of the CLAAS Repair Manual correspond to the order of the CLAAS spare part list.

The pictures and pages in each chapter begin with one and are numbered consecutively. The numbering at the bottom of each page is made up of the first number of the main group and the page number which follows the period.

Those assembly processes which only apply to certain machine types are marked with type-related details while the assembly processes that apply to all of the machine types dealt with in this manual remain neutral.

The order of the entries is given using an additional number which is shown using a dash after the page number. Entries received later are fixed to the respective main group and the respective Table of Contents is exchanged.

The picture references are used as a quick orientation for recurring assembly processes. The explanation of the picture references is at the beginning of the manual.

Informative explanations are at the beginning of the manual under the heading "General repair information" Please read and follow this information. The information is the basis for a safe and lasting operation after a repair has been made.

ESPECIALLY IMPORTANT

The information in the operation manual must be read and followed by all persons who use, maintain, repair, or examine this machine to prevent any danger.

Be sure to especially read the section "For your safety" in the CLAAS Repair Manual.

Usage of spare parts, accessories, and attachments which do not originally come from CLAAS and are not tested and allowed by CLAAS could negatively impact the constitutive characteristics of the CLAAS machine or its functional capabilities. This may impair the active/or passive operating safety as well as the operational safety (accident protection).

CLAAS assumes no liability for damage resulting from the use of non-CLAAS original parts, accessories, and attachments.

Technical information, measurements, and weights are not binding. Technical information, measurements, and weights agree with the respective tolerances.

In front, behind, right, and left are always in the direction of motion.

Identification plate

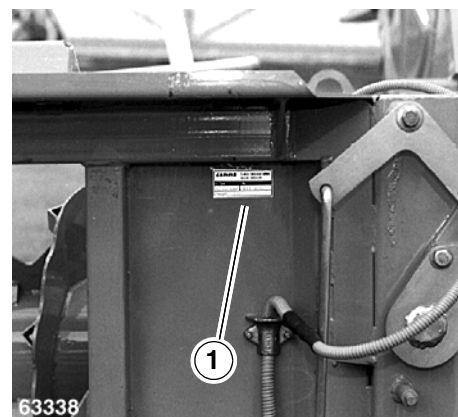

1
The identification plate 1 with the machine number is located on the right side on the rear panel.

(Fig. 1)

Provide the machine number, the type, and the series number whenever spare parts are ordered or for technical questions. This is required to prevent - wrong deliveries.

GENERAL INFORMATION FOR REPAIRS

1. Determine what was responsible for the damage, define the damage claim, and secure the machine.
2. Use original CLAAS spare parts and the respective CLAAS special tool.
3. When dismantling the gearbox, first drain the oil and then remove the gearbox. Separate the parts which are fit into one another with a soft metal or plastic hammer.
4. Adjusting the roller chain tension:

Steel roller chains have the correct tension when you can push with your thumb in the middle of the roller chain between the axles and approx. 2% of play results. Test the stretching or new chains more frequently.

Example: Distance between axle 500 mm =
Approx. 10 mm of displacement.

5. **Tapered ring connections:**

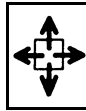
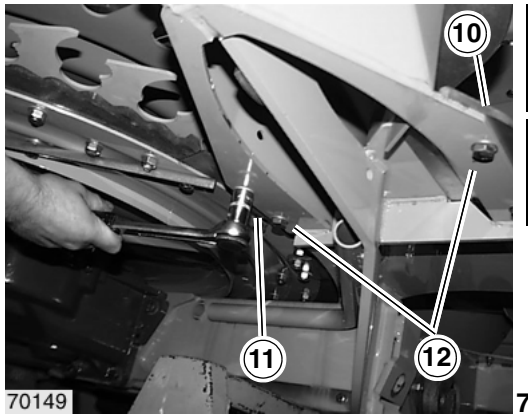

Replacing the feed shear bar.

The feed shear bars are screwed in on the left and right side a total of 4 times under the front frames.

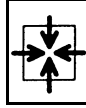

Note: Fold up the side arms to take out the feed shear bars.

Screw on the new shear bars (for example (11) each using 2 hexagon head screws M10x16 (12) and contact washers A10.

Placement of the shear bars:

- outside left = 992 176.0 left (10)
- outside left = 992 175.0 left (11)
- inside right = 996 601.0
- outside right = 992 177.0 right

(Fig. 7)

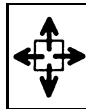
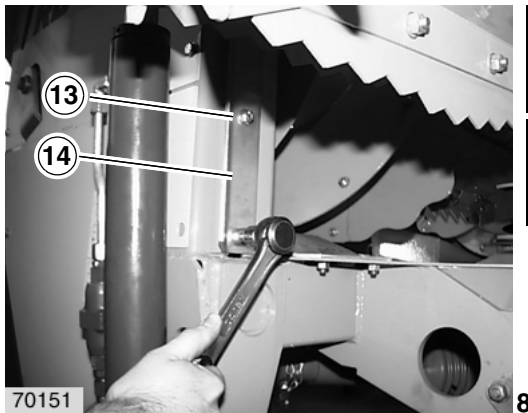

Changing and installing the guide plates

The guide plates (14) are located fastened on the left and right side on the front side of the auger trough.

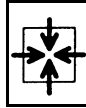

Note: Fold up the side arms to unscrew or install the guide plate.

Screw on each guide plate (14) using 3 hexagon head screws (13) M8x16 and contact washers A8.

Note Align the guide plates according to the feeder cone, the edge must point outwards. The exact adjustment can only be done in the working position.

(Fig. 8)

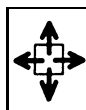
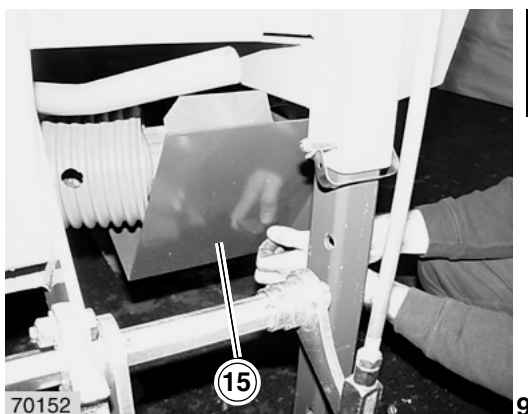

Replacing the feed plates

The feed plates are located on the left and right on the bottom of the auger trough.

In order to assemble/disassemble on the right side of the feed plate, the right protection cover (see Abb. 1) and the safety guard (15) must be taken off.

(Fig. 9) shows the disassembly of the safety guard (15) under the auger trough.

(Fig. 9)

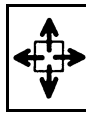
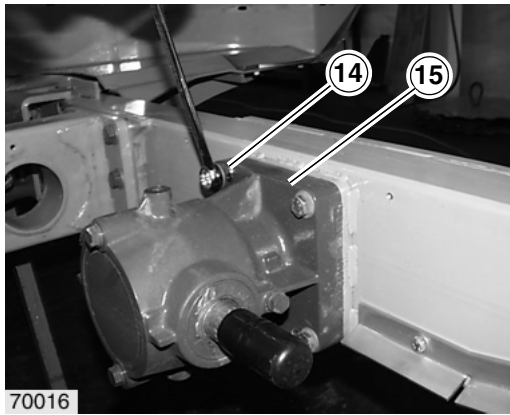

Removing the angular transmission and the tapered clutch.

The angular transmission is removed by loosening and unscrewing the 4 hexagon head screws M12 (14) on the angular transmission flange (15). The tapered clutch is fastened on the drive shaft of the angular transmission.

(Fig. 16)

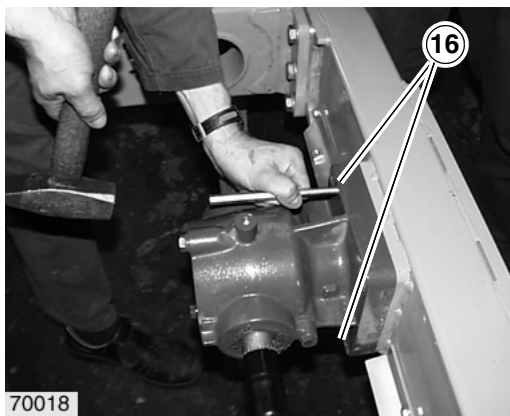

After unscrewing the screws, knock through the two expansion pins (16) on the transmission flange inwards to free up the angle drive.

(Fig. 17)

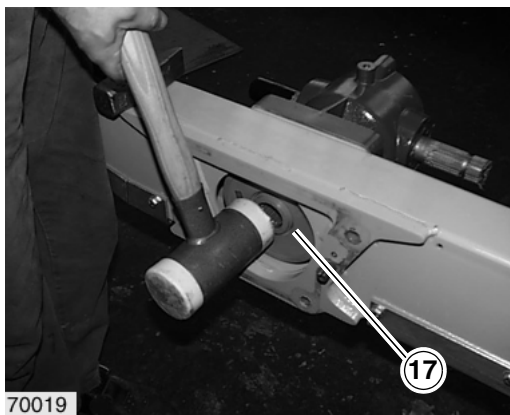

Once the rotor transmission has been removed, knock the angular transmission from its position with blows from a plastic hammer on the tapered clutch (17).

(Fig. 18)

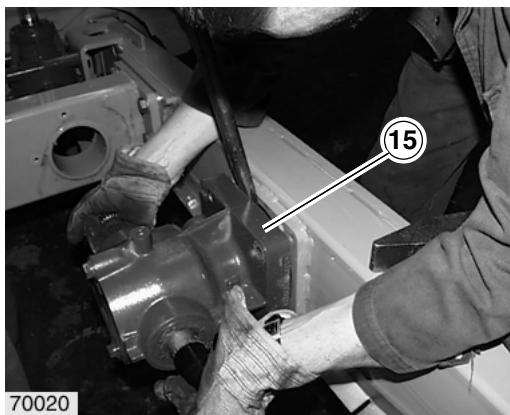

If the rotor transmission is still built in, loosen the angular transmission by leveraging the transmission flange.

Have your assistant secure the angular transmission (15). Pull off the angular transmission together with the tapered clutch from the rotor transmission shaft.

(Fig. 19)

Note: Transmission repair see Chapter: 7.10/1

INTERMEDIATE POINTS

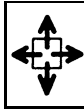
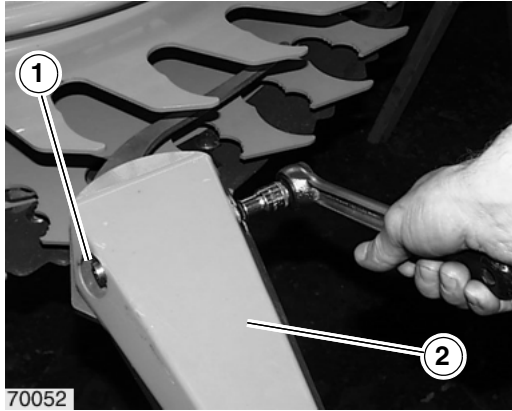

Removing/installing the intermediate points

Removing: Loosen the cylinder screws (1) on the left and right side of the intermediate points (2). Take off the intermediate points.

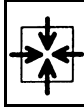

Installing: Screw on the new or reworked intermediate points (2) onto the bracket using the cylinder screws M12x20 (1), the bushings 32Hpx15, and the new circlips Vskz 12.

(Fig. 1)

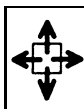
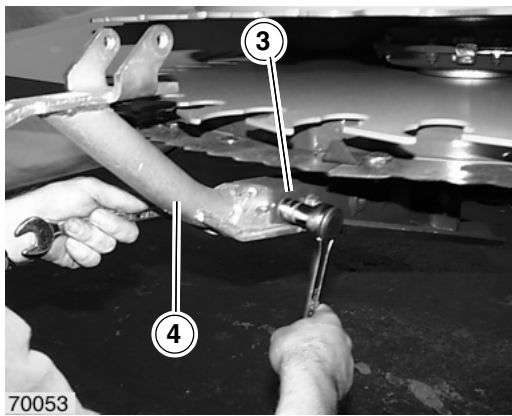

Removing/installing the support to the intermediate points.

Removing: Take out the 2 hexagon head screws (3) on the support-sliding skid connection, and then take the support(4) off.

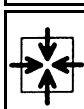

Installing: Install the new or straightened support using 2 hexagon head screws M10x80, contact washers A10, and self-locking nuts VM10.

(Fig. 2)

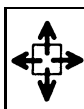
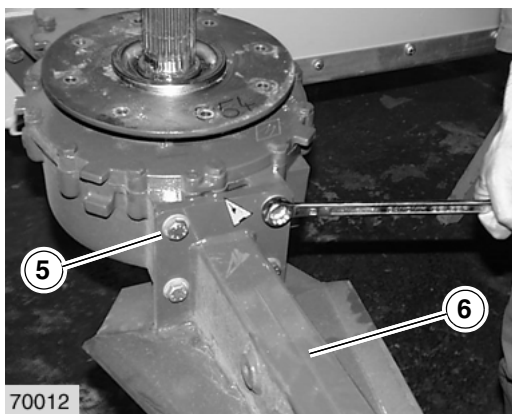

Removing/putting on the sliding skid

Removing the sliding skid: Unscrew the 4 hexagon head screws (5) on the retaining plate from the rotor transmission and lift off the sliding skid (6).

Note: The sliding skid can also be taken off from below when the knives and clearing disks are assembled.

(Fig. 3)

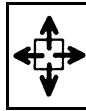
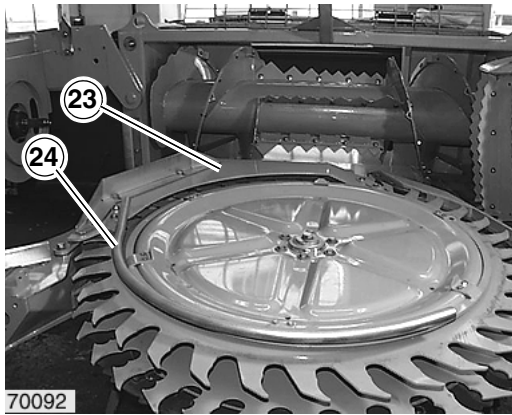

Removing/putting on the upper intake plates

Removing:

Completely take off the cover (23) with tube (24), see Chapter 6.1/4.

Disassemble the inside left and right feeder segments, see Chapter 2.1/2.

(Fig. 25)



Loosen and take out the hexagon head screws (25) in the middle and take them out.

Keep the hexagon screws and washers nearby for re-assembly.

(Fig. 26)

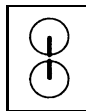
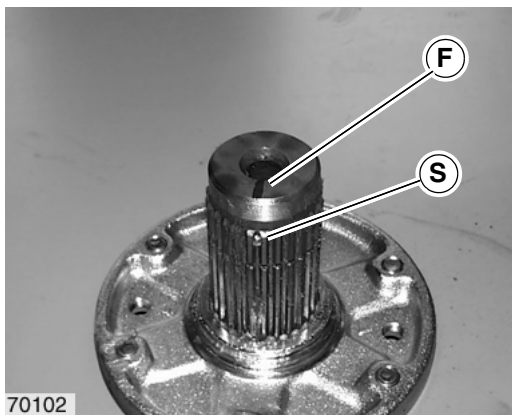

Note: Mark the position of the flange (F) to the rotor transmission shaft to make the re-assembly easier. In the hub, a pair of recesses are in the shaft section. A pin (S) is placed in the shaft here.

Lift off the upper intake plate (26).

Note: An assistant is needed to do this.

(Fig. 27-28)

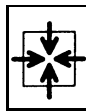
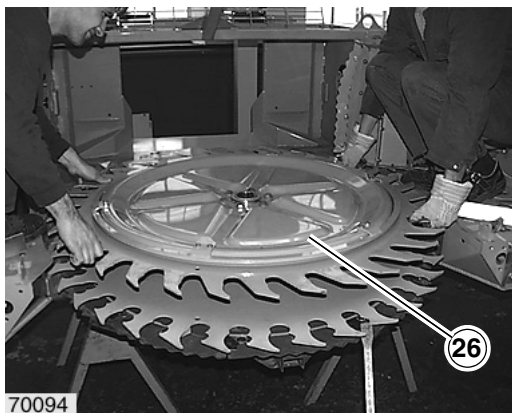

Installation:

The installation is completed exactly in the opposite order as the disassembly, pay attention to the following:

1. Grease the teeth on the inside of the flange.
2. Pay attention to the shaft section (disassembly marking).
3. Tighten the middle screws (25) M16x70 with a torque wrench. Torque setting according to table on Page 1.4/3.
4. Put back on the disassembled feeder segments.

(Fig. 28)

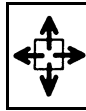
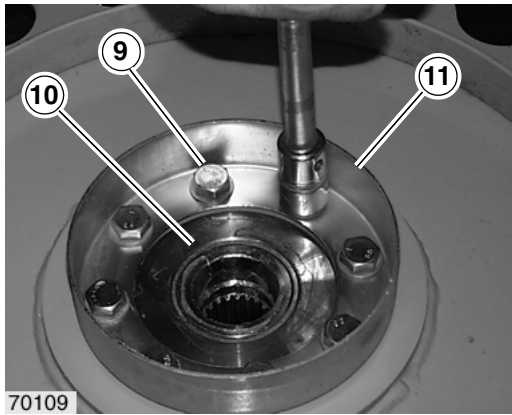

Replacing the overload clutch

Removing: Turn the intake taper.

Loosen and take out the 8 hexagon head screws (9).

Take off the overload clutch (10) and the seal flange (11).

(Fig. 7)

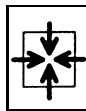
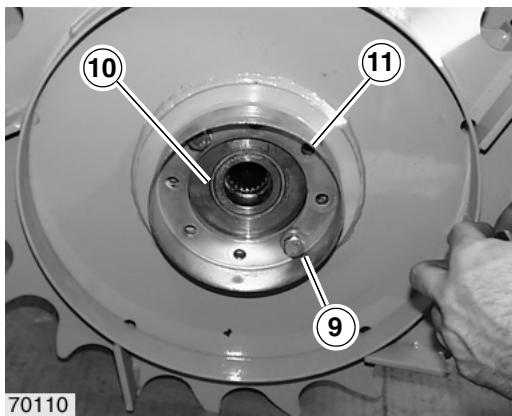

Putting on: Guide a new overload clutch (10) inside into the intake taper and tighten from the outside with the seal flange (11).

Use 8 hexagon head screws (9) M10x25 with contact washers A10 to do this.

Tighten the screws with a torque wrench. Torque setting according to table on Page 1.4/3.

(Fig. 8)

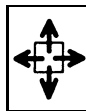
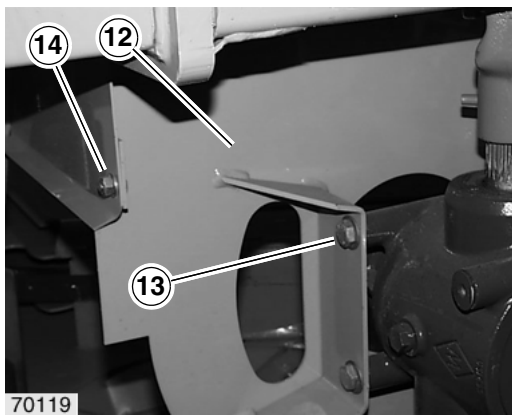

Removing/putting on the outside chamber bottom.

The removal/installation is easiest with a folded up supporting arm.

Removing:

Fasten the left and right outside chamber bottoms (12) each with 2 hexagon head screws M12 (13) from under the angular transmission.

A pan-head screw M8 (14) is located below.

(Fig. 9)

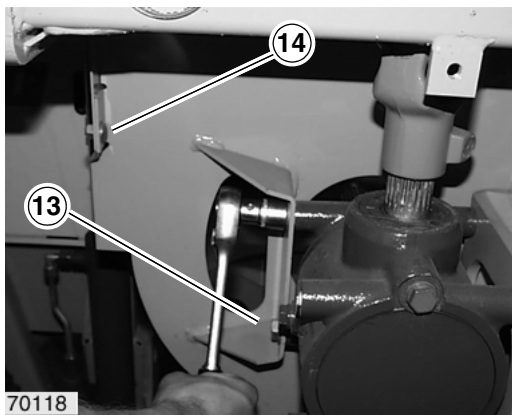

First loosen and remove the screws (13) and (14) from below.

(Fig. 10)

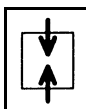
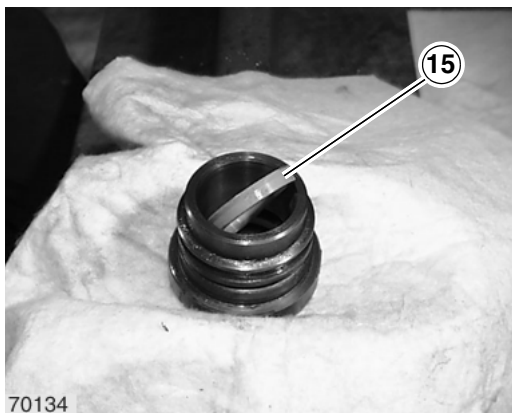

Putting the cylinder back together

First of all, put new seals on the cylinder head:

1. Dirt scraper 35x43x7 (16)
2. Seal 35x43x6 (15)

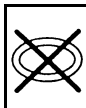

The dirt scraper (16) must sit on the cylinder outlet. the seal inward (15).

Note: The plastic seals or seals must be heated in a water bath at 80° C before they are put on. If this is not done it will lead to damage of the seals during installation.

(Fig. 16-17)

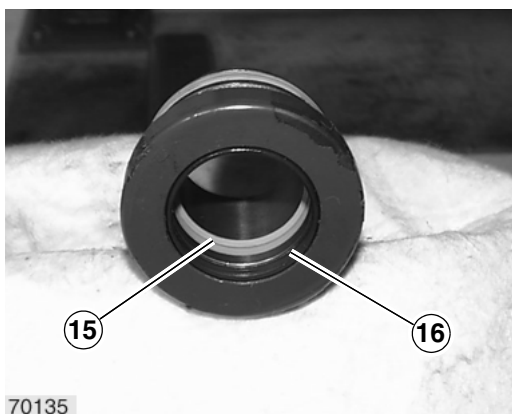

Check for the correct position of the installed seals. Slightly oil all seals.

(Fig. 17)

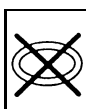
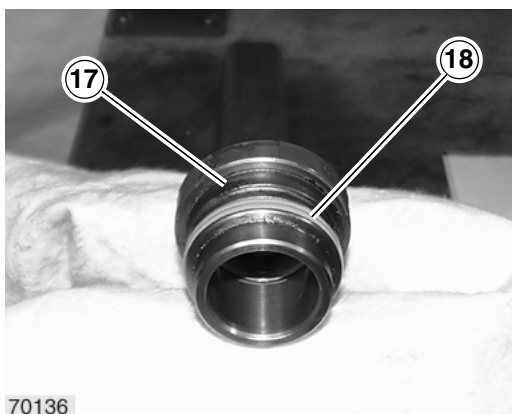

Then install the outer O-ring (17) and the seal (18) (Back ring 46x51.5x1.5) on the cylinder head.

(Fig. 18)

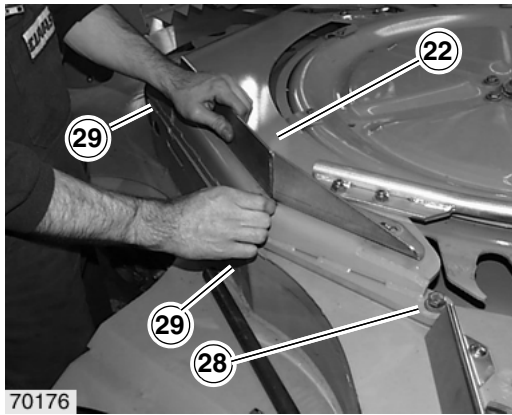

17

Place the hood (22) completely on the shim (27 / Figure 16).

Screw in a hexagon head screw M12x20 (28) with contact washer A12.

Screw in behind 2 hexagon head screws M12x90 (29) with contact washer A12.

(Fig. 17)

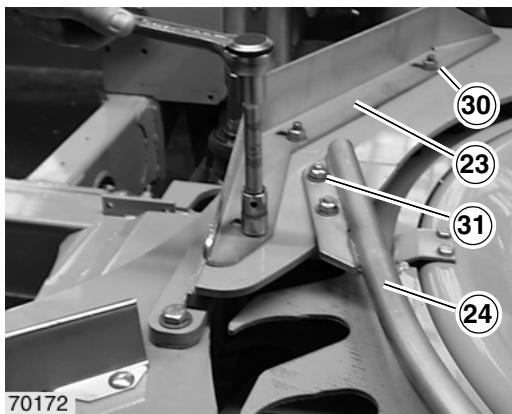

18

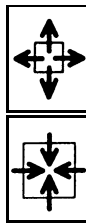

Removing/putting in the guide (23):

To do this, the hood must be removed because the pan-head screws are screwed in from the bottom.

Removing: Unscrew the 3 self-locking nuts (30) and take off the guide(23).

Putting on: Set the guide (23) on and screw in the 3 self-locking nuts M10 (30) with contact washers A10 on the pan-head screws M10x30 and slightly tighten. Align the guide in the slotted holes completely outward and tighten the screws.

Removing/putting in the pipe (24):

Removing: Unscrew the self-locking nuts (31) and take off the pipe(24).

Putting on: Set the pipe (24) on and screw in the 2 self-locking nuts M10 (31) with contact washers A10 on the pan-head screws M10x30 and slightly tighten.

(Fig. 18)



19

Removing/putting in the guide plate (25):

To do this, the hood must be removed because the counter-sunk screws are screwed in from the bottom, see description on Page 13.4.

Note: The guide plate (25) must press onto the upper intake plate with a pressure of no more/less than 15 kp. For installation, support the hood properly (22) (Figure 17) on the shim (27 / Figure 16).

(Fig. 19)



Complete pre-assembled and installed intermediate points, with left touch sensor.

Note: The sensor arm must move freely in the slot for the intermediate points.

(Fig. 8)

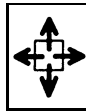
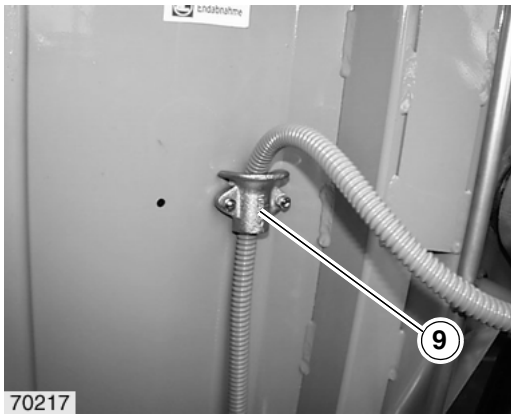

Removing/putting in the wiring harness

Removing the wire harness:

- Loosen the cable clips (9) on the auger trough.
- Loosen the plug on the touch sensors.
- Loosen the cable clips on the divider- or intermediate points.
- Remove the intermediate points with the holder.
- Remove the middle sliding skid.
- Pull out the cable harness from behind the machine.

(Fig. 9)

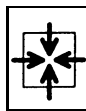
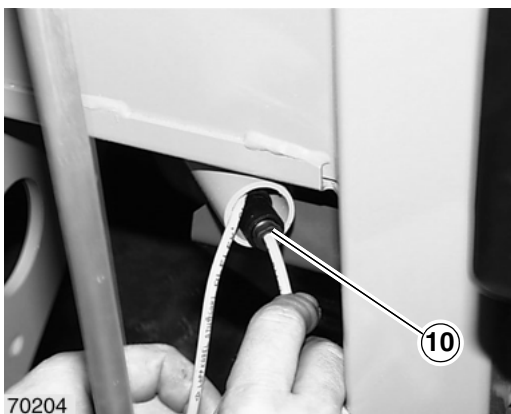

Installing the cable harness:

Preparation if retrofitting:

- Remove the intermediate points with the holder.
- Remove the middle sliding skid.
- Putting in the cable tube.

Stick in both plugs (10) for the connection to the sensor system individually one after another into the protective tube which is on the right underneath on the auger trough.

Pull the cable harness through.

(Fig. 10)

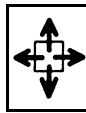
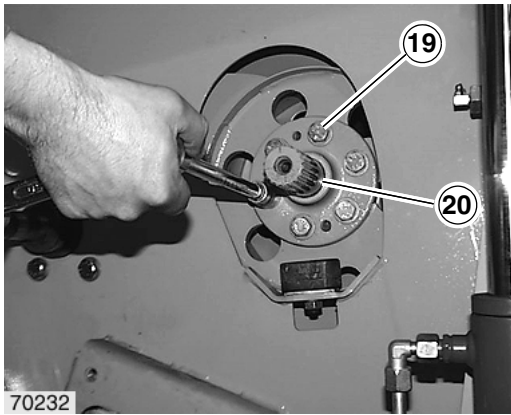

Removing the feeder auger

Requirement: the hub in the middle must be disassembled, see Chapter 6.1/4.

Mark the position of the flange bearing plug (20) on the right side of the auger.

Unscrew and take out the hexagon screws (19) of the flange bearing plug (20).

(Fig. 17)

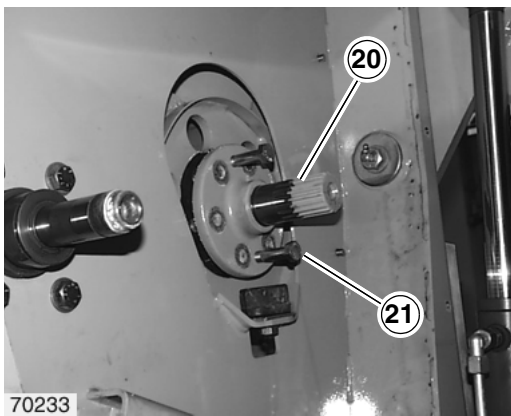

Pull the flange bearing plug (20) out of the auger with 2 forcing screws M10 (21).

(Fig. 18)

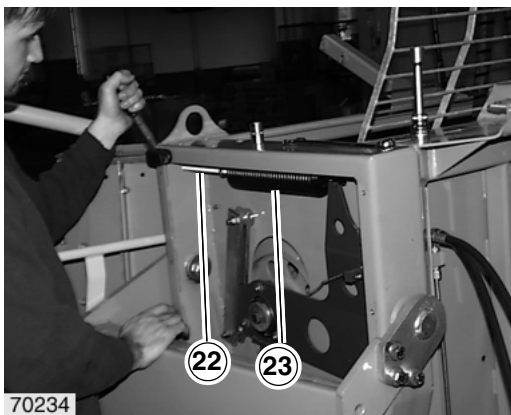

Remove the bearing of the auger on the left side of the auger trough. To do this, lessen the tension of the hexagon screws (22) on the tension ring (23). Hang out the tension ring.

(Fig. 19)

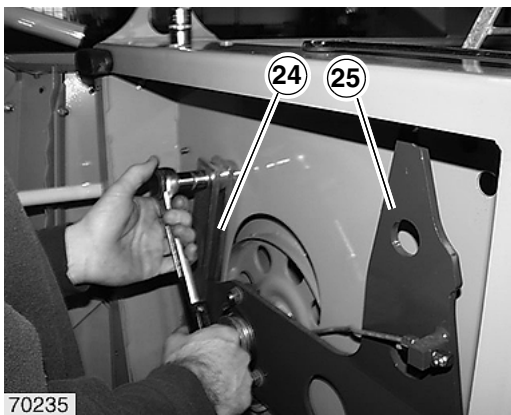

Unscrew the braces (24) to the guide of the left pivot arm (25)

(Fig. 20)

CLICK HERE TO **DOWNLOAD** THE COMPLETE MANUAL

- Thank you very much for reading the preview of the manual.
- You can download the complete manual from: www.heydownloads.com by clicking the link below



- Please note: If there is no response to CLICKING the link, please download this PDF first and then click on it.

CLICK HERE TO **DOWNLOAD** THE COMPLETE MANUAL

KNIFE DRIVE

Removing/installing the entering transmission

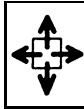

Removing the entering transmission

Take off the joint protection (1) from under the left auger trough. Tighten with 3 hexagon head screws M8.

(Fig. 1)

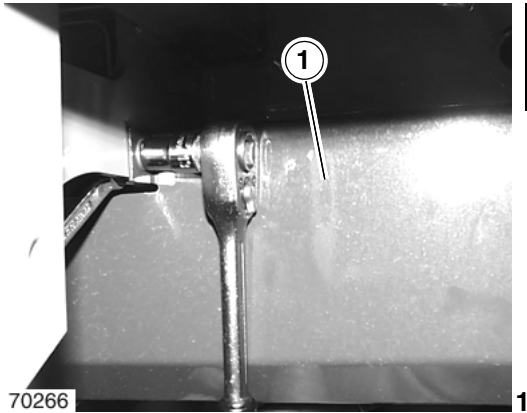

70266

1

Take out the double universal drive (2) between the entering transmission and main transmission. To do this, push the locking pin and the double universal drive as far as possible towards the main transmission to free up the hub fork.

(Fig. 2)

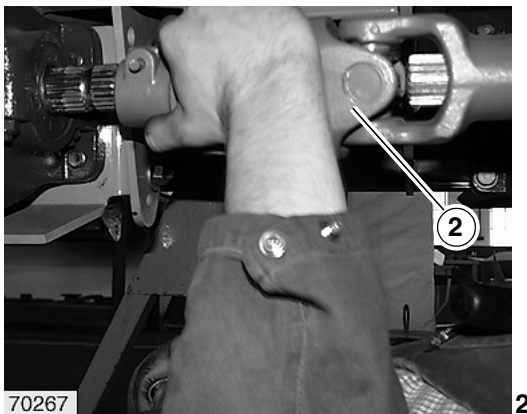

70267

2

Loosen and take out the mounting bolts (3) on the transmission support (4).

As an alternative, the transmission can be taken apart also with the transmission support. Remove the 4 screws (5) to do this.

Note: Have your assistant keep hold of the entering transmission!

(Fig. 3)

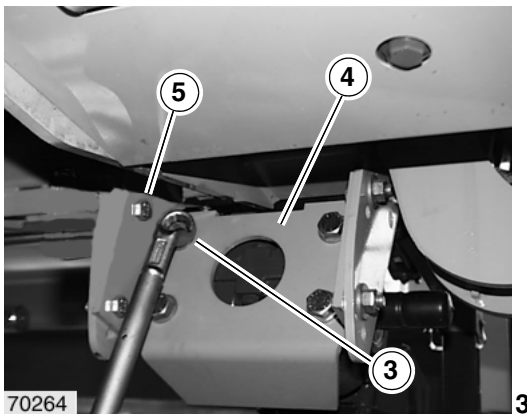

70264

3

Lift off the entering transmission (6) from the transmission support.

(Fig. 4)



70268

4

MAIN TRANSMISSION (B)

Taking apart the main transmission

Drain the transmission oil and let drip!



Environment!

Dispose of oil and grease properly.

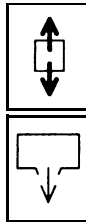
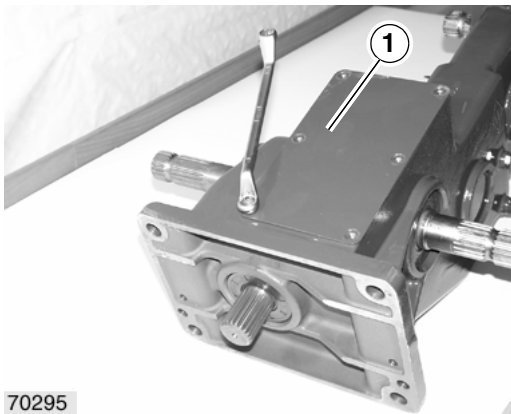

Unscrew the cover (1) above on the transmission case.

(Fig. 1)

70295

1

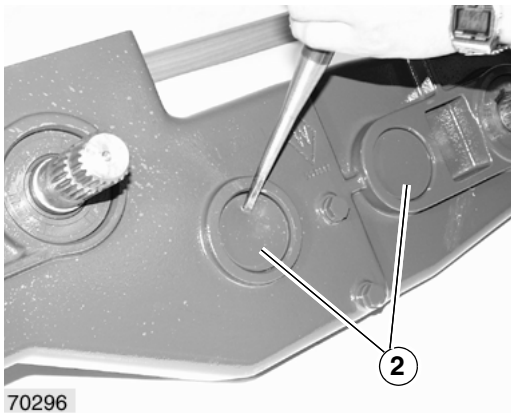

Remove the cap (2) from the complete transmission.

Note: Use a flat screw driver or similar tool. Do not push in too far to prevent damage to the bearings.

(Fig. 2)

70296

2

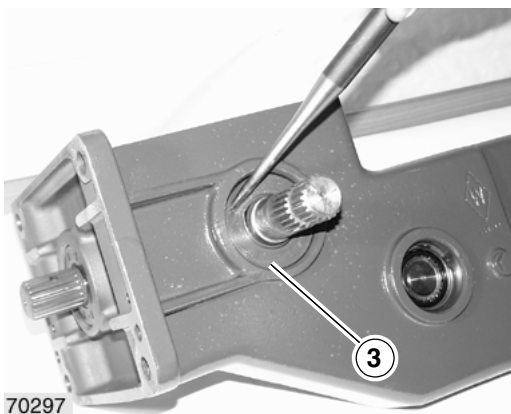

Remove the shaft seal rings (3) on the transmission case.

Note: Use a flat screw driver or similar tool. Do not push in too far to prevent damage to the bearings.

(Fig. 3)

70297

3

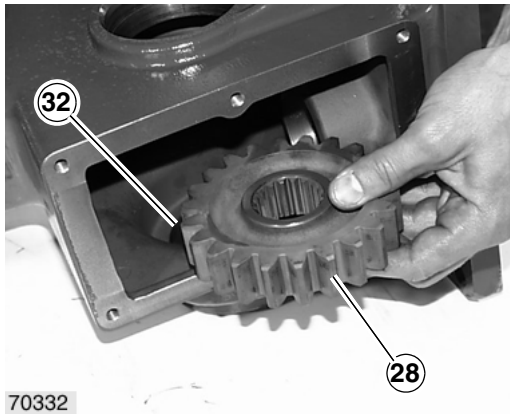

70332

38

Turn the transmission around and install the gears and shafts beginning with the drive shaft.

Lay the taper rolling bearing (32) of the drive shaft in the bearing rings.

Lay the entering spur gear (28) in the transmission case.

(Fig. 38)

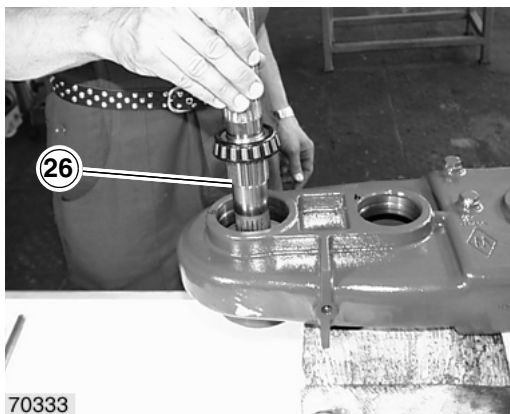

70333

39

Stick the drive shaft (26) through the hub of the entering spur gear in the transmission case and the taper rolling bearing.

(Fig. 39)

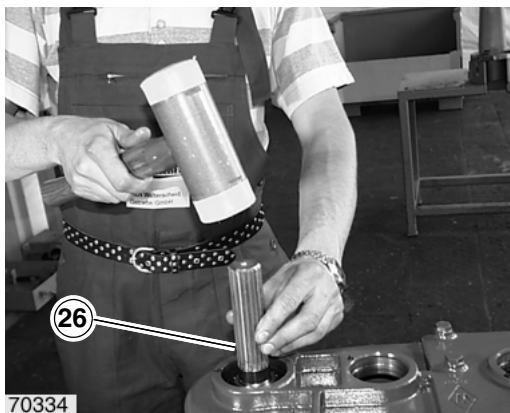

70334

40

Hammer the drive shaft (26) in the position of the taper rolling bearing with a rubber hammer.

(Fig. 40)

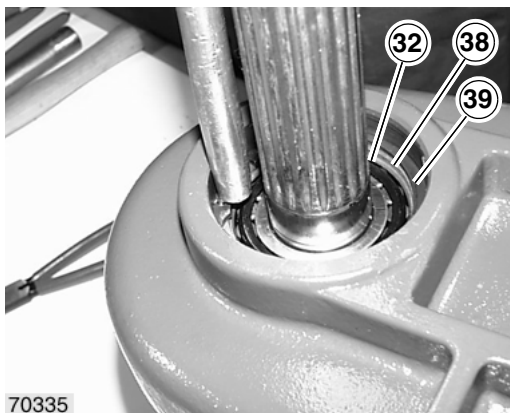

70335

41

Push on the bearing outer ring (32) in the bearing case with a brass punch.

Lay in the marked tight fitting washers (38).

Lay in the circlips (39) and push in with a punch.

Check that the circlip is completely in the groove.

(Fig. 41)

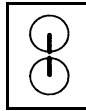
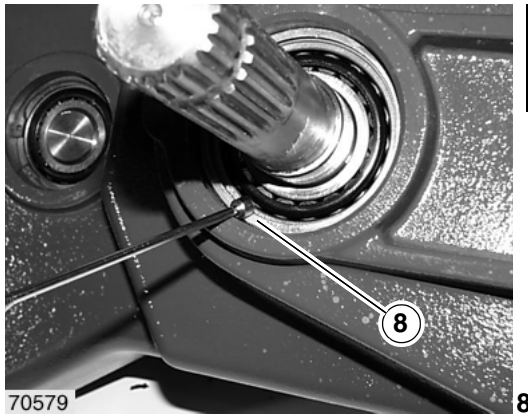

Take out the tight fitting washers (8) with the help of a magnet.

Mark the tight fitting washers and the circlip and keep for the re-assembly.

(Fig. 8)

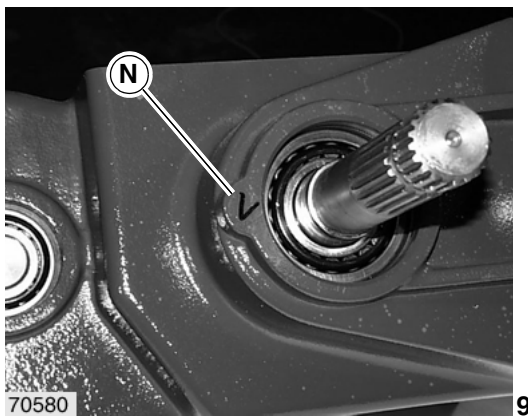

Mark the bearings which belong together on the transmission with the same number (N).

(Fig. 9)

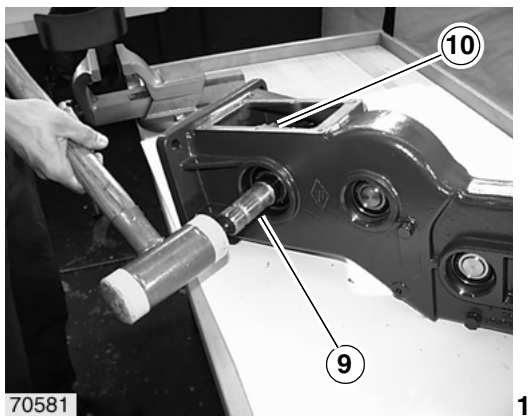

Hammer the drive shaft (9) from the left to right out of the transmission case with a rubber hammer. Pay attention that the beveled spur gear (10) does not tilt but comes off the shaft smoothly.

(Fig. 10)

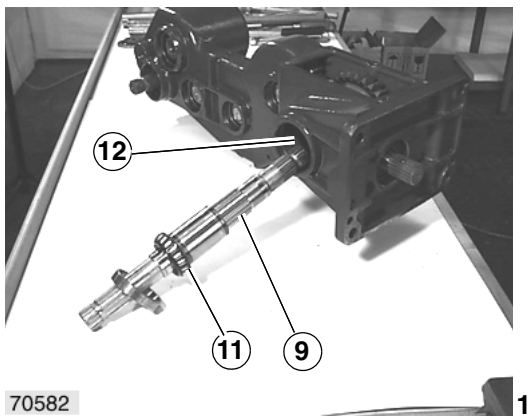

Take out the drive shaft (9) together with the taper rolling bearing (11).

Take off the spacer bushings (12) on the beveled spur gear.

(Fig. 11)

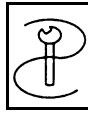

Pulling off the taper rolling bearing from the bevel gear shaft under a screw press using a special extractor.

(Fig. 47)

70321 47

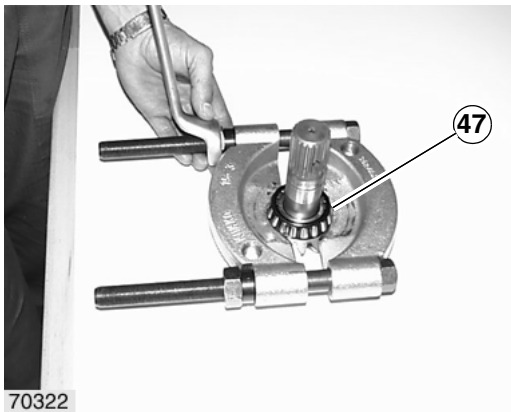

Grip the taper rolling bearing (47) in the special extractor.

(Fig. 48)

70322 48

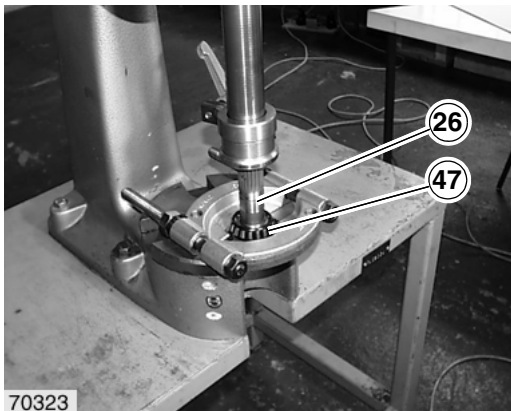

Squeeze the bevel gear shaft (26) out of the taper rolling bearing (47).

(Fig. 49)

70323 49

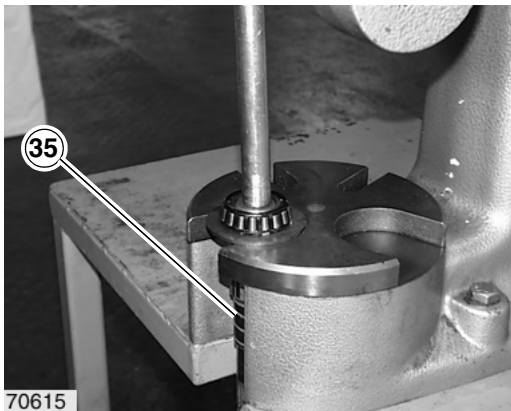

Squeeze off the taper rolling bearing from the drive shaft (35).

(Fig. 50)

70615 50

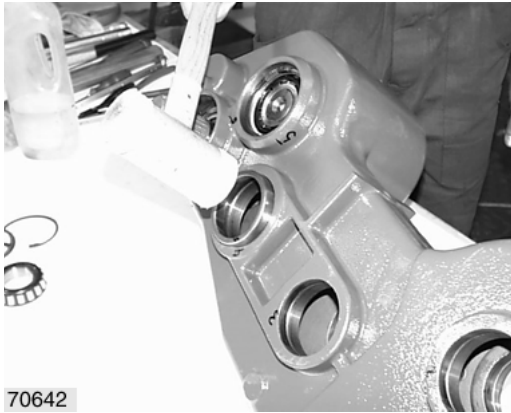

70642

82

On the right side, knock in all bearing rings of the intermediate shaft in the transmission case evenly with a plastic hammer and brass punch.

Note: Knock in the bearing ring approx. 2-3 mm over the groove for the circlip.

(Fig. 82)

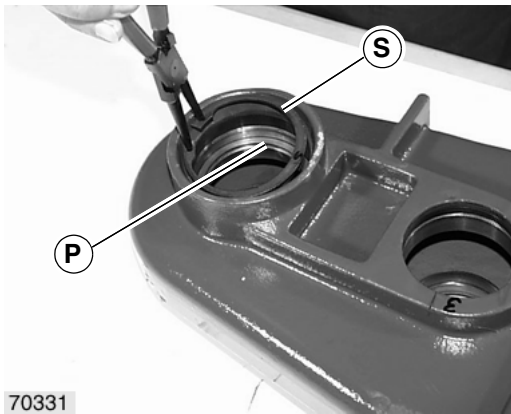

70331

83

Lay in the previously marked tight fitting washers (P) in their respective position.

Note: The thicker tight fitting washers always towards the circlip.

Pay attention when installing the circlip (S) that it is completely in the groove.

Counterblow the bearing rings so that they lay on the circlips.

(Fig. 83)

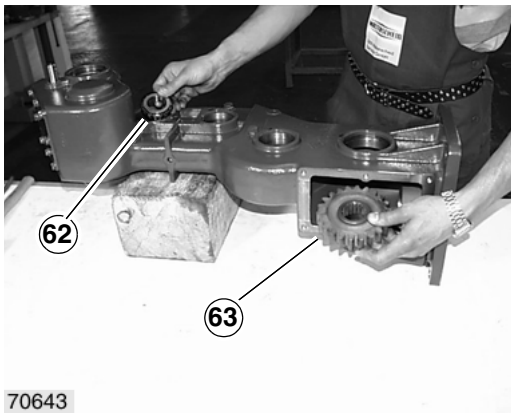

70643

84

Lay the transmission on the right side.

Lay the inner part of the taper rolling bearing (62) in the bearing ring.

Lay the entering spur gear (63) in the transmission case.

(Fig. 84)

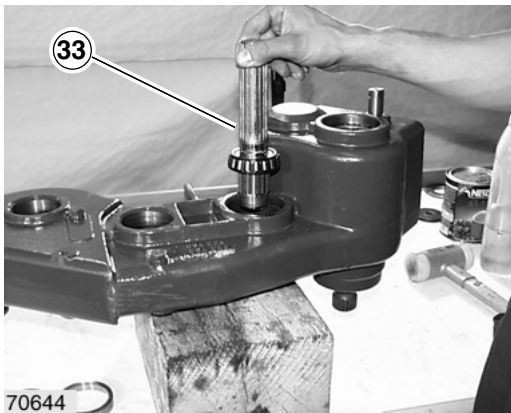

70644

85

Stick the drive shaft (33) through the hub of the entering spur gear in the transmission case and the taper rolling bearing.

(Fig. 85)

BEVEL TRANSMISSION

Taking apart/putting together the bevel transmission

Drain the transmission oil, and let drip!



Environment!

Dispose of oil and grease properly.

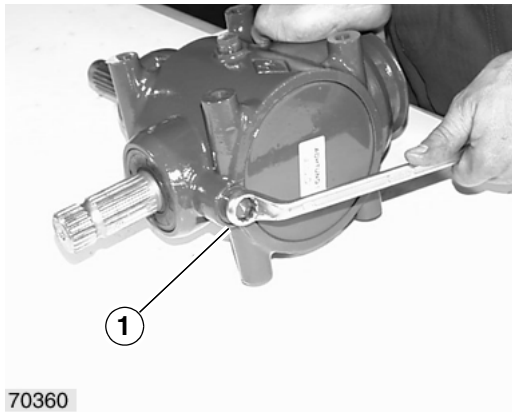

70360

1

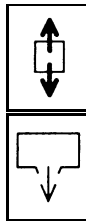

Unscrew and take out the screw plugs (1).

(Fig. 1)

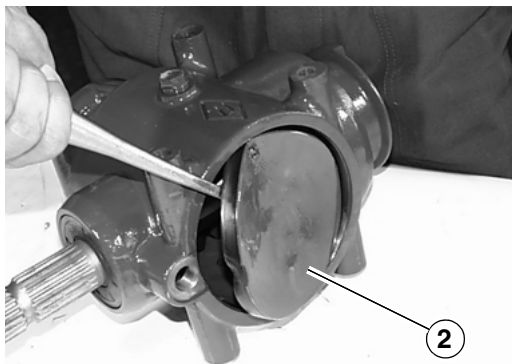

70361

2

Beat off the cap (2) with a few strokes of a hammer.

Pry the cap off the transmission case with a screw driver or similar tool.

(Fig. 2)

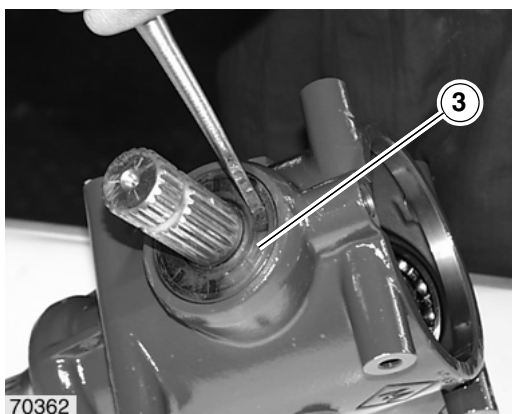

70362

3

Pry the shaft seal ring (3) off the transmission case with a screw driver or similar tool.

(Fig. 3)

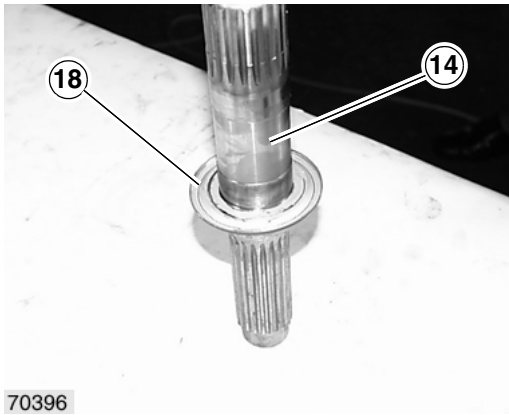

Put the circlip (18) on the drive shaft (14).
(Fig. 37)

70396

37

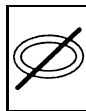
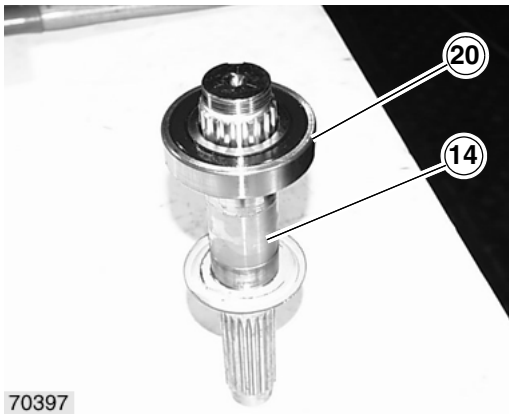

Stick the deep groove ball bearing (20) with sealed grease filling (2RS) on the drive shaft (14).
(Fig. 38)

70397

38

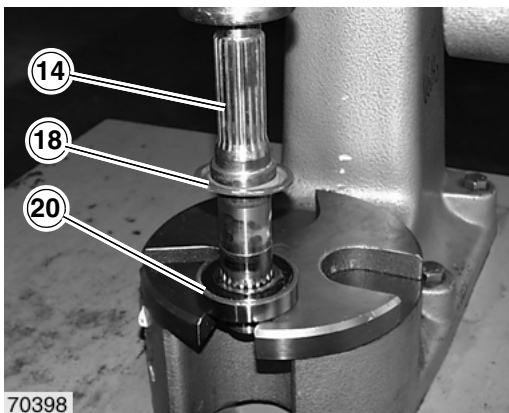

Press the deep groove ball bearing (20) on the drive shaft (14).

Note: The seal ring (18) must be firmly squeezed.
(Fig. 39)

70398

39

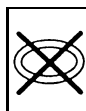
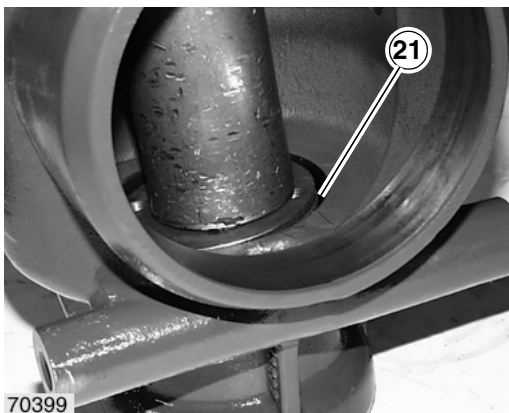

Knock in the shaft seal ring (21) in the transmission case with a suitable tool.

Suitable tool: Steel washers at least 8 mm thick, \varnothing 3 mm smaller than the outside diameter of the shaft seal ring.

(Fig. 40)

70399

40

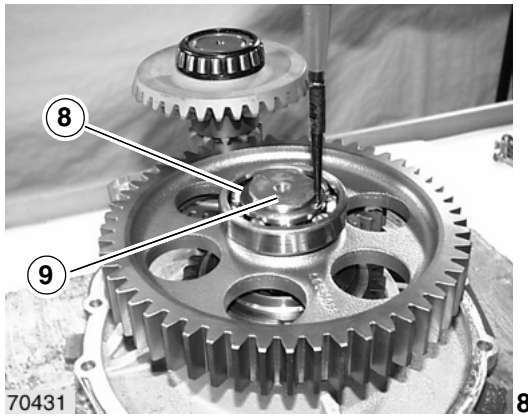

Take off the circlip (8) on the drive shaft (9).
(Fig. 8)

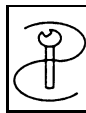
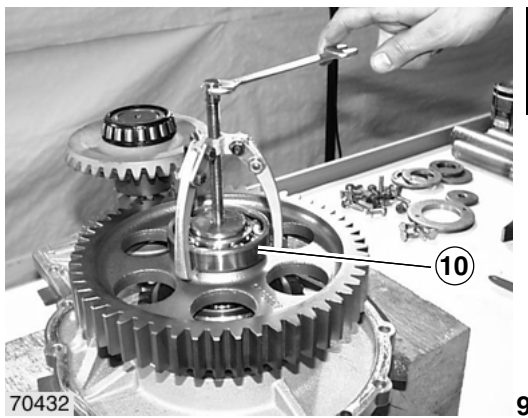

Pull off the deep groove ball bearing (10) from the drive shaft with an extractor.
(Fig. 9)

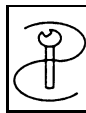

Take out the tight fitting washers (11) with the help of a magnet.
Mark the tight fitting washers together with the circlip (8) and keep for the re-assembly.
(Fig. 10)

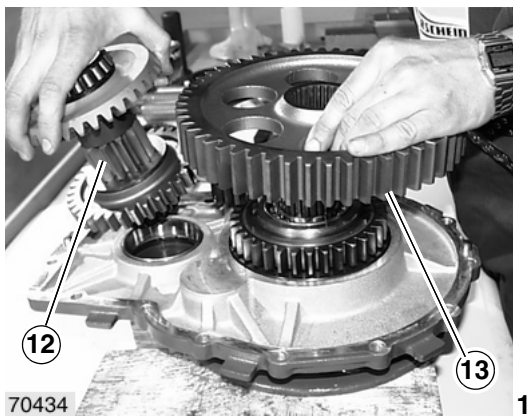

Lift out the spur gear shaft (12) together with the spur gear (13) of the drive shaft.
(Fig. 11)

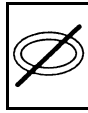
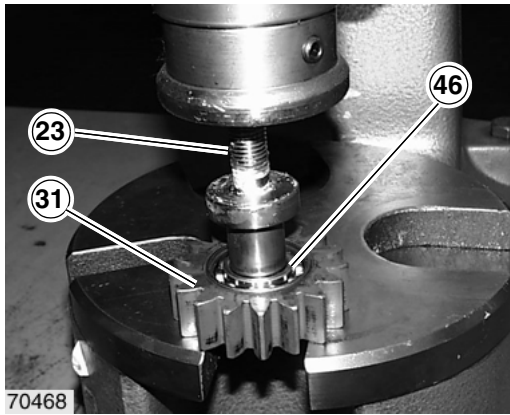

Pre-assemble the intermediate gear wheel axle:

1. Press the rear deep groove ball bearing (46) in the spur gear (31). Install a circlip between the bearings.
2. Press the intermediate gear wheel axle (23) in the rear deep groove ball bearing.

(Fig. 46)

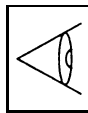
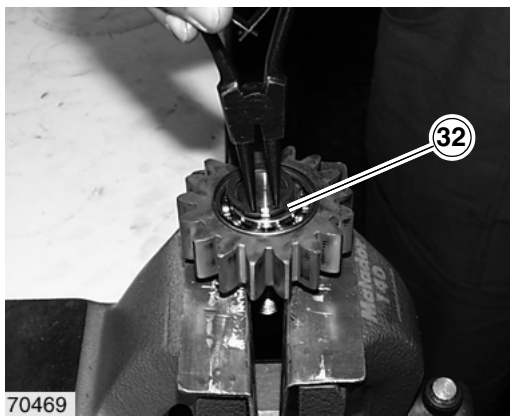

3. Assemble the circlip (32) on the intermediate gear wheel axle. Check that the circlip is completely in the groove.

(Fig. 47)

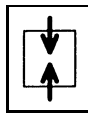
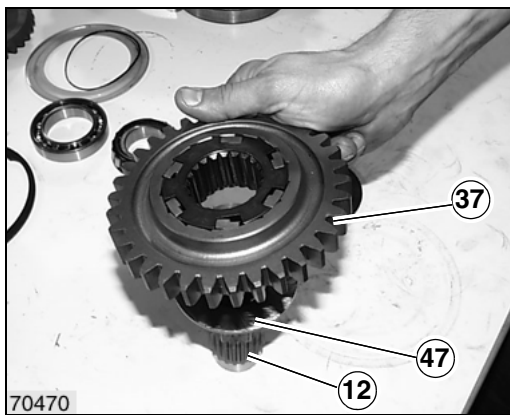

Assembling the free wheel hub:

1. Stick the washer (47) on the spur gear shaft (12).
2. Stick the pre-assembled spur gear with the free wheel hub (37) on the spur gear shaft.

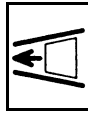

Note: Pay attention to the direction of rotation. The transmission is "counter-clockwise" in our assembly example. The position of the intermediate gear wheel axle can be used as a reference. If it sits on the right of the bevel gear shift, the transmission is counter-clockwise.

(Fig. 48)

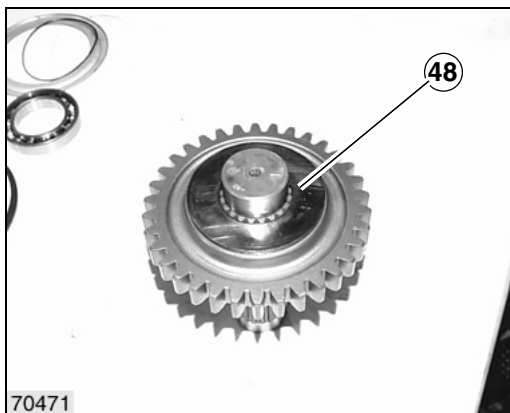

3. Lay on the upper washers (48).

(Fig. 49)

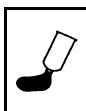
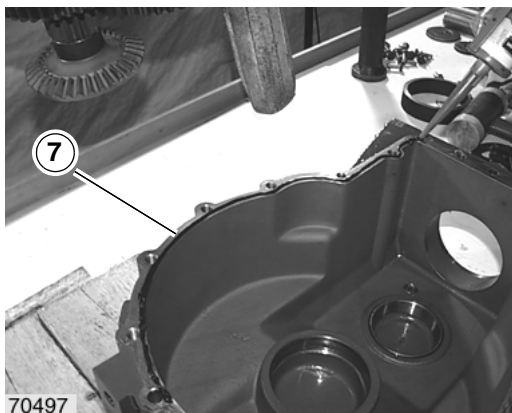

Grease the flange on the case and bearing housing.
Apply sealing compound, Atmosit for example, on the flange surface of the case (7).

Note: Apply sealing compound on the inside near the holes.
(Fig. 85)

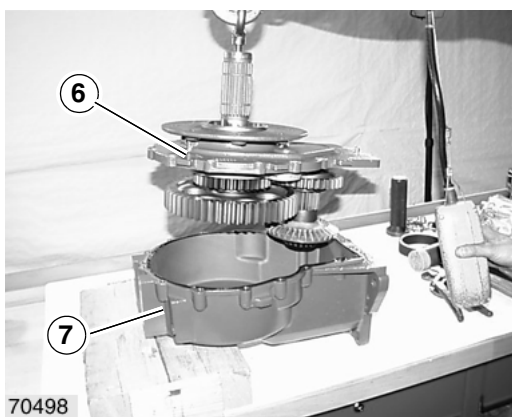

Install the completely assembled bearing housing (6) using a hoist into the case (7).

(Fig. 86)

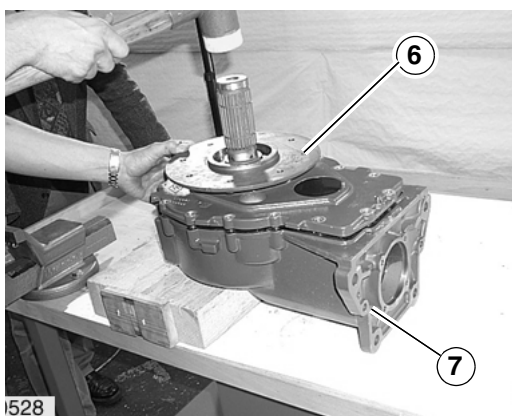

Fit the bearing housing (6) into the case (7) using a plastic hammer.

(Fig. 87)

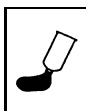
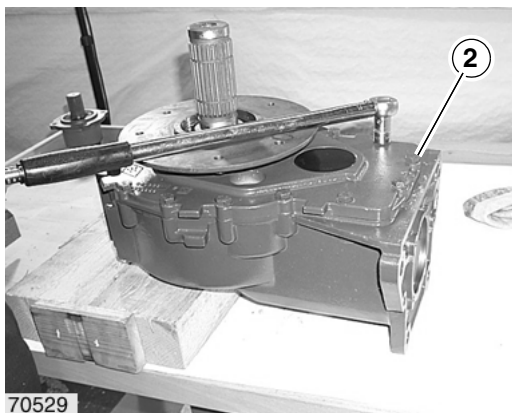

Twist in 14 hexagon head screws M10x40 ZA (2) with a few drops of ML 5249 (screw fastener) and contact washers B10.
Knock in the 3 dowel pins.

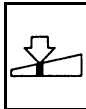

Tighten the hexagon head screws with a torque wrench. Torque setting is 50 Nm.
(Fig. 88)

ANGULAR TRANSMISSION

Taking apart the angular transmission

Drain the transmission oil, and let drip!

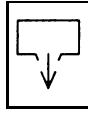

Environment!

Dispose of oil and grease properly.

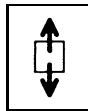
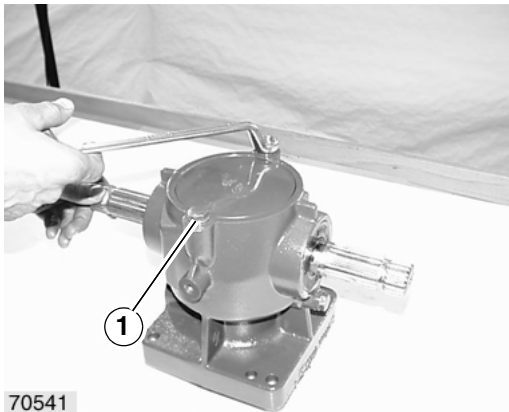

Unscrew the screw plugs (1).

(Fig. 1)

70541

1

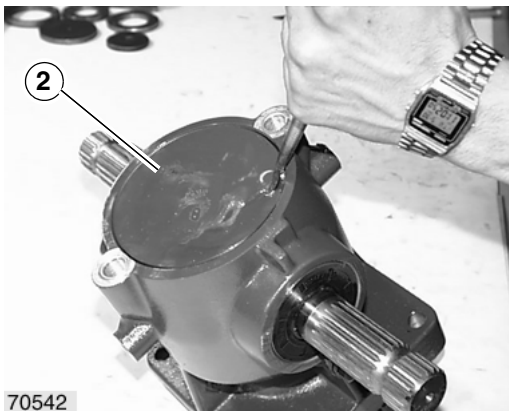

Beat off the cap (2) with a few strokes of a hammer.

Pry the cap off the transmission case with a screw driver or similar tool.

(Fig. 2)

70542

2

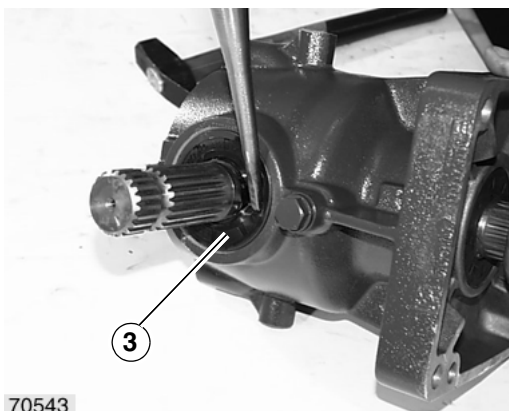

Pry the shaft seal ring (3) off the transmission case with a screw driver or similar tool.

Note: Use a flat screw driver or similar tool. Do not push in too far to prevent damage to the bearings.

(Fig. 3)

70543

3

CLICK HERE TO **DOWNLOAD** THE COMPLETE MANUAL

- Thank you very much for reading the preview of the manual.
- You can download the complete manual from: www.heydownloads.com by clicking the link below



- Please note: If there is no response to CLICKING the link, please download this PDF first and then click on it.

CLICK HERE TO **DOWNLOAD** THE COMPLETE MANUAL