

Mercedes-Benz OM502LA

CLAAS

Repair manual



Service & Parts

CLICK HERE TO **DOWNLOAD** THE COMPLETE MANUAL

- Thank you very much for reading the preview of the manual.
- You can download the complete manual from: www.heydownloads.com by clicking the link below



- Please note: If there is no response to CLICKING the link, please download this PDF first and then click on it.

CLICK HERE TO **DOWNLOAD** THE COMPLETE MANUAL

Gib head key joints

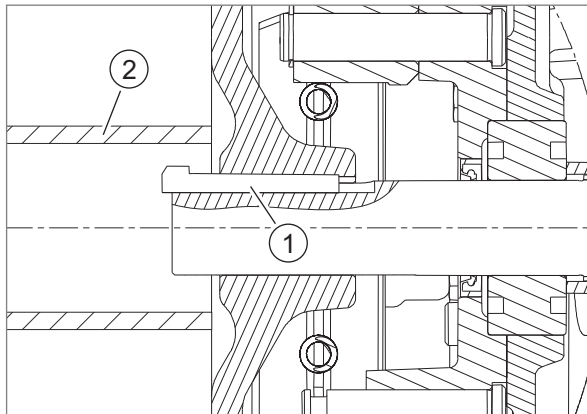

154811-001

7

Dismounting

- ▶ Slacken off gib head key (1) with a blow if possible.
 - ▶ Use an auxiliary tool (2) if required.

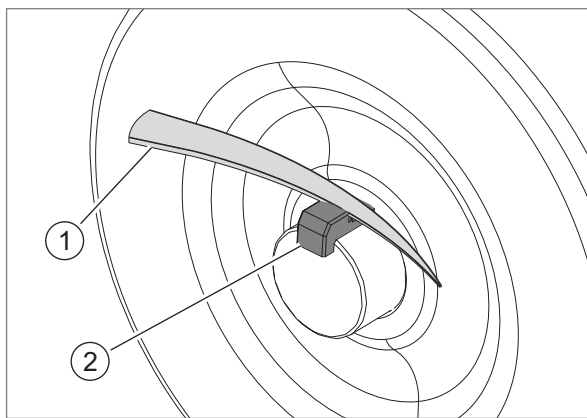

154813-001

8

- ▶ Drive out the gib head key (2) with a key drawer (1).
 - ▶ Ensure that the key drawer is used as shown in the figure.

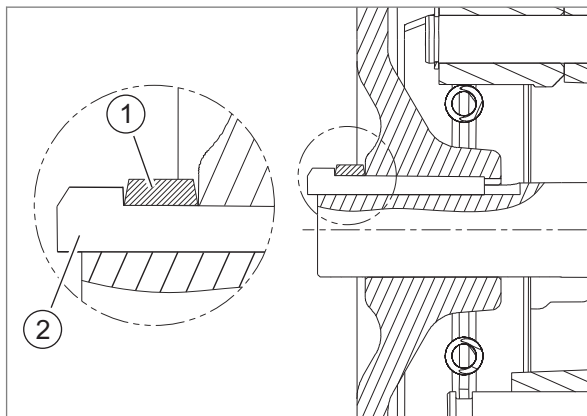

154812-001

9

Installation

The gib head key (1) comes in raw condition as a spare part and must be machined to suit the application by milling or grinding.

Tightening torques for metric fine thread screws

The tightening torques specified below apply only when:

- A friction coefficient of $\mu_{tot} = 0.14$ is achieved in connection with thread lubricant.
To achieve this, a surface protection agent such as A3C+L, Dacromet or Termosil is recommended.
- No other tightening torque is specified in the descriptive text.
- No additional screw retention is used, such as MK-type bolts or liquid locking compound.

Bolts and nuts		Tightening torque in Nm at a friction coefficient		
		$\mu_{tot} = 0.14$		
Strength class		8.8	10.9	12.9
Dimensions				
Hex. bolts ISO 8765, ISO 8876	M 8 x 1	26	38.5	45
	M 10 x 1	54	79	92.5
	M 10 x 1.25	51	74.5	88
	M 12 x 1.25	90.5	134	156
	M 12 x 1.5	87	128	150
	M 14 x 1.5	143	210	246
	M 16 x 1.5	219	323	378
	M 18 x 1.5	331	470	551
Hex. nuts ISO 4032	M 18 x 2	313	446	522
	M 20 x 1.5	459	655	766
	M 22 x 1.5	622	886	1037
	M 24 x 1.5	809	1152	1348
	M 24 x 2	778	1108	1297
	M 27 x 1.5	1173	1672	1956
	M 27 x 2	1135	1617	1892
	M 30 x 2	1580	2251	2634
M 33 x 2	2116	3015	3528	
M 36 x 2	2773	3951	4623	
M 39 x 2	3557	5067	5930	

Tightening torques for brake line screw fittings

Shape F union screws
Shape FS union screws with chime

Dimensions	Tightening torque in Nm
M10 x 1	14+2

123209-003

Tightening torques for worm drive hose clamps

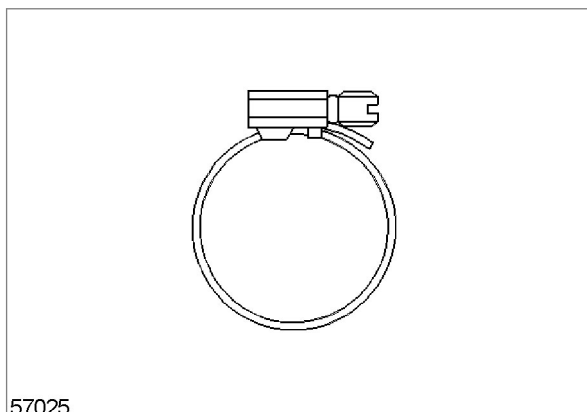

57025

30

8515-001

Width of clip	Tightening torques for new hoses when installing for the first time	Tightening torques for retightening or reassembling
7.9 mm (0.31 inch)	0.9 ± 0.2 Nm (8 ± 2 lb in)	0.7 ± 0.2 Nm (6 ± 2 lb in)
13.5 mm (0.53 inch)	4.5 ± 0.5 Nm (40 ± 4 lb in)	3.0 ± 0.5 Nm (27 ± 4 lb in)
15.9 mm (0.63 inch)	7.5 ± 0.5 Nm (65 ± 4 lb in)	4.5 ± 0.5 Nm (40 ± 4 lb in)

123211-002

Tightening torque for spring-loaded worm drive hose clamps

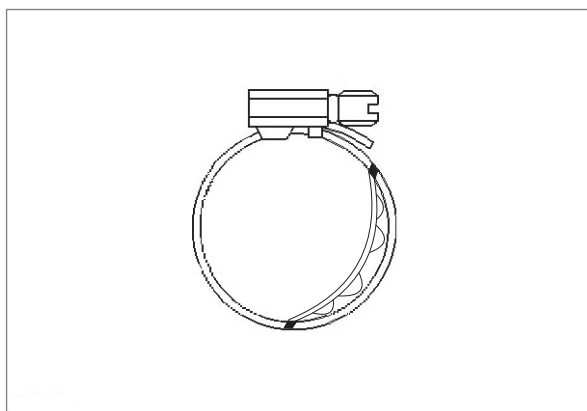

31

37503-001

Width of clip	Clamp diameter	Tightening torque
12 mm	60 - 80 mm	5 + 0.5 Nm
12 mm	70 - 90 mm	5 + 0.5 Nm

Electric welding

- ▶ Observe the welding information sheets.
- ▶ Disconnect the batteries.
- ▶ Fit earthing point of the welder close to the welding spot.
- ▶ Disconnect the control units.

Painting work

- ▶ During painting work, electronic components may be exposed to high temperatures (up to 95 °C) only for a short time.
- ▶ Disconnect the batteries.
- ▶ Remove sensitive electric components.
- ▶ Screw fittings of high-pressure lines must **not** be painted. Danger of introducing dirt in case of repairs.

Working with urea solution

124844-004

CAUTION

Contact with urea solution.

Danger of injury.

- ▶ Wash your skin thoroughly with water and soap. See a doctor if necessary.
- ▶ Flush eyes thoroughly with plenty of water. See a doctor if necessary.
- ▶ Flush mouth and drink plenty of water. See a doctor if necessary.















149012-002

NOTICE

Foreign substances pollute the system

Damage to exhaust gas system.

- ▶ Keep foreign substances and residual quantities of diesel fuel out of this system.
- ▶ Increased cleanliness requirements during installation work.

	Value	CCN	Remark / designation	
1		B16-MB	Camshaft position sensor	 Page 89  Page 94
2		B10-MB	Fuel temperature sensor	 Page 187
3		B111-MB	Charge air temperature and pressure sensor	 Page 279
4		B12-MB	Oil pressure sensor	 Page 219
5		B65-MB	Coolant temperature sensor	 Page 219
6		A6-MB (A015)	MR/PLD control unit	 Page 325
7		B15-MB	Crankshaft position sensor	 Page 94  Page 89
8		B14-MB	Oil level sensor	 Page 65
9		B129-MB (B360)	Urea pressure sensor	 Page 349
10		B130-MB	Urea temperature sensor	 Page 349
11		B128-MB	Dosing unit air pressure sensor	 Page 349
12		Y109-MB (Y487)	Urea dosing valve	 Page 349
Tightening torques not specified, see section on tightening torques				

0105 Engine suspension

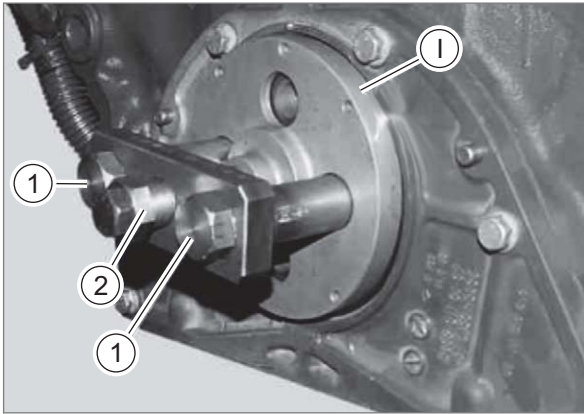

183303-001

- ▶ Bolt down special tool (I) with bolts (1).
 - ▶ Ensure that the special tool will not make contact with the radial seal, unscrew bolt (2) if required.
- ▶ Tighten bolt (2) until the special tool makes contact with the radial seal.

63

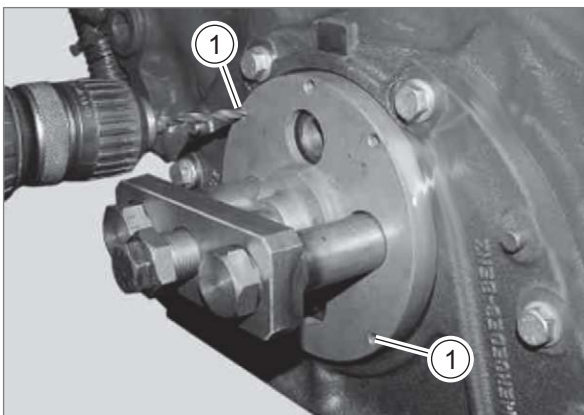

183304-001

- ▶ Drill two Ø3.5 mm holes into the radial seal through holes at (1).

64

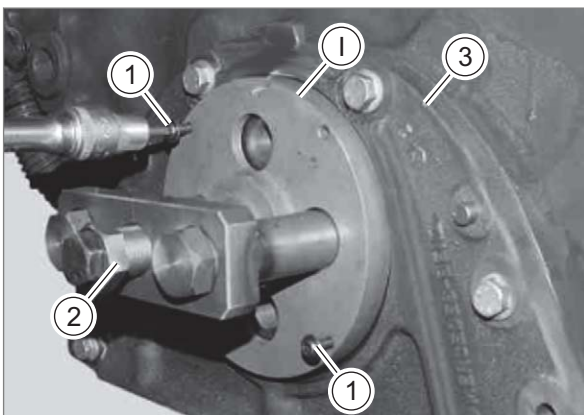

183305-001

- ▶ Tighten radial seal to special tool (I) with two bolts M4.8x25 (1).
- ▶ Unscrew bolt (2) until the radial seal has been pulled out of housing (3).
- ▶ Pull special tool (I) off of crankshaft flange together with the radial seal.
- ▶ Unscrew bolts (1).

65

- ▶ Check contact face of radial seal on the ring or on the crankshaft flange.
 - ▶ When run-in traces exist, replace the ring. 👁 [Page 138](#)

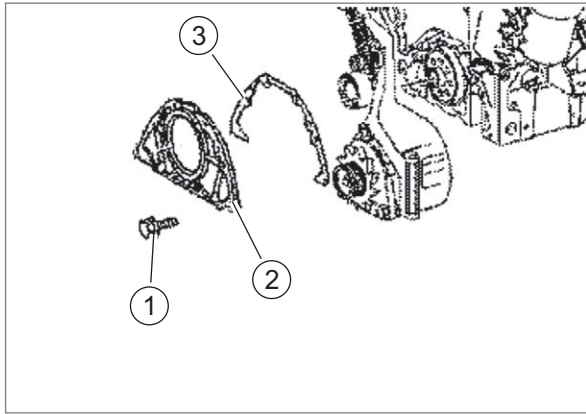

183751-001

- ▶ Unscrew bolts (1).
- ▶ Remove crankcase cover (2).
- ▶ Remove seal (3).
 - ▶ Clean the sealing face. [👁 Page 19](#)

83

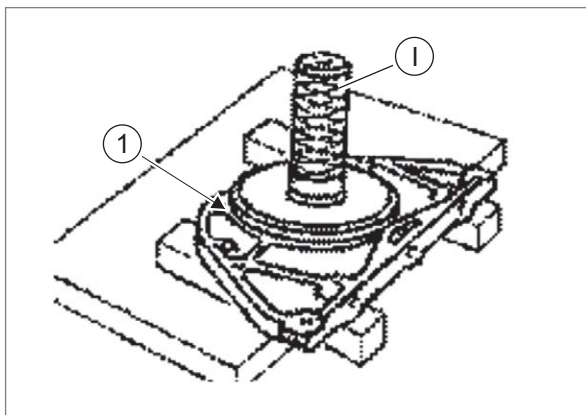

183752-001

- ▶ Remove radial seal (1) with special tool (I) if required.

84

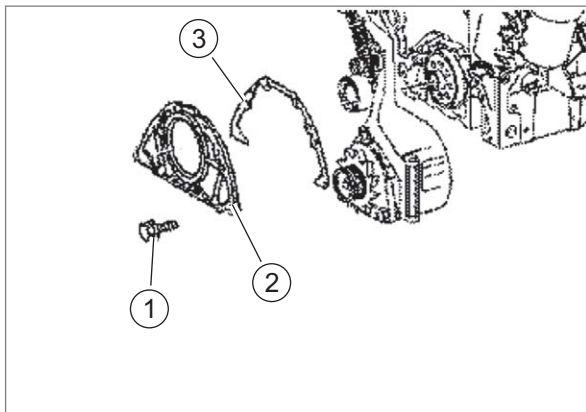

183751-001

Installation

- ▶ Fit new seal (3).
- ▶ Place crankcase cover (2) over the dowel pins on the crankcase and push it in.
- ▶ Screw in bolts (1).
Tightening torque: [👁 Page 80](#)

85

- ▶ Install the oil pan. [👁 Page 67](#)
- ▶ Installing the crankshaft front radial seal. [👁 Page 72](#)
- ▶ Install the oscillation damper. [👁 Page 143](#)

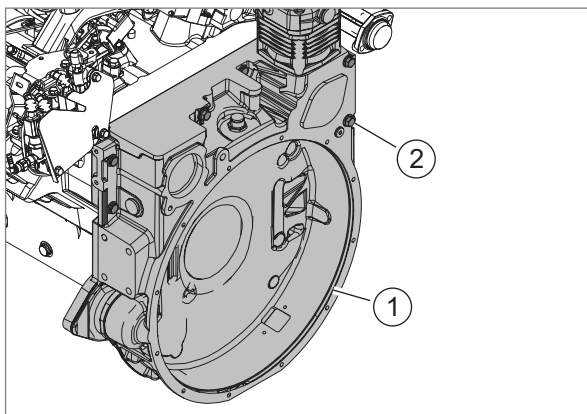

184405-001

102

- ▶ Ensure that all wiring looms and lines have been removed from the timing housing (1).
- ▶ Suspend the timing housing (1) in a suitable lifting equipment.
- ▶ Unscrew all bolts (2).
- ▶ Remove timing housing (1) carefully from the crankcase.

- ▶ Remove the crankshaft rear seal. [👁 Page 76](#)
- ▶ Remove compressor (1) if necessary.

Installation

- ▶ Clean all sealing faces. [👁 Page 19](#)
- ▶ Install compressor (1) if necessary. [👁 Page 306](#)
- ▶ Install a new crankshaft rear seal. [👁 Page 77](#)

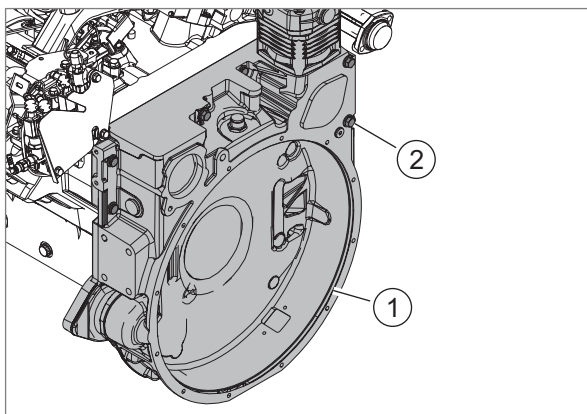

184405-001

103

- ▶ Suspend the timing housing in a suitable lifting equipment.
- ▶ Carefully position the timing housing with a new seal on the crankcase.
 - ▶ Coat seal with LOCTITE 510.
- ▶ Bolt down all bolts (2).
Tightening torque: [👁 Page 89](#)

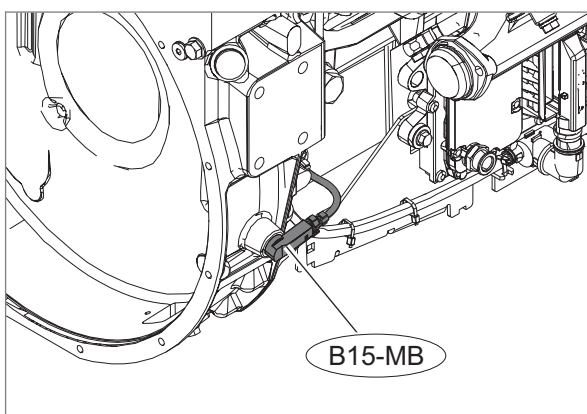

184404-001

104

- ▶ Install sensor (B15-MB).



39240-002

120

	Special tool (IV)	Pcs.
	Clock gauge 60 0500 530 3	1



147499-001

121

	Special tool (V)	Pcs.
	Measuring gauge holder 00 1992 870 0	1

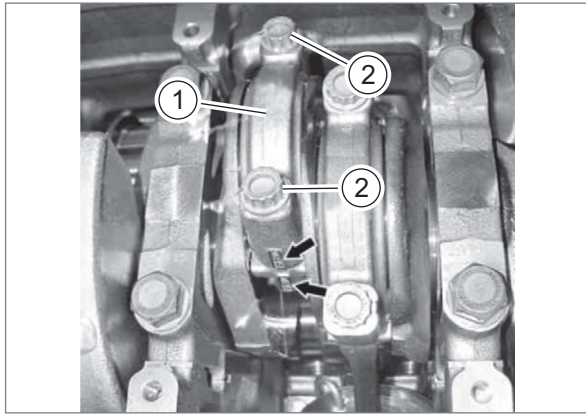

181563-001

139

- ▶ Position connecting rod bearing cover (1) together with the connecting rod bearing shell.
- ▶ Screw on the bolts (2).
Tightening torque: [Page 114](#)

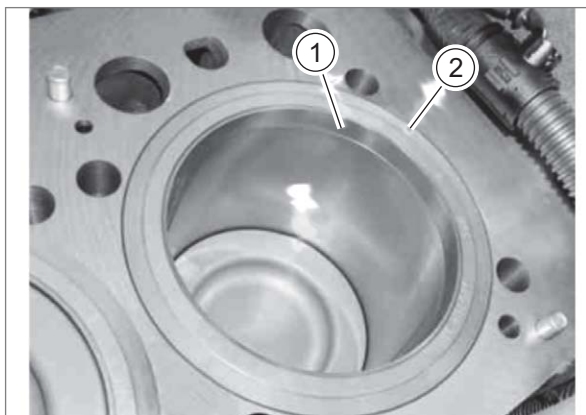

181564-001

140

- ▶ Insert scraper ring (1) into the cylinder liner (2).

- ▶ Measure the piston excess dimension. [Page 113](#)
- ▶ Install the cylinder head. [Page 161](#)
- ▶ Install the oil spray nozzles. [Page 216](#)
- ▶ Install the oil pan. [Page 67](#)

Installation

Applies to:

Type design: 942.991

Type design: 942.992

Type design: 458.990

Type design: 458.991

- ▶ Check cylinder liners. [Page 121](#)
- ▶ Check connecting rod bearing pin of the crankshaft. [Page 131](#)

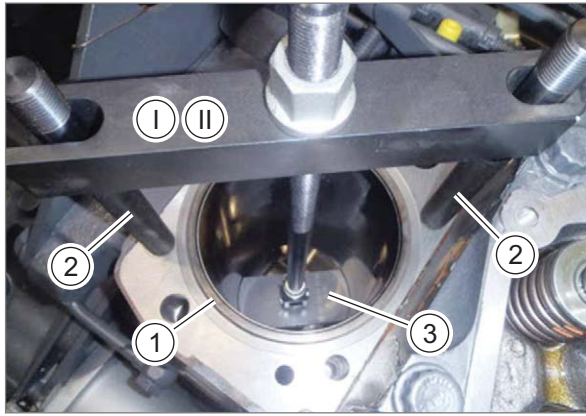

182755-001

156

Use special tools (I) and (II). [Page 117](#)

- ▶ Pull out cylinder liner (1).
 - ▶ Use threaded pin (2) of special tool (II).
 - ▶ Extraction device (3) of special tool (I) for type design:
 - ▶ 942.991; 942.992; 942.993
 - ▶ Extraction device (3) of special tool (II) for type design:
 - ▶ 458.990; 458.991; 458.992

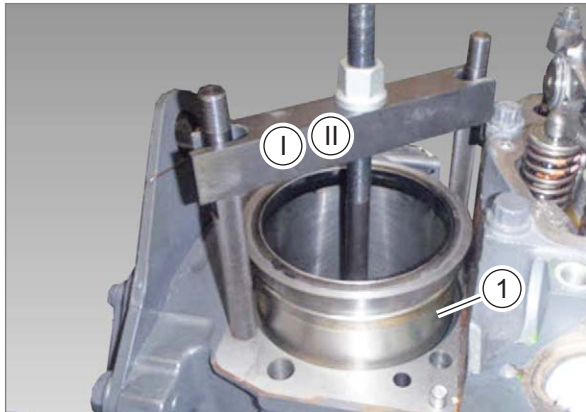

182758-001

157

- ▶ Remove upper sealing ring from the cylinder liner.
 - ▶ Measure and take down thickness of sealing ring.
- ▶ Remove lower sealing ring from the cylinder liner if required.
- ▶ Remove O-rings from the crankcase.
- ▶ Plug all openings tightly.

Checking

- ▶ Clean the cylinder liner thoroughly.
 - ▶ This is required only if the cylinder liner is re-used.
- ▶ Check the cylinder liner for cavitations and corrosion on the outside.
 - ▶ Replace the cylinder liner if required.

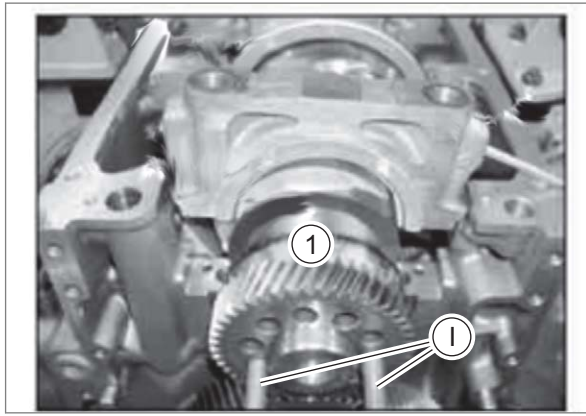

183035-001

172

- ▶ Screw in special tool (I) on both sides of crankshaft (1).
 - ▶ Lift out the crankshaft with a lifting device fitted to the special tools.
- Weight: [Page 127](#)

- ▶ Remove bearing shells from the crankcase.
 - ▶ Mark the bearing shells with respect to the crankcase.
- ▶ Clean the crankshaft.
- ▶ Clean the oil channel in the crankshaft and check if the passage is open.

Checking

- ▶ Check crankshaft for damage and cracks, replace the crankshaft if necessary.

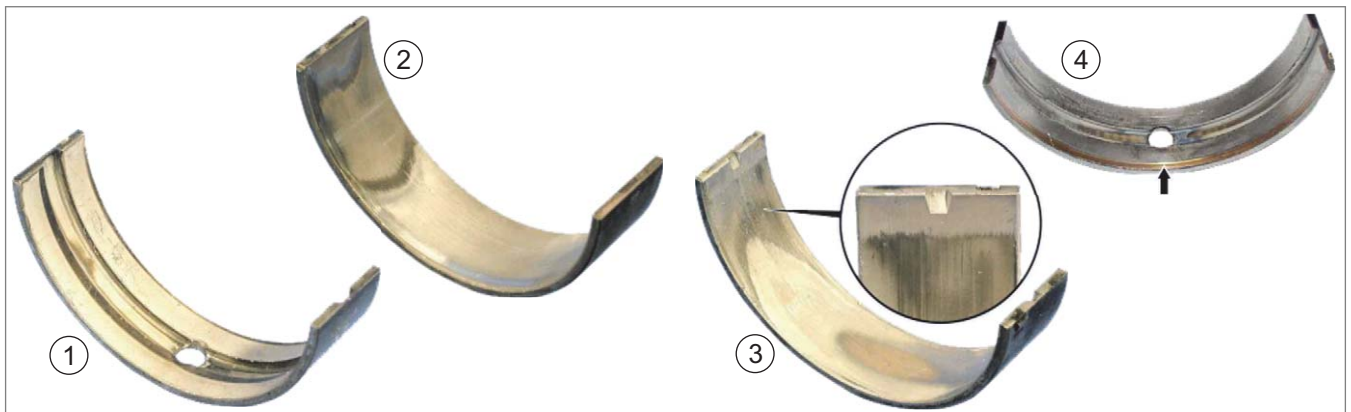

183067-001

173

- ▶ Checking the bearing shells:
 - 1 Bearing housing without damage.
 - ▶ The surface is even and smooth, without visible scores and without run-in wear.
 - ▶ *The bearing shell can be re-used.*
 - 2 Bearing shell with minor anti-friction layer wear.
 - ▶ Scores are hardly visible on the surface.
 - ▶ *The bearing shell can be re-used.*
 - 3 Bearing shell with large-surface anti-friction layer wear.
 - ▶ The run-in layer has been removed, the wear spot is clearly visibly.
 - ▶ *Replace all bearing shells.*
 - 4 Bearing shell with edge wear.

Oscillation damper



147453-001

191

Special tool

	Special tool (I)	Pcs.
1	Punch 00 1992 879 0	1



147565-001

192

	Special tool (II)	Pcs.
1	Socket 00 1992 952 0	1

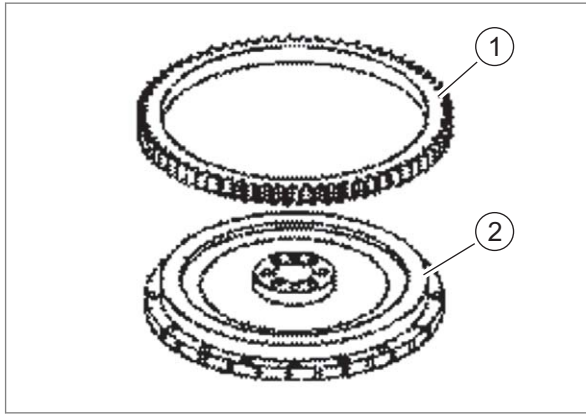

183482-001

211

- ▶ Heat up ring gear (1) to around 200 to 230 °C (light yellow temper colour) and force it on the flywheel (2) up to the stop.
 - ▶ Let the ring gear cool down for at least two minutes.
 - ▶ Readjust the ring gear with a brass punch.

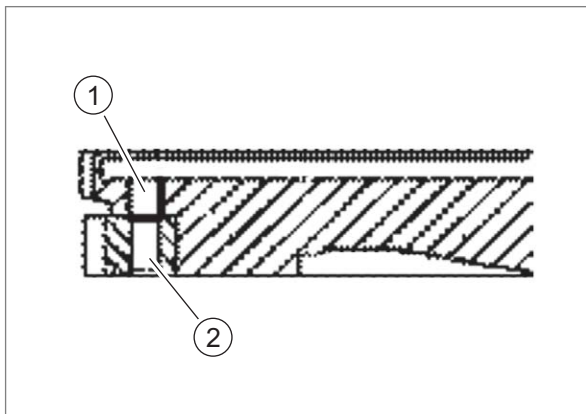

183483-001

212

- ▶ Following bores (1) in the flywheel, drill tapped holes M10x1.5 (2) into the ring gear.

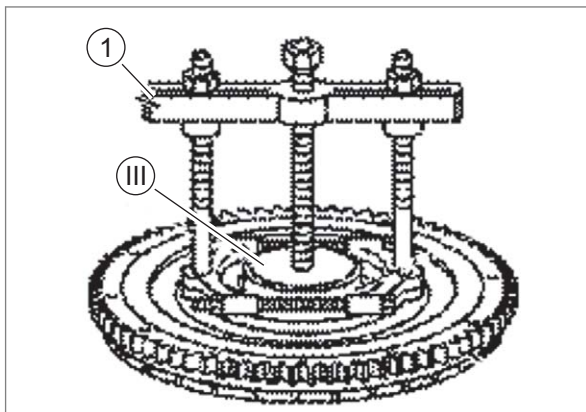

183499-001

213

- ▶ Install flywheel. [👁 Page 149](#)

Replacing the ring

- ▶ Remove the flywheel. [👁 Page 148](#)
- ▶ Remove the crankshaft rear seal. [👁 Page 76](#)

Use special tool (III). [👁 Page 145](#)

- ▶ Pull off ring with a puller (1).

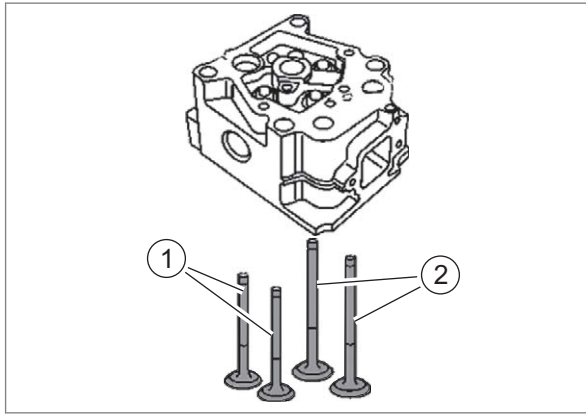

180343-001

227

- ▶ Mark and remove intake valves (1) and exhaust valves (2).

- ▶ Check valve guides and replace them if required. [👁 Page 178](#)
- ▶ Check the valve seat inserts.
If the inserts are heavily worn, the cylinder head must be replaced.
- ▶ Check the valves. [👁 Page 168](#)

Assembly

- ▶ Check the cylinder head. [👁 Page 159](#)
 - ▶ Check valve guides and replace them if required. [👁 Page 178](#)
 - ▶ Check the valve seat inserts.
If the inserts are heavily worn, the cylinder head must be replaced.
 - ▶ Check the valves. [👁 Page 168](#)
-
- ▶ Install intake valves (1) and exhaust valves (2) as marked.
Observe the technical information in the "Valves" chapter! [👁 Page 167](#)

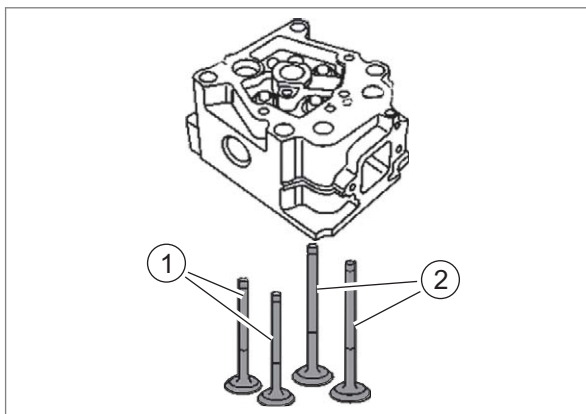

180343-001

228

- ▶ Install valve springs and valve stem seals. [👁 Page 174](#)
- ▶ Install the nozzle holder combination. [👁 Page 197](#)

Installation

- ▶ Check the shaft length (a) of the cylinder head bolts. [👁 Page 156](#)

Valve springs and valve stem seals



147544-001

238

Special tool

	Special tool (I)	Pcs.
1	Installation tool 00 1992 951 0	1



32852-001

239

	Special tool (II)	Pcs.
1	Magnetic rod 00 0181 842 0	1



236739-001

240

	Special tool (III)	Pcs.
1	Installation device 00 1993 213 0	1

Camshaft

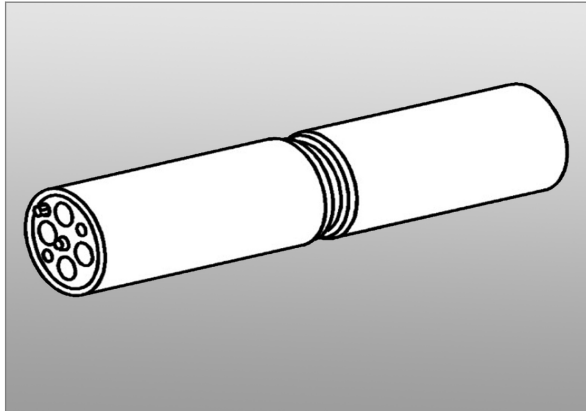

237673-001

257

Special tool

	Special tool (I)	Pcs.
1	Guide bushing 00 1995 520 0	1



39240-002

258

	Special tool (II)	Pcs.
1	Clock gauge 60 0500 530 3	1



183116-001

259

	Special tool (III)	Pcs.
1	Measuring gauge holder 60 0500 530 5	1

CLICK HERE TO **DOWNLOAD** THE COMPLETE MANUAL

- Thank you very much for reading the preview of the manual.
- You can download the complete manual from: www.heydownloads.com by clicking the link below





- Please note: If there is no response to CLICKING the link, please download this PDF first and then click on it.

CLICK HERE TO **DOWNLOAD** THE COMPLETE MANUAL

- See the Operator's Manual of the machine in question.
- Let the diesel engine run at different speeds.
- Carry out a visual tightness inspection of injection line screw fittings.
 - Replace injection line if necessary.

Installing:

- Install a new O-ring.
- Insert protective sleeve.
- Screw on protective sleeve with special tool (I).
- Install the nozzle holder combination.  [Page 197](#)
- Top up coolant.  [Page 232](#)

Applies to type designs:

906.991

926.9xx

Fuel filter housing

Technical specifications

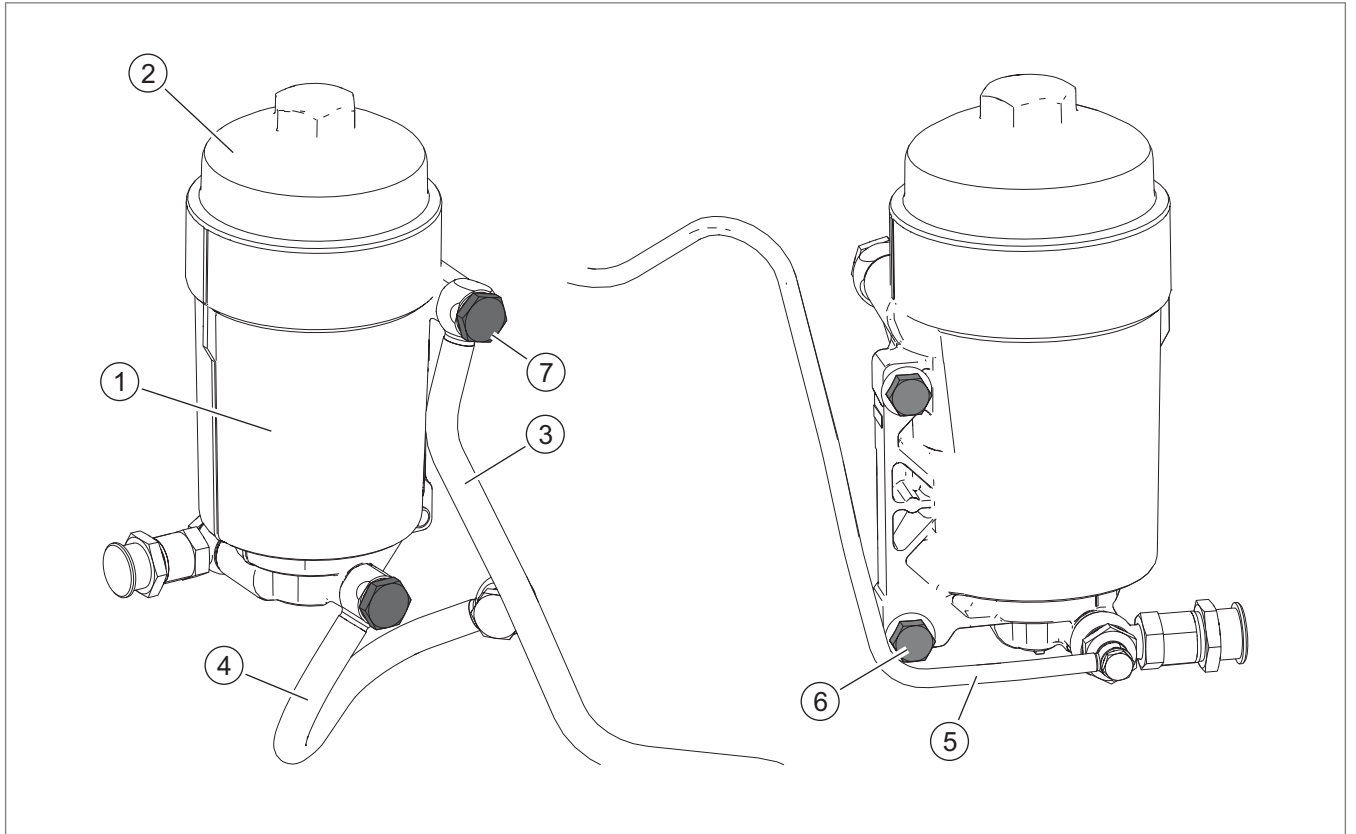

186025-001

301

	Value	CCN	Remark / designation
1	1.5 kg		Fuel filter housing
2	25 Nm		Cover
3			Feed fuel line
4			Return fuel line
5			Fuel leakage line
6	50 Nm		Fuel filter housing mounting bolts
7	50 Nm		Fuel lines hollow screws
Tightening torques not specified, see section on tightening torques			

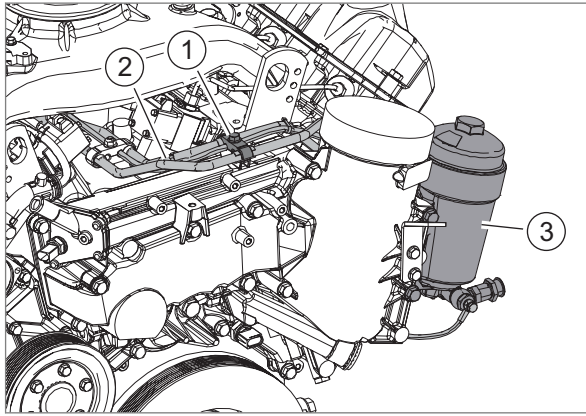

185789-001

314

- ▶ Remove brackets (1) of fuel lines (2).
- ▶ Unscrew fuel filter (3).
 - ▶ Do **not** unscrew the fuel lines from the fuel filter!

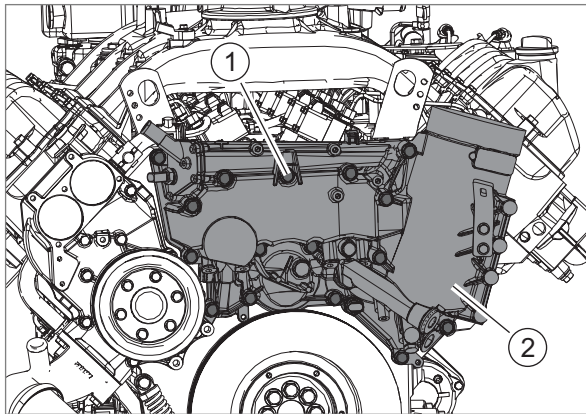

185790-001

315

- ▶ Unscrew all bolts (1) and remove the oil filter housing (2).
- ▶ Remove seal.
- ▶ Clean the sealing faces. 👁 [Page 19](#)

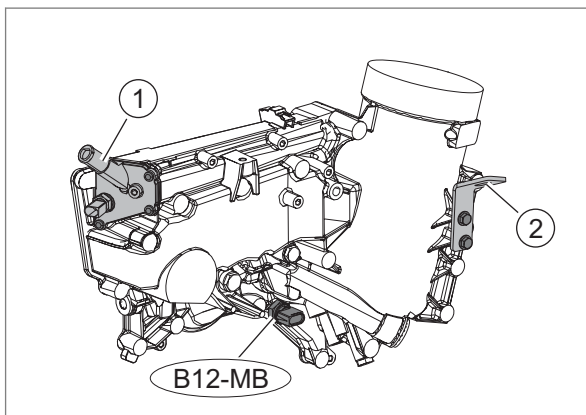

185791-001

316

- ▶ Unscrew the coolant union (1).
- ▶ Unscrew bracket (2).
- ▶ Unscrew sensor (B12-MB).
- ▶ Remove the oil cooler. 👁 [Page 225](#)

Technical specifications

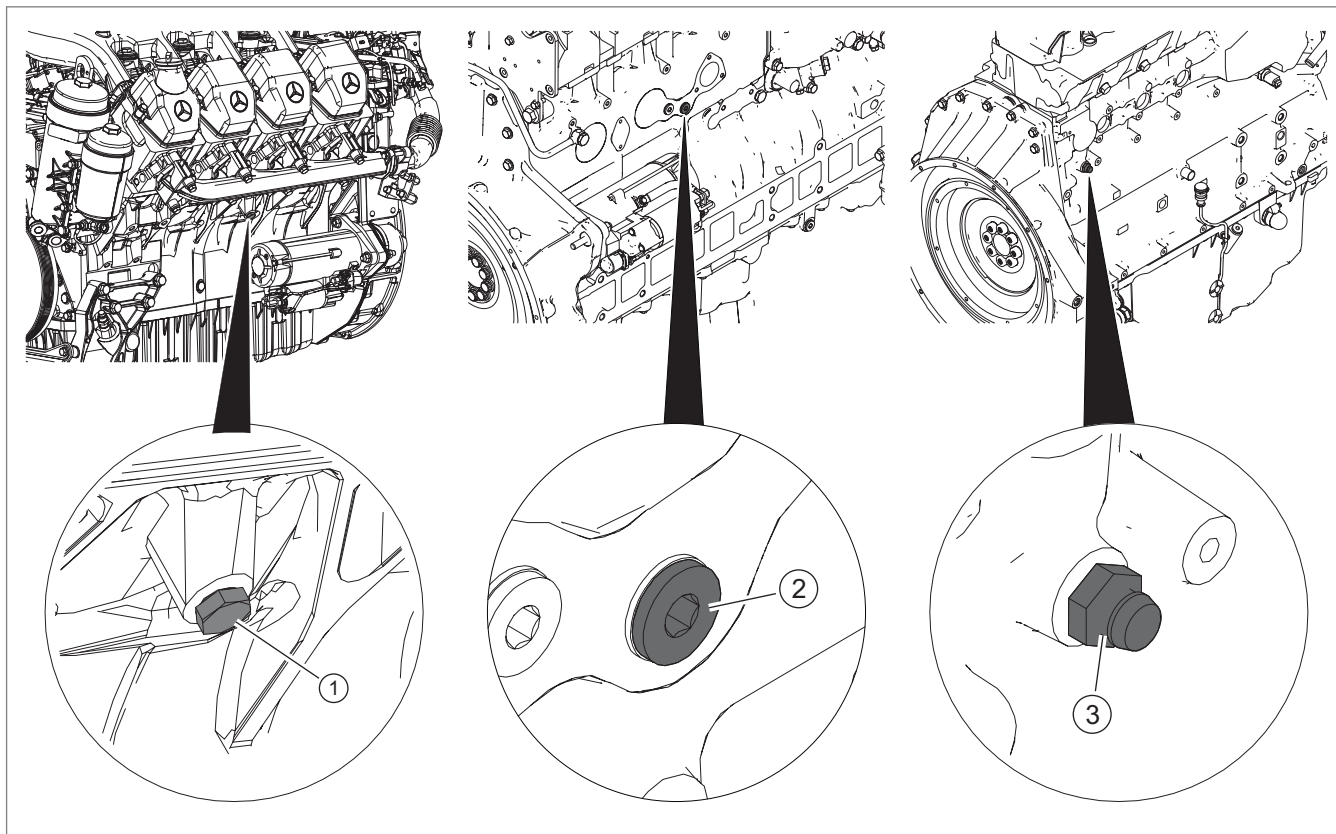

179772-001

327

	Value	CCN	Remark / designation
1	50 Nm		Coolant drain plugs Type design: 942.99x – Plugs on both sides of the engine. – Screw in bolts with a new sealing ring.
2	50 Nm		Coolant drain plug Type design: 458.99x – Insert bolt with a new sealing ring.
3	60 Nm		Coolant drain plug Type design: 906.99x and 926.9xx – Insert bolt with a new sealing ring.
Tightening torques not specified, see section on tightening torques			

Draining

- ▶ Drain the coolant from the machine radiator.
See the Operator's Manual of the machine in question.

157892-002

WARNING! Drain the coolant from the engine block.
Danger of skin and eye injury from hot coolant.
Danger of poisoning when swallowed.

Coolant thermostat**Work preparation**

Utilities:

- ▶ Lubricants:
CLAAS AGRIGREASE EP 2 - 00 0147 437 0
-

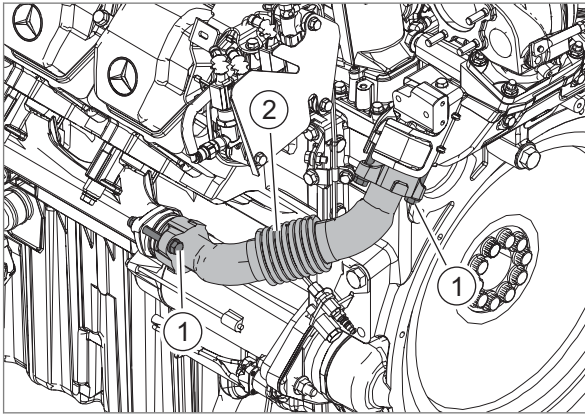

185068-001

359

- ▶ Fit flexible exhaust pipe (2).
- ▶ Screw in bolts (1) hand-tight.

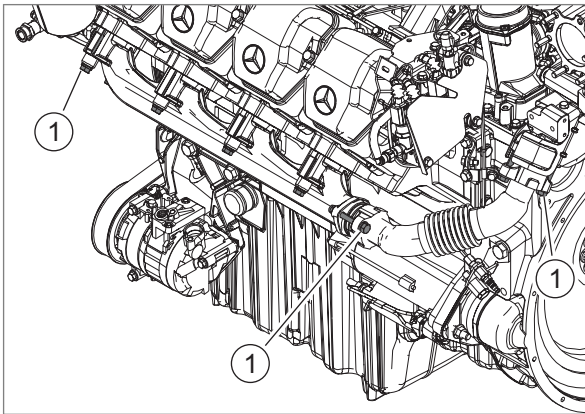

185069-001

360

- ▶ Tighten all bolts (1) so that the exhaust manifolds will not be subject to strain.
Tightening torque: 👁 [Page 248](#)

Exhaust turbo charger

Applies to:

Type design with one exhaust turbo charger

Special tool



39240-002

373

	Special tool (I)	Pcs.
1	Clock gauge 60 0500 530 3	1



147530-001

374

	Special tool (II)	Pcs.
1	Extension 00 1992 875 0	1



183116-001

375

	Special tool (III)	Pcs.
1	Clock gauge 60 0500 530 5	1

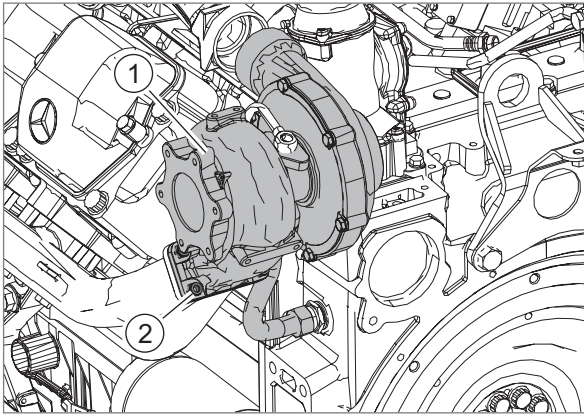

184622-001

395

- ▶ Unscrew nut (2).
- ▶ Carefully remove the exhaust turbo charger (1).

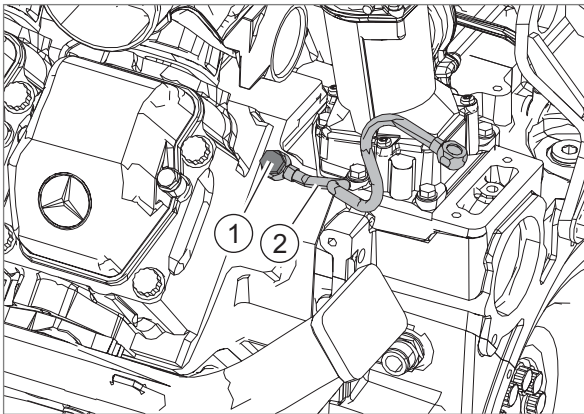

184623-001

396

- ▶ Unscrew hollow screw (1) and remove oil feed line (2).

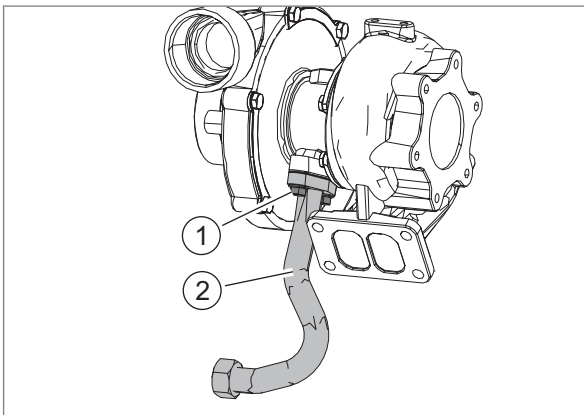

184624-001

397

- ▶ Unscrew bolts (1) and remove oil return line (2).

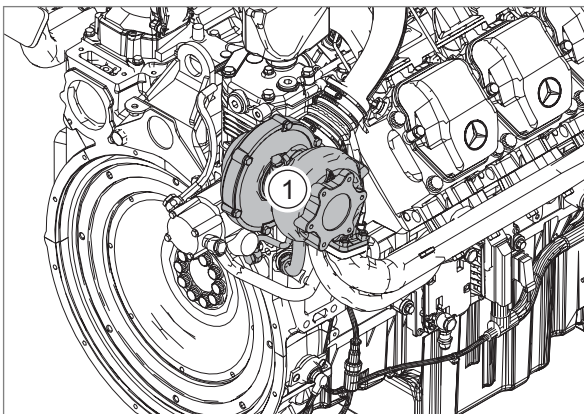

184625-001

398

- ▶ Repeat these steps for the right-side turbocharger (1) on the other side of the engine.

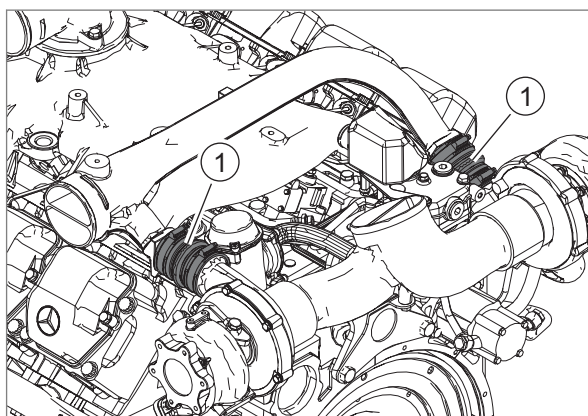

179809-001

Applies to type designs with two exhaust turbochargers

- ▶ Unscrew charge air hoses (1).

411

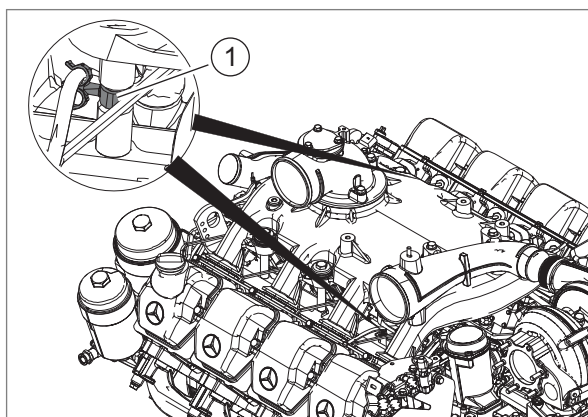

179810-001

- ▶ Ensure that all retaining clips (1) are slackened off of the mounting bolts.

412

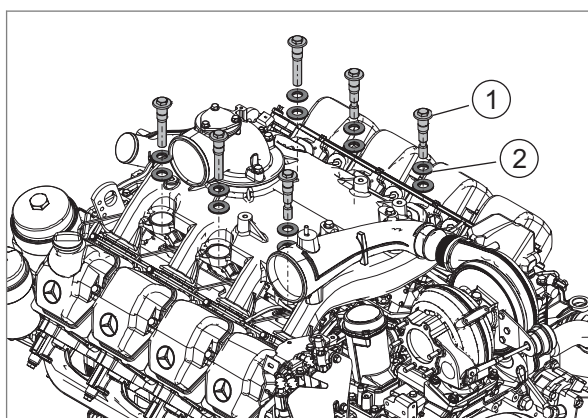

179811-001

- ▶ Unscrew the mounting bolts (1).
 - ▶ If necessary, mark the installation position of the retaining clip bolts.
- ▶ Remove belleville springs (2).

413

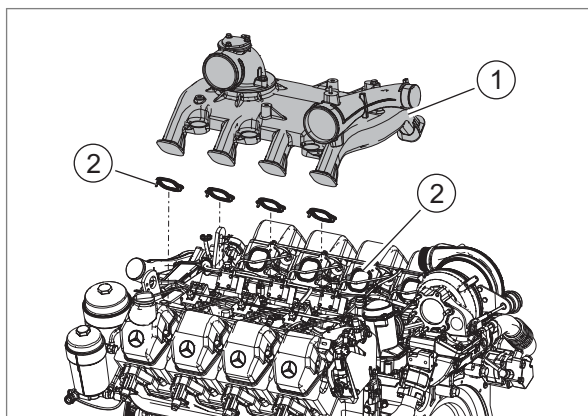

179812-001

- ▶ Carefully remove intake housing (2).
- ▶ Remove seals (2).

414

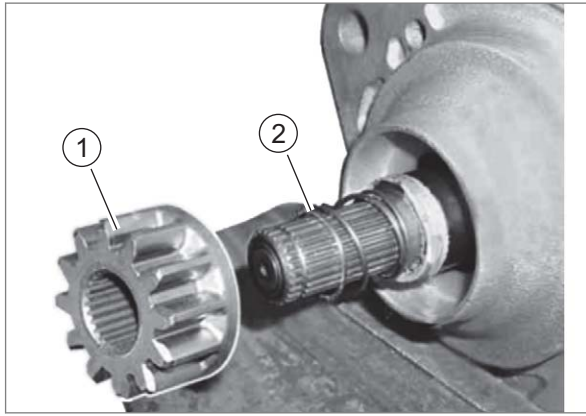

185361-001

436

- ▶ Remove starter pinion (1).
- ▶ Remove spring (2).

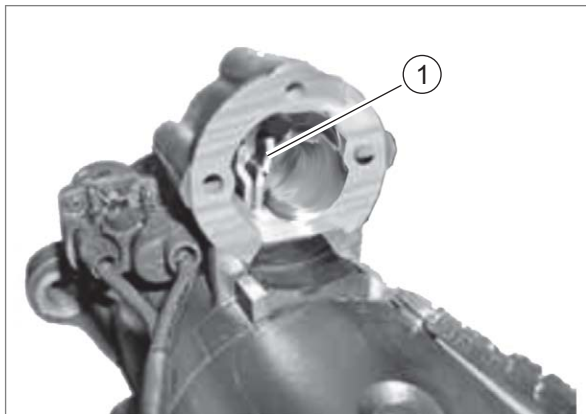

185359-001

437

Installing the starter pinion

- ▶ Pull back and hold the release fork (1).

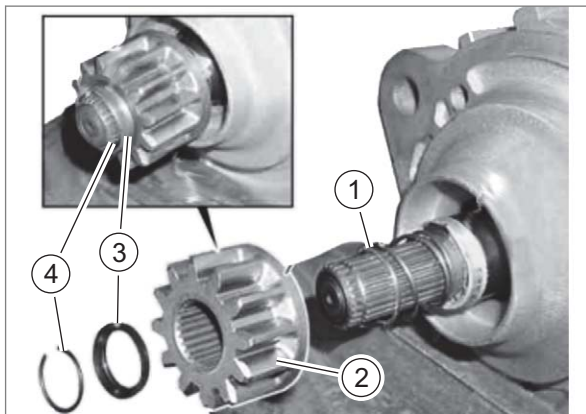

185362-001

438

- ▶ Slide on spring (1).
- ▶ Slide on starter pinion (2).
Slightly grease starter pinion and shaft.
- ▶ Slide on stop ring (3).
- ▶ Fit circlip (4).

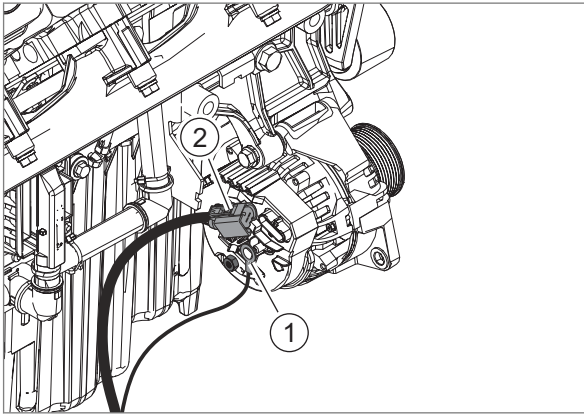

185534-001

Alternator (G003)

- ▶ Disconnect cable (1).
- ▶ Disconnect connector (2).

456

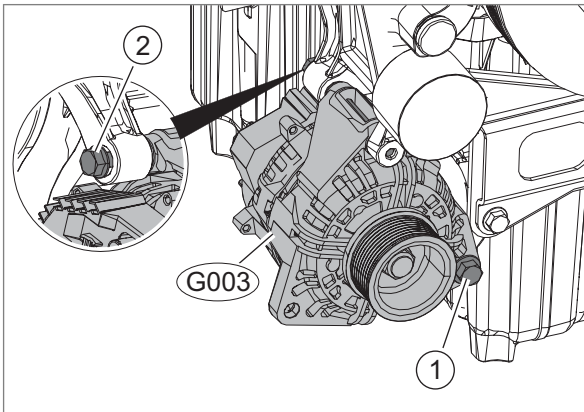

185535-001

Alternator (G003)

- ▶ Unscrew bolt (1).
- ▶ Unscrew bolt (2) and remove alternator (G003).

457

Installation

Alternator (G002)

- ▶ Insert alternator (G002) and bolt down with bolt (2).
- ▶ Screw on the bolt (1).
Tightening torques:  [Page 299](#)

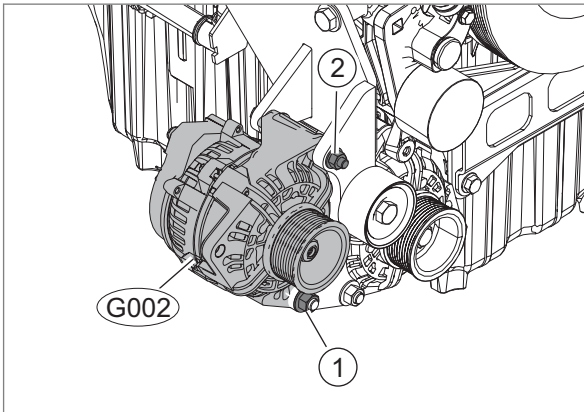

185532-001

458

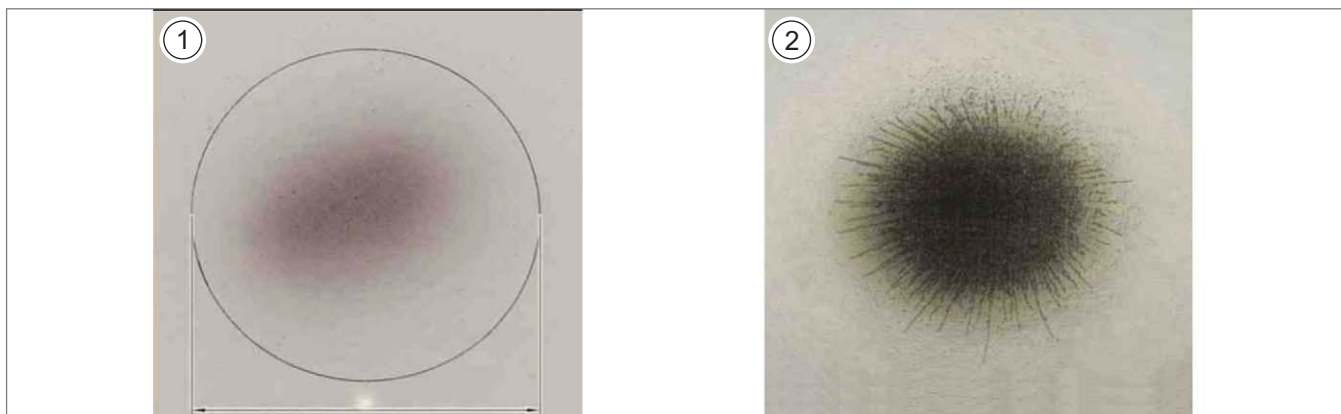

184837-001

475

	Oil thrown out	Resulting pattern
1	Normal amount of oil thrown out	The resulting pattern is black, but feels dry.
2	Too much oil thrown out	The resulting pattern is black, but feels wet.

When detecting an excessive amount of oil being thrown out, the test sheet must be delivered along with the defective part in cases of warranty or goodwill. Otherwise, the matter cannot be dealt with as a case of warranty or goodwill.

- ▶ After checking the resonance vessel, reinstall the compressed air line.

Removing the drive wheel

- ▶ Remove the engine.
See the repair manual of the machine in question.
- ▶ Block the engine so it will not rotate.
 - ▶ Install the special tool from the "Cranking the engine" chapter. [👁 Page 53](#)
- ▶ Remove the timing housing cover. [👁 Page 83](#)

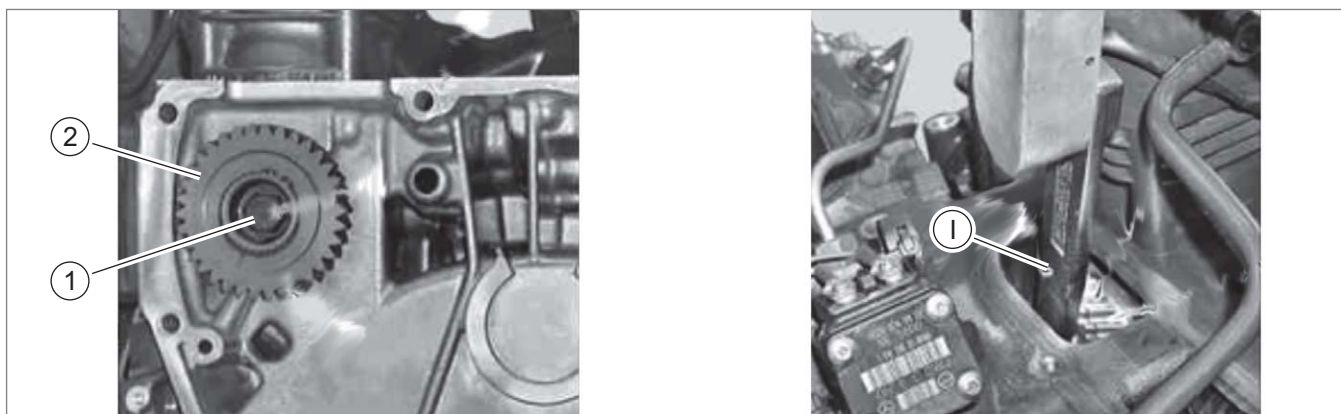

184754-001

476

- ▶ Slacken off nut (1) of drive wheel (2), using special tool (I).
- ▶ Remove the timing housing.

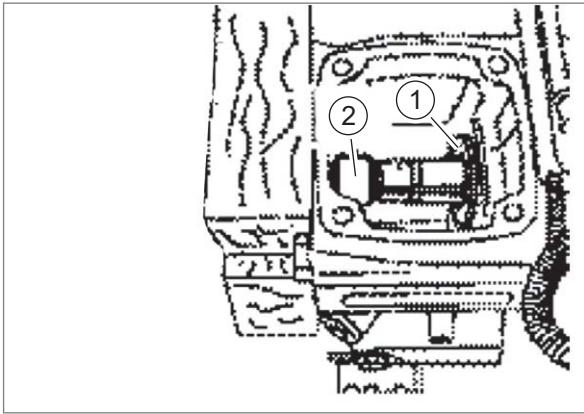

184958-001

505

- ▶ Remove inner bearing flange (1) with an internal puller (2).

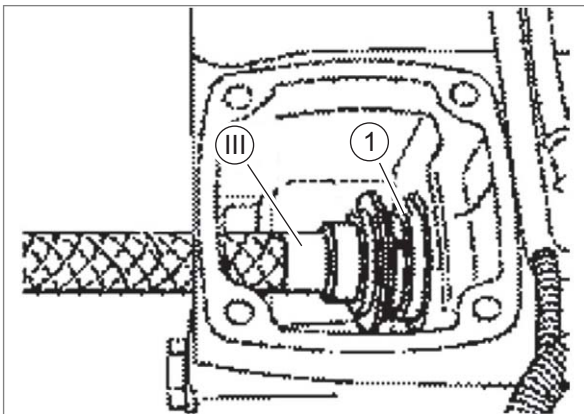

184959-001

506

Installing the crankshaft and connecting rod

- ▶ Check the inner diameter (b) of the inner bearing flange.
Inner diameter: [Page 308](#)
- ▶ Install inner bearing flange (1) with special tool (III).

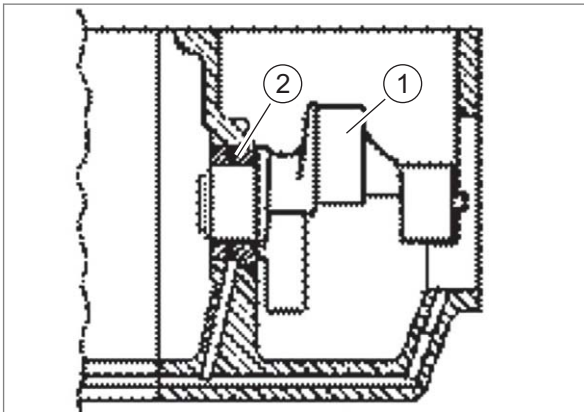

184962-001

507

- ▶ Check the diameter of the crankshaft connecting rod bearing pin (d).
Diameter (d): [Page 308](#)
- ▶ Insert crankshaft (1) into the inner bearing flange (2).

Checking the urea solution (purity)

This check detects traces of hydrocarbons, e.g. diesel fuel, in the urea solution.

The injection system components are very sensitive against hydrocarbons and can be damaged.

Flawless function of the exhaust gas treatment system then is **no longer** guaranteed.

- ▶ Disconnect the battery isolating switch of the machine.
- ▶ Wait for at least five minutes after stopping the diesel engine for the residual pressure in the system to be relieved.
- ▶ Remove urea filter as described in the relevant Operator's Manual.

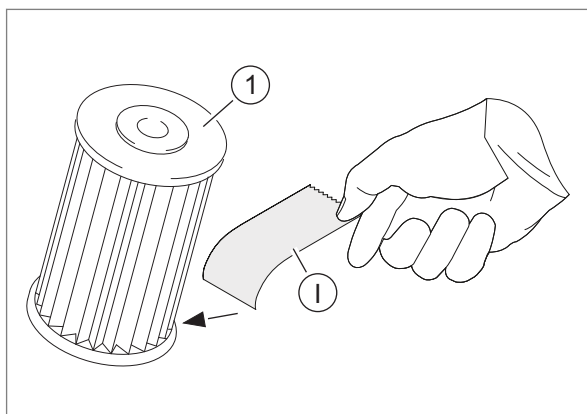

165543-001

522

- ▶ Slide a test strip of the special tool (1) between the lamellas of the removed filter (1) and impregnate it with the sticking urea solution.

A bright discolouration (2) of the test strip indicates that the urea solution is free of impurities (hydrocarbons).

A dark discolouration (3) or (4) of the test strip indicates that the urea solution is polluted with hydrocarbons.

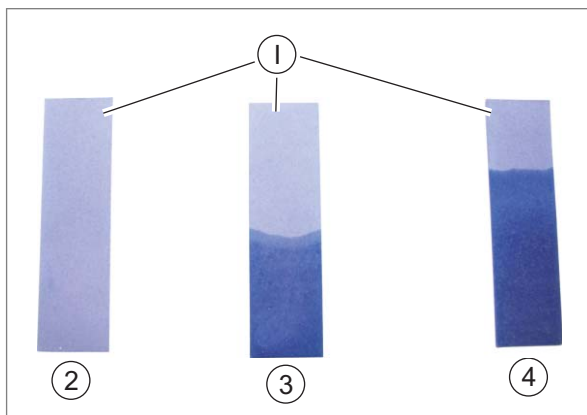

165544-001

523

- ▶ Install urea filter as described in the relevant Operator's Manual.

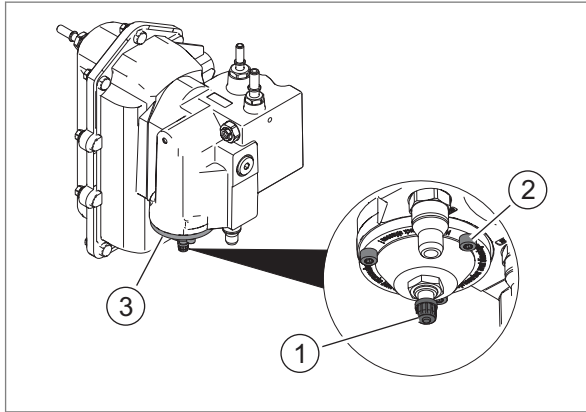

186176-001

541

Removing the pressure accumulator

- ▶ Keep valve (1) pressed until pressure accumulator (3) is completely empty.
- ▶ Unscrew bolts (2) and pull out pressure accumulator (3).

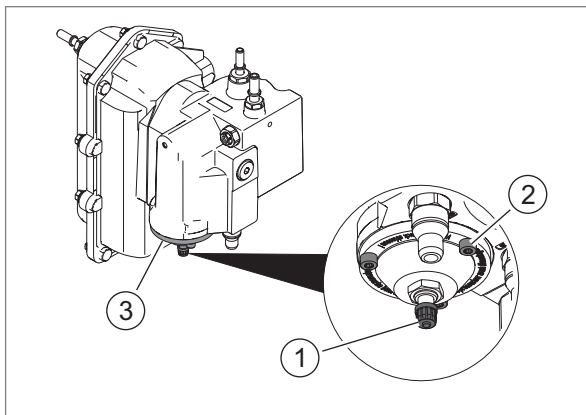

186176-001

542

Installing the pressure accumulator

- ▶ Insert pressure accumulator (3) with a new O-ring bolt down with bolts (2).
Tightening torque: [Page 337](#)
- ▶ Fill pressure accumulator (3) at (1). [Page 346](#).

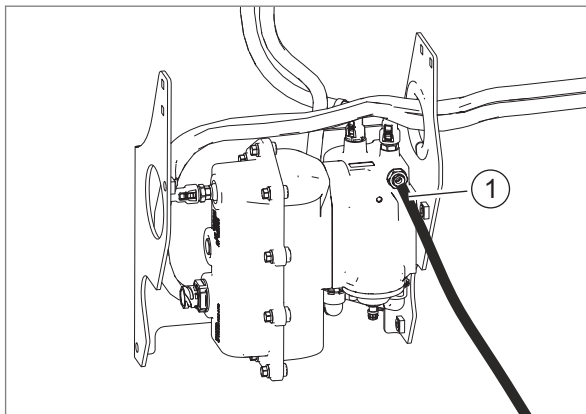

186189-001

543

Removing the dump valve

- ▶ Remove the compressed air line (1).



236419-001

- ▶ Unscrew sensor (B128-MB) carefully.
 - ▶ Take the remaining system pressure into account.

563

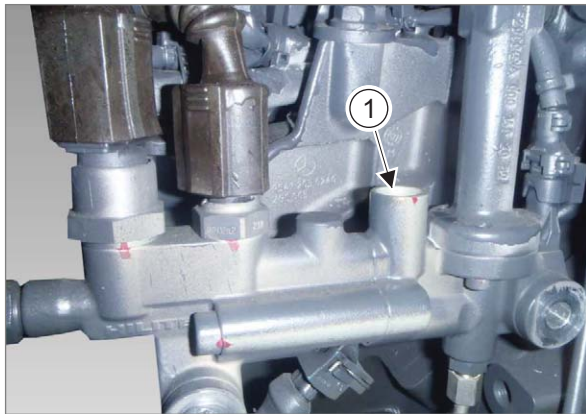

236420-001

- ▶ Fill water into drilled hole (1) until the drilled hole overflows.

564



236419-001

- ▶ Screw on sensor (B128-MB).
 - ▶ Tightening torque:  [Page 349](#)

565

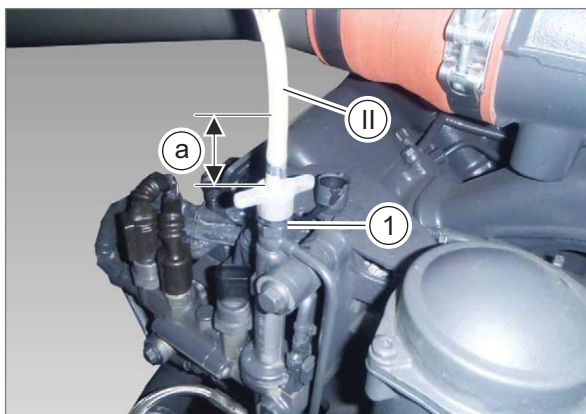

236421-001

Use special tool (II).  [Page 347](#)

- ▶ Bolt down special tool (II) at (1).
- ▶ Fill as much water into the flushing hose to produce a water column (a) of 4 cm.
 - ▶ To apply the water to the test connection, keep the flushing hose in a high position.
- ▶ Apply flushing hose with compressed air until the water has completely disappeared.
 - ▶ Do **not** exceed a maximum pressure of 5.5 bar!
- ▶ Remove special tool (II).
 - ▶ The test connection may remain on the urea dosing unit.

566

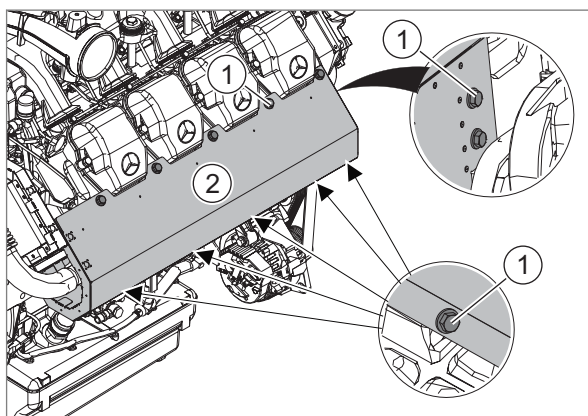

260061-001

587

- ▶ Unscrew bolts (1).
- ▶ Remove guard (2).

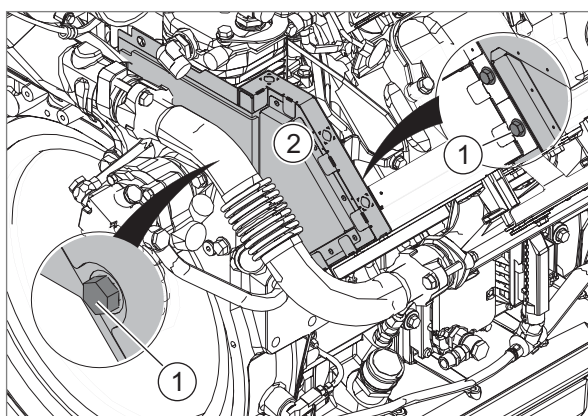

260062-001

588

- ▶ Unscrew bolts (1).
- ▶ Remove guard (2).

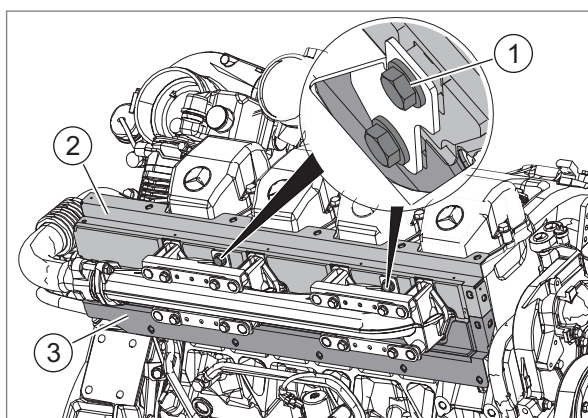

260063-001

589

- ▶ Unscrew bolts (1).
- ▶ Remove guards (2) and (3).

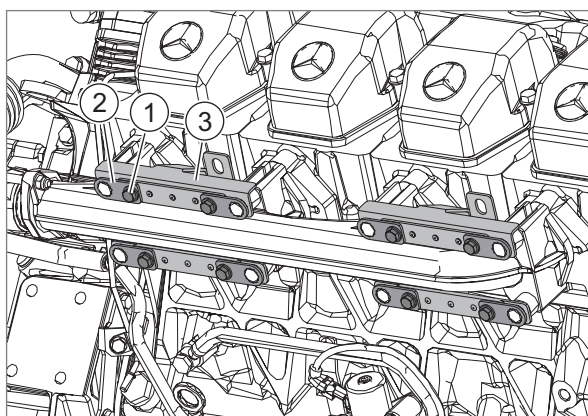

260064-001

590

- ▶ Unscrew bolts (1).
- ▶ Remove tab washers (2).
- ▶ Remove brackets (3).

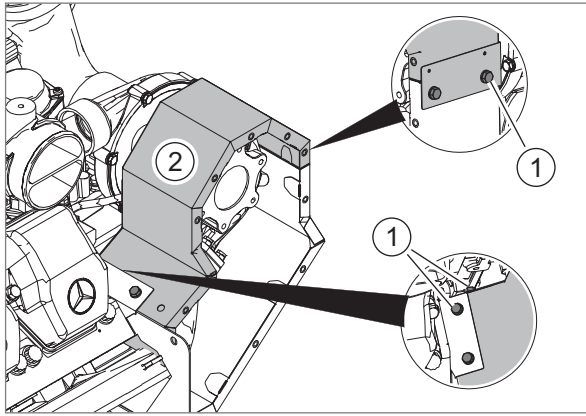

180154-001

618

- ▶ Unscrew bolts (1).
- ▶ Remove sheet metal guard (2).

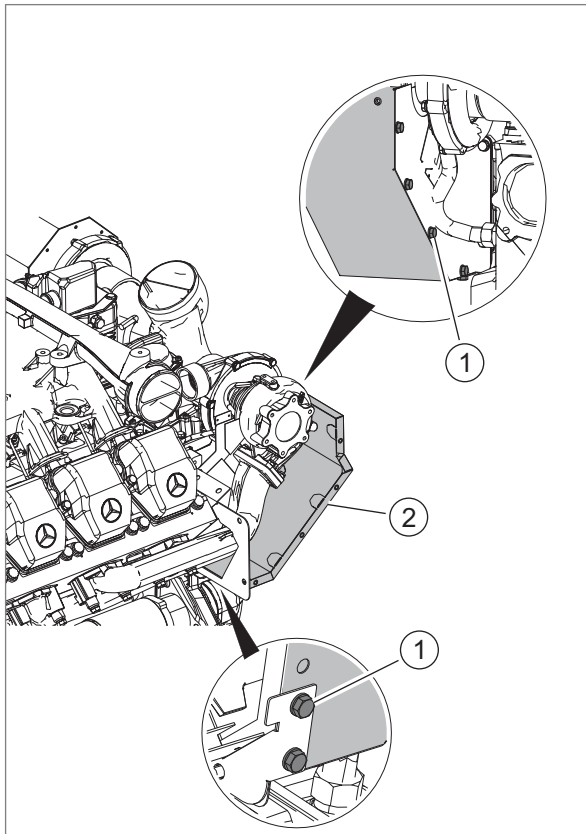

180155-001

619

- ▶ Unscrew bolts (1).
- ▶ Remove sheet metal guard (2).

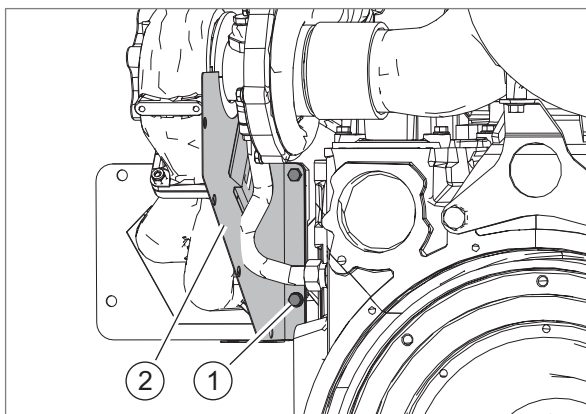

180156-001

620

- ▶ Unscrew bolts (1).
- ▶ Remove sheet metal guard (2).

- ▶ Remove the exhaust manifold. [👁 Page 253](#)

CLICK HERE TO **DOWNLOAD** THE COMPLETE MANUAL

- Thank you very much for reading the preview of the manual.
- You can download the complete manual from: www.heydownloads.com by clicking the link below



- Please note: If there is no response to CLICKING the link, please download this PDF first and then click on it.

CLICK HERE TO **DOWNLOAD** THE COMPLETE MANUAL