

**CASE**

PROFESSIONAL PARTNER

# REPAIR MANUAL COMPACT WHEEL LOADER

**21E  
121E  
221E  
321E**

87630260 NA  
Replaces 87618251 NA

Issued 02-2007  
Revised 03-2007

CLICK HERE TO **DOWNLOAD** THE COMPLETE MANUAL

- Thank you very much for reading the preview of the manual.
- You can download the complete manual from: [www.heydownloads.com](http://www.heydownloads.com) by clicking the link below



- Please note: If there is no response to CLICKING the link, please download this PDF first and then click on it.

CLICK HERE TO **DOWNLOAD** THE COMPLETE MANUAL

*SECTION 00 - INTRODUCTION*

---

---

## 1.11 WASTE DISPOSAL

Improperly disposing of waste can threaten the environment.

Each country has its own Regulations on this subject. It is therefore advisable to prepare suitable containers to collect and store momentarily all solid and fluid materials that must not be scattered in the environment to avoid pollution.

At preset intervals these products will be delivered to disposal stations legally recognized and present in this Country.

Hereunder are listed some products of the machine requiring disposal:

- lube oil;
- brakes system oil;
- coolant mixture, condensation rests and pure anti-freeze;
- diesel oil;
- oil and diesel oil filter elements;
- engine and air conditioning air filter elements;
- battery.

Also polluting rags, paper, sawdust and gloves must be disposed in compliance with the same procedures.

Do not use food or beverage containers that may mislead someone into drinking from them. Do not pour waste onto the ground, down a drain, or into any water sources. Air conditioning coolants escaping into the air can damage the Earth's atmosphere. Government regulations may require a certified air conditioning service centre to recover and recycle used air conditioning coolants. Obtain information on the proper way to recycle or dispose of waste from your local environmental or recycling centre, or from your Dealer.

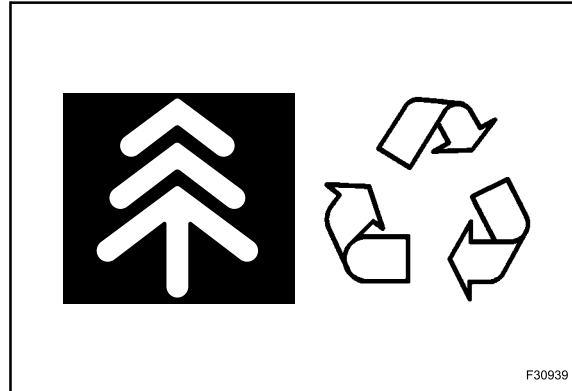

**HYDRAULIC MOTOR**

		21E	121E	221E	321E
Type		A6VM80HA1U1 / 63W			A6VM107HA1U1 / 63W
Displacement $Q_{max} / Q_{min}$	cm <sup>3</sup> (in <sup>3</sup> )	80 / 18.8 (4.88 / 1.15)	80 / 23.7 (4.88 / 1.44)	80 / 24.8 (4.88 / 1.51)	107 / 31.5 (6.53 / 1.92)
Maximum service revolutions	rpm	4362	5289	5292	4811
Delivery pressure	bar (psi)	25 (362)	25 (362)	25 (362)	25 (362)
Service pressure	bar (psi)	245 (3552)	190 (2755)	185 (2682)	200 (2900)
Pressure increasing spring	bar (psi)	20 (290)	10 (145)	10 (145)	10 (145)
Voltage	V	12			

**2.8 ELECTRICAL SYSTEM**

Service voltage..... 12 V

**Battery:**

Capacity (20 h)..... 92 Ah

Critical current ..... 900 A

**Alternator** ..... 55 A

**2.9 BUCKETS**

		21E			121E		221E		321E		
SAE capacity	m <sup>3</sup> (ft <sup>3</sup> )	0.65 (23)	0.70 (24.7)	0.80 (28.2)	0.80 (28.2)	0.90 (31.8)	0.90 (31.8)	1.00 (35.3)	1.00 (35.3)	1.10 (38.8)	1.20 (42.4)
Width	mm (ft)	1800 (5.9)	1900 (6.2)	1900 (6.2)	2050 (6.7)	2050 (6.7)	2050 (6.7)	2100 (6.900)	2100 (6.9)	2100 (6.9)	2100 (6.9)
Weight	kg (lb)	250 (551)	265 (584)	295 (650)	315 (694)	335 (738)	335 (738)	365 (805)	365 (805)	370 (816)	410 (904)

## 2.2 FUEL

Use commercially available diesel fuel with less than 0.5% sulphur content. If the sulphur content is higher, oil change intervals should be reduced. The following fuel specifications / standards are approved:

- DIN EN 590
- BS 2869
- ASTM D 975-96; 1-D and 2-D
- NATO Code F-54 / F-34 / F-44 and XF 63

Exhaust emission values which may be determined in the case of type approval tests always refer to the fuels prescribed by the authorities for the type approval test.

### WINTER-GRADE FUEL

Waxing may occur at low temperatures, clogging the fuel system and reducing engine efficiency.

If the ambient temperature is less than 0 °C (32 °F) use winter-grade fuel, suitable down to -15 °C (5 °F) should be used; this fuel is available at the filling stations well in advance of the cold season. Diesel fuel containing additives (Super diesel) is often available, for use down to -20 °C (-4 °F) approximately.

- At temperatures below -15 °C or -20 °C (5 °F or -4 °F), add petroleum to diesel fuel. The relevant percentages are given in the adjacent diagram.

If summer-grade diesel fuel must be used at temperatures below 0 °C (32 °F), up to 60% petroleum can be added (see diagram).

In most cases, adequate resistance to cold can also be obtained by adding a fluidizing additive for winter operation.

Legend:

- I Summer-grade diesel fuel
- II Winter-grade diesel fuel
- A Outer temperature
- B Percentage of petroleum

### ⚠ CAUTION

Diesel fuels must never be mixed with gasoline (Normal and Super grades).

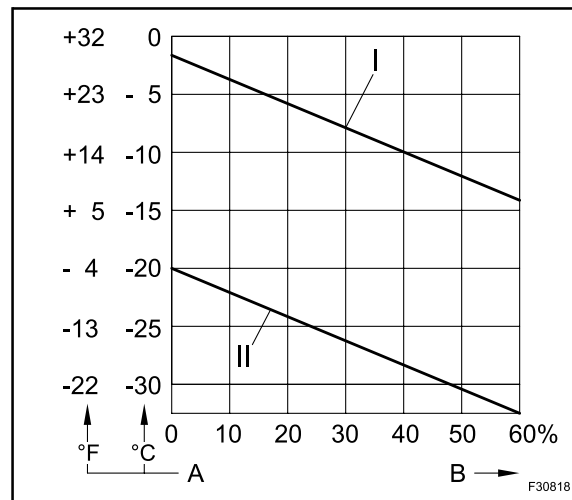

## 5. DISASSEMBLY AND ASSEMBLY

### 5.1 BRAKE DISC ASSY

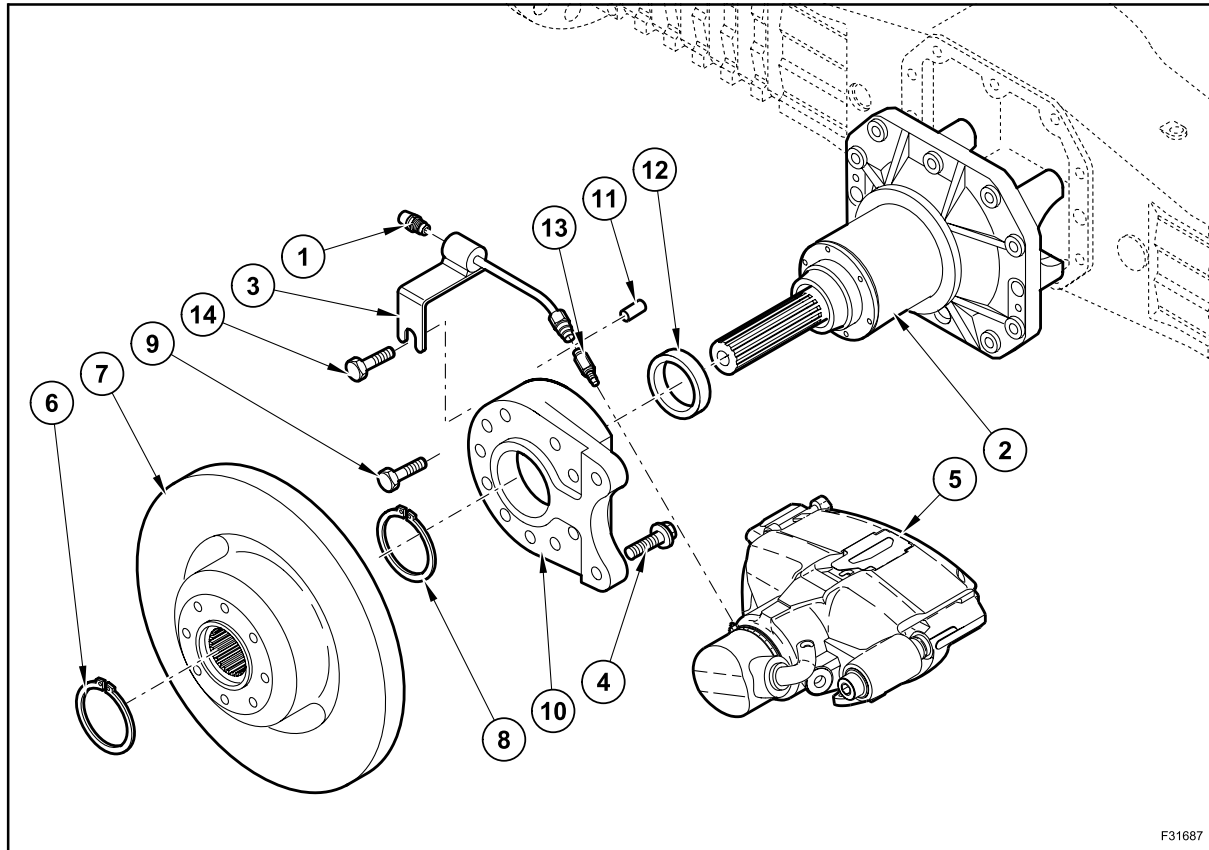

F31687

#### DISASSEMBLY

Some of the following pictures could not show exactly the axle, but the procedure is the same.

Remove the breather (1). Loosen the screw (14). Remove the connector (13) and the breather pipe (3) from the brake caliper (5).

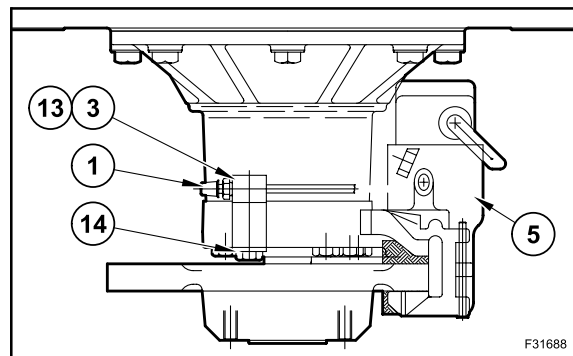

F31688

Fit a puller hooking it to the groove of parking brake protection.

To compress the cover and the spring use pusher 380002234 (a1).

Screw in puller screw (a2).

Remove the camshaft (2).

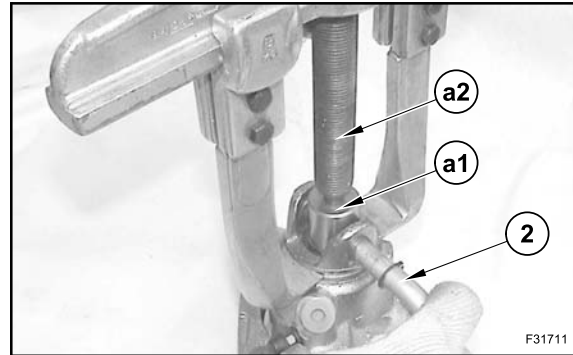

Remove puller and pusher.

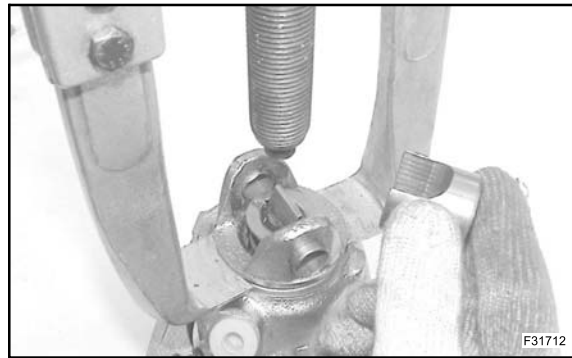

Remove the pusher (3).

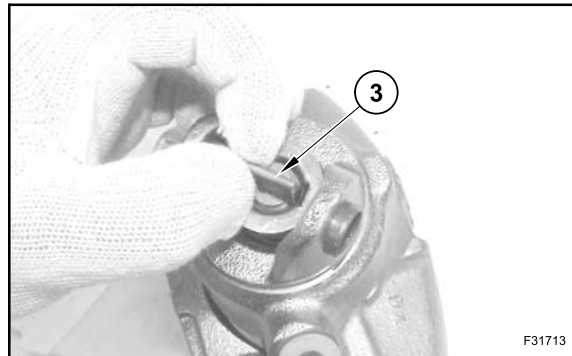

Unscrew the tie-rod (4).

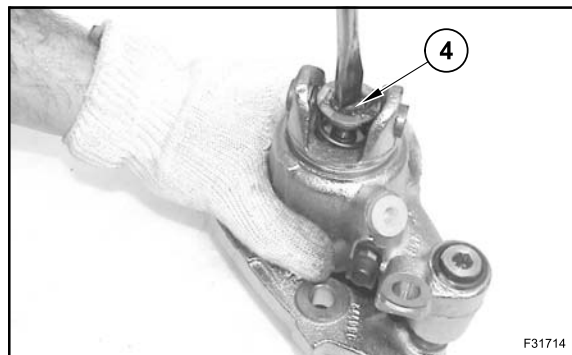

Unscrew and remove the both fastening screws (3) of the planetary gears carrier (1).

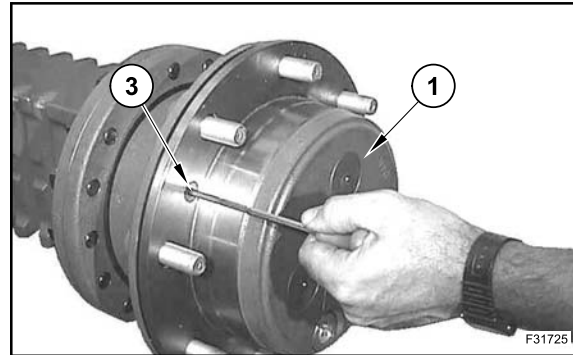

Remove the planetary gears carrier (1) from the wheel hub and remove the relevant O-ring (4). Position the planetary gears carrier (1) on a work-bench and check its wear conditions.

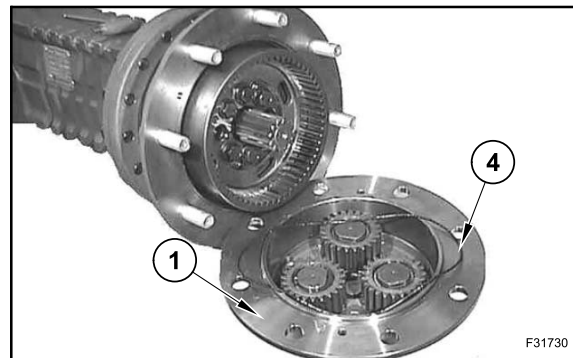

To carry out any possible replacement of the gears (7):

- remove the snap rings (10) on every pin (5);
- remove the thrust washers (9);
- take out the gears (7) from the pins (5);
- collect the needle bearings (6) and (8) checking their condition.

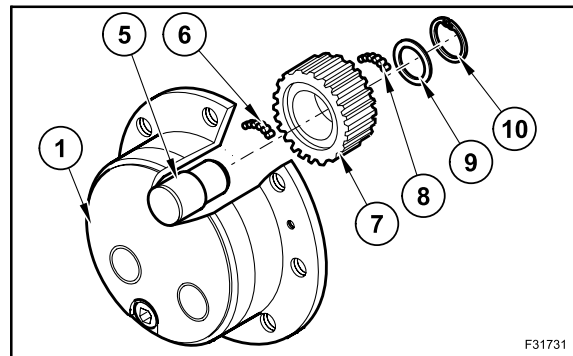

Apply the prescribed sealant on the stud bolt threads (10) and tighten them to the prescribed torque of 70 Nm (51 lbf-ft) using two nuts (nut and lock nut).

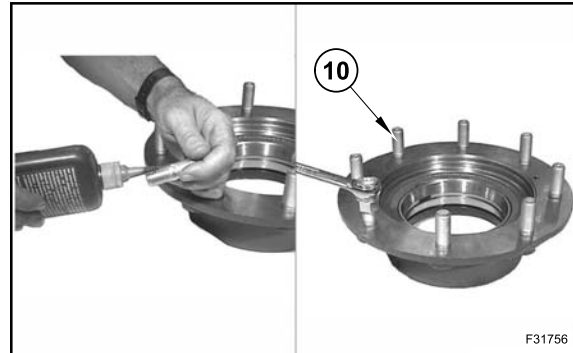

Position the wheel hub (6) on a workbench and force the two bearing cups (7) and (9) in position with a driver 380002222 with a press or with a hammer.

Assemble the seal ring (8) into the wheel shaft (6) with the driver 380002227 and a hammer.

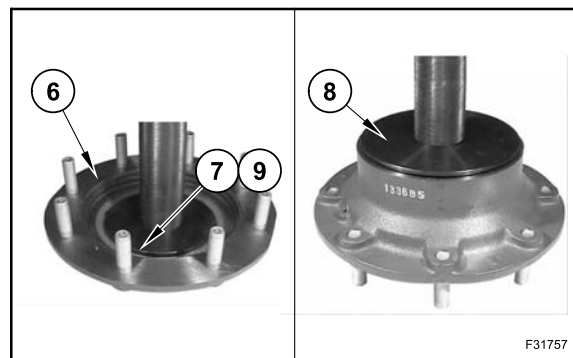

Insert the wheel hub (6) on the wheel shaft.  
Heat the bearing (7) to  $80 \div 100$  °C ( $176 \div 212$  °F).  
Assemble the bearing.

**⚠ WARNING**

Wear safety gloves.

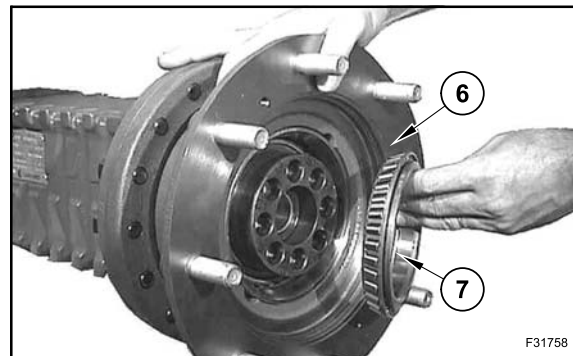

Position the wheel carrier assy (2) on a workbench and assemble bushings (4) at surface level with the driver 380002223.

At least two bushings (diametrically-opposed) should be set slightly higher than the carrier surface level to be used as dowel pins.



Slide out the long half shaft (17) from the axle beam. Remove the splined sleeve (15). Remove the snap ring (16) from splined sleeve inner, if replacement is required.

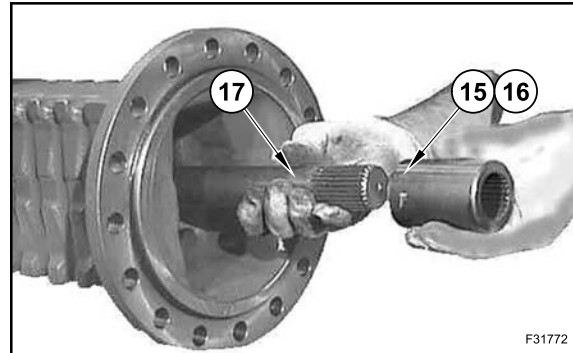

### ASSEMBLY

Some of the following pictures could not show exactly the axle, but the procedure is the same.

Assemble bush (5) on the wheel shaft with the driver 380002229 and a hammer.

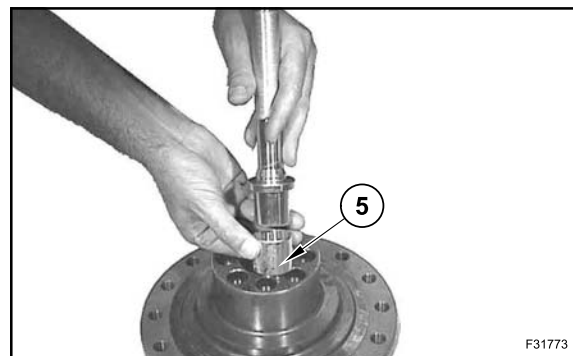

Overturn the wheel shaft.  
Assemble the seal ring (6) in the wheel shaft with the driver 380002221 and a hammer.

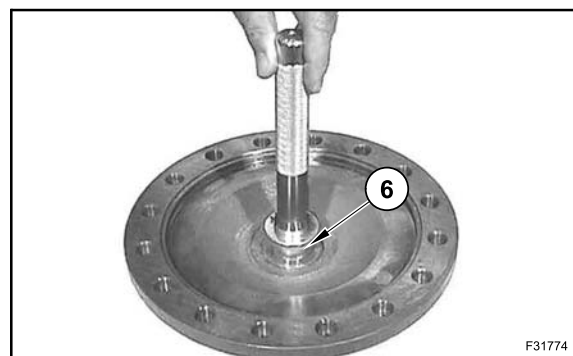

## 5.9 DIFFERENTIAL SUPPORT ASSY

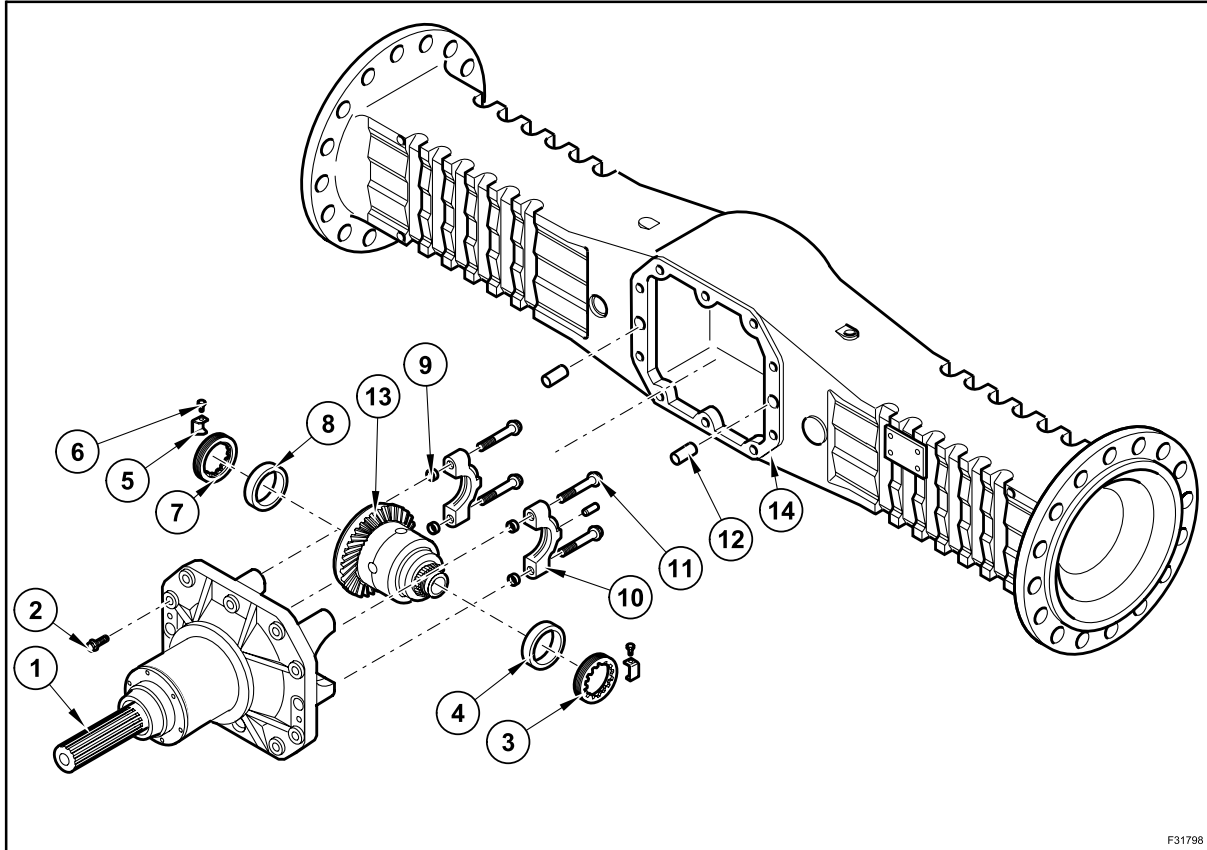
**DISASSEMBLY**

Some of the following pictures could not show exactly the axle, but the procedure is the same.

Drain the oil completely from the differential.  
Unscrew and remove the screws (2).

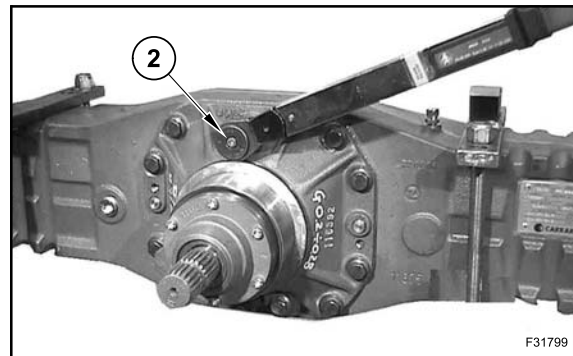

Remove the discs (5) and (6).

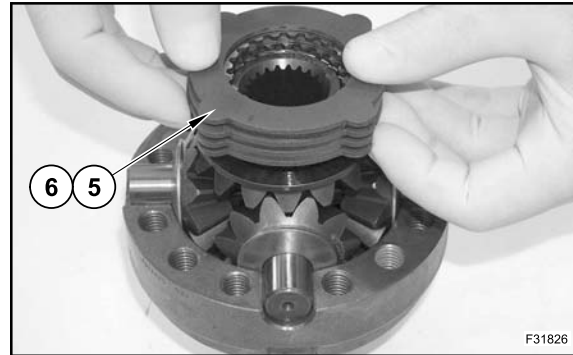

Remove the gear (8) with the thrust washer (7).

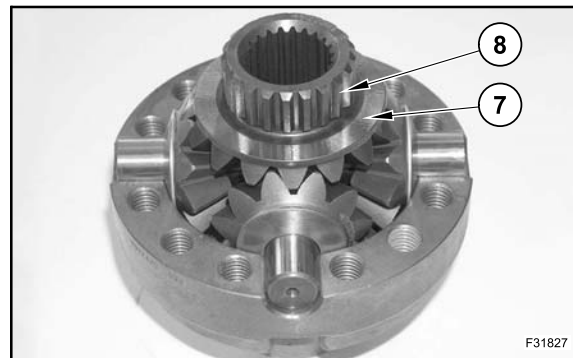

Remove the pins (9) and (14), the planetary gears (10), (13), (15) and (17) and the spherical washers (22), (12), (16) and (18).

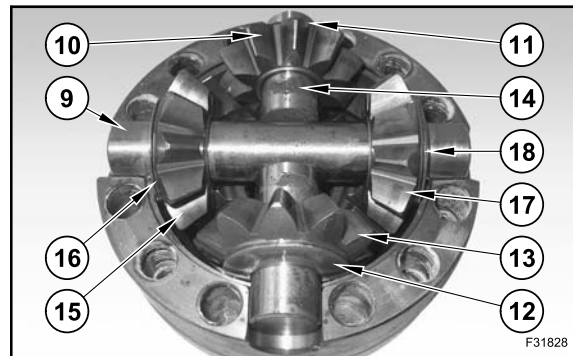

Remove the gear (19) with the thrust washer (20).



Insert the washer (9) and screw up a new lock ring nut (10) on the pinion end.

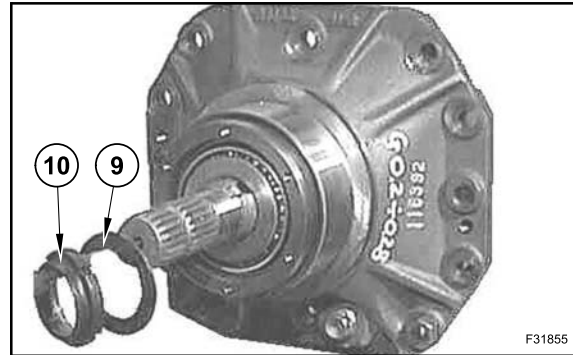

Screw up the lock nut with the wrenches 380002212 and 380002218.

**⚠ WARNING**

The torque setting is given by the preloading measurement on bearings. Tighten the ring nut step by step.

**NOTE:** if it is tightened too much, the collapsible spacer should be replaced and the procedure repeated.

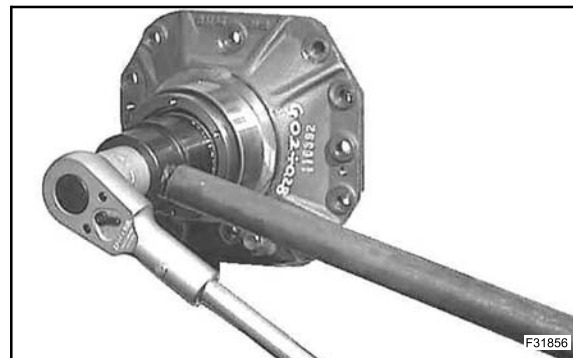

When you check the preloading, strike the pinion ends with a soft hammer to favour the bearings settlement.

Carry out the bearings preloading measurement (P) of the bearings, using a dynamometer whose cord is wound on the splined pinion end (1). The adjustment is carried out by increasing the ring nut torque setting gradually, being careful not to exceed.

**⚠ WARNING**

All preloadings must be measured without seal ring.

$$P = 9.2 \div 13.7 \text{ daN (20.6} \div \text{30.8 lbf)}$$

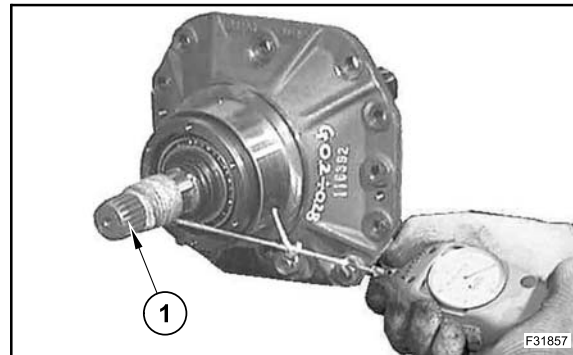

---

**NOTE:** the drawing shows a standard rear axle, the procedure for high speed axle is the same.

---

### REMOVAL

- Park the machine on a level surface.
- Lift the loader and support it safely.
- Shut off the engine and remove the ignition key.
- Activate the parking brake.
- Release the pressure from the hydraulic system.
- Remove the cups (8) and unscrew nuts (7) from both sides.
- Remove the two wheels (6).
- Disconnect the cardan joint (10).
- Position the fork-lift truck laterally with the forks under the rear axle (1), lift the rear axle and support it.
- Disconnect pipes (5) and (9).
- Disconnect pipes (11) and (12) from hydraulic motor.
- Unscrew and remove screw (2) and nut (3).
- Slide out the pin (4).
- Lower the forks and remove the rear axle (1).

### INSTALLATION

- The assembly of the rear axle is to be carried out in the reverse order.
  - Fill in oil in the reduction gears, in the transmission box and axle body.
  - Lubricate the axle swinging.
-

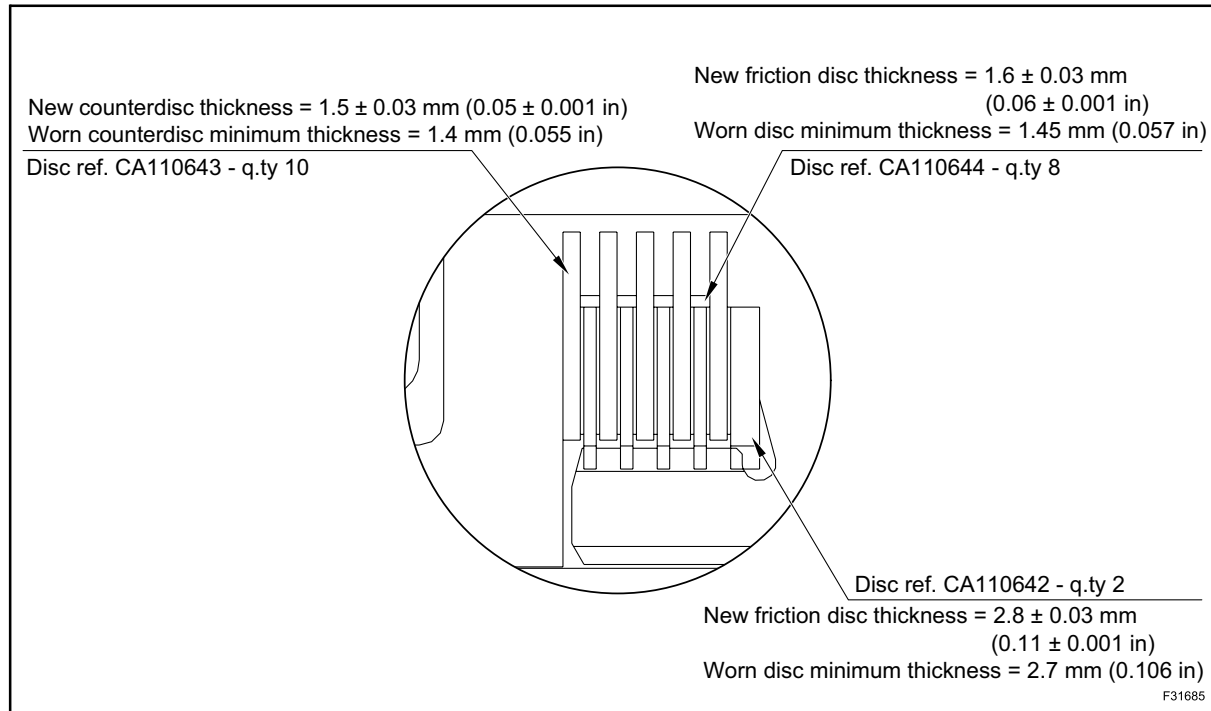
**LIMITED SLIP DIFFERENTIAL DISCS THICKNESS**

Position the transmission box (4) on a workbench. Remove the snap ring (12) from the shaft (1). Remove the shaft (1) from the transmission box (4) with a hammer and a driver. Remove the cover (2) from the shaft (1), if necessary.

**NOTE:** destructive operation for the cover (2).

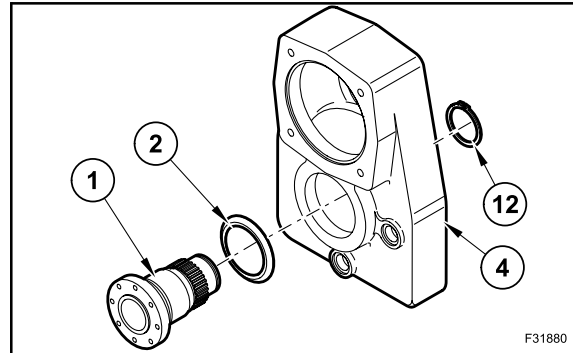

Unscrew and remove the fastening screws (11) of the cover (10).

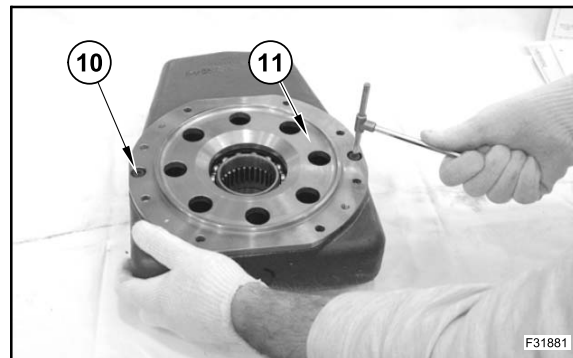

In order to remove the cover (10) from its seat, screw up two M8 screws in the extraction holes.

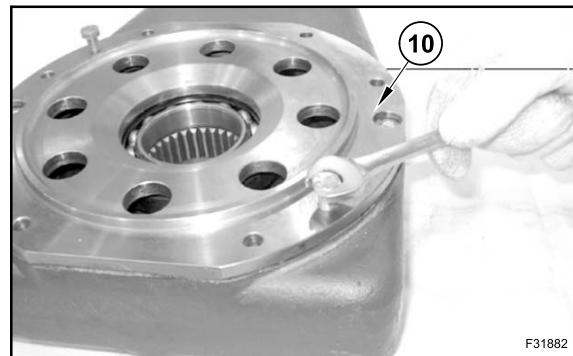

Remove the O-ring (7).

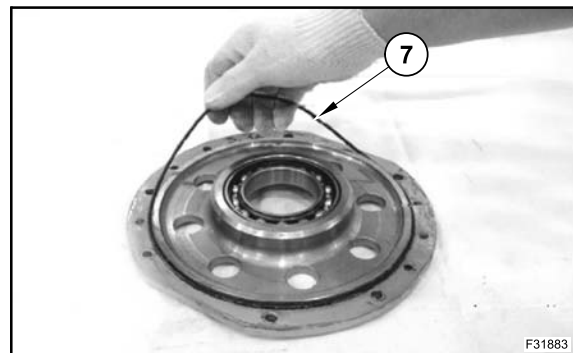

Remove the O-ring (41).

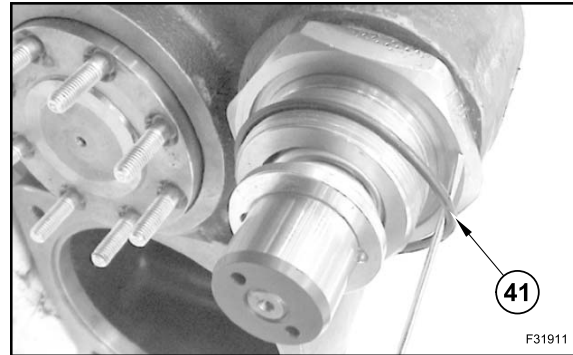

Unscrew the piston (45) with the wrench 380002244.

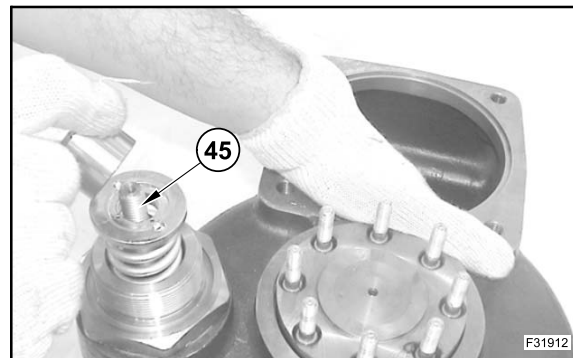

Remove the piston (45), the washer (44) and the spring (43).

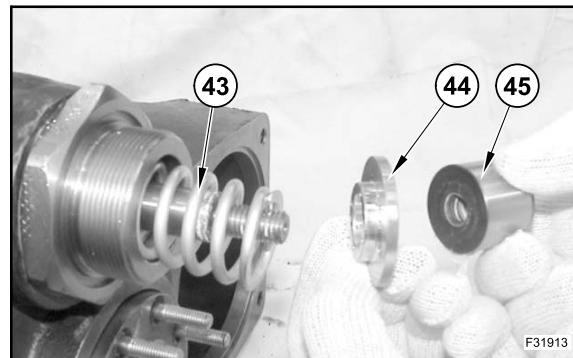

Remove the washer (42). Unscrew the splined sleeve (40). Remove the splined sleeve (40) and the O-ring (38).

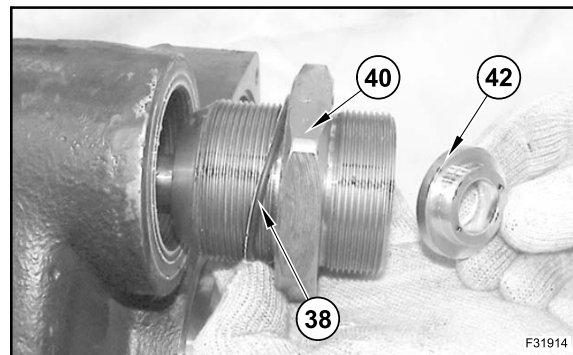

Assemble the snap rings (26) and (28) on the gear seats (27).

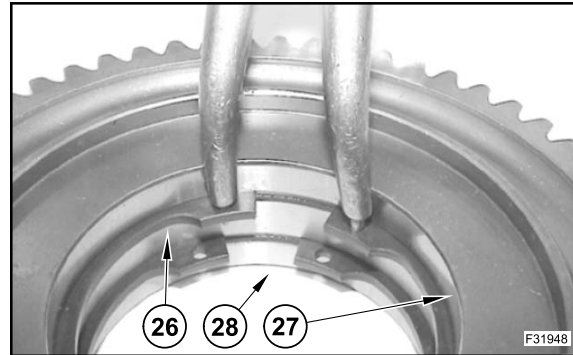

Assemble the bearing (29) on the gear (27).

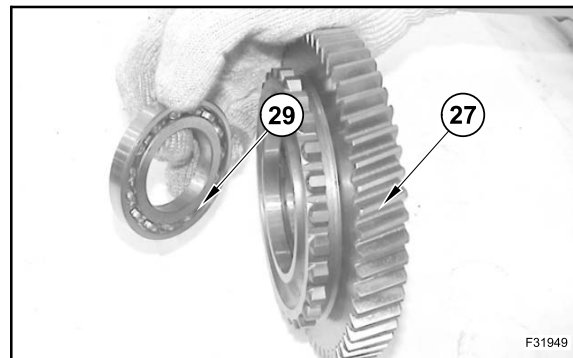

Assemble the gear assembly - bearing (27) and (29) on the shaft (37).

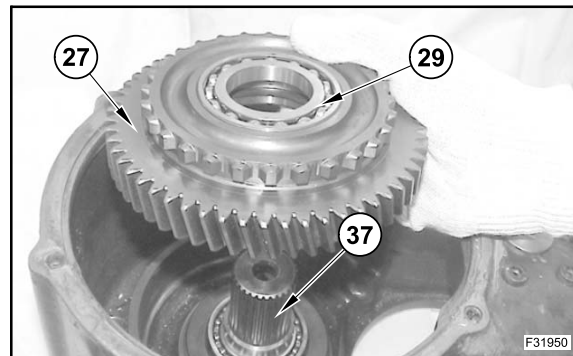

Use the driver 380002217.

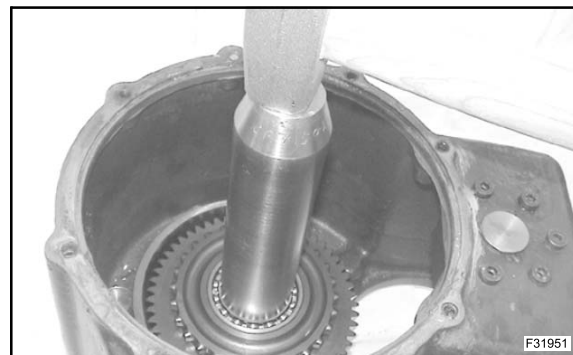

Unscrew and remove the two fastening screws (3) of the planetary gears carrier (1) with a wrench.

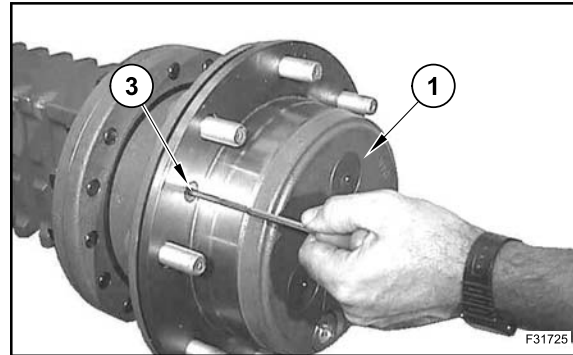

Remove the planetary gears carrier (1) from the wheel hub and remove the relevant O-ring (5). Position the planetary gears carrier (1) on a workbench and check its wear conditions.

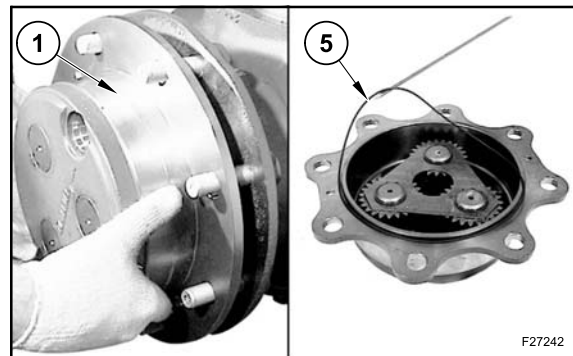

To carry out any possible replacement of the gears (7):

- remove the snap rings (10) on every pin (4);
- remove the triangular plate (9);
- take out the gears (8) from the pins;
- collect the needle bearings (7) checking their conditions;
- collect the thrust washer (6).

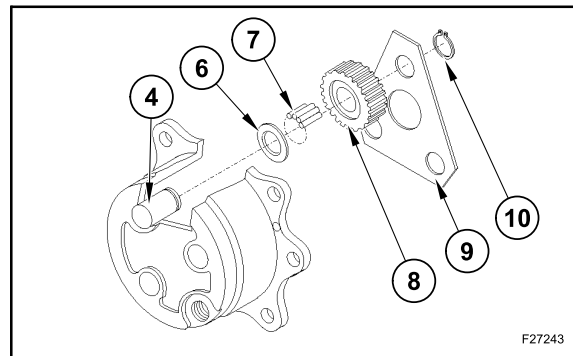

Remove the bearing (9) from the wheel shaft end using a commercial puller.

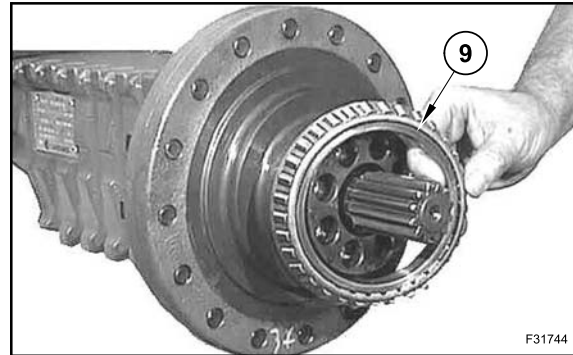

Remove the short half axle (11) from the wheel shaft.

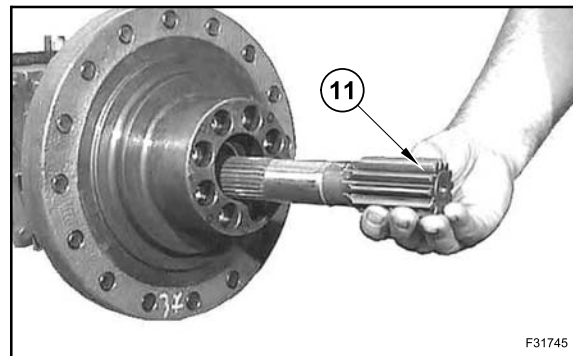

Unscrew and remove the wheel shaft fastening screws (12).

**⚠ WARNING**

Do not drop the wheel shaft; if necessary hold it by means of a sling.

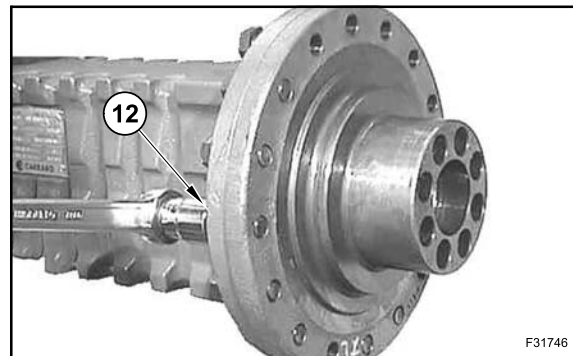

Remove the wheel shaft (13).  
Remove the O-Ring (14) and check its conditions.

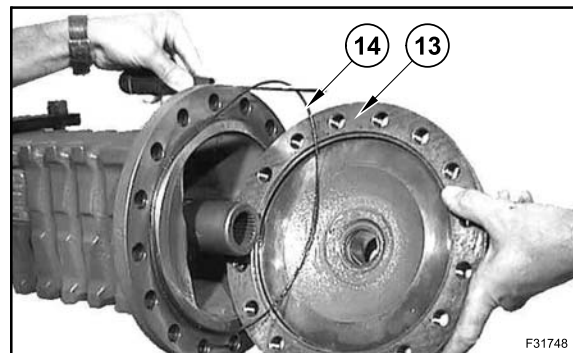

Apply the prescribed sealant on the stud bolt threads (10) and tighten them to the prescribed torque of 70 Nm (51 lbf-ft) using two nuts (nut and lock nut).

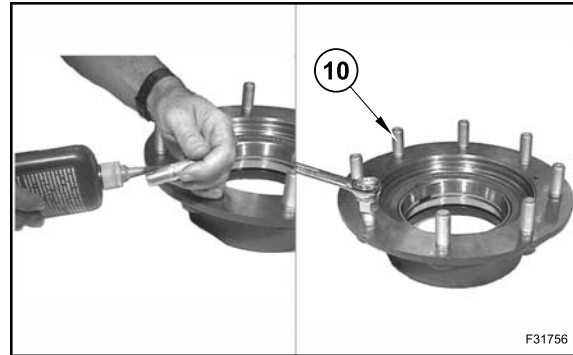

Position the wheel hub (6) on a workbench and force the two bearing cups (7) and (9) in position with a driver 380002222 with a press or with a hammer.

Insert the seal ring (8) on wheel shaft with the driver 380002213 and a hammer.

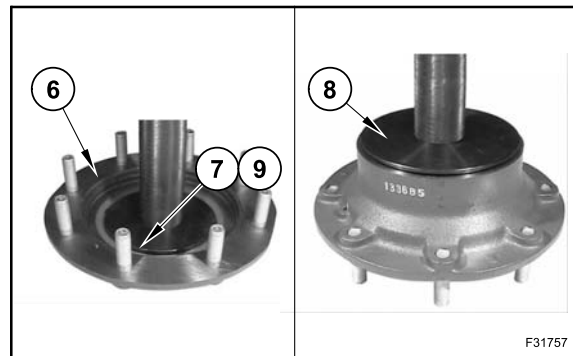

Insert the wheel hub (6) on the wheel shaft.  
Heat the bearing (7) to  $80 \div 100$  °C ( $176 \div 212$  °F).  
Assemble the bearing.

**⚠ WARNING**

Wear safety gloves.

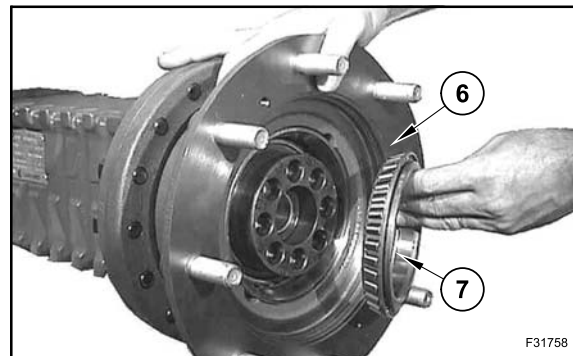

Position the wheel carrier assy (2) on a workbench and force bushings (4) at surface level with driver 380002231.

At least two bushings (diametrically-opposed) should be set slightly higher than the carrier surface level to be used as dowel pins.



Assemble the adjuster ring nuts (3) and (7) to the differential support.

Tighten both adjuster ring nuts (3) and (7) with the wrench 380000406 (a1) until the backlash is eliminated and slightly preload the differential bearings. Check that the differential bearings are well settled; if necessary, knock them slightly with a soft hammer.

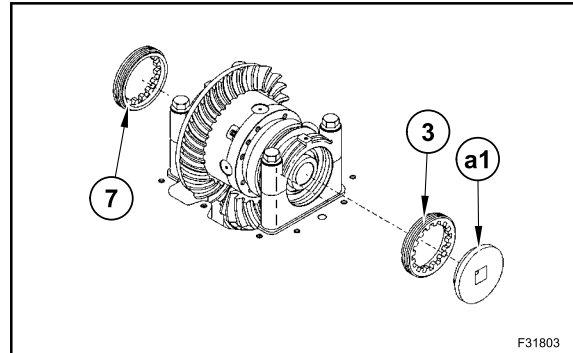

Position a magnetic-base dial gauge on the differential support, so that the feeler stylus touches the surface of one tooth of the crown gear with a 90° angle.

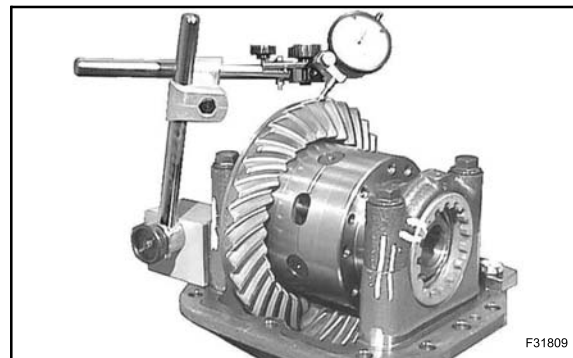

Lock the pinion and move the crown gear alternatively and note the ring gear backlash, measured with the comparator.

Repeat the operation on two or more points (teeth), rotating the crown gear, so that to obtain an average value.

Check if the measured backlash value is within the requested range:

$$0.17 \div 0.24 \text{ mm (0.0066} \div \text{0.0094 in)}$$

Carry out the adjustment by operating on the adjuster ring nuts with tool 380000406.

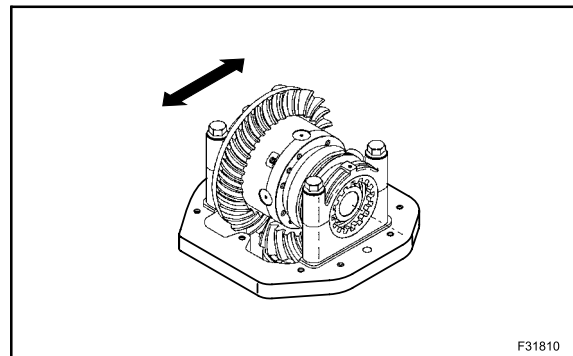

Fit the bevel gear crown (2) by using a hammer.

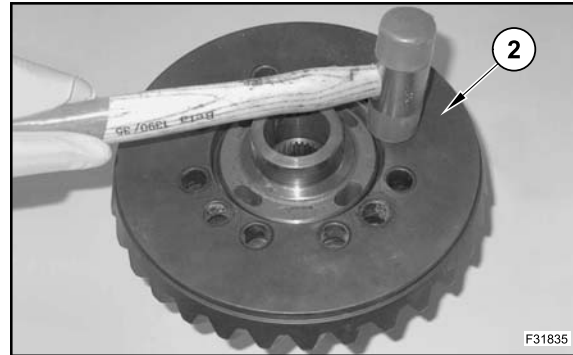

Apply Loctite 242 on the thread of the screws (1).



Tighten the screws (1) to the prescribed torque  
95 Nm (70 lbf-ft).

---

**NOTE:** fix differential housing in the vice.

---

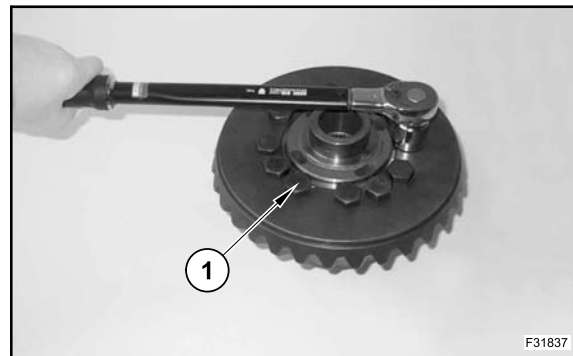

Install the bearing (3) with the driver 380002216.

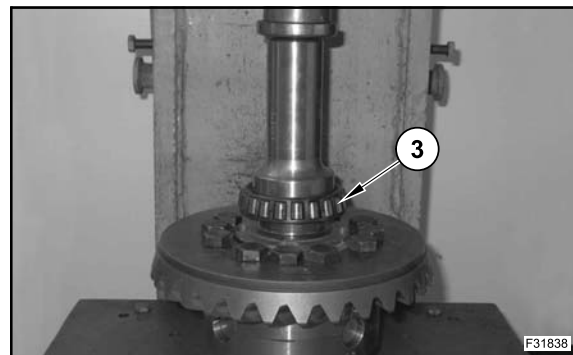

Tap the shaft end with a soft hammer to remove the bevel pinion (1).

**⚠ WARNING**

Take care not to drop the bevel pinion.

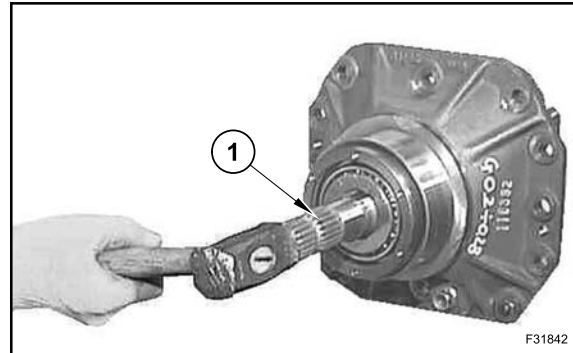

Remove the shims (4) and (6), the collapsible spacer (5), the bearing (8) and the washer (9).

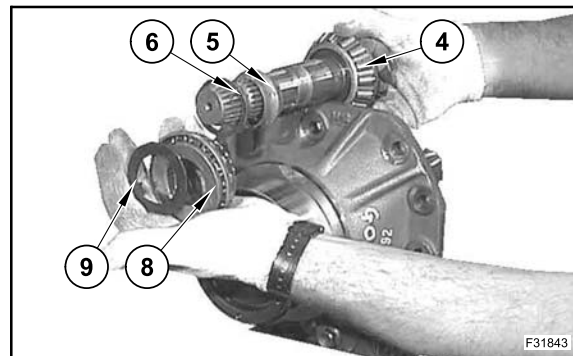

Take out the bearing cups (3) and (8) with a driver and a hammer.

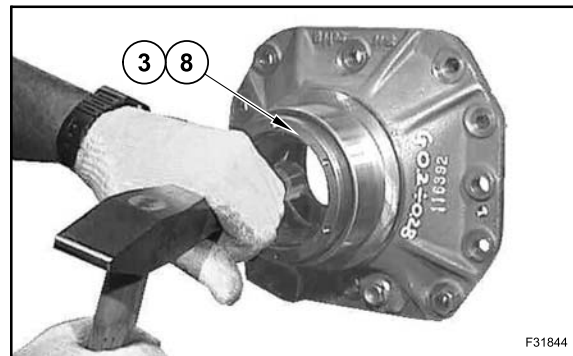

Remove the bearing (3) from the pinion (1) using a puller.  
Remove the bearing (3) and the shim (2).

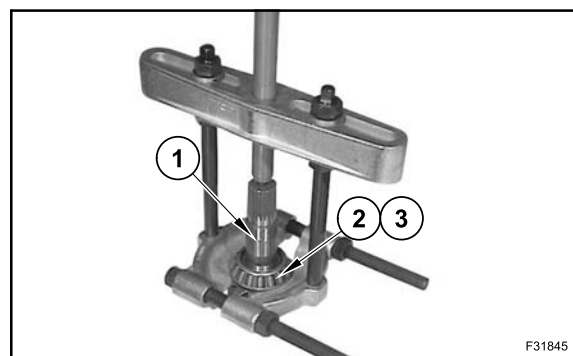

CLICK HERE TO **DOWNLOAD** THE COMPLETE MANUAL

- Thank you very much for reading the preview of the manual.
- You can download the complete manual from: [www.heydownloads.com](http://www.heydownloads.com) by clicking the link below



- Please note: If there is no response to CLICKING the link, please download this PDF first and then click on it.

CLICK HERE TO **DOWNLOAD** THE COMPLETE MANUAL

## 7. SPECIAL TOOLS

Drivers and buffers for seals, bearing and bushes assembly must be used with interchangeable the handle 380002211; their use is recommended with a safety handle for hands protection.

P/N CNH	APPLICATION	21E	121E	221E	321E
38000406	Wrench	•	•	•	•
38000407	False differential box	•	•	•	•
38000443	Driver	•	/	/	/
38002211	Handle	•	•	•	•
38002212	Wrench	•	•	•	•
38002213	Driver	/	•	•	•
38002214	False differential box	•	•	•	•
38002215	Driver	•	•	•	•
38002216	Driver	•	•	•	•
38002217	Driver	/	•	•	•
38002218	Wrench	•	•	•	•
38002219	False pinion	•	•	•	•
38002221	Driver	/	•	•	•
38002222	Driver	•	•	•	•
38002223	Driver	/	•	•	•
38002224	Driver	•	•	•	•
38000225	Driver	•	•	•	•
38002226	Driver	/	•	•	•
38002227	Driver	•	•	•	•
38002228	Buffer	•	•	•	•
38002229	Driver	/	•	•	•
38002231	Driver	/	•	•	•
38002233	Buffer	/	•	•	•
38002235	Buffer	•	•	•	•
38002236	Buffer	•	•	•	•
38002237	Buffer	•	•	•	•
38002238	Driver	•	•	•	•
38002239	Driver	/	•	•	•
38002240	Driver	/	•	•	•
38002241	Driver	/	•	•	•
38002242	Buffer	/	•	•	•
38002243	Driver	/	•	•	•
38002244	Wrench	/	•	•	•

Coupling	Use	Thread
B	Fan motor	M22 x 1.5
F	Accumulator pressure switch (80 bar (1160 psi))	M14 x 1.5
N	Hydraulic oil tank (through one-way distributor valve)	M18 x 1.5
P	Oil delivery from the brake pump	M22 x 1.5
R	Emergency steering	M10 x 1
R1	Accumulator	M14 x 1.5
IP	Inch port to axial pistons pump	1/4" BSP
IS	Hydraulic oil tank (through one-way distributor valve)	1/4" BSP
F1	Brake light pressure switch	M10 x 1
T1	Output to the service brake	M14 x 1.5

### HYDRAULIC DIAGRAM

1. Accumulator charging valve
2. Inch valve
3. Brake accumulator
4. Accumulator pressure switch
5. Brake light pressure switch

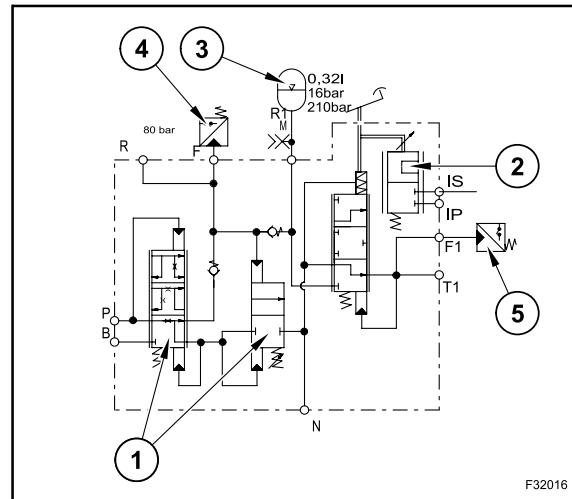

## 5. TROUBLESHOOTING

FAULT	CAUSE	ACTION
Abrupt braking.	Pressure setting incorrect.	Decrease pressure by handling on the setscrew under the pedal. During operation, pressure has to be checked with a pressure gauge.
Insufficient braking action.	Pressure setting incorrect.	Increase the pressure with the set-screw under the pedal. During operation, pressure has to be checked with a pressure gauge. WARNING: the admissible braking pressures must not be exceeded.
Delayed braking action and release of brake.	Insufficient charging and discharging speed of the brakes.  Viscosity of hydraulic oil too high.	Make sure the diameter of the lines in the brake system is not too small with respect to their length and the oil volume.  Fill the system with hydraulic oil of prescribed viscosity.
Brakes remain engaged.	Incorrect discharging of the brake system.  Brake pedal does not return to original position.	The system is not completely discharged and the residual pressure continues to act on the brakes.  Check that the stop screw of the pedal leaves some clearance between pedal return and actuating piston. Remove obstacles under the pedal, if any.
Brake lamp on instrument panel off or permanently lit up.	Pressure switch setting.	Adjust the pressure switch on the charging valve to a value below minimum pressure of the accumulators, but high enough to ensure 3 or 4 braking cycles after lighting up of the lamp.
Inconstant brake pressure.	The minimum pressure of the accumulator is lower than the brake maximum pressure.	Check the correct setting of accumulator pressure. If necessary, correct the value on the setscrew of the accumulator charging valve.

1. Diesel engine
  2. Pump at variable displacement
  3. Double gear pump
  4. Priority valve
  5. Front axle
  6. Rear axle
  7. Brake pedal valve
  8. Brake pedal valve accumulator
  9. Power steering
  10. Steering cylinder
  11. Travel hydraulic motor
  12. Hydraulic oil tank
  13. Hydraulic oil return filter
  14. Cooler
  15. Fan motor
  16. Load holding valve
  17. One-way distributor valve
  18. Working equipment control valve
  19. Quick tool coupler cylinders
  20. 3rd function cylinders
  21. Dumping cylinder
  22. Lifting cylinder
  23. Quick tool coupler cylinders valve
  24. Valve
  25. Accumulator
  26. Steering control valve
  27. High speed valve
  28. Safety valve
-

1. Diesel engine
2. Axial piston pump
3. Forward - reverse - idle gear actuator cylinder
4. Maximum pressure relief valve
5. Feed pressure relief valve
6. Regulator valve
- 6/1. Orifice
7. Pressure cut-off
8. Supply pump
9. Gear pump
10. Priority valve
11. Valve for forward, backward and reverse gear engagement and actuation
12. Travel hydraulic motor
13. Creep speed engagement valve
14. Absorption flow rate activation cylinder
15. Valve
16. Feed pressure valve
17. Hydraulic oil tank
18. Oil supply filter
19. Hydraulic oil return filter
20. Cooler
21. Check valve
22. Brake pedal valve
23. Inch valve
24. One-way distributor valve
25. Accumulator charging valve

**LEGEND**

1. Diesel engine - activates the system
2. Travel pump, at variable displacement - provides the pressure to hydraulic motor
4. Pressure relief valve - limits the high pressure in the system
5. Supply pressure relief valve - limits the feed pressure
8. Supply pump - supplies the system with control and supply oil
12. Hydraulic motor - sets the machine in motion

High pressure: pressure generated by the travel pump to drive the hydraulic motor.

Supply pressure: pressure generated by the supply pump.

Control pressure: pressure required to swivel out the travel pump.

---

**REGULATOR VALVE (B)****Adjustment start**

On measuring port ( $P_{HD}$ ) for forward speed connect a pressure gauge (measuring range 600 bar (8699 psi)). To measure the engine revolutions, you have to connect also a proper revolution counter (better if digital to be connected to injection pipes). Once the road travel speed has been engaged, move the loader against a wall or an heap of earth. Now the engine revolutions hold on  $1100 \pm 100 \text{ min}^{-1}$ . During this operation an high travel pressure ( $P_{HD}$ ), equal to 50 bar (725 psi) should be obtained.

To carry out adjustment, turn setscrew (2), after loosening the safety nut (5). By unscrewing the set-screw (2) the regulation start is "advanced", by tightening it the regulation begin is "delayed". Once the 50 bar (725 psi) for high pressure have been adjusted at a speed of  $1100 \pm 100 \text{ min}$ , the safety nut has to be retightened (5).

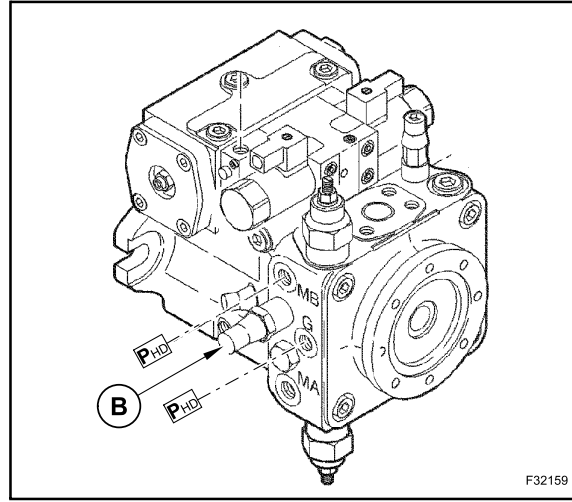
**⚠ WARNING**

The regulator valves (B) for 21E, 121E, 221E and 321E have each one different diaphragms (14).

This is the reason why the regulator valves are not interchangeable between one machine model and another.

1. Valve body
2. Setscrew
3. Safety nut
4. Spacer
5. Safety nut
6. Spring
7. Spring seat
8. Bushing
9. Ring
10. O-ring
11. Piston
12. Snap ring
13. Snap ring
14. Orifice
15. Piston housing

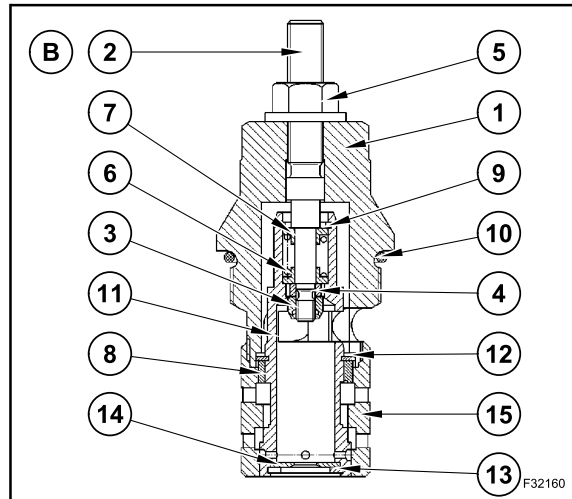

To remove the complete cover (2) use a screwdriver as shown in the figure.

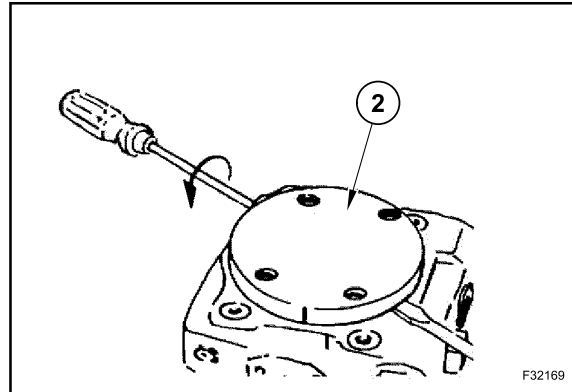

Unscrew the nut (2) and remove the control plate (6).  
Replace the O-ring (7).

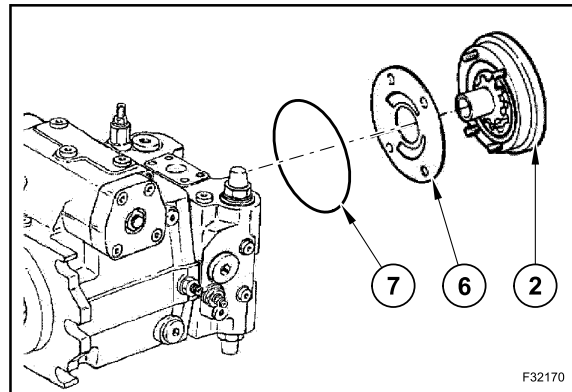

If requested:

- remove from the cover (2) the ring (9), the coupling (8) and the gears (5) and (4);
- replace the O-ring (3).

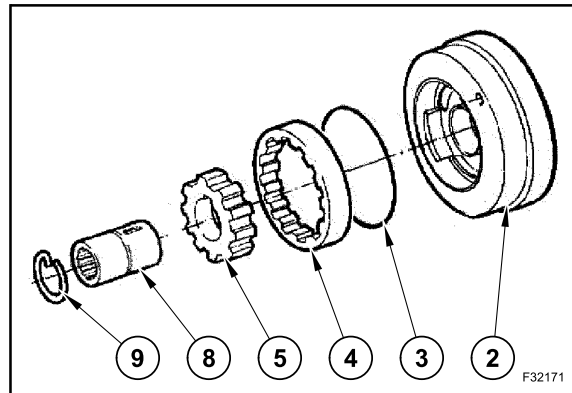

Remove the snap ring (1).

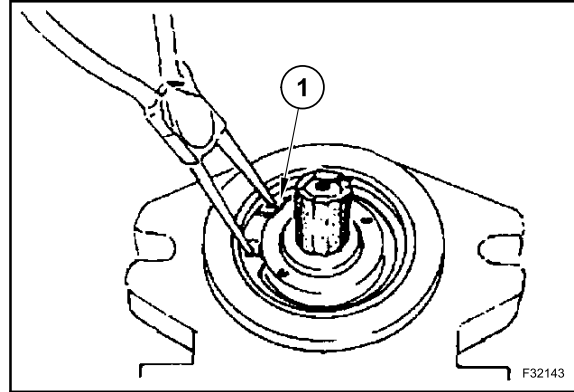

Screw the two screws (V) into the holes of seal ring (2).  
Remove the seal ring (2).

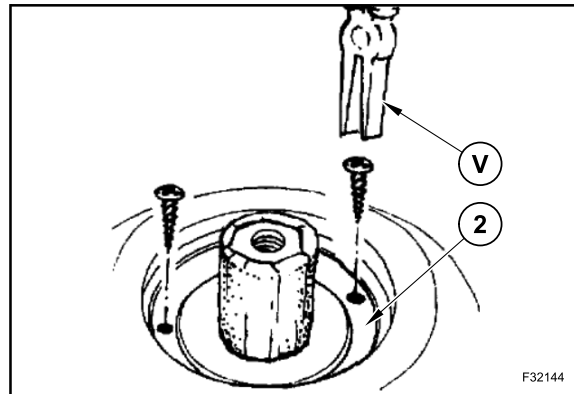

Untighten and remove the caps (4) and the pins (3).

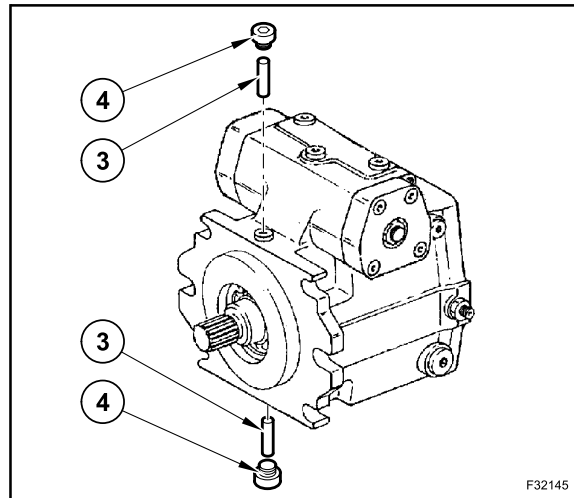

Press the cylinder to the bottom.  
Screw up the screw.  
Groove in mounting position.

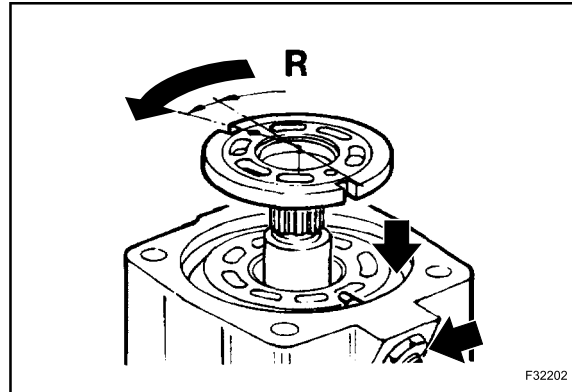

Assemble the valve plate assy with new O-ring.

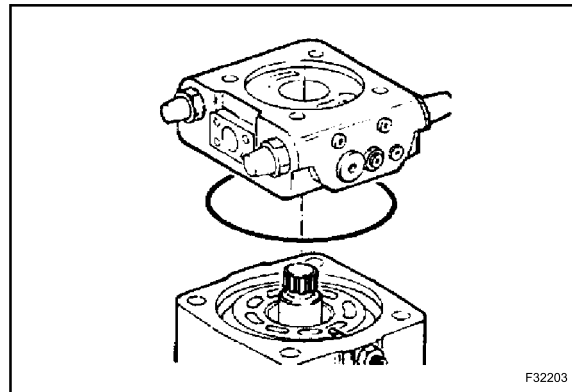

To seat the valve plate assy correctly, follow the mark applied during disassembly. Lock the valve plate assy by tightening the fixing screws.

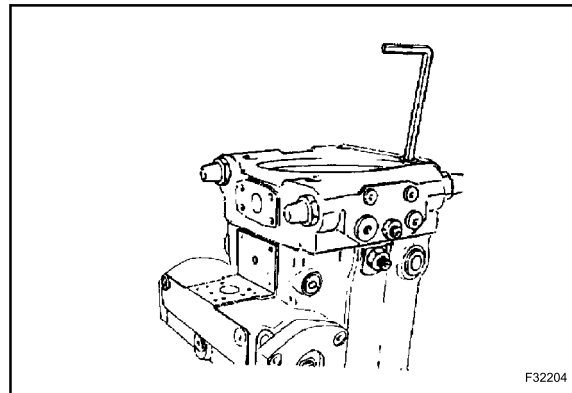

Assemble the auxiliary pump assy with control plate and a new O-ring.  
Fasten the auxiliary pump by means of fixing screws.

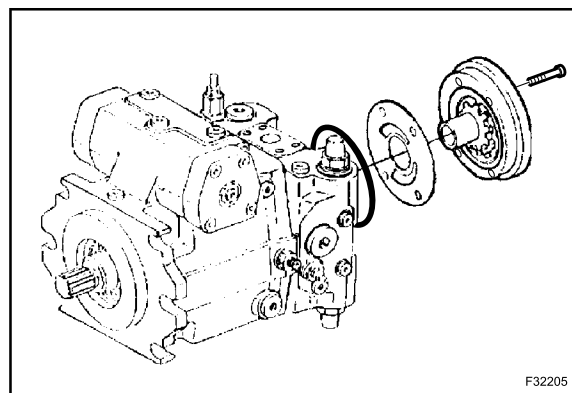

**OPERATION****Rotary assy**

The rotary assy consists of: control plate (1), seven pistons (2), drive shaft (3), cylinders block (4), spring (5), central pivot (6), bearings (7), seal ring (8).

The hydraulic oil pressure is applied by the control plate (1) to the piston, these under the thrust of oil perform the extension stroke, and being bound to the drive shaft, convert their motion into rotary motion of drive shaft.

The cylinders block turns with the pistons that by carrying out in sequence the extension stroke, generate an output torque on drive shaft.

The oil, after pistons displacement, is discharged on pistons return line during the retraction stroke.

The cylinders block can vary its tilting with relation to the shaft axis from  $5^{\circ}$  to  $25^{\circ}$ . When the tilting angle is changed, also the piston stroke changes and as a consequence the generated torque.

The output torque of the drive shaft depends on the hydraulic pressure and on the tilting of cylinders block, while the rotating speed depends on the oil flow and on the tilting of cylinders block; so if the cylinders block tilting is reduces, as a consequence the speed increases and the tractive force decreases, on the contrary, by increasing the angle the speed decreases and the traction force increases.

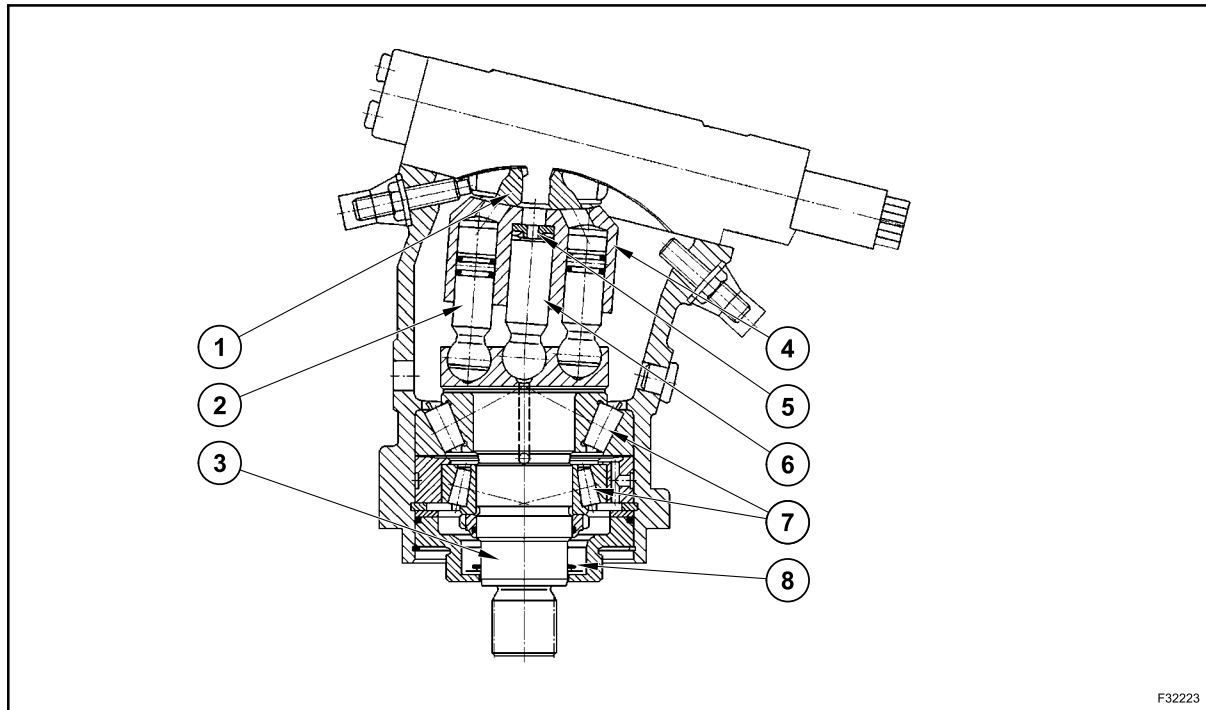

Check central pin for:  
• scores and pittings.

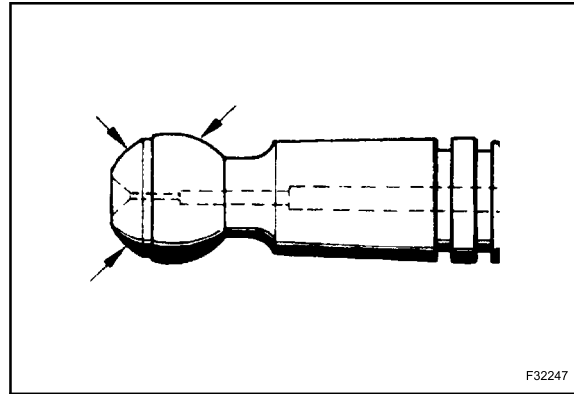

Check pistons for:  
• scores and pittings.

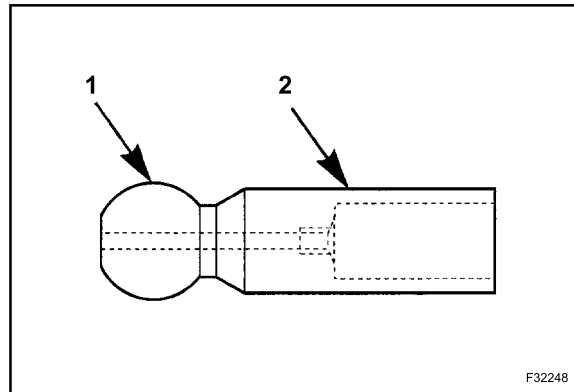

Check return plate for:  
• scores and wear.

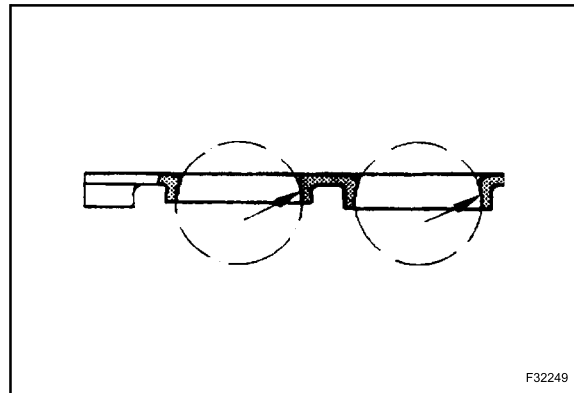

Check cylinder for:  
**A.** bores with scores and wear.  
**B.** even surfaces, without splits or scores.

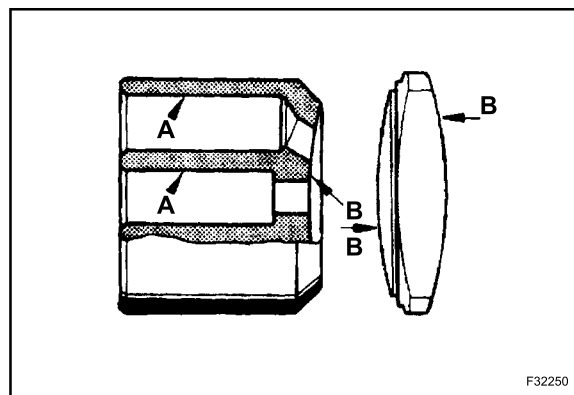

## 9. TROUBLESHOOTING

FAULT	POSSIBLE CAUSE	ACTION
Hydraulic system does not operate regularly.	Oil level low. Hydraulic filter clogged. Hydraulic system faulty.	Top up system. Replace hydraulic filter. Consult your Dealer.
Hydraulic oil overheated.	Oil level high or low. Oil filter element clogged. Delivery control wrongly adjusted.	Top up oil level. Replace filter. Adjust delivery control for lower delivery.
Hydraulics of steering and working system does not react.	Transmission coupling faulty.	Replace.
Machine does not move.	Hydraulic oil level too low.	Refill.
Engine does not come under load.	Operation faults in the pressure control circuit of travel pump. Travel motor not connected with rear axle. Parking brake still applied. Parking brake switch still stuck in opening position. Travel direction lever faulty.	Consult your Dealer. Recheck installation of travel motor. Release parking brake. Replace. Replace.
Engine under load.	Rear axle locked. Brake locked.	Check axle. Release brake.
Machine does not move either forward or back.	Travel direction valve faulty. Travel direction lever faulty.	Replace. Replace.
On a flat surface the machine starts only with high engine speed.	Supply filter contaminated.	Clean or replace.

*SECTION 41 - STEERING SYSTEM*

---

---

Carefully press the spool (2) out of the sleeve (1).

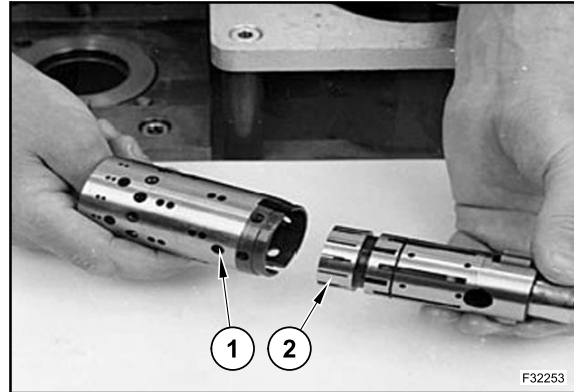

Press neutral position springs (10) out of their slots in the spool.

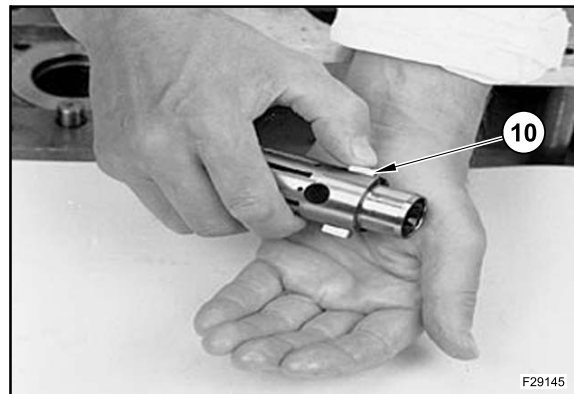

Remove the dust seal (24) and O-ring / Roto-Glyd (5).

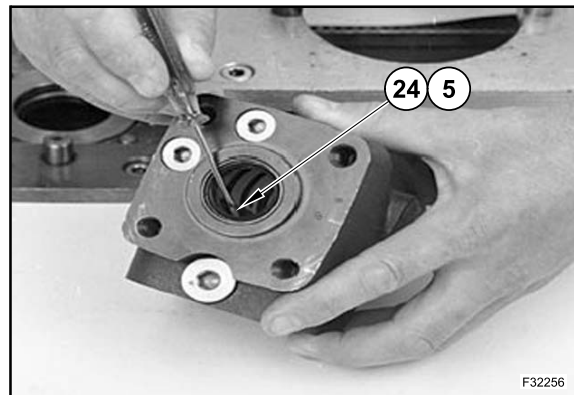

Remove plugs from shock valves using a 6 mm hexagon socket spanner.

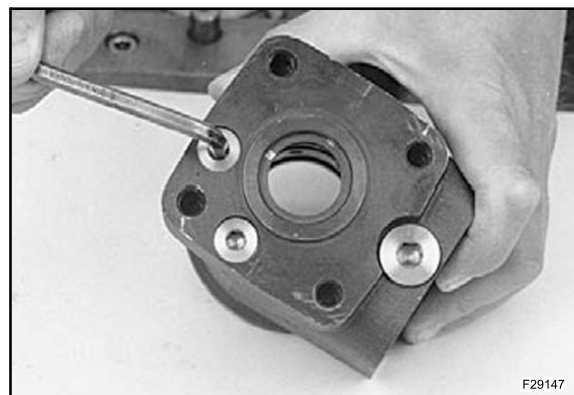

Fit the gearwheel (rotor) and cardan shaft so that a tooth base in the rotor is positioned in relation to the shaft slot. Turn the gear rim so that the seven through holes match the holes in the housing.

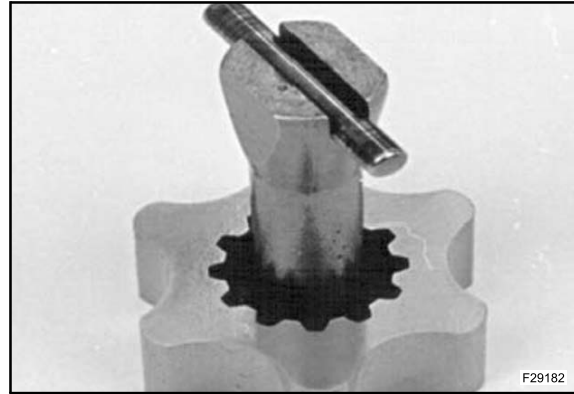

For precise keying and alignment of steering control valve, pay attention to the parallelism of (A), (B), (C) and (D) reference marks.

- A. Stator surface
- B. Plate surface
- C. Pin axis
- D. Power steering body surface
- E. Rotor surface
- F. Cardan shaft

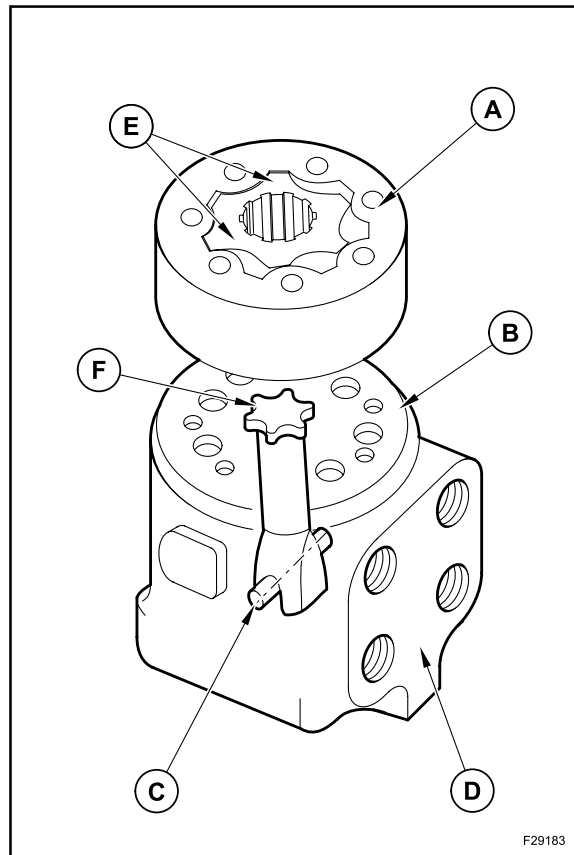

Place the end cover (15) in position.

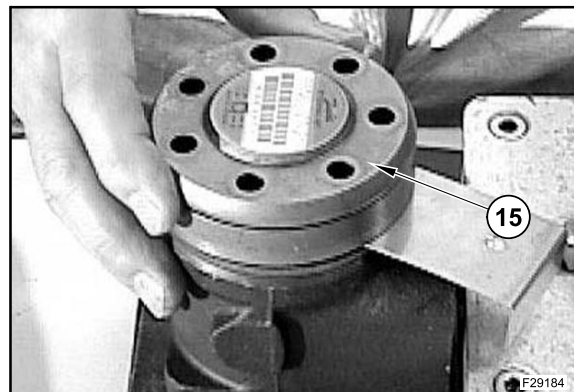

321E

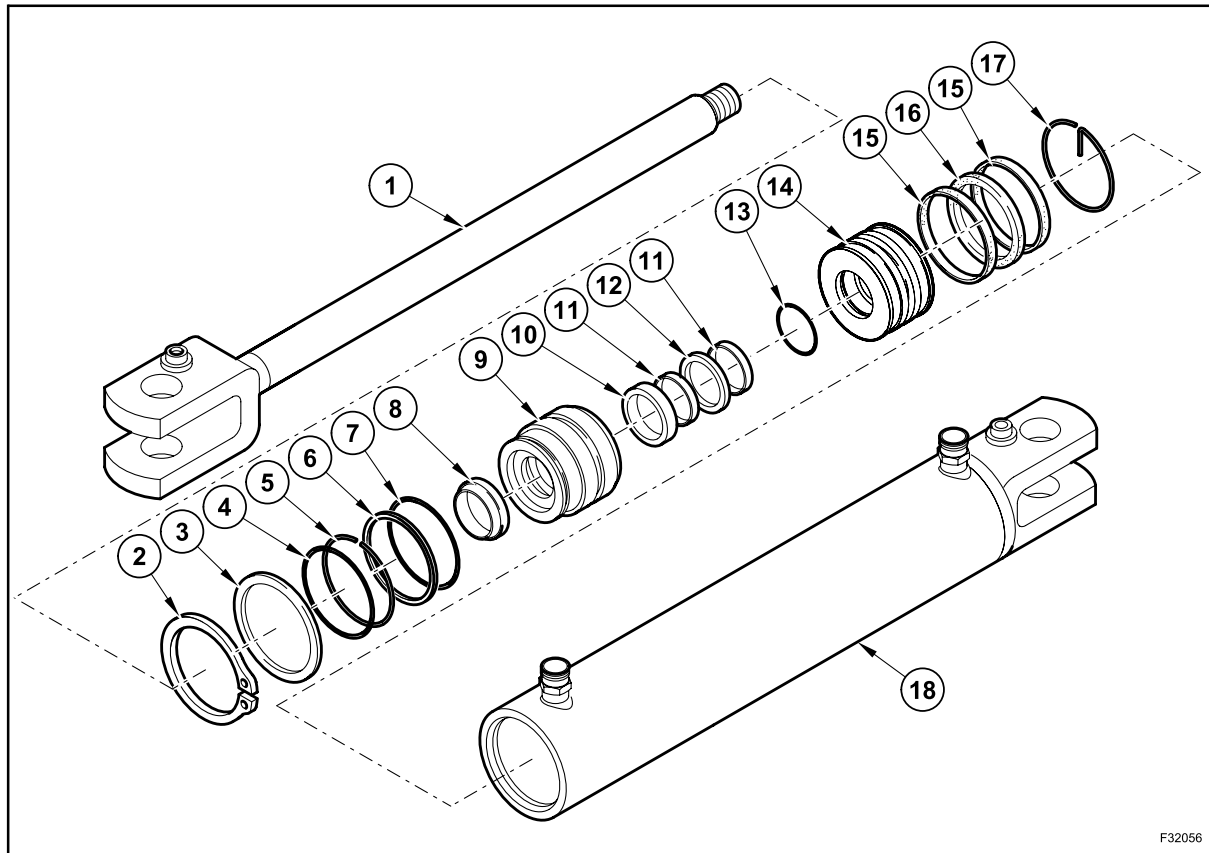

F32056

- |                  |                       |
|------------------|-----------------------|
| 1. Rod           | 10. Seal ring         |
| 2. Snap ring     | 11. Guide bushing     |
| 3. Washer        | 12. Seal ring         |
| 4. Ring          | 13. O-ring            |
| 5. Safety ring   | 14. Piston            |
| 6. Back-up ring  | 15. Piston guide ring |
| 7. O-ring        | 16. Piston gasket     |
| 8. Wiper ring    | 17. Piston lock ring  |
| 9. Cylinder head | 18. Cylinder liner    |

- When a liquid is atomized through an orifice, the temperature of the resultant vapour will lower. The low temperature of the atomized liquid will then absorb heat from its surrounding. On air conditioning systems the coolant is atomized using an expansion valve.

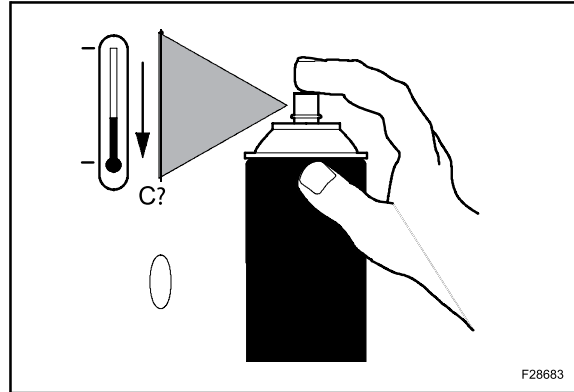

## 2.5 COMPONENTS OVERHAUL

### ⚠ WARNING

Before disconnecting components in the air conditioning system the coolant gas must be discharged and recovered using a certified recovery system. Refer to "Evacuating the system". **Do Not** discharge the gas into the atmosphere.

If an air conditioning component is to be replaced during a system overhaul it is necessary to drain any cooling oil that has collected in the component being replaced into a clean calibrated container.

A volume of clean coolant equivalent to that removed from the replaced component must then be added to the new item before being installed onto the machine.

Upon completion of the repair drain, recharge, leak test and performance test the system to ensure correct operation.

### Evaporator

- Discharge and reclaim coolant gas using certified recovery systems.
- Remove the seat and the panel (2) to make evaporator assy (1) accessible.
- Remove temperature cycling control thermocouple.
- Disconnect tubing to valve (3).
- Remove the evaporator (1).
- Check evaporator fins for damage. Straighten fins if necessary.
- Clean the evaporator core from all foreign materials and make sure it is free from obstructions.
- Check that evaporator (1) is not leaking any coolant. If damage or leaks are evident, replace the evaporator core.

If a new evaporator is to be installed, drain the cooling oil inside of it into a clean calibrated container. Measure the quantity of oil obtained and add the same quantity of clean cooling oil directly into the new evaporator core.

Reassemble the evaporator by following the disassembly procedure in reverse sequence.

Drain, leak test and recharge the system.

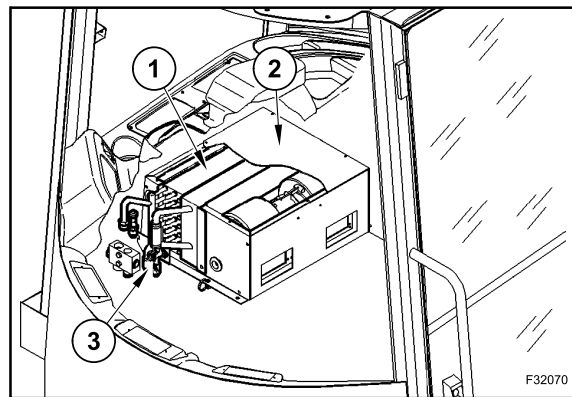

Install the field coil snap ring (9).

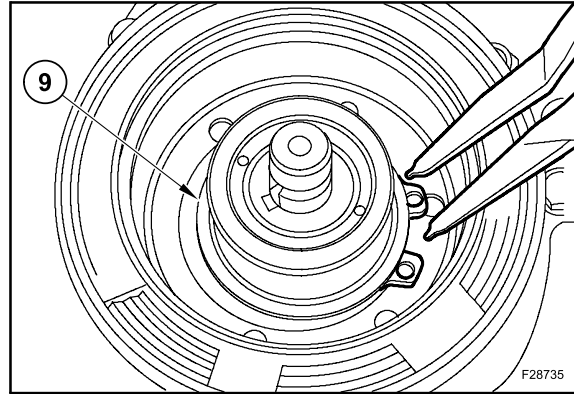

Position the pulley assy (8) on the housing hub and carefully slide the pulley (8) down the shaft.

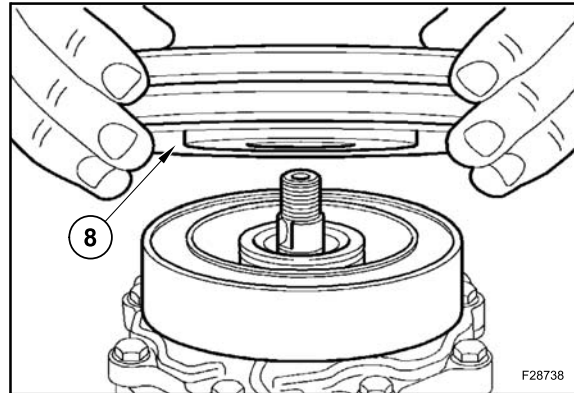

Install the snap ring (7).

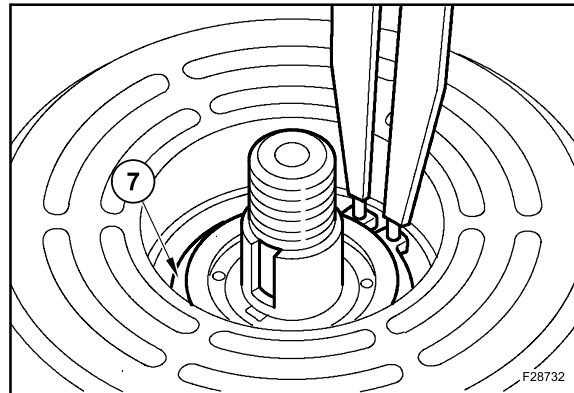

Install the cover (6). Fit the key (11) on shaft. Fit the shims (5).

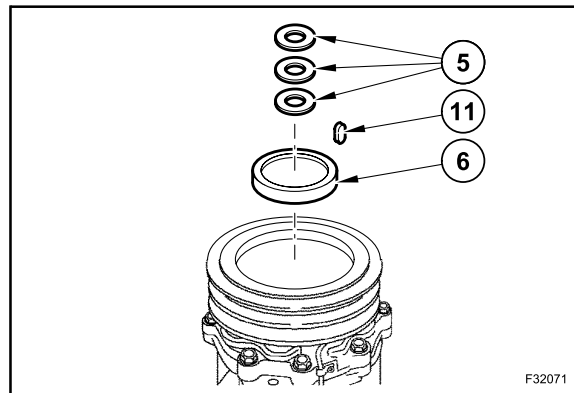

**NOTES:**

LIGHTS

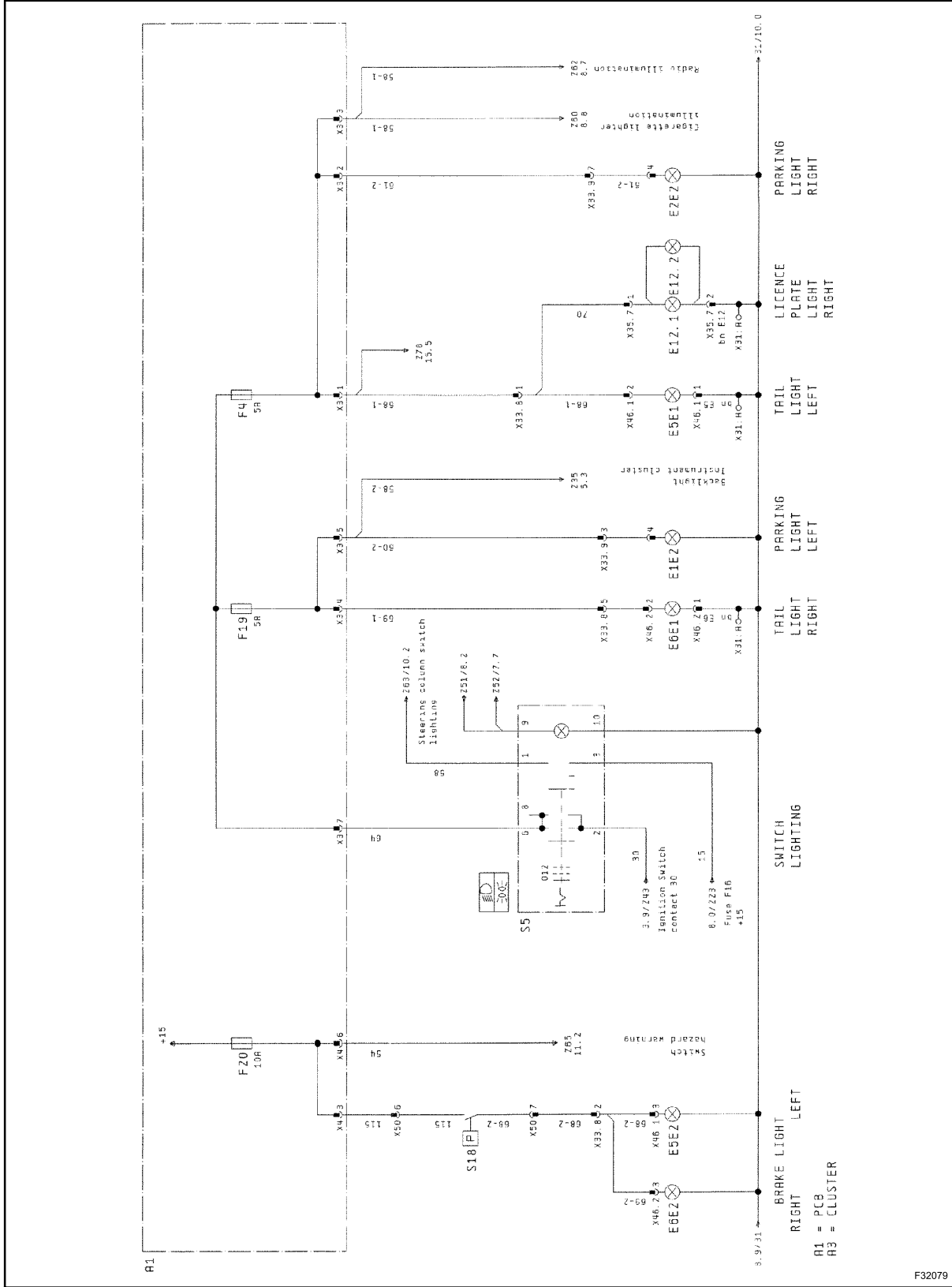

### 3. VOLTAGE AND CONTINUITY CHECK

Prior to working on the electrical system, where tools, spare parts etc. may come into contact with electric cables or contacts, disconnect the battery. Disconnect first the negative, then the positive clamp.

After work, connect first the positive clamp then the negative.

Use only measuring instrument for voltage and continuity testing:

- never use a test lamps;
- never tap against ground.

This causes a short circuit with consequent damage to the alternator or to the electronics of PMS.

To start up the engine, the alternator is controlled (pre-excited) by an electronic circuit, whose task consists in enabling the alternator to supply power.

The circuit is an integral part of the central electronic system in the control console.

A warning lamp in the control console (alternator) indicates that the alternator is functioning correctly. This LED must light up when the key switch is switched on; it is extinguished when the engine is running.

If this is not the case, there is a fault in the alternator circuit or in the control console.

To prevent further damage, the cause of the fault must be traced and eliminated as quickly as possible.

Address to After-sales Service.

---

*SECTION 82 - WORKING EQUIPMENT*

---

---

## 5. BUCKET

		21E			121E		221E		321E		
SAE capacity	m <sup>3</sup> (ft <sup>3</sup> )	0.65 (23)	0.70 (24.7)	0.80 (28.2)	0.80 (28.2)	0.90 (31.8)	0.90 (31.8)	1.00 (35.3)	1.00 (35.3)	1.10 (38.8)	1.20 (42.4)
Width	mm (ft)	1800 (5.9)	1900 (6.2)	1900 (6.2)	2050 (6.7)	2050 (6.7)	2050 (6.7)	2100 (6.900)	2100 (6.9)	2100 (6.9)	2100 (6.9)
Weight	kg (lb)	250 (551)	265 (584)	295 (650)	315 (694)	335 (738)	335 (738)	365 (805)	365 (805)	370 (816)	410 (904)

### ASSEMBLY

The bucket lays upright on the ground.  
By moving the machine forward, bring the lifting frame (1) and the bucket (2) to assembly position.

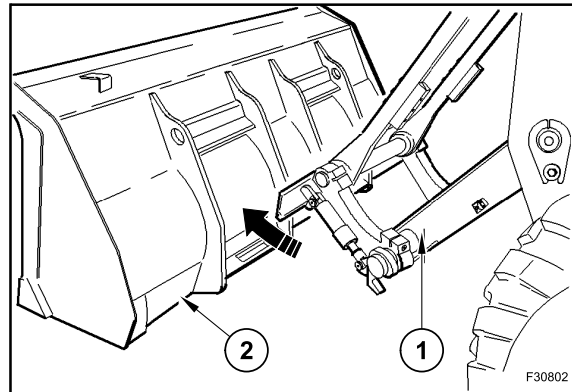

Unlock the switch (3) from mechanical lock and press the symbol face of switch (lamp on).

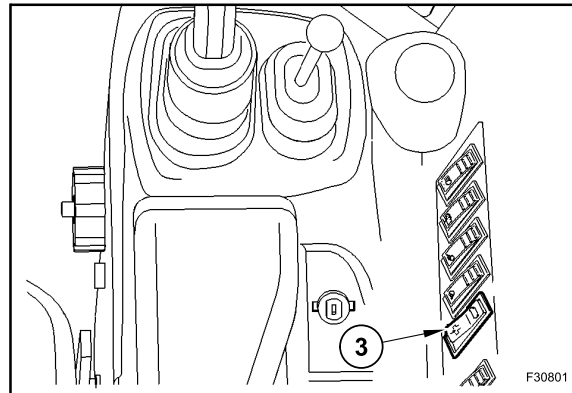

Move the wheel loader until the upper support (4) of the lifting frame can fit into the bucket housing (5). Lift the bucket and tip it back to enable the support to fit into the housing (5).

Set switch (3) to LOCKED position (lamp off). The lower hook (7) fits into the housing (6). The bucket is now locked (3) (lamp off).

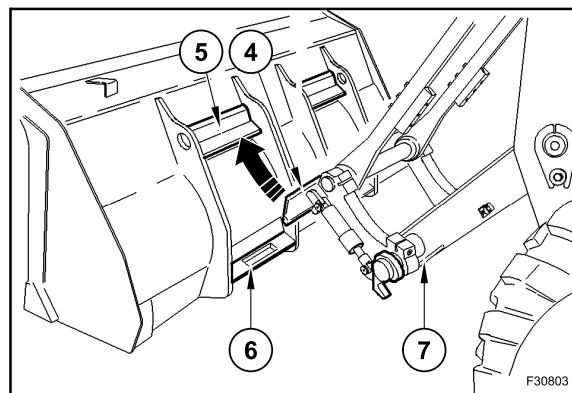

## DISASSEMBLY

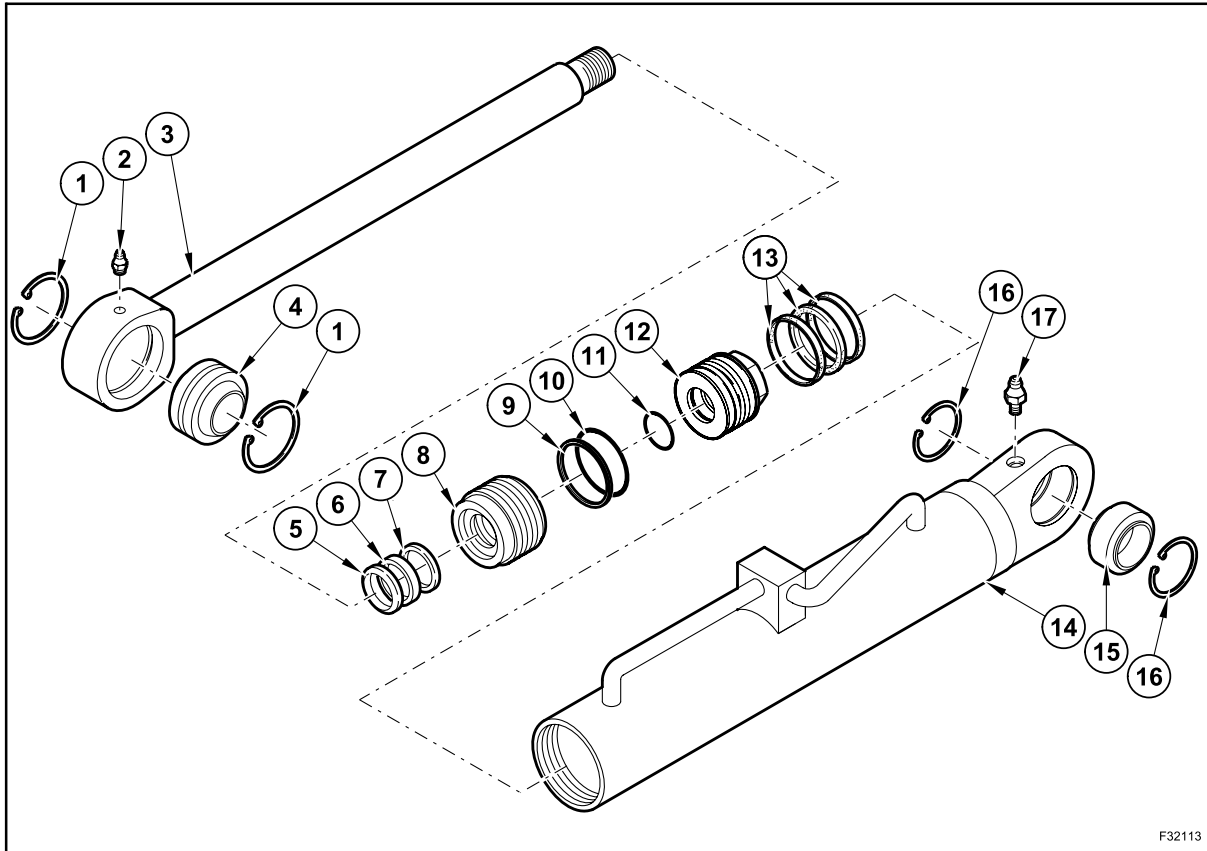

F32113

- |                  |                    |
|------------------|--------------------|
| 1. Snap ring     | 10. O-ring         |
| 2. Grease nipple | 11. O-ring         |
| 3. Rod           | 12. Piston         |
| 4. Hinge bushing | 13. Piston gasket  |
| 5. Wiper ring    | 14. Cylinder liner |
| 6. Seal ring     | 15. Hinge bushing  |
| 7. Seal ring     | 16. Snap ring      |
| 8. Cylinder head | 17. Grease nipple  |
| 9. Back-up ring  |                    |

The disassembly procedure that follows takes into consideration the hydraulic pipings already disassembled.

Lift and place the cylinder on a workbench and secure it. Be sure that the cylinder is placed horizontally. Drain hydraulic oil from cylinder.

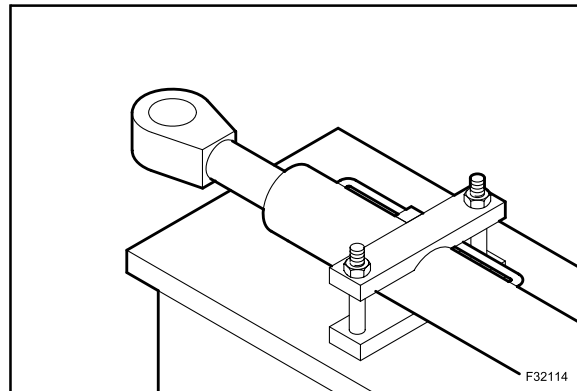

F32114

CLICK HERE TO **DOWNLOAD** THE COMPLETE MANUAL

- Thank you very much for reading the preview of the manual.
- You can download the complete manual from: [www.heydownloads.com](http://www.heydownloads.com) by clicking the link below



- Please note: If there is no response to CLICKING the link, please download this PDF first and then click on it.

CLICK HERE TO **DOWNLOAD** THE COMPLETE MANUAL