

**Repair Manuals for other
Briggs & Stratton Engines:**

- 273521 Twin Cylinder OHV Air-Cooled Engines
- 271172 Twin Cylinder L-Head Air-Cooled Engines
- 270962 Single Cylinder L-Head Air-Cooled Engines
- 276535 Two-Cycle Snow Engines
- CE8069 Out of Production Engines (1919-1981)



Briggs & Stratton



**Single Cylinder OHV
Air-Cooled Engines**



Quality Starts With A
Master Service Technician



Equipment & Engine
Training Council



The Power Portal

www.ThePowerPortal.com (Dealers)

BRIGGSandSTRATTON.COM (Consumers)



0 24847 37833 7

Part No. 276781-8/09

**BRIGGS&STRATTON
CORPORATION**

POST OFFICE BOX 702
MILWAUKEE, WI 53201 USA
©2009 Briggs & Stratton Corporation

8/09

SINGLE CYLINDER OHV AIR-COOLED ENGINES



CLICK HERE TO **DOWNLOAD** THE COMPLETE MANUAL

- Thank you very much for reading the preview of the manual.
- You can download the complete manual from: www.heydownloads.com by clicking the link below



- Please note: If there is no response to CLICKING the link, please download this PDF first and then click on it.

CLICK HERE TO **DOWNLOAD** THE COMPLETE MANUAL

ENGINE MAINTENANCE

Fuel and Oil Recommendations

Fuel must meet these requirements:

- Clean, fresh, unleaded gasoline.
- A minimum of 87 octane / 87 AKI (90 RON).
- Gasoline with up to 10% ethanol (gasahol) or up to 15% MTBE (methyl tertiary butyl ether) is acceptable.
- **NOTICE:** Do not use unapproved gasoline, such as E85. Do not mix oil in gasoline or modify the engine to run on alternate fuels. This will damage the engine components and **void the engine warranty.**

To protect the fuel system from gum formation, mix a fuel stabilizer into the fuel. All fuel is not the same. If starting or performance problems occur, change fuel providers or change brands. This engine is certified to operate on gasoline. The emissions control system for this engine is EM (Engine Modifications).

High Altitude

At altitudes over 5,000 feet (1524 meters), a minimum 85 octane / 85 AKI (89 RON) gasoline is acceptable. To remain emissions compliant, high altitude adjustment is required. Operation without this adjustment will cause decreased performance, increased fuel consumption, and increased emissions.

Operation of the engine at altitudes below 2,500 feet (762 meters) with the high altitude kit is not recommended.

Fresh Start® Fuel Cap

Some engines are equipped with a Fresh Start® fuel cap. The Fresh Start fuel cap is designed to hold a cartridge (sold separately) that contains fuel stabilizer.

Oil must meet these requirements:

- Briggs & Stratton Warranty Certified oils are recommended for best performance.
- Other high-quality detergent oils are acceptable if classified for service SF, SG, SH, SJ or higher.
- Do not use special additives.

Outdoor temperatures determine the proper oil viscosity for the engine. Use the chart (Figure 1) to select the best viscosity for the outdoor temperature range expected.

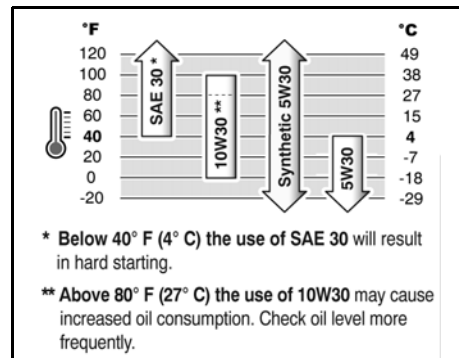

Figure 1

Governor Adjustments

A complete governor system adjustment includes a static adjustment, engine warm-up, idle and/or governed idle adjustment, and top no-load adjustment. Be sure to complete all steps.

Static Adjustment

1. Loosen screw holding governor lever to governor crank (A, Figure 28) or (C, Figure 29).
2. Rotate throttle linkage from idle position to wide open throttle. Note direction of rotation of the governor arm attached to the throttle linkage.
3. While holding linkage at wide open throttle, use the appropriate tool to rotate the governor shaft (B, Figure 29) until it stops in the direction noted in Step 2.
4. Tighten screw holding governor lever to governor crank per Section 12 - Engine Specifications.
5. Before starting engine, manually actuate throttle linkage to check for binding.

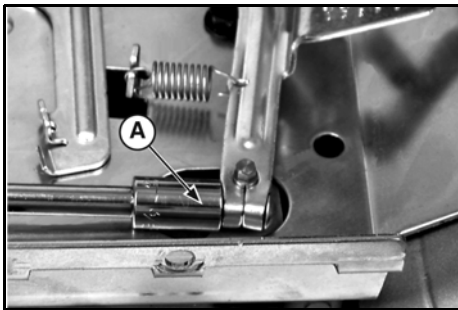

Figure 28

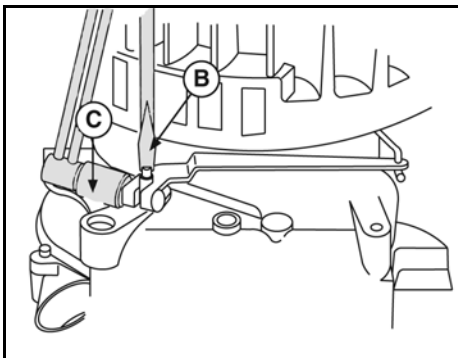

Figure 29

Top No Load Adjustment Vertical Models 97700, 99700

1. Place throttle (A, Figure 30 and 31) in FAST position and insert a 1/8" (3.2 mm) rod (B) through holes in carburetor control bracket and lever.

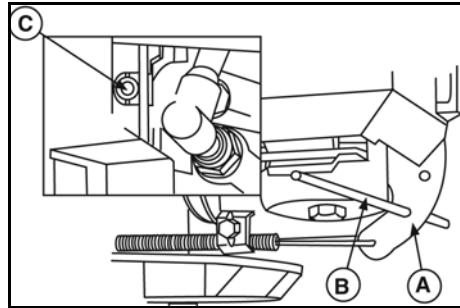

Figure 30

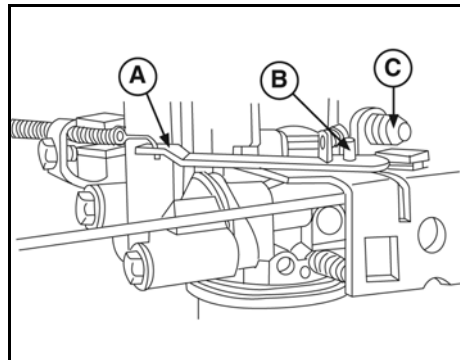

Figure 31

2. Start engine and measure RPM using Tachometer #19200 or #19389. Adjust Top No Load RPM by turning screw (C).
3. Remove 1/8" (3.2 mm) rod.

NOTE: Correct Top No Load RPM for each model-type-trim can be found in the engine replacement data on Briggs & Stratton websites.

ELECTRICAL SYSTEMS

Equipment Used for Testing

Digital Multimeter

A digital multimeter is recommended for all electrical testing of Briggs & Stratton engines. The meter can be used to read volts, ohms, amperes, and to test diodes.

The Fluke® Digital Multimeter #19464 and the UNI-T® Digital Multimeter #19581 are available from your Briggs & Stratton source of supply.

NOTICE: The digital multimeters are equipped with fuses to prevent damage to the meter if the input limits are exceeded. Check the fuses if the meter displays a reading of **0.00** when testing DC Volts output.

Refer to the Fluke® Operator's Manual for this procedure. Replacement fuses #19449 for Series II meters or #19571 for Series III meters are available from your Briggs & Stratton source of supply.

The UNI-T® Operator's Manual lists the fuse replacement procedure and type of replacement fuses required.

DC Shunt

The Fluke® meter will withstand DC input of 10-20 amps for up to 30 seconds.

The UNI-T® meter will withstand DC input of 10 amps for up to 10 seconds.

When checking DC output on 10 and 16 amp regulated systems, the DC Shunt #19468 (Figure 5) is required to avoid blowing a fuse in either of the meters.

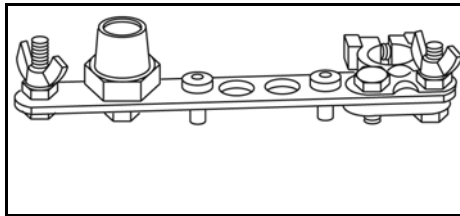

Figure 5

Tachometer

Tachometers #19200 (A) or #19389 (B, Figure 6) are available from your Briggs & Stratton source of supply.

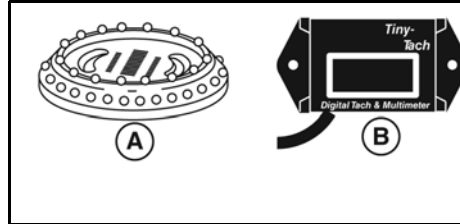

Figure 6

Starter Motor Test Fixture

A starter motor test fixture may be made from 1/4" (6mm) steel stock (Figure 7).

1. Extra hole for mounting starter brackets (A).
2. Drill two 3/8" (10mm) holes for starter mounting bracket (B).
3. Drill two holes for mounting Tachometer #19200. Drill and tap the holes for 1/4-20 NC screws (C).

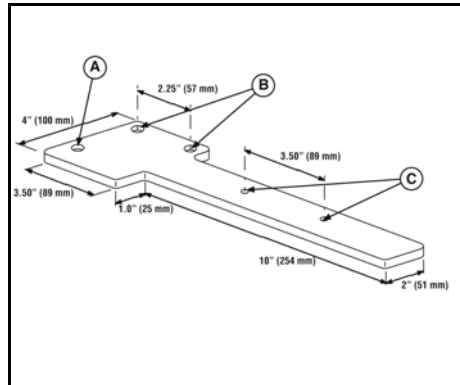

Figure 7

Other Equipment

A growler or armature tester (checks armature for continuity, shorts, and opens) is available from an Automobile Diagnostic Service supplier.

Also, a known good 12 Volt battery is required when testing starting systems or alternators.

2. Insert BLACK test lead (B) into the COM receptacle in the meter.
3. Attach RED test lead clip to (D) of the WHITE wire (C). (It may be necessary to pierce wire with a pin as shown.)
4. Insert BLACK test lead (B) into harness connector.

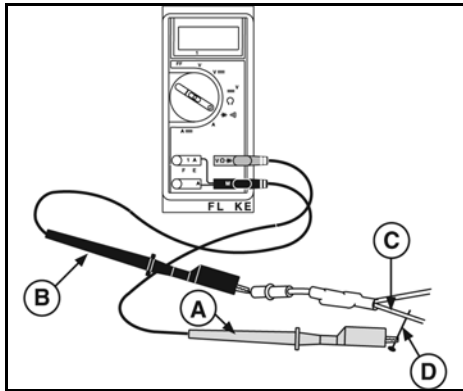

Figure 25

- If meter “Beeps” once, diode is OK.
 - If meter makes a continuous tone, diode is defective (shorted).
 - If meter displays “OL,” proceed to Step 4.
5. Reverse test leads.
 - If meter “Beeps” once, diode is installed backwards.
 - If meter still displays “OL,” diode is defective (open).
 6. If diode tests OK, replace stator.

5 & 9 Amp DC Regulated Alternator

The 5 & 9 Amp regulated alternator systems provide AC current through a single lead into the regulator-rectifier. The regulator-rectifier converts the AC current to DC and regulates current to the battery. The charging rate will vary with engine RPM and temperature.

Alternator output is determined by the flywheel alternator magnet size. The stator and regulator-rectifier are the same for the 5 & 9 Amp regulated system and the Tri-Circuit System.

Test Alternator Output

1. Temporarily disconnect stator wire harness from the regulator-rectifier.
2. Insert RED test lead (A, Figure 26) into the V Ω receptacle in the meter.
3. Insert BLACK test lead (B) into COM receptacle.
4. Rotate selector to AC Volts position.
5. Attach RED test lead clip to GREEN output terminal (C).
6. Attach BLACK test lead clip to engine ground.

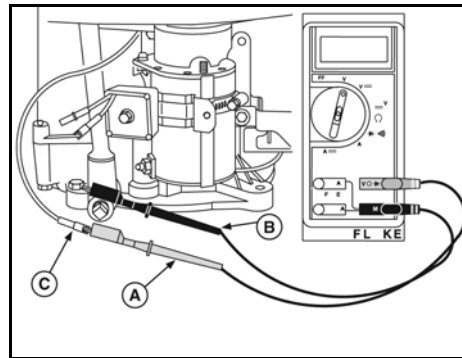

Figure 26

7. With engine running at 3600 RPM, AC output should be no less than:
 - 28 Volts AC - 5 Amp System
 - 40 Volts AC - 9 Amp System
8. If NO or LOW output is found, replace the stator.

Test Regulator-Rectifier

NOTE: The regulator-rectifier will not function unless it is grounded to engine. Make sure the regulator-rectifier is securely mounted to the engine. When testing regulator-rectifier amperage output, a 12 Volt battery with a minimum charge of 5 Volts is required. There will be no output if battery voltage is below 5 Volts.

NOTICE: Connect test leads BEFORE starting the engine. Be sure connections are secure. If a test lead vibrates loose while engine is running, the regulator-rectifier may be damaged.

2

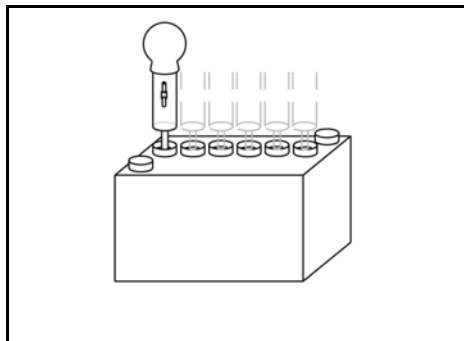

Figure 40

Testing Battery

Set the digital multimeter to DC volts position.
Test the battery while installed in the equipment.

1. Disconnect wire from spark plug and ground ignition using Ignition Tester #19368.
2. Attach RED meter test clip to positive (+) battery terminal. Attach BLACK meter test lead to negative (-) battery terminal.
3. Turn switch to START. Meter should display 9 volts or more while cranking engine. If less than 9 volts, replace battery.

NOTICE: To prevent damage to the starter motor, do not crank starter for more than 15 seconds without allowing starter to cool at least 2 minutes.

7. Install blower housing and rewind starter.
8. Install oil fill tube and dipstick.
9. Lightly coat muffler guard mounting screws with Valve Guide Lubricant #93963.
10. Place muffler guard over muffler and start screws (A, B, C, Figure 22). Torque to values listed in Section 12 - Engine Specifications.

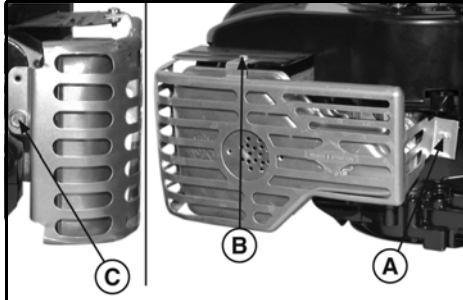

Figure 22

Vertical Models 210000, 280000, 310000, 330000 with Clamped Muffler

Shown is a typical muffler application (Figure 23).

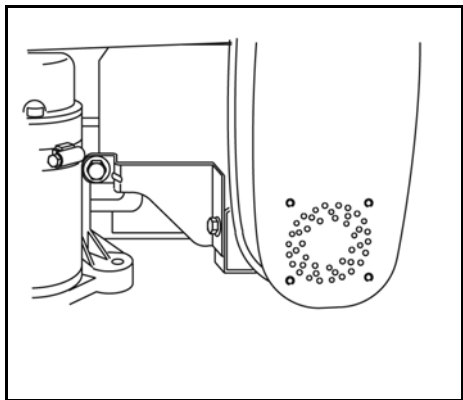

Figure 23

Remove Muffler

1. Remove muffler brace screws (A, B, C, Figure 24) and supports.
2. Loosen muffler clamp (D) and slide muffler off adapter.

3. Remove adapter screws, adapter, and gaskets. Discard gaskets.

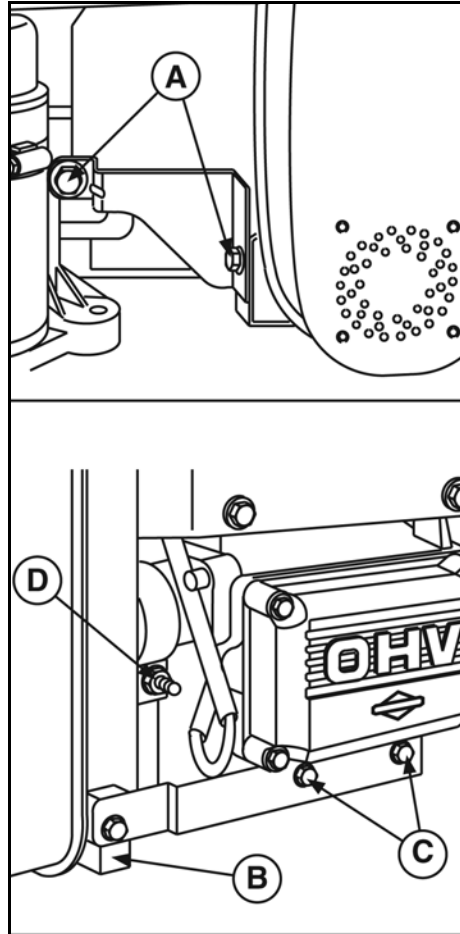

Figure 24

Inspect Exhaust System

All exhaust system components must be inspected whenever the exhaust system is disassembled. Check muffler mounting bracket and/or muffler adapters for cracked welds or breakage. Check muffler for split seams, loose internal parts, or cracked welds. Replace any damaged parts with new OEM parts.

Never reinstall broken or damaged components.

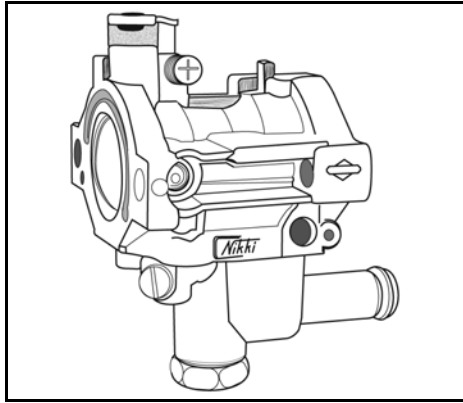



Figure 11

4

	WARNING
<p>Before servicing the carburetor or other fuel system components, drain all fuel from the tank and turn OFF the fuel valve (if equipped). Do not attempt to stop fuel flow by plugging the fuel hose.</p>	

NOTE: Consult the Illustrated Parts List to obtain the appropriate carburetor overhaul kit before reassembling the carburetor.

NOTE: Many early carburetors had adjustable needle valves to compensate for high altitude conditions. Later carburetors use replaceable main jets to compensate for various high altitude ranges. See the appropriate Illustrated Parts List for replacement needle valves or jets.

Carburetor Service

LMS Carburetor

Vertical Models 97700, 99700, 110000, 120000

The exact type of LMS carburetor can be identified by a number stamped on the edge of the mounting flange (A, Figure 12). These carburetors have a fixed high-speed main jet and a non-adjustable idle mixture (except on early production models), and are available in manual/remote choke or Choke-a-Matic® versions.

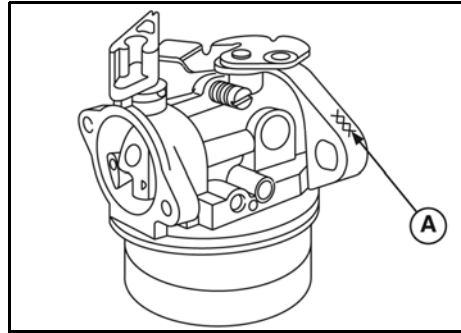



Figure 12

Remove Carburetor

	WARNING
<p>Before servicing the carburetor or other fuel system components, drain all fuel from the tank and turn OFF the fuel valve (if equipped). Do not attempt to stop fuel flow by plugging the fuel hose.</p>	

1. Remove air cleaner assembly per Section 1. Discard the gasket.
2. Move clamp and disconnect fuel hose from carburetor.
3. Disconnect the Choke-a-Matic® spring, if equipped, from choke lever (A, Figure 13, Figure 14).

CLICK HERE TO **DOWNLOAD** THE COMPLETE MANUAL

- Thank you very much for reading the preview of the manual.
- You can download the complete manual from: www.heydownloads.com by clicking the link below



- Please note: If there is no response to CLICKING the link, please download this PDF first and then click on it.

CLICK HERE TO **DOWNLOAD** THE COMPLETE MANUAL

Remove Carburetor

1. Disconnect wire(s) from the carburetor solenoid. Two styles of solenoids have been used (Figure 42).

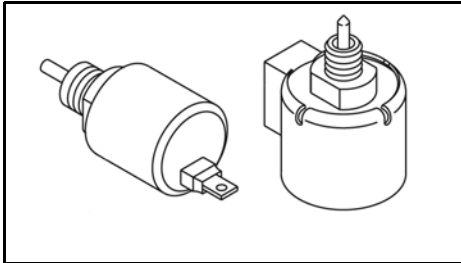

Figure 42

2. Remove air cleaner assembly per Section 1. Discard the gasket.
3. Move clamp and disconnect hose from carburetor.
4. Remove two carburetor screws or nuts while holding carburetor.
5. Carefully rotate carburetor to disconnect throttle (A, Figure 43) and spring (B) and the choke link during removal.

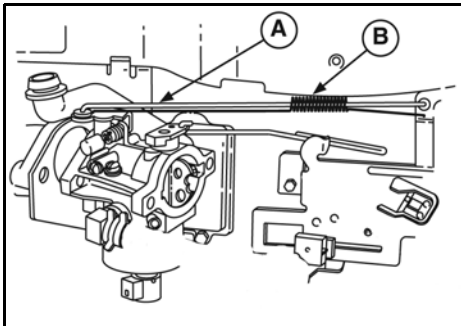

Figure 43

Disassemble Carburetor

1. Remove solenoid and solenoid washer. Discard washer. Remove float bowl and float bowl gasket from carburetor. Discard gasket.
2. Using Carburetor Nozzle Screwdriver #19280, remove the main carburetor emulsion tube (A, Figure 44).

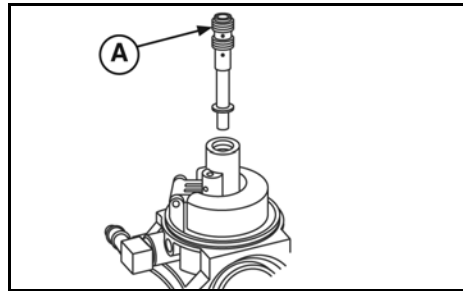

Figure 44

3. Remove float hinge pin, float, and inlet needle. Discard the hinge pin and inlet needle.
4. Screw a 1/4-20 tap into fuel inlet seat 3-4 turns and remove.
5. Place a hex nut (A, Figure 45) and washer (B) on a 1/4-20 screw. Place 1/4" drive 3/8" socket (C) over fuel inlet seat.
6. Thread screw into tapped inlet seat until screw bottoms. Thread nut down to washer and continue turning nut until inlet seat is free from carburetor body.

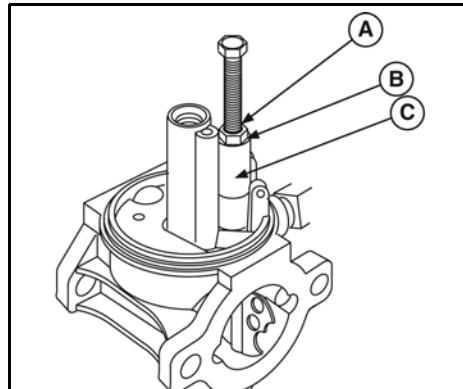

Figure 45

7. Remove idle mixture limiter cap, when used, then remove idle mixture screw with spring and idle speed screw with spring.
8. Rotate throttle shaft to closed position and remove throttle valve screws and throttle valve.
9. Remove throttle shaft, foam seal, and throttle shaft seal from carburetor body. Discard seals.
10. If carburetor is equipped with a plastic choke shaft, rotate choke shaft to wide

GOVERNOR SYSTEMS

Linkage and Spring Orientation

NOTE: Be sure to note hole position of linkage before removing.

- Figure 1 - Horizontal Shaft Models 110000, 120000, 150000, 200000, 210000.
- Figure 2 - Vertical Shaft Model 97700
- Figure 3 - Vertical Shaft Model 99700
- Figure 4 - Vertical Shaft Models 110000, 120000, 210000 (Primer Carburetors).
- Figure 5 - Vertical Shaft Models 110000, 120000, 210000 (Choke-A-Matic® Carburetors).
- Figure 6 - Models 280000, 310000, 330000 (Choke-A-Matic® Carburetors).
- Figure 7 - Models 280000, 310000, 330000 (Manual Friction).
- Figure 8 - Models 280000, 310000, 330000 (Manual Choke).

5

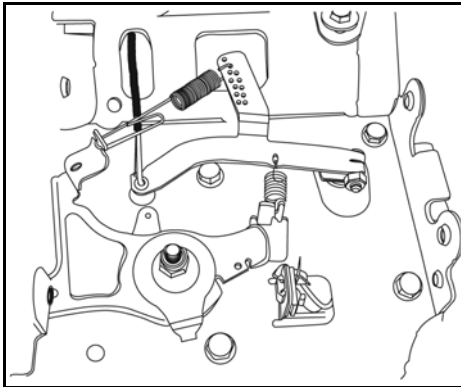

Figure 1

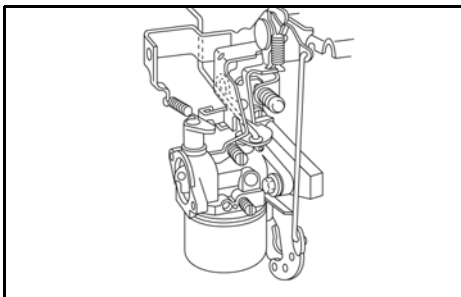

Figure 2

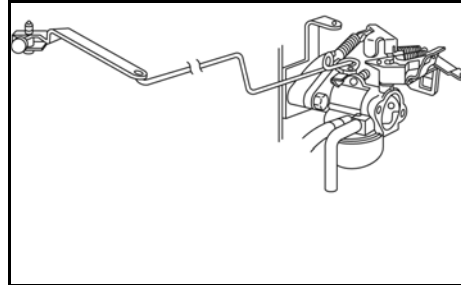

Figure 3

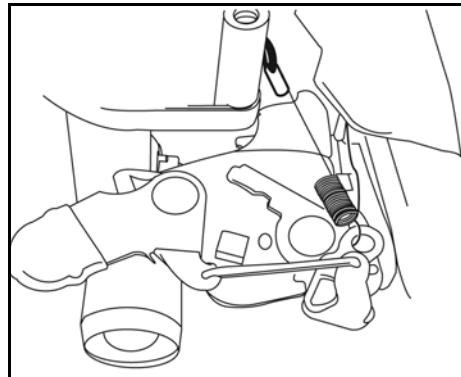

Figure 4

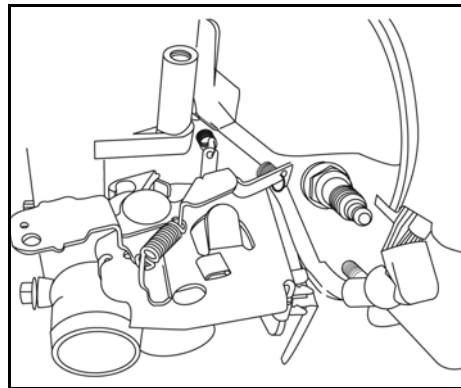

Figure 5

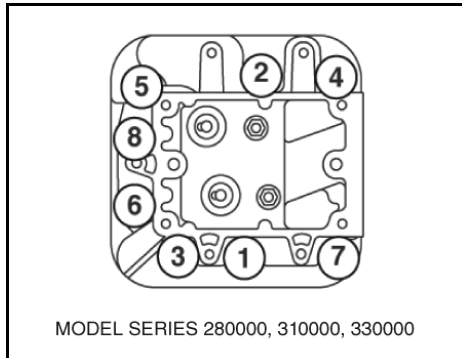

Figure 18

NOTE: Do not torque each screw in one step as it may result in a warped cylinder head. Step-torque all screws to approximately 1/3 of final torque value, then to 2/3 final torque value, then finish at final torque value.

3. Install push rod guide and rocker arm studs (models 97700, 99700). Torque studs to values listed in Section 12 - Engine Specifications.

-OR-

4. Install rocker arm studs (models 110000, 120000, 150000). Torque to values listed in Section 12 - Engine Specifications.

NOTE: Early production of vertical models 110000 and 120000 require a jam nut to be threaded approximately half way up the threads of the stud before installation into the head.

5. Install push rods through guides and into same positions as removed. Ensure rods are seated in valve tappets. Place valve stem caps (if used) on valve stems.
6. Place rocker arms and rocker balls on rocker arm studs (Figure 19). Install rocker arm screws and/or lock nuts on studs and tighten until there is zero clearance between the valve stem caps and the rocker arms.

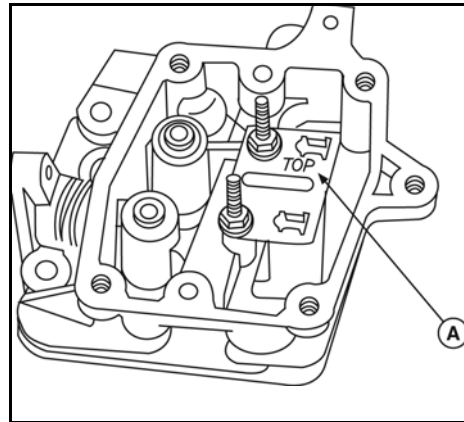

Figure 19

7. Rotate crankshaft at least twice to ensure proper movement of the push rods and rocker arms.
8. Adjust valve clearance per Section 1, then install a new rocker cover gasket and the rocker cover. Torque screws to values listed in Section 12 - Engine Specifications.

Vertical Models 97700, 99700

1. Install the screws to the blower housing (D, Figure 11), torquing screws to values listed in Section 12 - Engine Specifications.
2. Install the oil fill tube and dipstick (C).

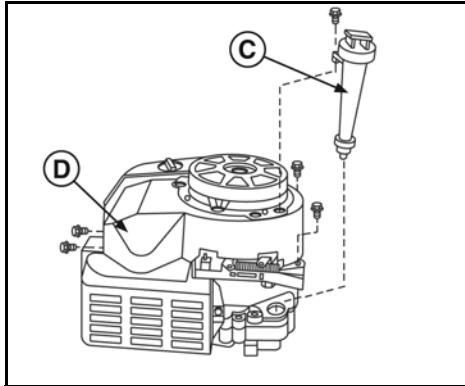

Figure 11

3. Install the screws to the finger guard (A, Figure 12) and the fuel tank (B), torquing screws to values listed in Section 12 - Engine Specifications.
4. Fill fuel tank or open fuel shut-off valve. Connect fuel hose to carburetor. Connect spark plug wire.

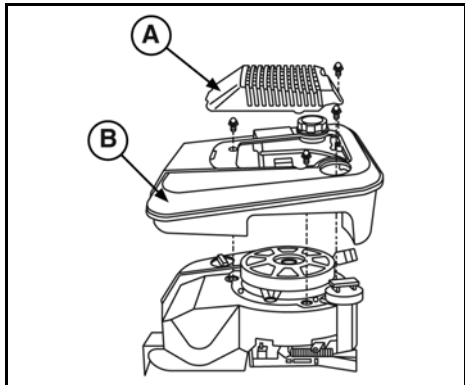

Figure 12

Vertical Models 110000, 120000

1. Install the oil fill tube and dipstick. Install the screws (F, Figure 13) and blower housing.

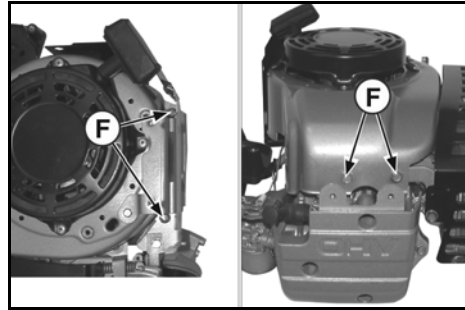

Figure 13

2. Install screws (D, Figure 14) and spacer (E), then install tank from engine. Torque screws to values listed in Section 12 - Engine Specifications.

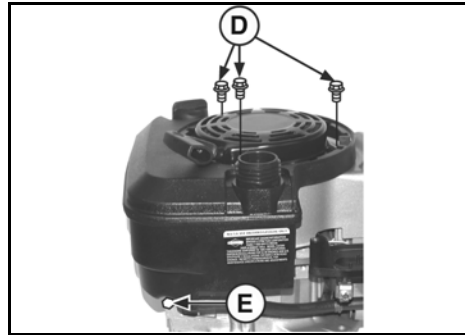

Figure 14

3. Install screws (B, Figure 15) to trim plate or (C) to rewind guard. Torque screws to values listed in Section 12 - Engine Specifications.

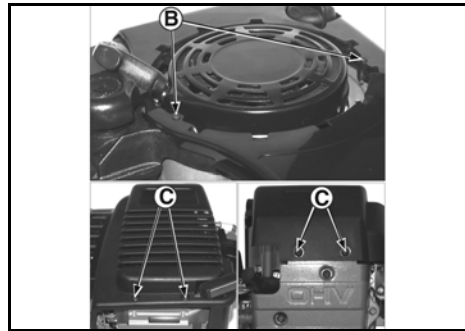

Figure 15

4. Install air cleaner cover. Press on tab (A, Figure 16) until finger guard attaches to engine.

NOTE: Do not apply force to the wire gauge! The disc valve is retained by an internal bracket which will be distorted if pressure is applied to disc.

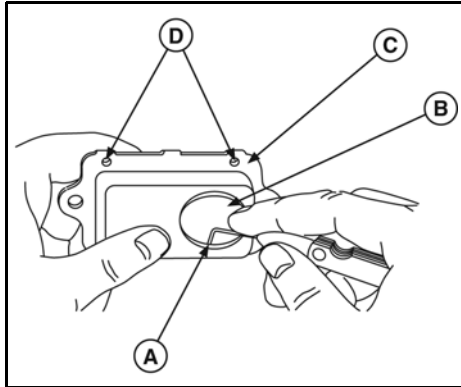

Figure 4

Install Breather

1. Place new gasket and breather assembly on cylinder. Torque to screws to values listed in Section 12 - Engine Specifications.
2. Securely insert breather tube into breather assembly.

Service Breather - Vertical Models 210000, 280000, 310000, 330000 Current Production

Remove Breather

1. Remove breather tube (B, Figure 5) from breather cover (A).

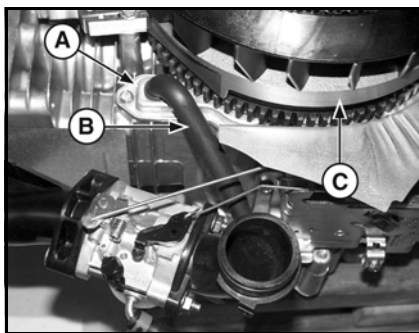

Figure 5

2. Remove two screws (B, Figure 6), breather cover. Discard gasket (before

date code 070719xx) or clean off sealant (after date code 070718xx).

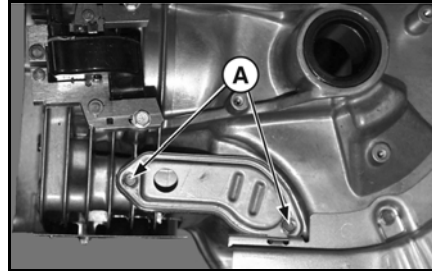

Figure 6

Check Breather

1. Remove and check breather reed (A, Figure 7). If the reed is worn or bent, it cannot function properly and must be replaced.

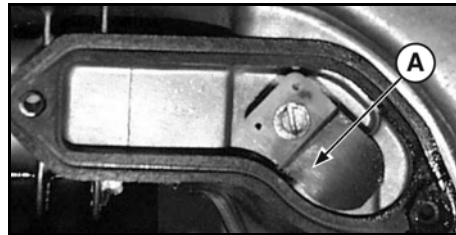

Figure 7

2. Inspect the oil drain-back hole (B, Figure 8). Insert a fine wire to ensure the opening is not plugged.

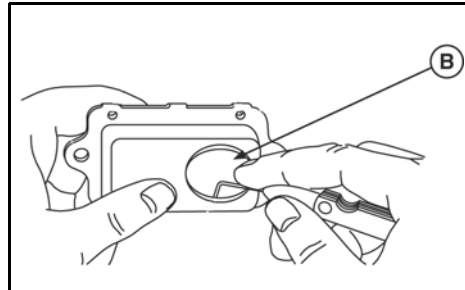

Figure 8

replace the affected cylinder, crankcase cover, or sump (Figure 6).

NOTE: Standard and reject sizes for the main bearings are shown in Section 12 - Engine Specifications.

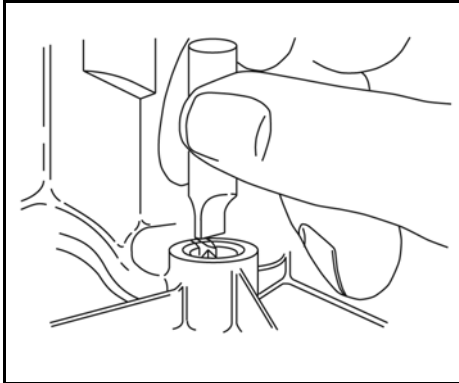

Figure 6

Replace Bearings

Replace DU™ Bearings

1. Select tools needed from Figure 7 and Figure 8.

Magneto Bearing Tools		
Model Series	Bushing Driver	Cylinder Support
110000 120000 All	19124	19123
150000 H/S	19124	19123
210000 H/S	19179	19227
210000 V/S	19450	19351
280000 V/S	19450	19227
310000 V/S	19450	19227
330000 V/S	19350	19351

Figure 7

PTO Bearing Tools		
Model Series	Bushing Driver	Cylinder Support
110000 120000 All	Replace Crankcase Cover or Sump	
150000 H/S	Replace Crankcase Cover	
210000 H/S	19179	19227
210000 V/S	Replace Sump	
280000 V/S	Replace Sump	
310000 V/S	Replace Sump	
330000 V/S	Replace Sump	

Figure 8

2. Remove and discard oil seal for bearing to be repaired.

NOTE: Before removing oil seal(s) note and record the depth of the oil seal from mounting surface so that the new seal is installed to the same depth.

3. Insert bushing driver tool (A, Figure 9) into bearing from oil seal side. Place a reference mark (B) on driver to indicate proper depth when installing the new bearing.

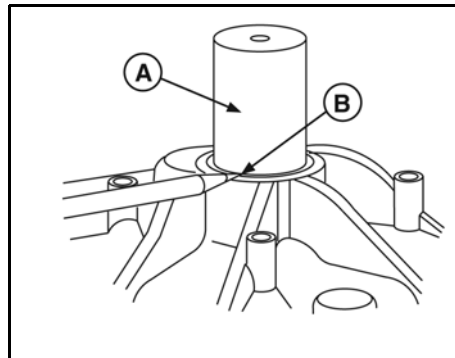

Figure 9

4. Place cylinder support tool (C, Figure 10) under cylinder or cover/sump bearing (B). Press driver until bearing is extracted.

Install Crankcase Cover or Sump

1. Using a new gasket install crankcase cover or sump using seal protectors. Do not force cover or sump on cylinder.

NOTE: It may be necessary to rotate crankshaft to get oil pump (if equipped) to engage drive slot in camshaft. For horizontal crankshafts, it may be necessary to rotate idler gear to mesh with timing gear when installing cover.

2. Install screws in sequence shown in Figures 9, 10, 11, and 12.
 - Figure 9 - Horizontal shaft models 120000, 150000, 200000, 210000
 - Figure 10 - Vertical shaft models 97700, 99700
 - Figure 11 - Vertical shaft models 120000, 210000
 - Figure 12 - Vertical shaft models 280000, 310000, 330000
3. Torque to values listed in Section 12 - Engine Specifications.

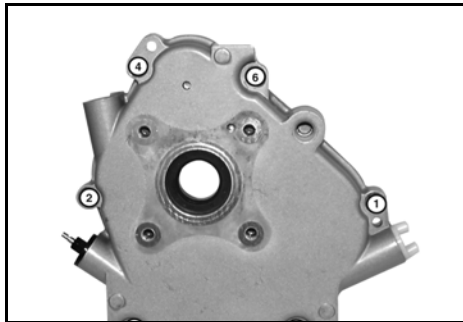

Figure 9

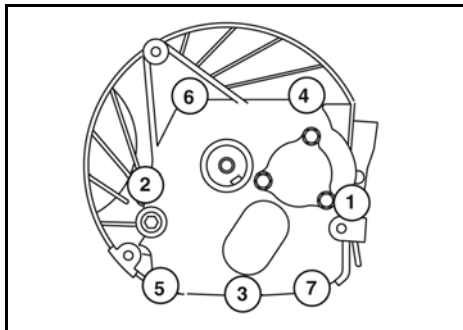

Figure 10

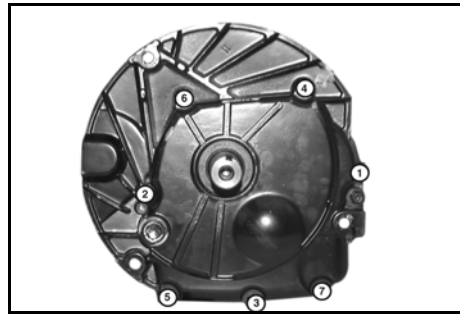

Figure 11

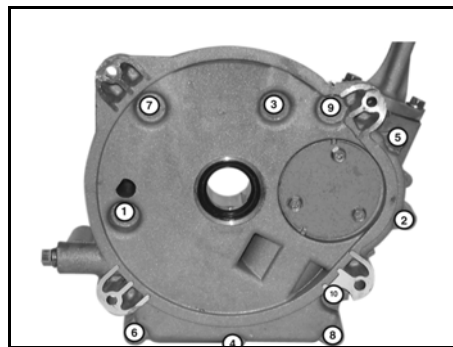

Figure 12

NOTE: Screws assembled at position 4, Figure 10 and position 9, Figure 12 were coated with sealant. If sealant is missing, coat with a non-hardening sealant such as Permatex® 2, or equivalent.

PISTONS, RINGS, & CONNECTING RODS

Remove Piston and Connecting Rod

1. Carefully remove any carbon or ridge at top of cylinder bore to prevent ring breakage.
2. Remove rod bolts and connecting rod cap (A, Figure 1).
3. Push piston and rod assembly out through top of cylinder bore.

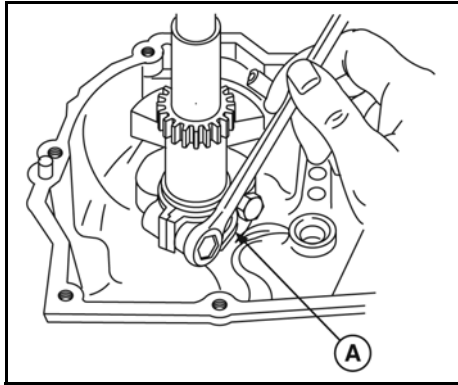

Figure 1

Disassemble

1. Rotate pin retainer until one end is exposed in notch in pin bore.
2. Remove the two retainer pins (A, Figure 2) with needle nose pliers.

NOTE: Some pistons have a shoulder stop on one side and a single retainer.

3. Slide out pin (B) from opposite side and remove connecting rod from piston.

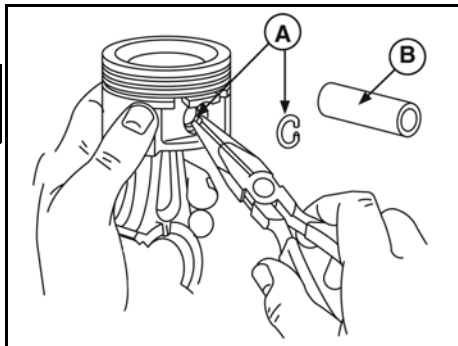

Figure 2

4. Using Piston Ring Expander #19340 (Figure 3), remove rings one at a time. Note the order and orientation of the rings before removal.

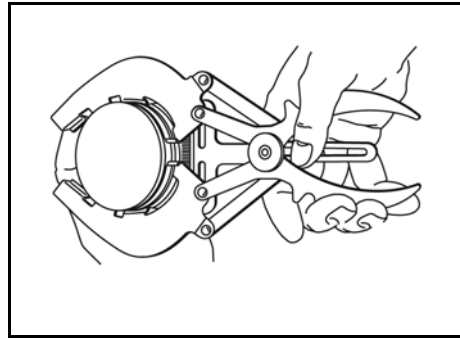

Figure 3

NOTE: Some oil control rings consist of two thin steel rails and a spring expander. These must be removed by hand as follows:

- Grasp one end of the upper steel rail and wind the rail from the oil ring groove into the center ring groove. Repeat into the top ring groove and then off the piston.
- Remove the spring expander, then remove the lower steel rail.

Inspect

Check Piston and Pin

1. Inspect piston for scoring, galling, or other damage. Replace piston if necessary.
2. Using a dial caliper or plug gauge, measure the pin bore diameter. Compare with reject dimensions listed in Section 12 - Engine Specifications. If pin bore exceeds reject dimensions, replace the piston.
3. Measure outside diameter of pin and compare to the reject dimension listed in Section 12 - Engine Specifications. If pin is smaller than the reject dimension, replace the pin.
4. Clean carbon from top ring groove.
5. Place NEW ring in groove (Figure 4) and, using a feeler gauge, measure space between ring and ring land. Compare with reject dimensions listed in Section 12 -

MODEL 200000 HORIZONTAL SERIES

ENGINE SPECIFICATIONS	
Armature Air Gap	.010 - .014 in. (.25 - .36 mm)
Crankshaft End Play	.002 - .028 in. (.05 - .71 mm)
Spark Plug Gap	.030 in. (.76 mm)
Valve Clearance – Intake	.004 - .006 in. (.10 - .15 mm)
Valve Clearance – Exhaust	.004 - .006 in. (.10 - .15 mm)
FASTENER TORQUE SPECIFICATIONS	
	TORQUE
Air Cleaner Base / Backplate	90 lb-in. (10 Nm)
Armature	30 lb-in. (3 Nm)
Blower Housing	90 lb-in. (10 Nm)
Bracket to Carburetor (Snow)	45 lb-in. (5 Nm)
Carburetor Bowl Screw / Solenoid	90 lb-in. (10 Nm)
Carburetor to Cylinder Head	85 lb-in. (10 Nm)
Connecting Rod	100 lb-in. (11 Nm)
Control Bracket	100 lb-in. (11 Nm)
Control Panel Trim	40 lb-in. (5 Nm)
Crankcase Cover	100 lb-in. (11 Nm)
Cylinder Head	220 lb-in. (25 Nm)
Cylinder Shield	30 lb-in. (3 Nm)
Exhaust Manifold / Adapter	180 lb-in. (20 Nm)
Flywheel Nut	120 lb-ft. (160 Nm)
Flywheel Fan	140 lb-in. (16 Nm)
Flywheel Guard	30 lb-in. (3 Nm)
Fuel Tank	90 lb-in. (10 Nm)
Governor Lever Nut	40 lb-in. (5 Nm)
Muffler	180 lb-in. (20 Nm)
Muffler Support Bracket	125 lb-in. (14 Nm)
Oil Drain Cap – Front (Snow)	130 lb-in. (15 Nm)
Oil Drain Plug – Side	100 lb-in. (11 Nm)
Oil Fill Tube	30 lb-in. (3 Nm)
Rewind Starter	30 lb-in. (3 Nm)
Rocker Arm Stud	100 lb-in. (11 Nm)
Rocker Ball Set Screw or Nut	45 lb-in. (5 Nm)
Spark Plug	180 lb-in. (20 Nm)
Starter Cover	20 lb-in. (2 Nm)
Starter Motor	140 lb-in. (16 Nm)
Rocker Cover	75 lb-in. (8 Nm)
Snow Hood	40 lb-in. (5 Nm)
Snow Shield	50 lb-in. (6 Nm)

CLICK HERE TO **DOWNLOAD** THE COMPLETE MANUAL

- Thank you very much for reading the preview of the manual.
- You can download the complete manual from: www.heydownloads.com by clicking the link below



- Please note: If there is no response to CLICKING the link, please download this PDF first and then click on it.

CLICK HERE TO **DOWNLOAD** THE COMPLETE MANUAL