

Parts Book

PMA 540



540

RUBBER TIRED LOADER

SERIAL NUMBERS **540 -5001** and up

 **DRESSER®**

CLICK HERE TO **DOWNLOAD** THE COMPLETE MANUAL

- Thank you very much for reading the preview of the manual.
- You can download the complete manual from: www.heydownloads.com by clicking the link below



- Please note: If there is no response to CLICKING the link, please download this PDF first and then click on it.

CLICK HERE TO **DOWNLOAD** THE COMPLETE MANUAL

**GROUP
14**

SECTION

1

ELECTRICAL SYSTEM

WIRING DIAGRAMS

Brush and Commutator Inspection

- 1 Remove brush cover(s) and remove the brushes from the brush holders. Clean the brushes and holders. Check the brush holders for damage.
- 2 Inspect the condition of the brushes. Remove each brush from the brush holder and inspect the brushes and commutator for worn condition and uneven wear, burning, electrical arcing, etc. The brushes should be worn evenly. Refer to brush inspection chart, page 6.
- 3 Clean the commutator surface. Wipe the commutator with a dry, lint-free cloth. **DO NOT USE LUBRICANT OR SOLVENT ON THE COMMUTATOR.**
- 4 Check appearance of commutator surface where the brushes ride. Inspect the commutator bars for burned, damaged, or raised areas. The best signs of good commutation are a dark brown-colored, highly-polished commutator and uniform glossy brush-wearing surfaces. Refer to the COMMUTATOR CHECK CHART at the end of this section.
- 5 Measure and make a record of brush length at each inspection. The record will verify the amount of brush wear and indicate if there is enough brush length remaining until the next scheduled inspection.
- 6 Brushes must be replaced when worn to approximately half their original length.
BRUSHES MUST BE REPLACED WHEN WORN TO DIMENSION NOTED IN TRUCK SPECIFICATION. REFER TO GROUP 40, SECTION 5.

IMPORTANT

NEW BRUSHES MUST BE THE SAME SIZE AND GRADE (MATERIAL SPECIFICATION) AS THE OLD BRUSHES.

Observe how brushes are assembled in the brush holders, and position of brush lead (brush shunt). New brushes must be installed in same manner.

- 7 Check the tension on the brush springs. Spring pressure (load) on all brushes must be equal. Refer to brush spring tension check below.
- 8 Check brush shunt for good contact with brush holder. Be sure shunt is not damaged or burned, since this may cause brush spring to carry current and lose tension.
- 9 If brushes do not need to be replaced, and commutator is in good condition, install the brushes and brush springs into brush holders. Be sure brush spring is correctly in place on the brush and that brush slides freely in brush box.
- 10 Clean and check brush box and connector screws, as applicable. Tighten if loose. Be sure the brush shunt connection is tight. Install brush cover on motor case.
- 11 Check and tighten all motor bolts. Check the lower nut on each terminal post. It should be installed finger-tight, then tighten another 1/4-turn with a wrench.

Measuring Brush Spring Tension

- 1 Put a piece of paper between the brush and commutator.
- 2 Use a spring scale with its hook or an adapter fitted around the spring between the brush and spring, at the point where the spring presses on the brush.
- 3 Pull the scale to lift the brush spring until the paper under the brush can be moved freely in the direction of rotation of the motor. Measure the tension.
- 4 Replace the spring if the tension is too weak (does not meet the spring tension specification). Refer to GROUP 40, Section 5.

STEER PUMP AND MOTOR REMOVAL FROM TRUCK

NOTICE - Inspection of the steer pump motor requires removal of the sump filter mounting bracket, disconnection of the hydraulic lines from pump, and removal of the motor from its mounting on the front battery plate.

1 Adjust front battery plate for maintenance access. (Refer to GROUP 38, Section 2.)

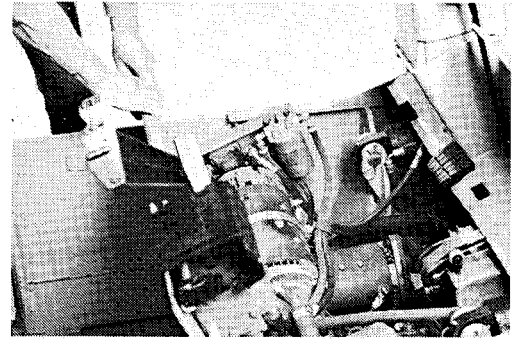

85M861

2 Loosen and remove the nuts from the mounting bolts, then remove hydraulic oil filter mounting bracket from the battery plate.

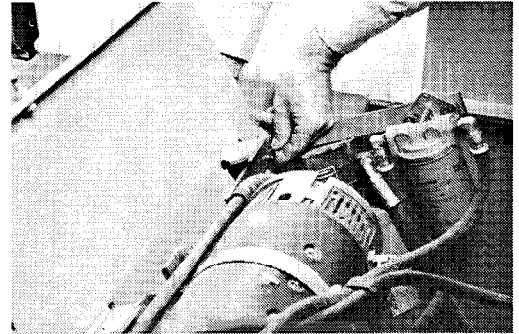

85M707

3 Put the bracket, with hydraulic lines and filter attached, aside out of the way.

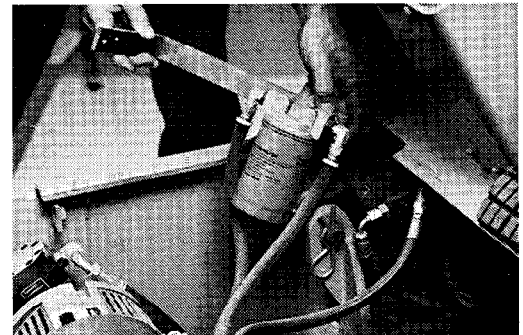

85M682

4 Loosen the clamp and remove intake hose from pump.

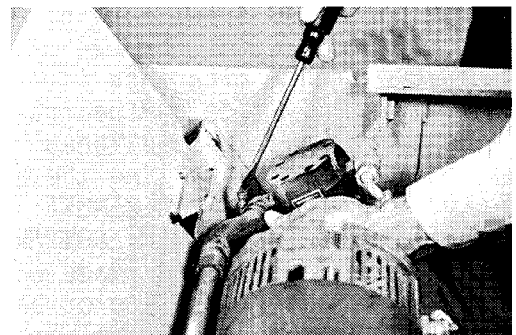

85M695

Steer Axle Trunnion Switch Adjustment

Step 1: Open the battery compartment cover.

NOTICE - Access to the switches will be made much easier when the battery is removed from truck.

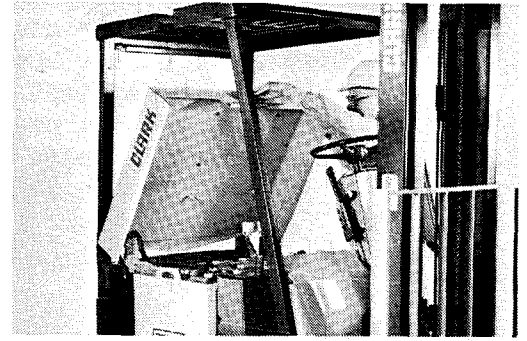

85M616

Step 2: Turn the steer axle wheel to the straight-ahead position.

(Shown in partially-turned position.)

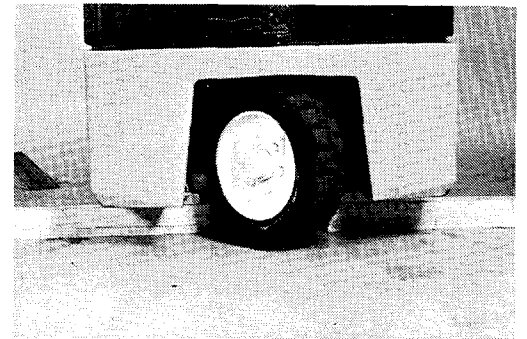

85M774

Refer to illustrations, Pages 2 and 4.

Step 3: For centering of the switches over the cam plate on axle, loosen the mounting screws and 1) adjust the L-shaped bar (13.489) at its attachment to the contactor panel, and/or 2) the switch bracket (65.476) at its attachment to the L-bar. Tighten mounting screws.

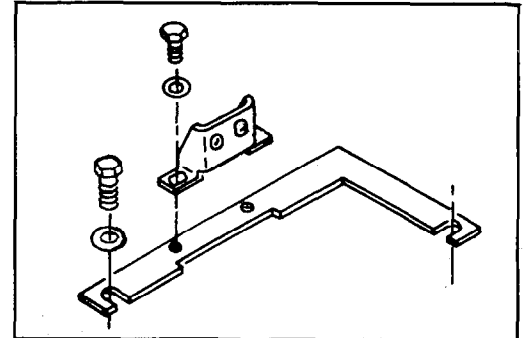

26534

Step 4: For correct height of switch rollers to contact cam plate, loosen mounting screws and adjust the hinged switch bracket assembly (13.684 and 13.192) vertically at its attachment to mounting bracket (65.476) on L-bar.

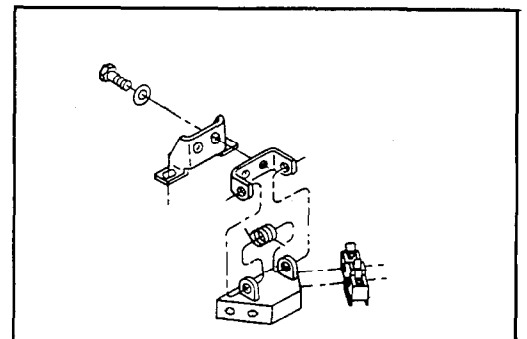

26535

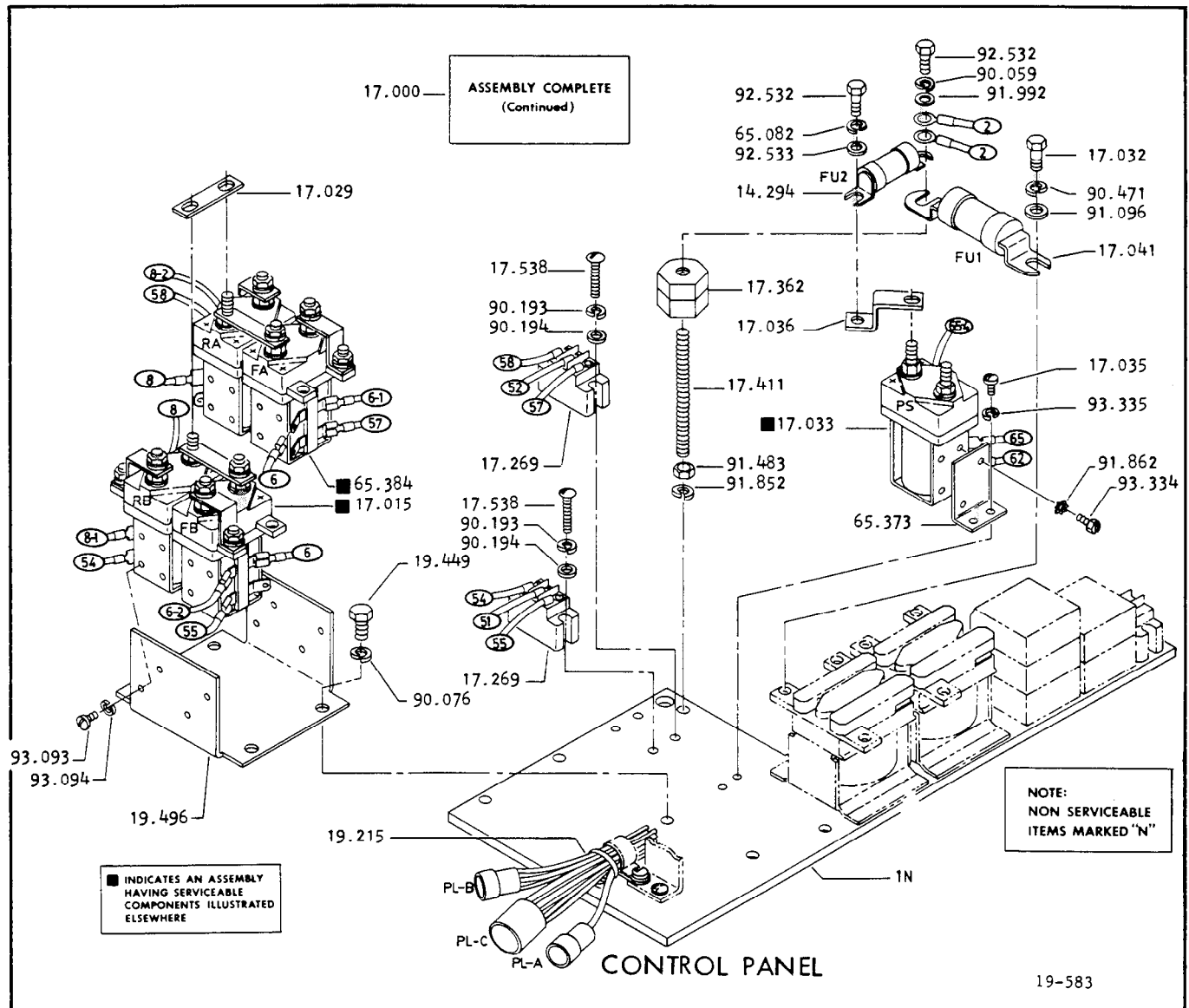

7.000	PANEL ASSEMBLY, ELECTRIC TRUCK CONTROL (CONT'D)	65.384	CONTACTOR ASSEMBLY, FORWARD & REVERSE LH
4.294	FUSE, POWER STEERING CIRCUIT	90.059	LOCKWASHER, POWER FUSE FASTENER
7.015	CONTACTOR ASSEMBLY, FORWARD & REVERSE RH	90.076	LOCKWASHER, FWD & REV CONTACTOR FASTENER
7.029	CONDUCTOR, CONTROL PANEL FWD & REV CONTACTOR	90.193	LOCKWASHER, FWD & REV CONTACTOR DIODE FASTENER
7.032	CAPSCREW, CONTACTOR PANEL POWER FUSE MOUNTING	90.194	WASHER, FWD & REV CONTACTOR DIODE FASTENER
7.033	CONTACTOR ASSEMBLY, POWER STEERING PUMP	90.471	LOCKWASHER, POWER FUSE FASTENER
7.035	FASTENER, CONTACTOR PANEL PWR STRG PUMP CONTACTOR	91.096	WASHER, MAIN FUSE MOUNTING FASTENER
7.036	CONDUCTOR, CONTACTOR PANEL PWR STRG PUMP CONTACTOR	91.483	NUT, CONTACTOR PANEL POWER FUSE MOUNTING FAST
7.041	FUSE, POWER	91.852	LOCKWASHER, CONTACTOR PANEL POWER FUSE MTG BLOCK
7.269	DIODE, FORWARD & REVERSE CONTACTOR	91.862	LOCKWASHER, POWER STRG PUMP CONTACTOR MTG FAST
7.362	BLOCK, MAIN FUSE MOUNTING	91.992	WASHER, CONTACTOR PANEL POWER FUSE MOUNTING FAST
7.411	STUD, CONTACTOR PANEL POWER FUSE MOUNTING BLOCK	92.532	CAPSCREW, CONTACTOR PANEL PWR STRG CIRCUIT FUSE
7.538	FASTENER, FORWARD & REVERSE CONTACTOR DIODE	92.533	WASHER, CONTACTOR PANEL PWR STRG CIRCUIT FUSE FAS
9.215	WIRING HARNESS, CONTACTOR PANEL	93.093	FASTENER, FORWARD & REVERSE CONTACTOR BASE
9.449	CAPSCREW, FORWARD & REVERSE CONTACTOR ASSEMBLY	93.094	LOCKWASHER, FWD & REV CONTACTOR BASE FASTENER
9.496	BASE, FORWARD & REVERSE CONTACTOR	93.334	FASTENER, POWER STEERING CONTACTOR
5.082	LOCKWASHER, PWR STRG CIRCUIT FUSE CONN COND FAST	93.335	LOCKWASHER, POWER STEERING CONTACTOR BRKT FAST
5.373	BRACKET, POWER STEERING CONTACTOR MOUNTING	1N	BASE, CONTACTOR PANEL

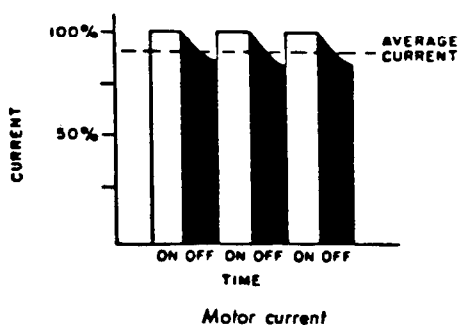

25468

The time for the next ON and OFF cycle to start is determined by the time that the control card takes to oscillate. This frequency of oscillation is controlled by the counter circuit in the accelerator and automatic circuitry in the card. Slow speed is obtained by having maximum volts in the accelerator. As the voltage in the accelerator decreases, the speed of the motor increases. The SCR circuit is capable of delivering approximately 95% speed. For full speed operation, the 1A contactor is closed to apply full battery voltage across the motor.

Control Features

- **Oscillator** - the oscillator section of the card has two adjustable features and one fixed feature. With the accelerator counter circuit at maximum volts, the creep speed can be adjusted by the "creep" trimpot on the card. Top speed is fixed by card design, and is obtained with the accelerator counter circuit at minimum volts. The %ON time has a range of approximately 5 to 95 percent. The center operating condition of the oscillator is at 50 percent ON time with a nominal 1.8 milliseconds ON time and 1.8 milliseconds OFF time. This corresponds to a maximum operating frequency of about 300 hertz. At creep, the ON time will decrease to approximately 0.8 milliseconds while OFF time will become in the order of 20 milliseconds. At full SCR operation, this condition will

be reversed (short OFF time, long ON time). This variation of ON and OFF time of the oscillator produces the optimum frequencies through the SCR range. The frequency curve of the oscillator is shown in Figure 25469.

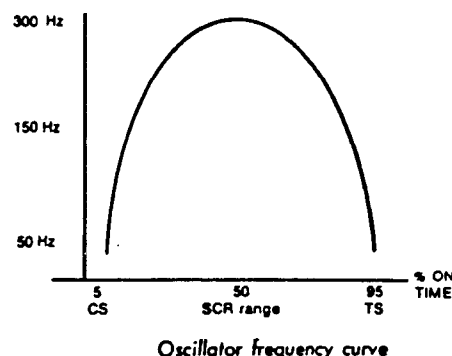

25469

The rate at which the oscillator may increase its % ON time is limited by "Controlled Acceleration". The minimum time required to go from creep speed to 80-85% ON time point may be varied by trimpot (C/A) on the card, adjustable from approximately 0.5 seconds to 3.5-4.5 seconds.

- **Current Limit** - This circuit monitors motor current by utilizing a sensor in series with the armature. The information detected across the sensor is fed back to the card so current may be limited to preset value. If heavy load currents are detected, this circuit overrides oscillator and limits the average current to a value set by the C/L adjustment pot. The C/L setting is based on the maximum thermal rating of 1REC and the peak voltage on the capacitor. Because of the flyback current through 3REC, the motor current usually runs 2 to 3 times battery current. The current limit is set with the "C/L" trimpot on the card.

EV-100 SCR CONTROL
LIFT PUMP AND 1A CONTACTORS

(Refer to GROUP 19, Section 1, for additional information.)

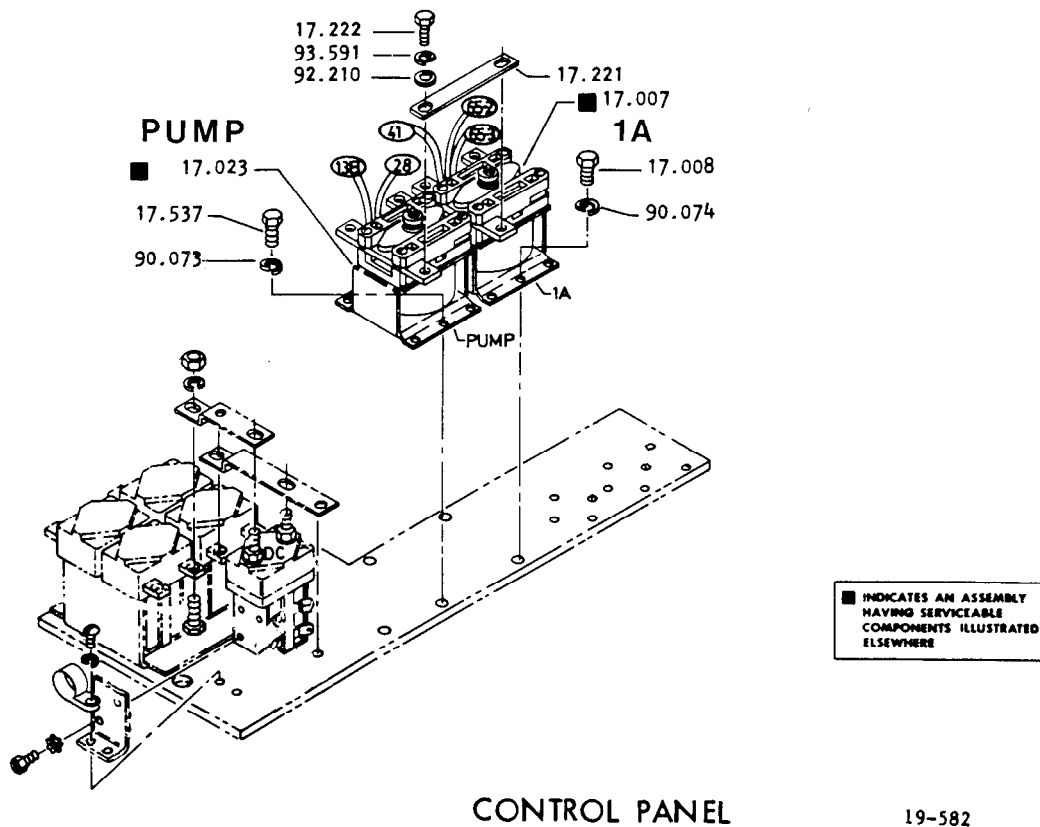

- 17.033 CONTACTOR ASSEMBLY, POWER STEERING
- 17.230 COIL, POWER STEERING CONTACTOR
- 17.240 CONTACT SET, POWER STEERING CONTACTOR
- 17.243 SEAT, POWER STEERING MOVABLE CONTACT SPRING
- 17.244 SPRING, POWER STEERING CONTACTOR MOVABLE CONT
- 19.899 ARMATURE, POWER STEERING CONTACTOR
- 65.052 INSULATOR, P/S CONTACTOR STAT CONTACT SUPPORT
- 90.080 LOCKWASHER, POWER STEERING CONTACTOR FASTENER
- 91.539 LOCKWASHER, PWR STRG CONTACTOR CONDUCTOR FAST
- 91.581 SCREW, POWER STRG STAT CONTACT SUPP INSULATOR
- 93.145 NUT, POWER STEERING CONTACTOR CONDUCTOR
- 93.146 NUT, POWER STEERING PUMP CONTACTOR

POWER STEERING PUMP CONTACTOR

19-168

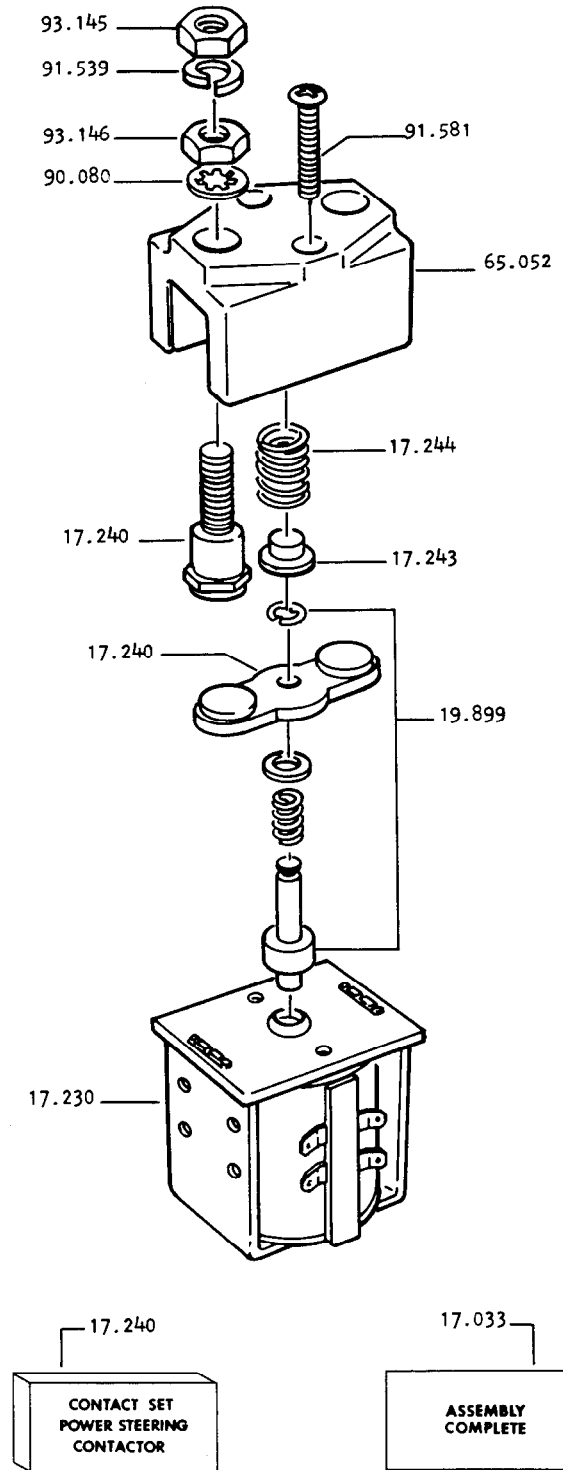

DRIVE AXLE FLUID CHANGE

It is recommended to:

- Drain and replace the drive axle fluid every 1000 operating hours.

To change oil in the drive axle:

- The oil should be drained when it is warmed to operating temperature.
- Put the truck in a level position.
- Apply the parking brake and block the wheels to prevent the truck from moving.
- Turn key switch "OFF" and disconnect battery from truck receptacle.

NOTE - When suitable equipment is available, the truck may be raised or hoisted up and placed in a level position on wheel cradles to allow access under the axle. Otherwise, raise the fork carriage only high enough to provide access clearance to the axle. Please refer to procedure described above in "Access To The Drive Axle", page 2.

NOTICE

Frequent changes of lubricant is an inexpensive way to protect and prolong the safe operating life of an essential and relatively costly major component such as the drive axle.

Extending the recommended intervals at which drive axle fluid is changed should be considered only after careful evaluation of your operating conditions and/or analysis of the condition of the oil.

Refer to
GROUP 38, Section 3,
Machine Jacking and
Blocking.

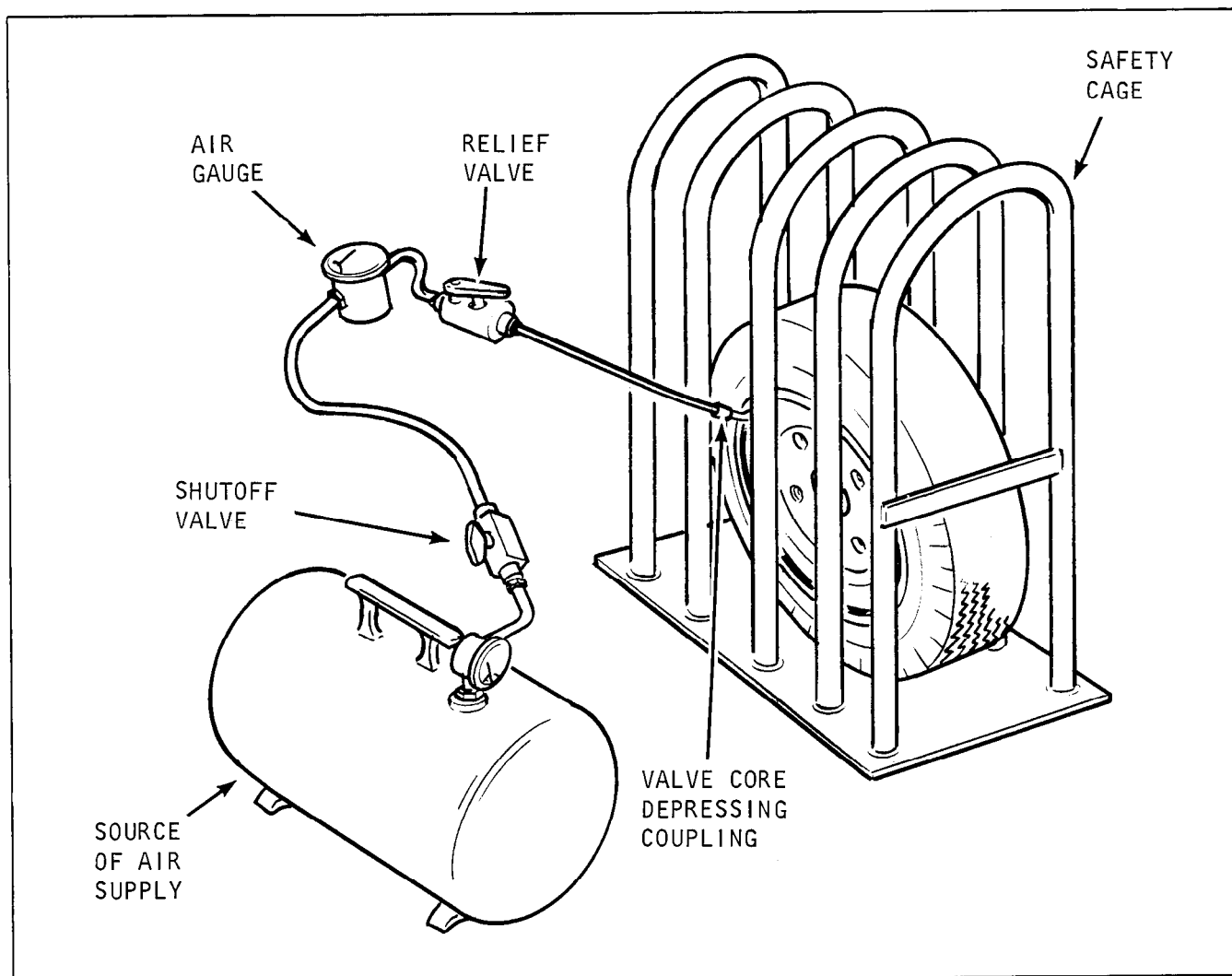

Fig. 9702 Typical Tire Filling Procedure

Filling Tires With Air

All wheel and tire assemblies must be filled in a safety cage. The air hose and components should be arranged as shown in Fig. 9702. The hose must have an adapter that can be connected to the valve stem.

1. Attach an air hose to valve stem.
2. Open the control valve which will let compressed air into the tire.

3. At intervals, close the control valve and check the pressure in the tire by reading the gauge. Do not put too much pressure into the tire.
4. Continue to fill the tire to the correct capacity.

I M P O R T A N T

PUT EQUAL AIR PRESSURE IN BOTH TIRES OF A DUAL ASSEMBLY. DO NOT PUT AIR INTO A TIRE THAT IS FLAT WITHOUT FIRST INSPECTING IT AND THE WHEEL FOR DAMAGE.

BRAKE BLEEDING PROCEDURE

NOTICE - The service brake system on this truck model uses conventional SAE/DOT 3 heavy duty automotive hydraulic brake fluid only.

Normally a minimum of brake bleeding will be required. The brake system is designed to place the master cylinder reservoir at the highest point in the circuit. This ensures that the major part of any air that has entered the system will flow upwards and vent into the reservoir. The recommended brake bleeding procedure outlined below is intended to dislodge and remove any entrapped air from the circuit.

IMPORTANT - Service brake pedal free play must be correctly adjusted before bleeding brakes.

Check frequently and keep master cylinder reservoir filled during bleeding.

Refer to Page 7 for illustration of brake lines installation.

1 Remove floorboard.

NOTICE - More space will be available if brake bleeding is performed when battery is removed and front battery plate is adjusted for service access.

Refer to GROUP 38, Section 2, Front Battery Plate Adjustment.



85M506

2 Remove access cover from pylon.

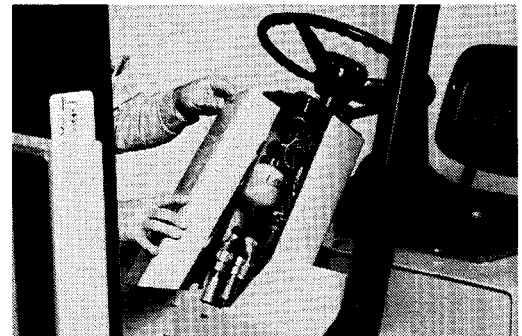

85M510

CLICK HERE TO **DOWNLOAD** THE COMPLETE MANUAL

- Thank you very much for reading the preview of the manual.
- You can download the complete manual from: www.heydownloads.com by clicking the link below



- Please note: If there is no response to CLICKING the link, please download this PDF first and then click on it.

CLICK HERE TO **DOWNLOAD** THE COMPLETE MANUAL

GROUP 26

SECTION 1

STEER AXLE TRUNNION BEARINGS CHECK AND ADJUSTMENT

⚠ CAUTION

To perform this service procedure, it is recommended that you first:

- Park the truck on a level surface and fully lower the upright.
- Return all controls to neutral, and turn key switch to the "OFF" position.
- Apply the parking brake.
- Lift and block the truck up to raise the steer axle wheel off the floor.

Refer to GROUP 38, Section 3, Machine Jacking and Blocking.

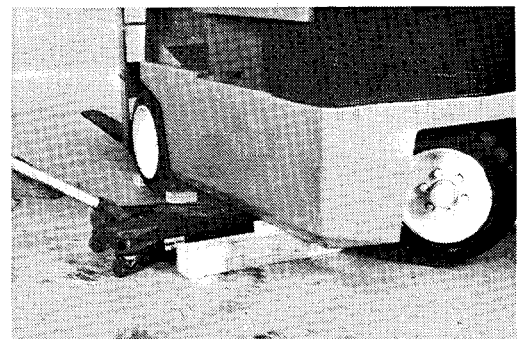

85M775

STEER WHEEL BEARING MAINTENANCE

- 1 Be sure that truck is parked and blocked up correctly to raise the steer wheel off the floor. NOTE - It is optional to raise and block up entire truck.

See **CAUTION**, Page 1.

Refer to PM section, Page 6.9, for additional steer axle inspection notes.

- 2 To check the steer wheel bearings for excessive free play or looseness, hold the wheel with both hands and try to move it by a rocking motion from side to side. Also, try to pull it in and out along the wheel spindle. There should be a small amount of free movement. The maximum allowable end play is [0,08 mm] .003 inch. If the wheel has excessive end play, the bearings require additional service and/or adjustment.

Steer Wheel Bearing Adjustment

The steer wheel bearings are retained and adjusted by a self-locking bearing nut.

Step 1: Remove hubcap by tapping lightly on the outer edge of hubcap. (Reference Figure 85M883, shown here with wheel removed).

Step 2: Loosen spindle (bearing adjusting) nut.

NOTICE - After spindle nut is loosened, hit the top of wheel (tire) to loosen (unseat) the bearings. This moves the bearings free of their seated, running position.

IMPORTANT - Spindle nut should be replaced with a new one each time it is removed because holding torque capability is partially destroyed with each removal.

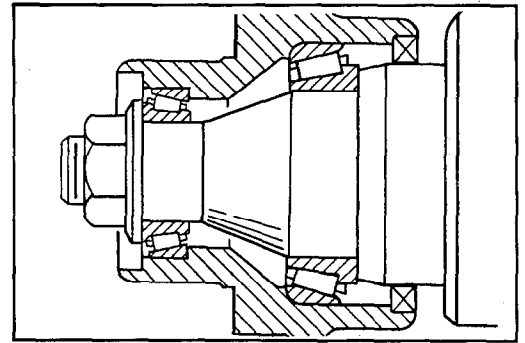

26520

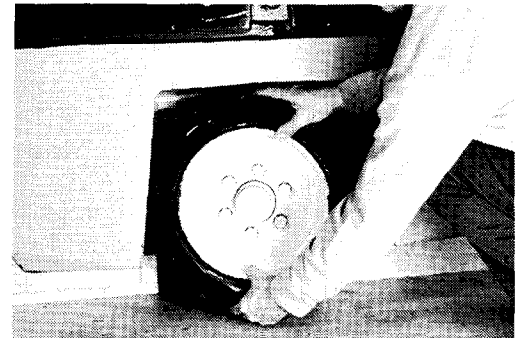

85M747

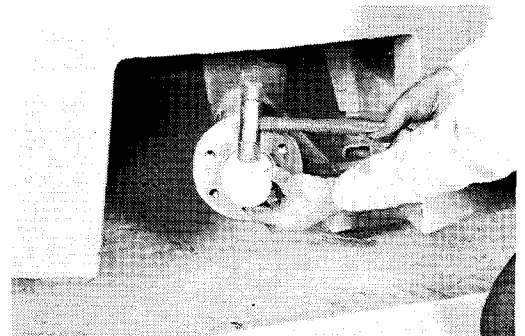

85M883

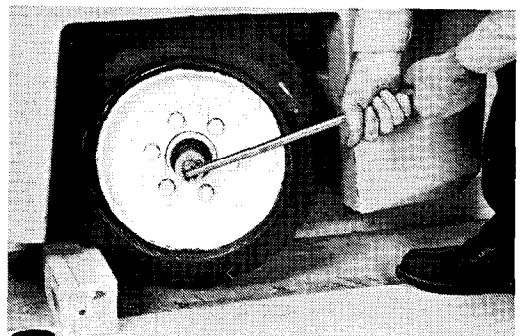

85M892

- 13 When the relief pressure reading has been obtained:
- 14 Turn key switch "OFF".
- 15 Move direction control lever to neutral.
- 16 Apply parking brake.
- 17 Disconnect pressure gauge, remove the temporary Tee fitting, and install elbow and steer line as initially installed. Be sure to correctly tighten all fittings.
- 18 Install access cover on pylon.

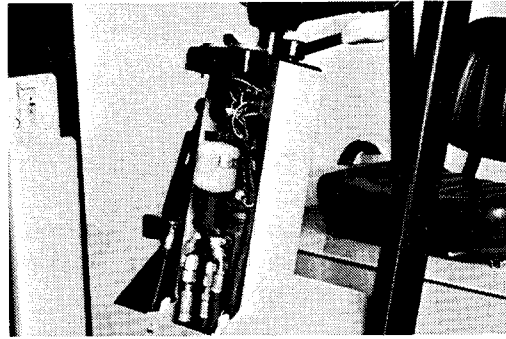

85M635

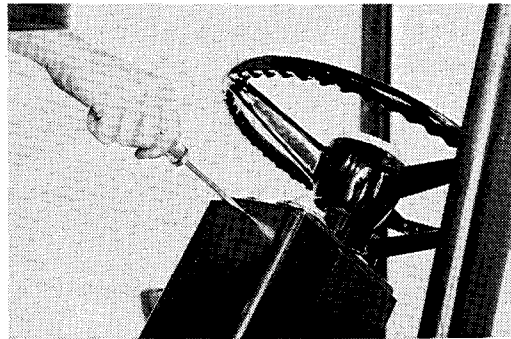

20283

- 19 Remove blocking from under the upright.

NOTICE - If steering system relief pressure setting is not correct, refer to Overhaul Manual OH-540, for correct maintenance procedures.

- 3 Remove the snap-on cap and connect a suitable drain hose line to the diagnostic check port fitting located on side of main hydraulic valve. NOTE - Use quick-disconnect adapter fitting, Clark Part No. 3797029.

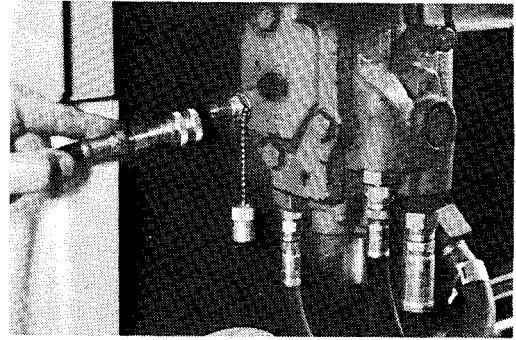

85M552

- 4 You will need a drain pan of [9.8-17 L] 2.6-4.5 gal minimum capacity, or other method of disposal, for collecting the used oil. Be sure the outlet end of the drain line is directed into the drain pan and held from moving when pressurized.

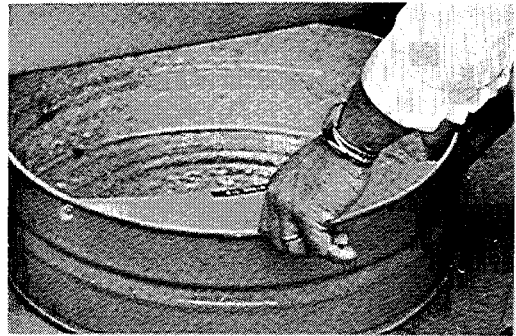

12171

NOTICE - If battery is removed, use an adapter cable connected between battery and truck receptacle to power hydraulic system.

- 5 Turn key switch to "ON" position.
- 6 Move tilt control lever to the back tilt position to start the lift pump. Hold tilt lever in this position until sump tank is emptied. See below.

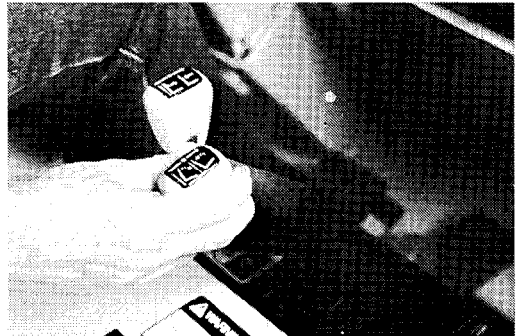

85M489

A steady stream of used hydraulic oil should flow from the drain line.

- 7 Continue operation until the sump tank is emptied. This point will be reached when the pump starts to cavitate. When cavitation occurs the pump speed will increase. A change in pump speed pitch will be heard. Also, watch the drain line. The oil flow will become erratic or will stop when the pump can no longer pick up oil from the sump tank.
- 8 Release the tilt lever immediately when pump cavitation occurs.

IMPORTANT

BE CAREFUL WHEN SUMP IS NEARLY EMPTIED. WATCH FOR SIGNS OF PUMP CAVITATION. DO NOT OPERATE PUMP AFTER CAVITATION OCCURS.

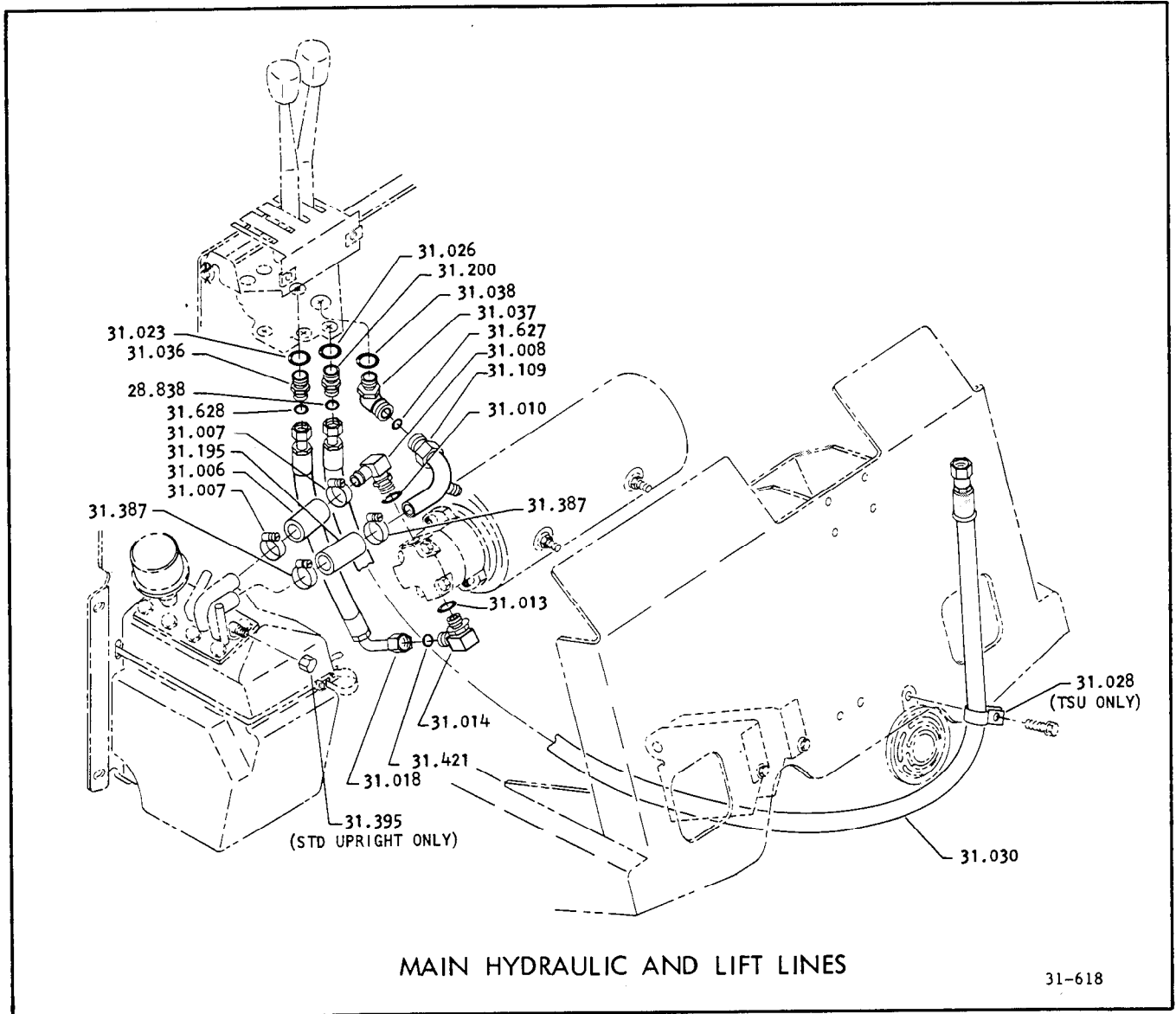

28.838	SEAL, HYDRAULIC VALVE LIFT PORT FITTING	31.036	FITTING, HYDRAULIC VALVE INLET PORT
31.006	LINE, HYDRAULIC PUMP INLET	31.037	FITTING, HYDRAULIC VALVE DISCHARGE PORT
31.007	LINE, PUMP INLET	31.038	SEAL, HYDRAULIC VALVE DISCHARGE PORT
31.008	FITTING, HYDRAULIC PUMP INLET PORT	31.109	LINE, HYDRAULIC VALVE DISCHARGE
31.010	SEAL, HYDRAULIC PUMP INLET PORT	31.195	LINE, VALVE TO SUMP RETURN
31.013	SEAL, HYDRAULIC PUMP OUTLET PORT	31.200	FITTING, HYDRAULIC VALVE LIFT PORT
31.014	FITTING, HYDRAULIC PUMP OUTLET PORT	31.387	CLAMP, VALVE TO SUMP RETURN LINE
31.018	LINE, HYDRAULIC PUMP OUTLET	31.395	CAP, LIFT CYLINDER VENT SUMP INLET
31.023	SEAL, HYDRAULIC VALVE INLET PORT	31.421	SEAL, PUMP OUTLET PORT FITTING
31.026	SEAL, HYDRAULIC VALVE LIFT PORT	31.627	SEAL, LIFT VALVE RETURN PORT
31.028	CLIP, VALVE OUTLET LINE SUPPORT	31.628	SEAL, LIFT VALVE INLET PORT
31.030	LINE, HYDRAULIC VALVE LIFT		

GROUP 34

SECTION

4

FORK MAINTENANCE

⚠ WARNING

FORKS ARE AN IMPORTANT SAFETY ELEMENT OF THE LIFT TRUCK. THEY MUST BE CAREFULLY INSPECTED AT EACH PM INTERVAL AND ALWAYS MAINTAINED IN A SAFE CONDITION.

FORKS THAT ARE BENT OR TWISTED WILL CAUSE THE LOAD TO SHIFT OR SLIDE OFF AND BE DROPPED. FORKS THAT ARE CRACKED OR WORN EXCESSIVELY CAN BREAK SUDDENLY AND CAUSE SEVERE INJURY OR DEATH.

III. LIFT CHAIN REPLACEMENT:

Find the manufacturer's stamped number on the links of the chain. Your Clark Dealer will need this number to make sure you are getting the correct chain for your truck. Leaf chain is available in lengths up to [7,62 m] 25 ft. Short sections of leaf chain must never be joined together to form a longer length. Roller and rollerless chain is available in [3,05 mm] 10 ft. sections. Never join new chain sections to old chain sections.

Lift chains must always be replaced as pairs. It is impossible to keep a balanced load between chains if a new chain is put into service opposite an old chain. The joints in the old chain may have worn through the hardest layer of the case-hardened pins, and the old chain will wear much faster than the new chain, causing problems keeping chain tension equal. Also, the new chain will wear more slowly, causing it to hold most of the load, resulting in early wear and failure.

Do not remove the lubricant from new chains. The manufacturer's lubricant helps prevent wear and corrosion. If the original factory lubrication has dried or been removed, apply Clark Chain and Cable Lube #886399.

After the old chains have been removed from the upright, very carefully inspect the chain anchors and sheaves. Broken, cracked, or worn anchors must be replaced. Replace worn sheaves, and check the sheave bearings for wear.

Do not paint new chain before or after installation. Paint will help prevent corrosion, but will also prevent lubricant from reaching the pin surface for good joint lubrication.

Use new anchor pins when installing new chains. Old pins may contain fatigue cracks that could cause failure. After the chains have been connected to the anchors, adjust the chain tension.

Correct chain installation and upright adjustment will increase chain service life.

CHECK LIST
LIFT CHAIN MAINTENANCE

- A. LIFT CHAIN INSPECTION:
Every truck PM (50-250 hours) check for:
1. Cracked Plates
 2. Rust and Corrosion
 3. Turned Pins
 4. Tight Joints
 5. Wear - measure portion of chain that flexes over sheaves using a steel tape.
- B. LIFT CHAIN LUBRICATION:
Every truck PM (50-250 hours) 50 hrs. in corrosive environment
1. Apply Clark Chain and Cable Lube #886399
 2. Lubricate full length of all strands.
- C. LIFT CHAIN REPLACEMENT:
1. All chains must be replaced if any strand has wear of 3% or more or if any of the conditions listed in Section I are found during inspection.
 2. Order replacement chains from your Clark Dealer.
 3. Replace all chains as a set.
 4. Do not remove lubricant or paint new chains.
 5. Replace anchor pins and worn or broken anchors when installing new chains.
 6. Adjust tension on new chains.

- 8 Move counterweight for storage. It is recommended to use a load platform (pallet, or equivalent) of adequate (correct) construction and capacity for temporary or permanent storage, and for movement (transport) of the counterweight.

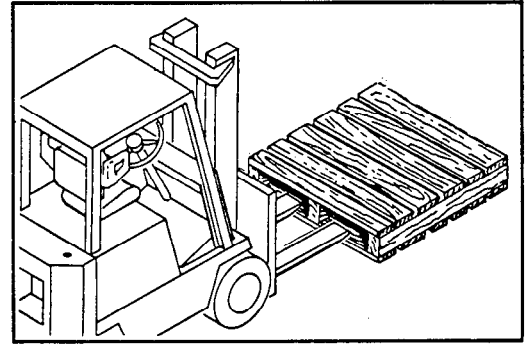

25436

- 9 Carefully lower the counterweight onto the load platform or floor. When storing on a platform or the floor, always put the counterweight in a stable condition with the broad, flat side down.

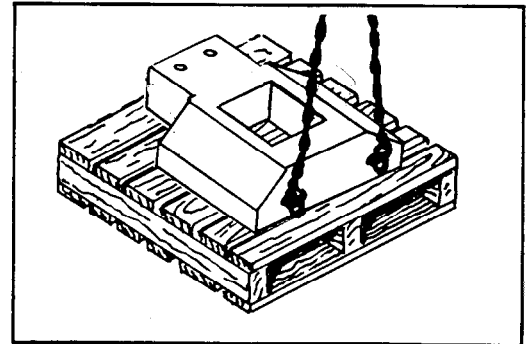

25437

- 10 Remove the lifting chains or sling. Remove the eye bolts if counterweight is to be stored permanently (not immediately used).

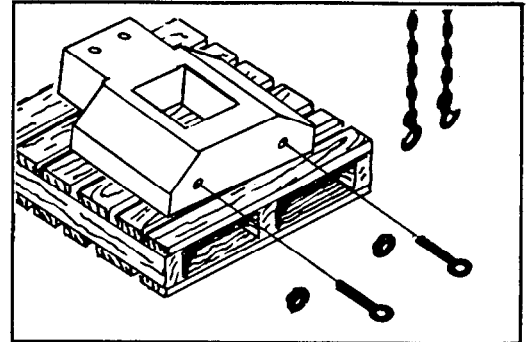

25438

- 11 If counterweight must be stored on its curved side for inspection or servicing, be sure to put adequate blocking at each side to prevent rolling or shifting.

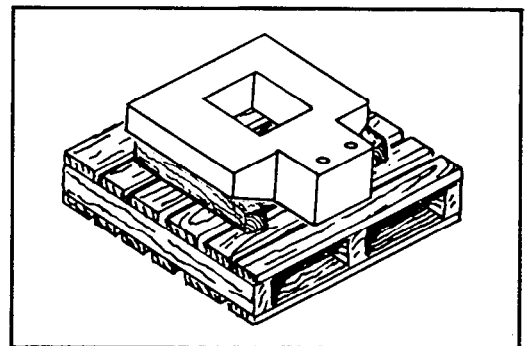

25439

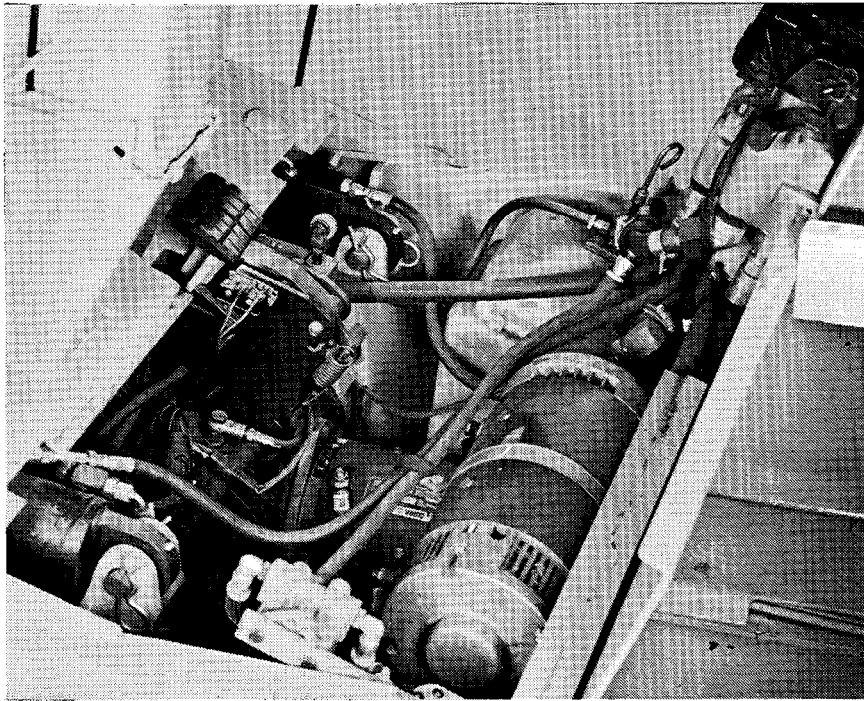

85M762

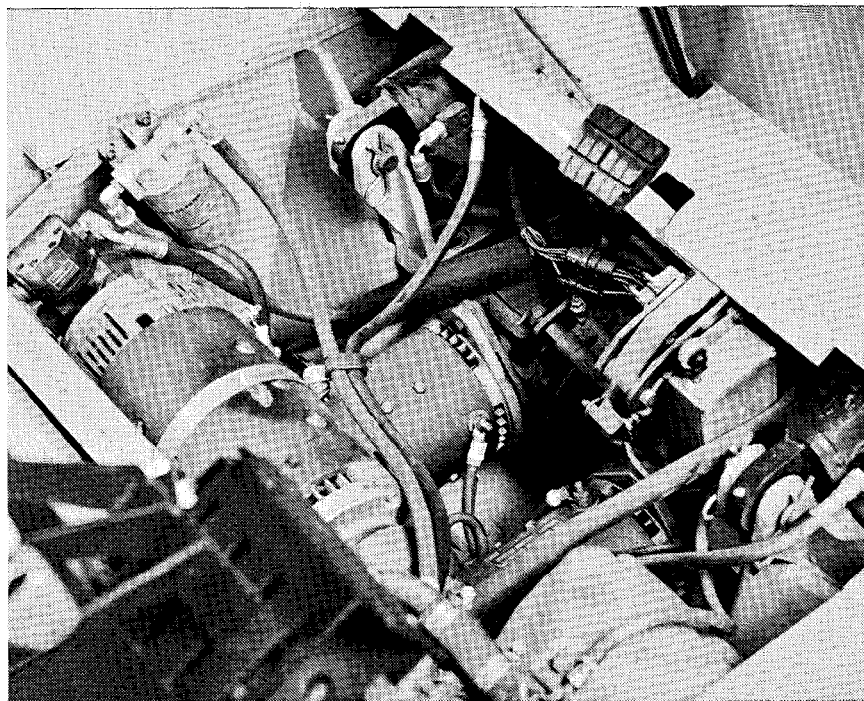

85M862

- 6 Lower the truck onto the blocks and move the jack to the opposite side. Repeat the lifting procedure.
- 7 Put the same size blocks under each side of the truck so it will be level.

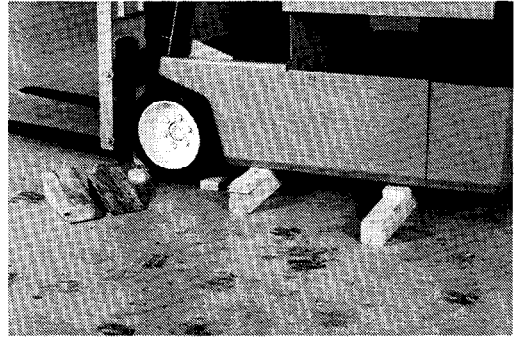

85M778

CAUTION - Before performing any maintenance work, check the truck for stable condition on the blocking.

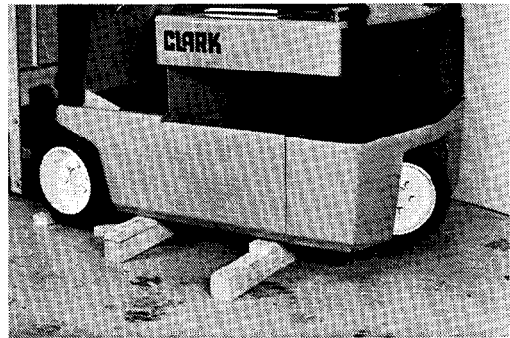

85M776

- 8 When maintenance work is completed, lower the entire truck to the floor by reversing the lifting procedure.

Lower the truck one side at a time, while carefully removing the blocks. Check to be sure that no tools or equipment are under the truck or wheels.

NOTE - Depending on jack height, shims under the tires may be needed for clearance to allow removal of jack.

8 The hood may now be removed from truck.

Note - Hinge bracket and tapping block may be temporarily reinstalled on hood for safe storage.

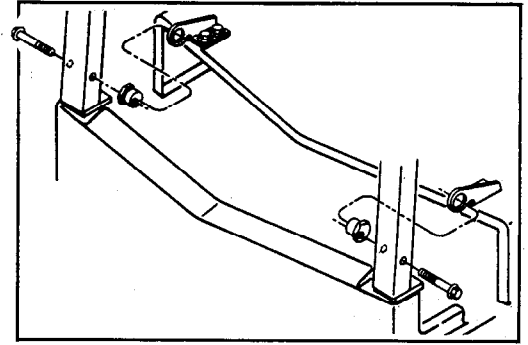

25471

9 If required, remove the hood pivot pins from the OHG legs. Loosen and remove the mounting bolt from each pivot pin. Put a match-mark on each pivot pin and OHG leg for adjustment of hood when installed.

Bolt Torque: [40-45 N.m] 30-35 lbf.ft.

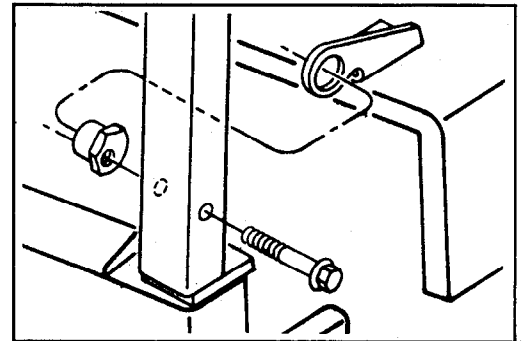

25472

Hood Installation

Reverse the above procedures for hood installation.

1 Lift hood assembly and set it temporarily into place on truck, in the lowered position. Engage hood hinge bracket (attached to hood) to hinge pin on OHG leg.

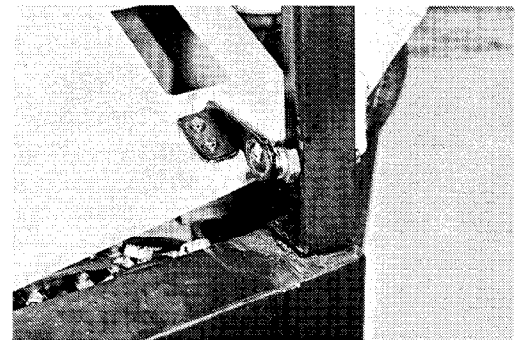

85M786

2 Carefully rest hood in lowered position without latching. Slide the other hinge bracket onto hinge pin on OHG leg (Figure 85M784), install and tighten the two hinge bracket mounting bolts with tapping block (underside of hood).

Bolt torque: [20-25 N.m] 117-221 lbf.in.

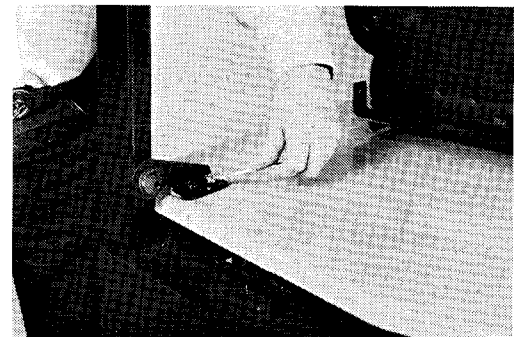

85M797

**GROUP
40**

**SECTION
3**

FIRE EXTINGUISHER RECOMMENDATIONS

11. SPLINE GREASE

FOR ... MOTOR TO PUMP DRIVE TANG CLARK PART NUMBER 1800531
 HYDRAULIC PUMP & MOTOR
 SHAFT SPLINES

MOLY GREASE

SPECIFICATIONS A lithium base or equal multi-purpose grease blended with selected additives to provide high load-carrying capacity with superior protection against corrosion and high-temperature oxidation and containing 3 (to) 5% moly (molybdenum disulfide). NLGI #2.

NOTE: Grease products under this specification are suitable for use on ball and roller bearings operating under extreme loads or in severe environments, and for extended lubrication intervals including chassis, sleeve bearings, cams and sliding mechanisms, etc., under heavy loads, shock and vibration.

12. SPECIAL LUBRICANT
HAND APPLIED

For ... SLIP TUBES, SLEEVES, CLARK PART NUMBER 617410
 SPRING APPLIED SLEEVES,
 LINKAGE BALL JOINTS, ETC.

SPECIFICATIONS A soft density, smooth lithium base or equivalent grease with extreme pressure properties for use in adverse operating conditions from 0° F. to 250° F. NLGI #1.

13. PROTECTIVE SPRAY COATING
- ELECTRIC TRUCKS IN COLD STORAGE
& OTHER APPLICATIONS

FOR ... ELECTRICAL SWITCHES, CLARK PART NUMBER 886784
 WIRING & TERMINALS,
 AFTER ASSEMBLY.

SPECIFICATIONS A clear acrylic plastic protective coating which acts as an insulator and corrosion preventative.

Truck Specifications

20 DRIVE UNITS (TWO)

Recommended Oil Specification: DEXRON II ATF Automatic Trans Fluid
Drive Unit Oil Capacity, Each: [3.81 L] 8 pints
Overall Ratio: 23.386:1 Reduction

23 WHEELS & TIRES: (Tire sizes are common to all models, except as noted)

Drive Tire Size - Cushion 18x7x12.12 (TM15) 18x8x12.12 (TM17,20)
- Pneumatic 18x7 - 8 16-ply
Tire Pressure - [970 kPa] 140 psi

Steer Tire Size - Cushion 18x7x12.12
- Pneumatic 18x7 - 8 16-ply
Tire Pressure - [970 kPa] 140 psi

23 BRAKES

Recommended Brake Fluid: Heavy-duty hydraulic brake fluid,
SAE J1703b specification, or
Type DOT, Grade DOT 3.
Master Cylinder: 0.75 in Dia. x 0.787 in Stroke

26 STEERING SYSTEM:

Recommended Power Steering Fluid: Uses main hydraulic sump oil supply.

Power Steering System Relief Pressure Setting: [8620 kPa] 1250 psi

Steer Cylinder Diameter: 2.00 inch

Steer Handwheel Turns, Lock-to-Lock: 5 (Cyl extending), 4 (Cyl retract'g)

29/30 HYDRAULIC SYSTEM:

Recommended Hydraulic Fluid: Clark Specification MS-68 Hydraulic Oil
w/anti-wear additives

Sump Tank Capacity, Usable Volume: [9.84 L] 2.6 gal
Total Volume: [13.6 L] 3.6 gal

Main Hydraulic Valve (Lift & Tilt)

Relief Pressure Setting: TM 15: [16890-17580 kPa] 2450-2550 psi
TM 17: [18620-19306 kPa] 2700-2800 psi
TM 20: [20340-21030 kPa] 2950-3050 psi

Aux Valve Relief Pressure Setting: Adjustable - Refer to
attachment specifications.

CLICK HERE TO **DOWNLOAD** THE COMPLETE MANUAL

- Thank you very much for reading the preview of the manual.
- You can download the complete manual from: www.heydownloads.com by clicking the link below



- Please note: If there is no response to CLICKING the link, please download this PDF first and then click on it.

CLICK HERE TO **DOWNLOAD** THE COMPLETE MANUAL