

# P R E F A C E

1. This Parts Catalog carries Yanmar crawler back-hoe Vio27-2(for Japan)

2. Parts catalog history

|             | Parts catalog NO. | Published   | Remarks            |
|-------------|-------------------|-------------|--------------------|
| 1st edition | 000Y00K3680       | Sep. , 2000 | Disuse old edition |
| 1st revised | 000Y00K3681       | Nov. , 2001 | Disuse old edition |
| 2nd revised | 000Y00K3682       | Nov. , 2003 |                    |

3. Model name

| SECTION     | Column | Model name    | M/#    | Manufactured |
|-------------|--------|---------------|--------|--------------|
| I (Vehicle) | (A)    | Vio27-2 C(JP) | 20501~ | 2000/6~      |
|             | (B)    | Vio27-2 P(JP) |        |              |
|             | (C)    | Vio27-2 P(EX) | 21093~ | 2002/5~      |
| II (Engine) | (A)    | 3TNE78A-EBV   | 43271~ | 2000/5~      |

(Note) C:Cabin spec. P:Canopy spec.

4. Your understanding is asking that this parts catalog is not a technical data manual setting forth as servicing procedures, This parts catalog is using simplified illustration. Be sure to use Yanmar Genuine Parts in your maintenance servicing of Yanmar products. Be careful not to use the simple parts available in the market, otherwise their use in repairing causes such as an early breakage, for instance.

CLICK HERE TO **DOWNLOAD** THE COMPLETE MANUAL

- Thank you very much for reading the preview of the manual.
- You can download the complete manual from: [www.heydownloads.com](http://www.heydownloads.com) by clicking the link below



- Please note: If there is no response to CLICKING the link, please download this PDF first and then click on it.

CLICK HERE TO **DOWNLOAD** THE COMPLETE MANUAL

絵目次 (3) . . . . . 項目別  
PICTURESQUE INDEX (3) . . . FIGURE

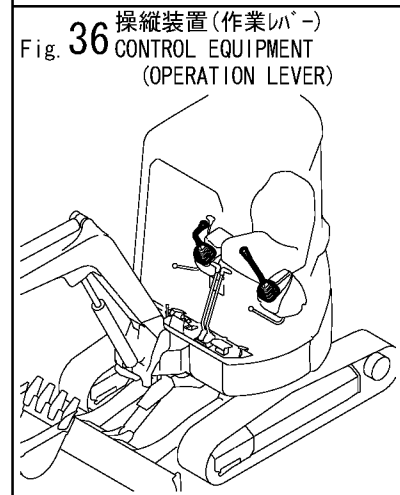
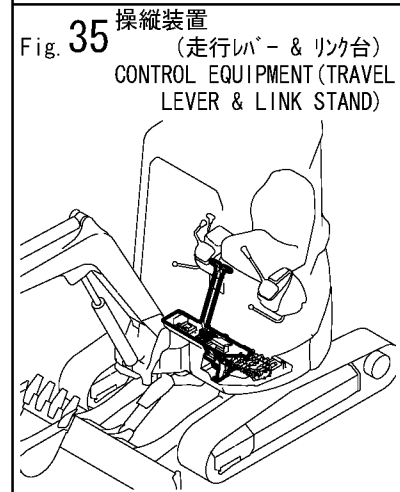
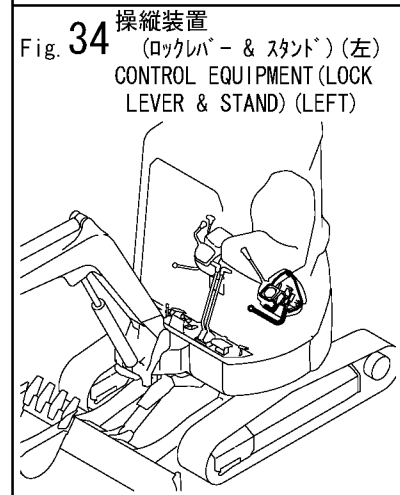
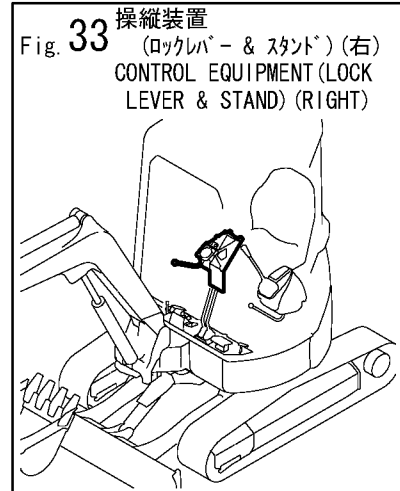
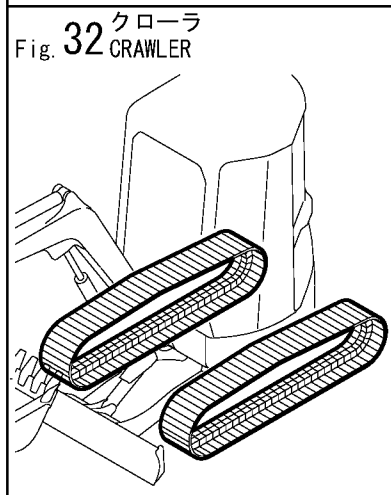
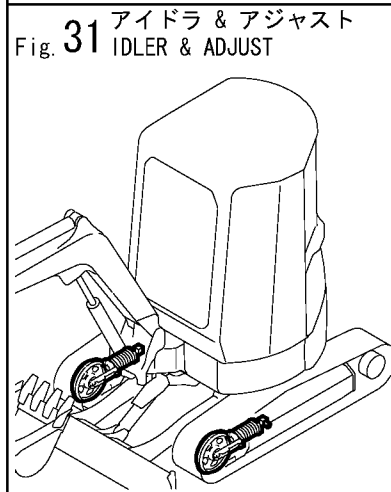
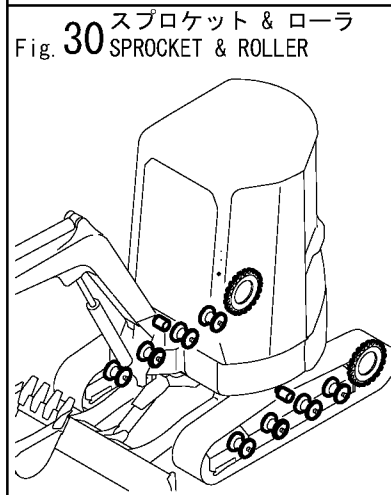
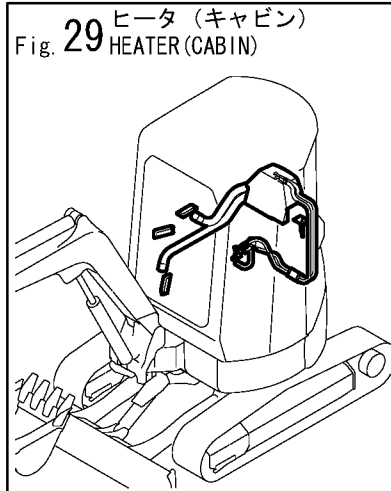
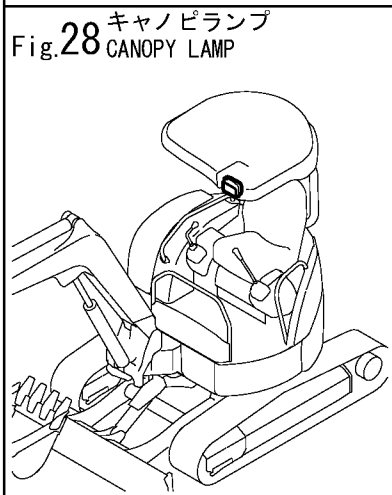
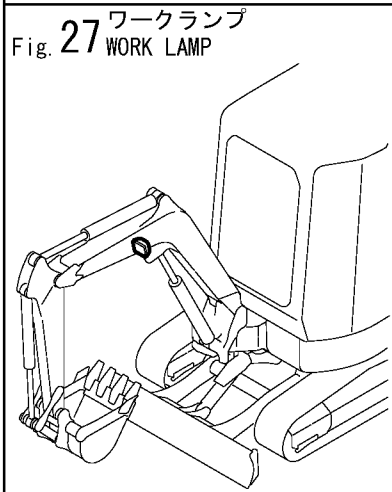
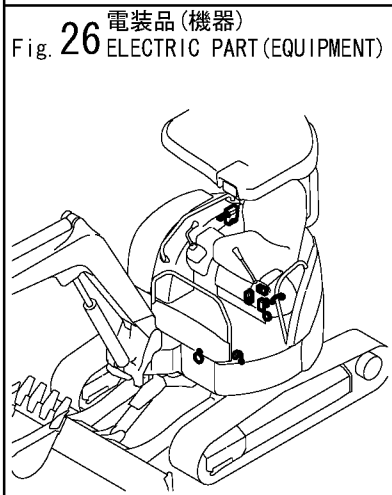
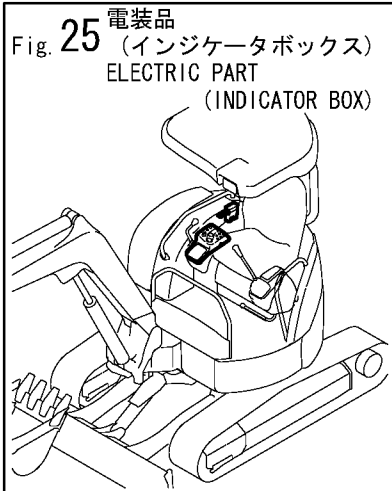

見出しNo. 1は  
見出しNo. 2から54を含みます。  
1 INC. 2~54.

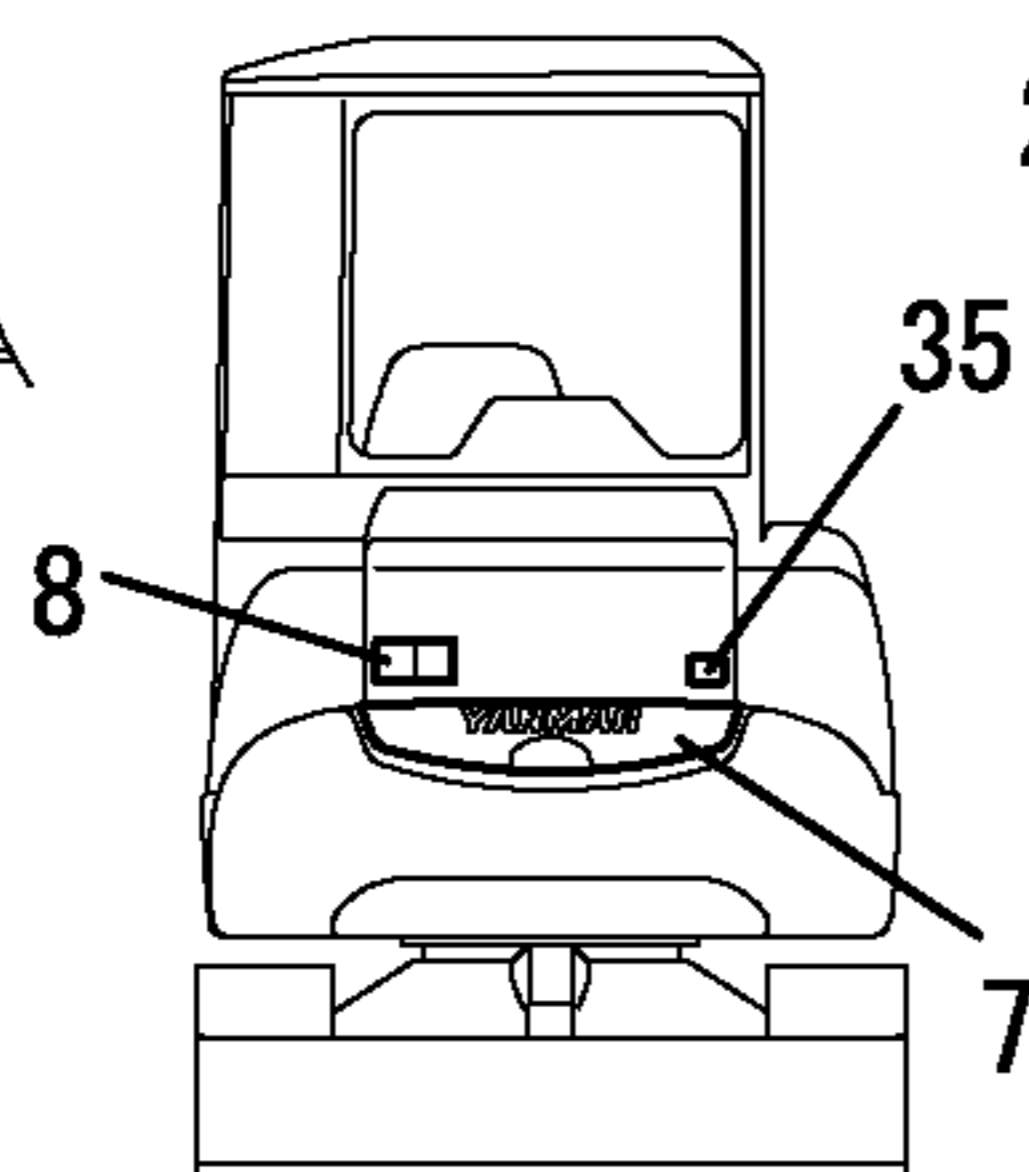
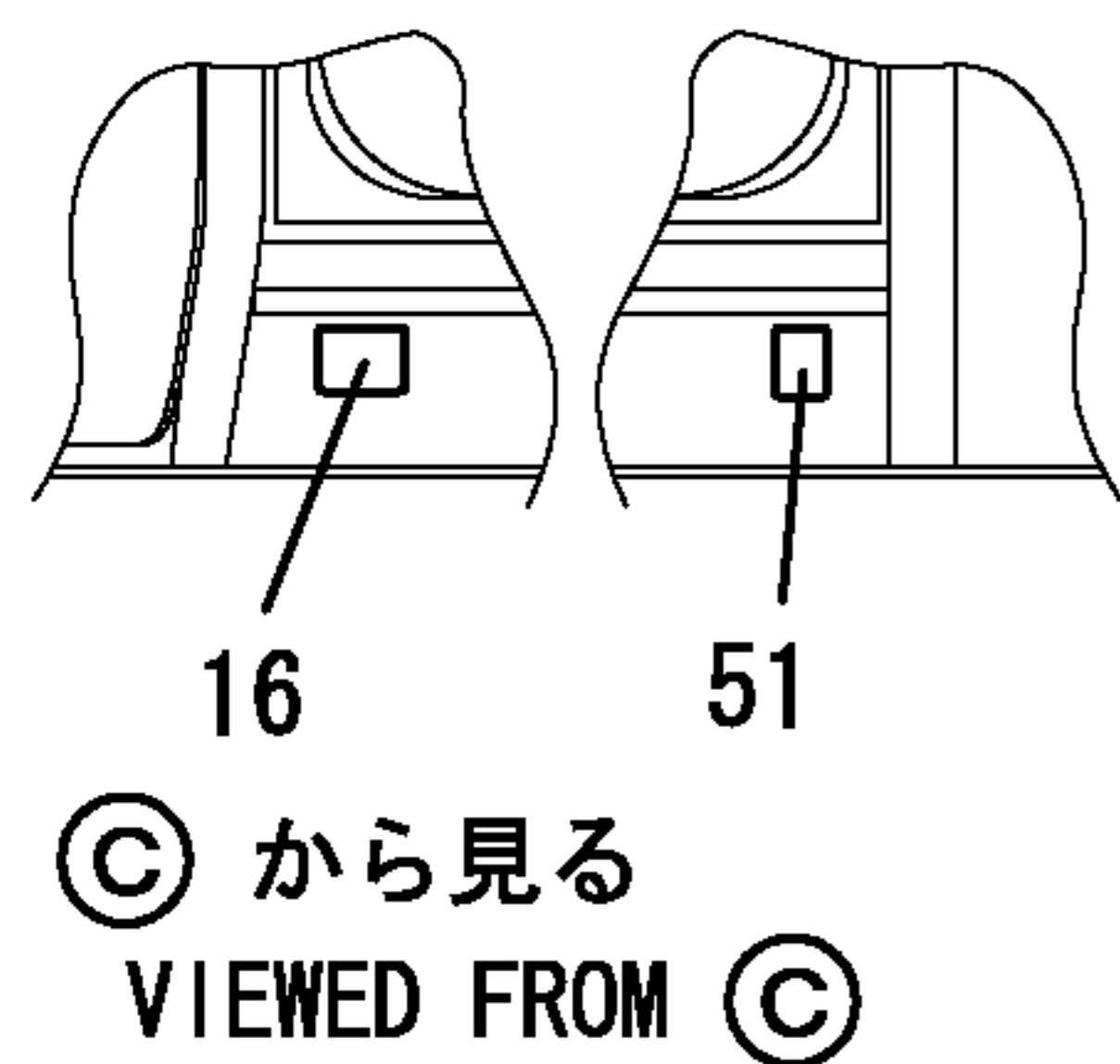
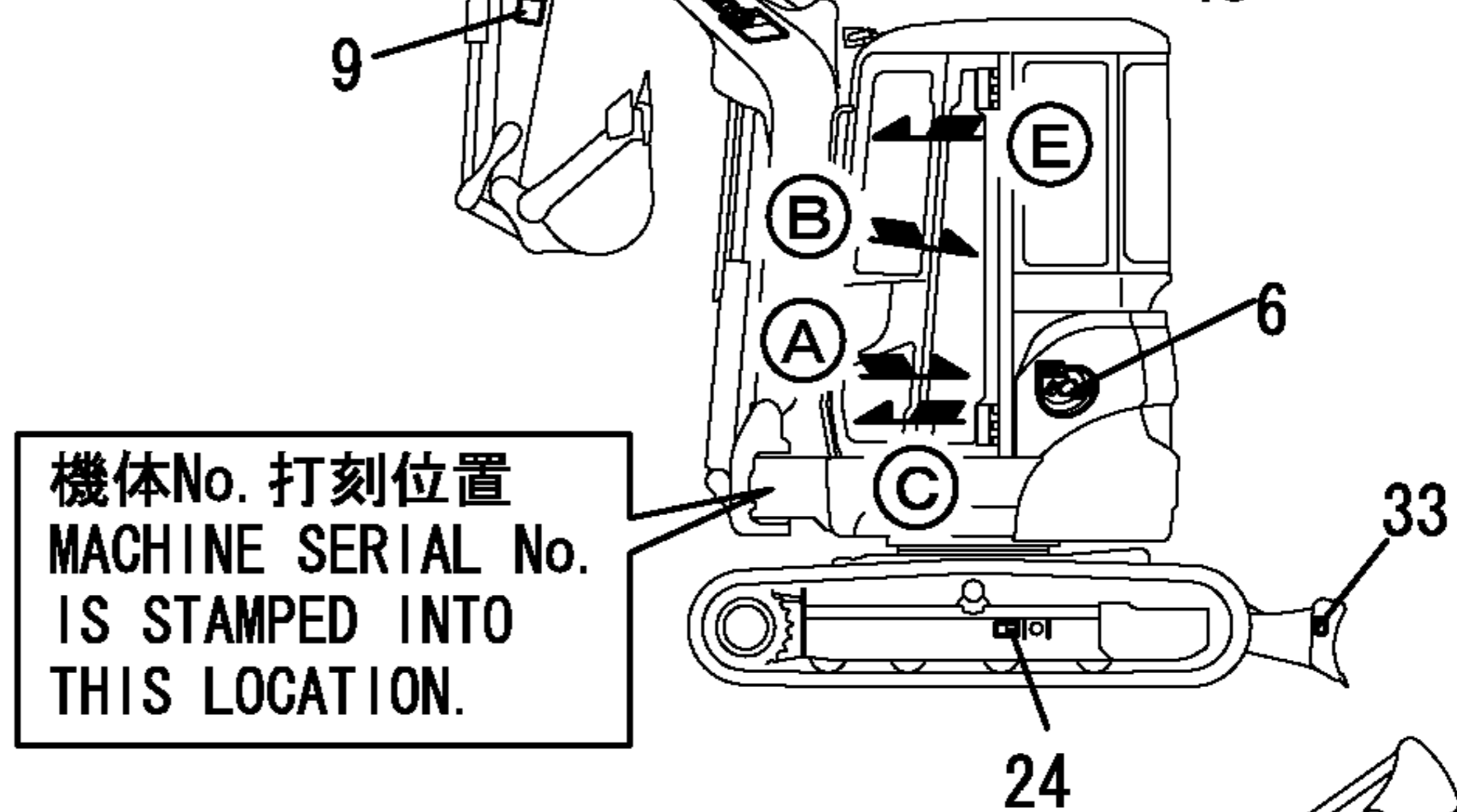
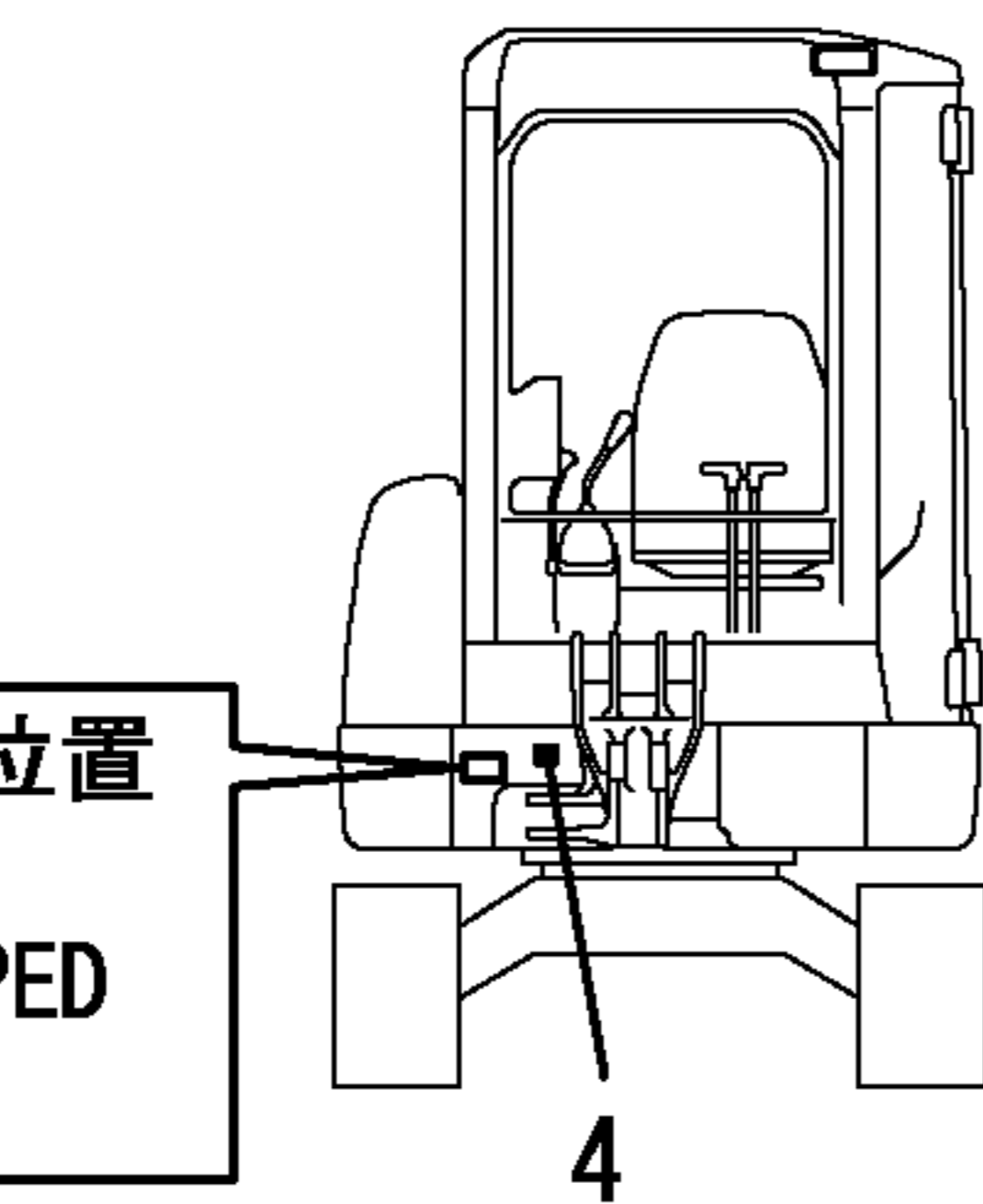
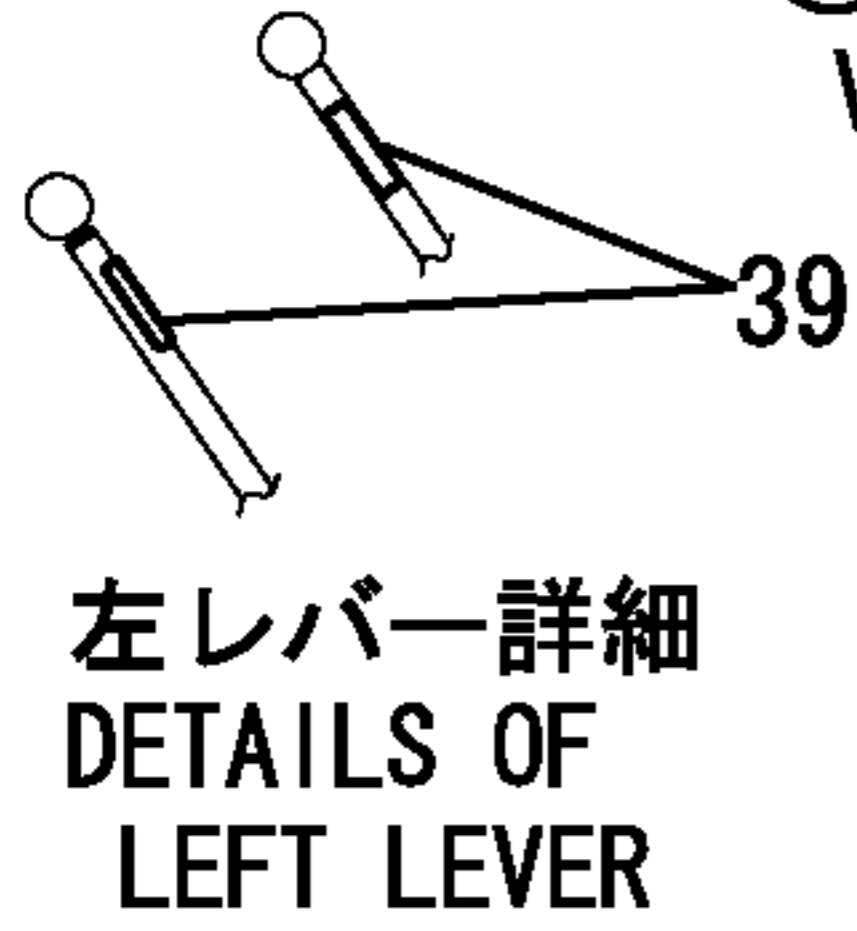
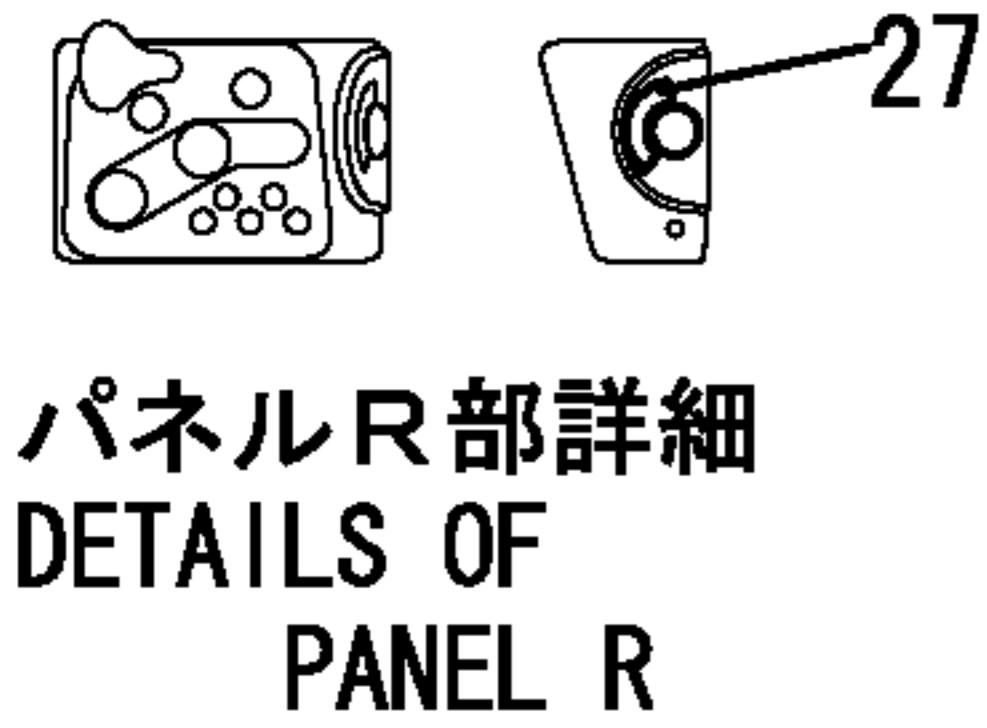
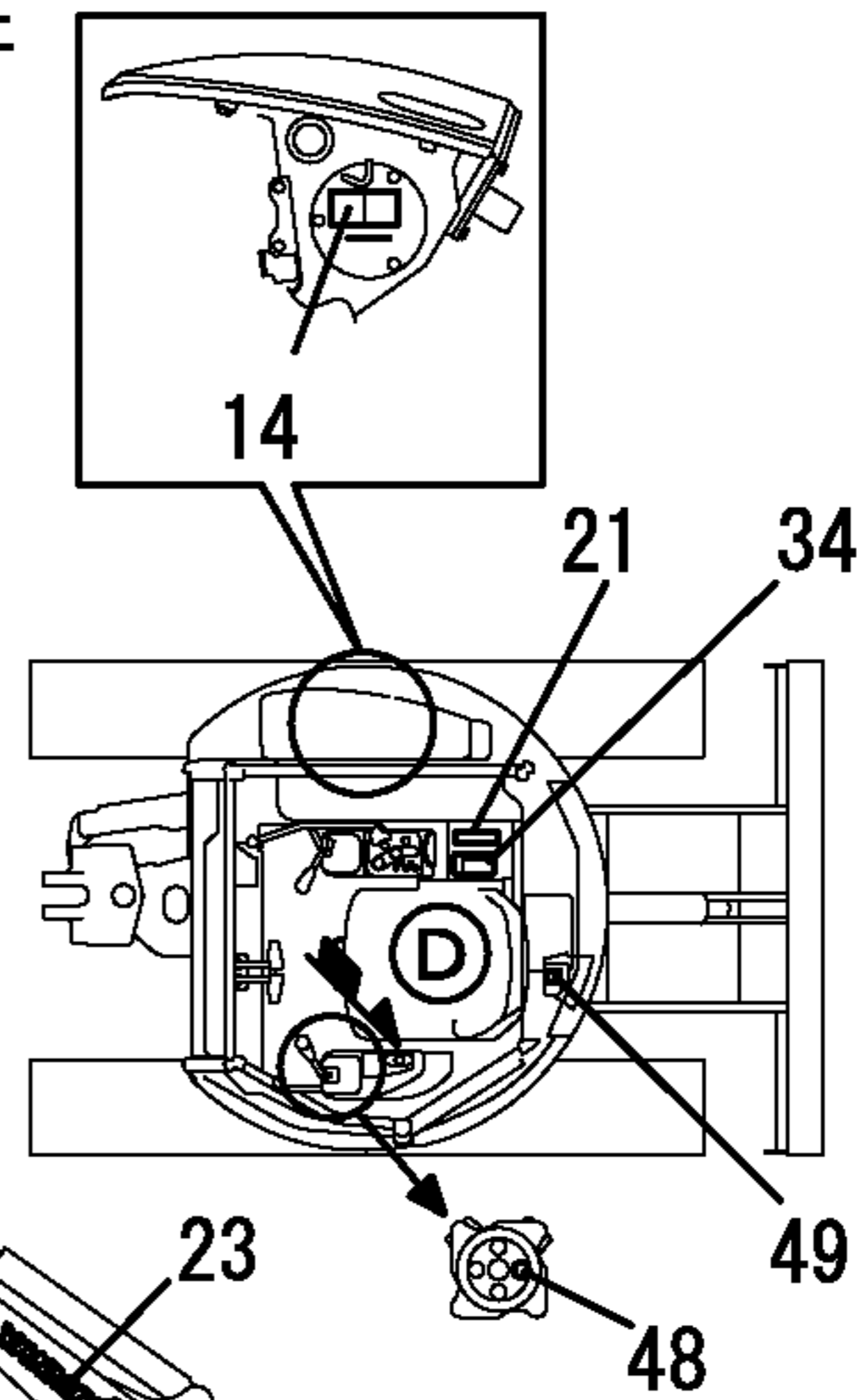
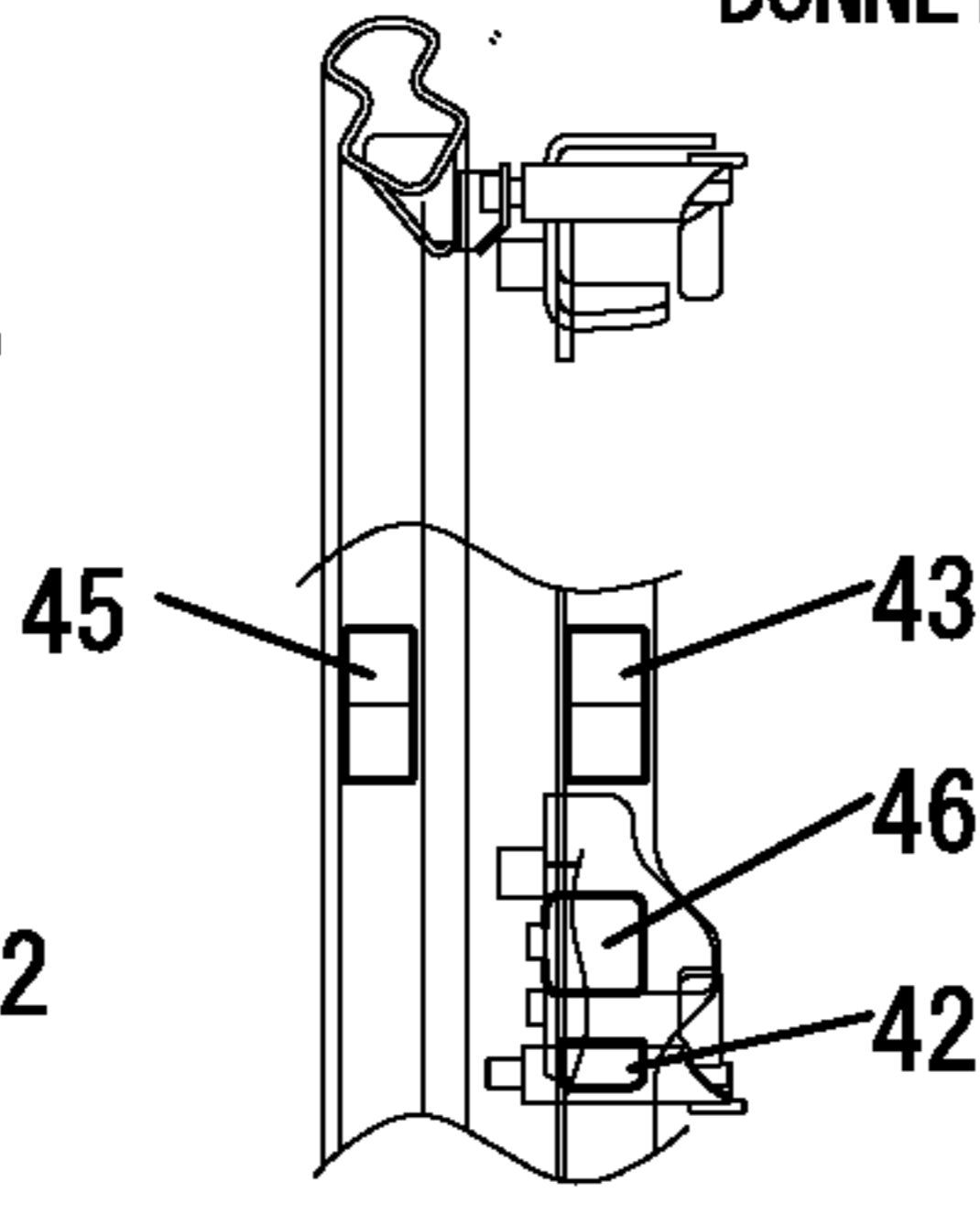
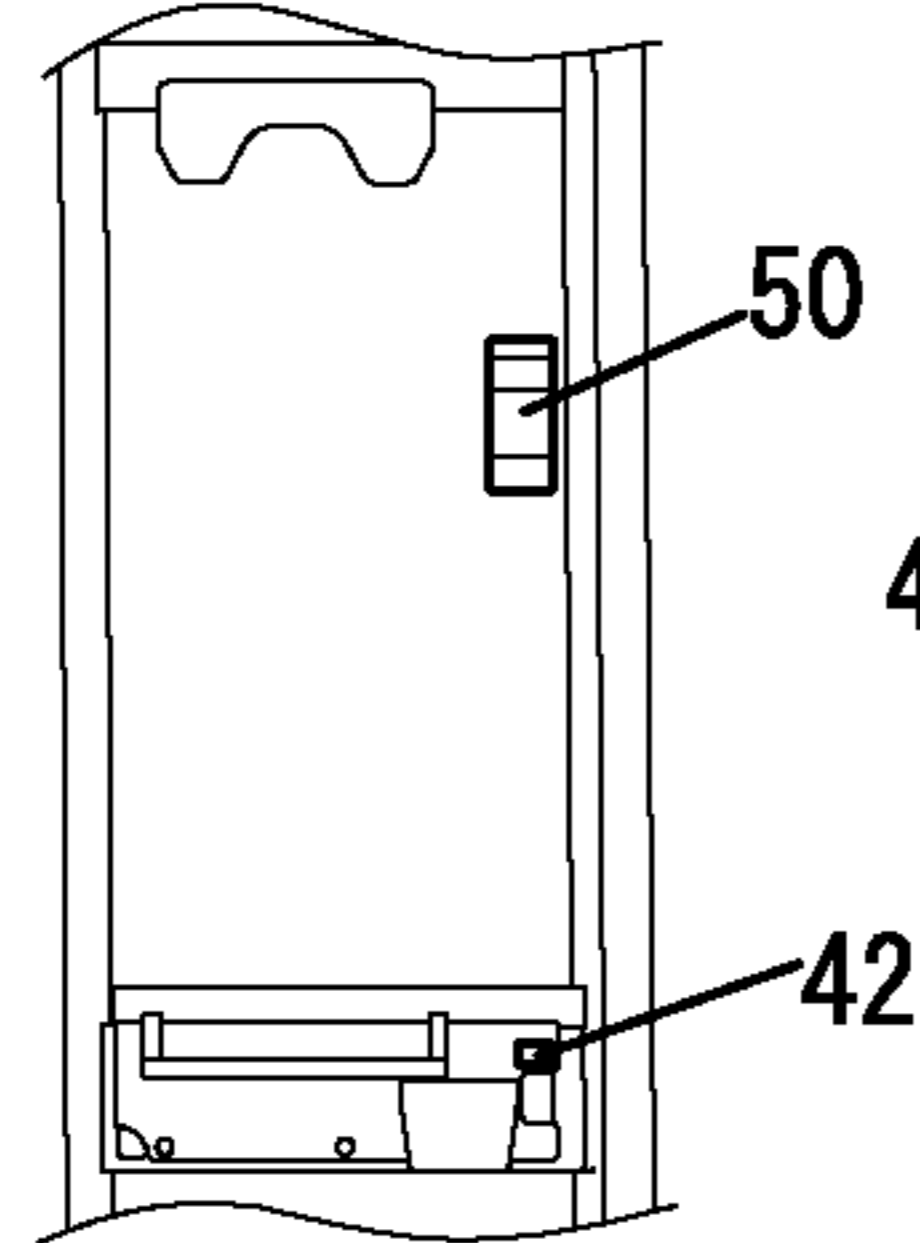
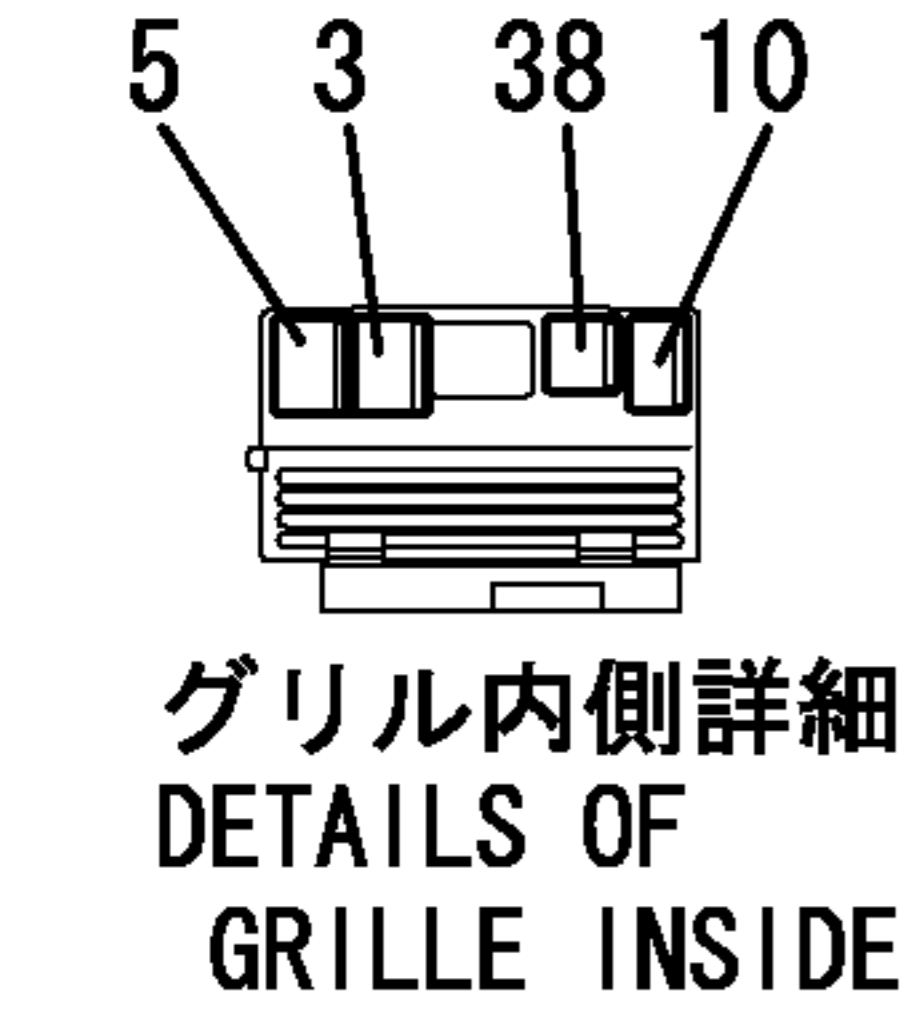
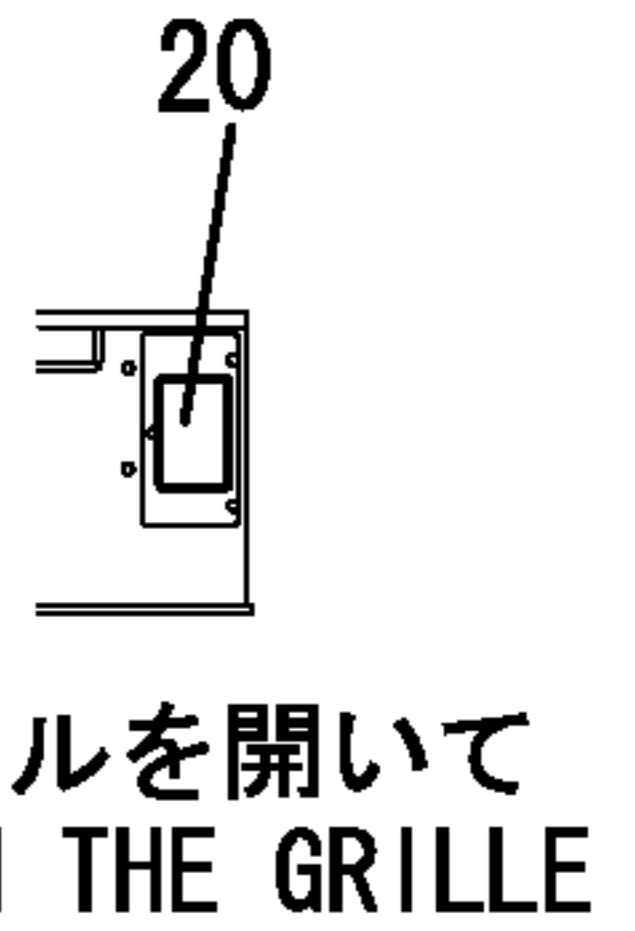
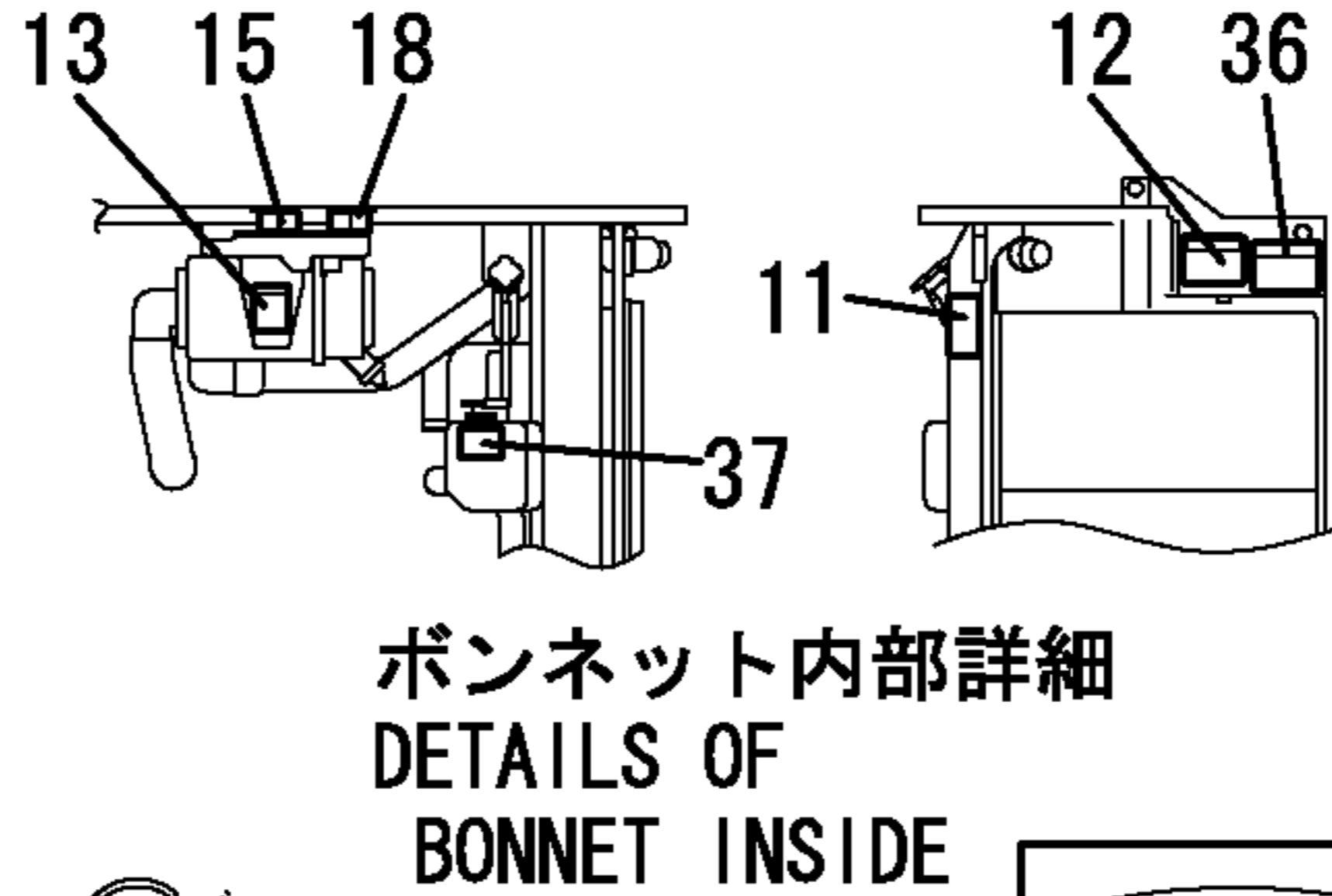
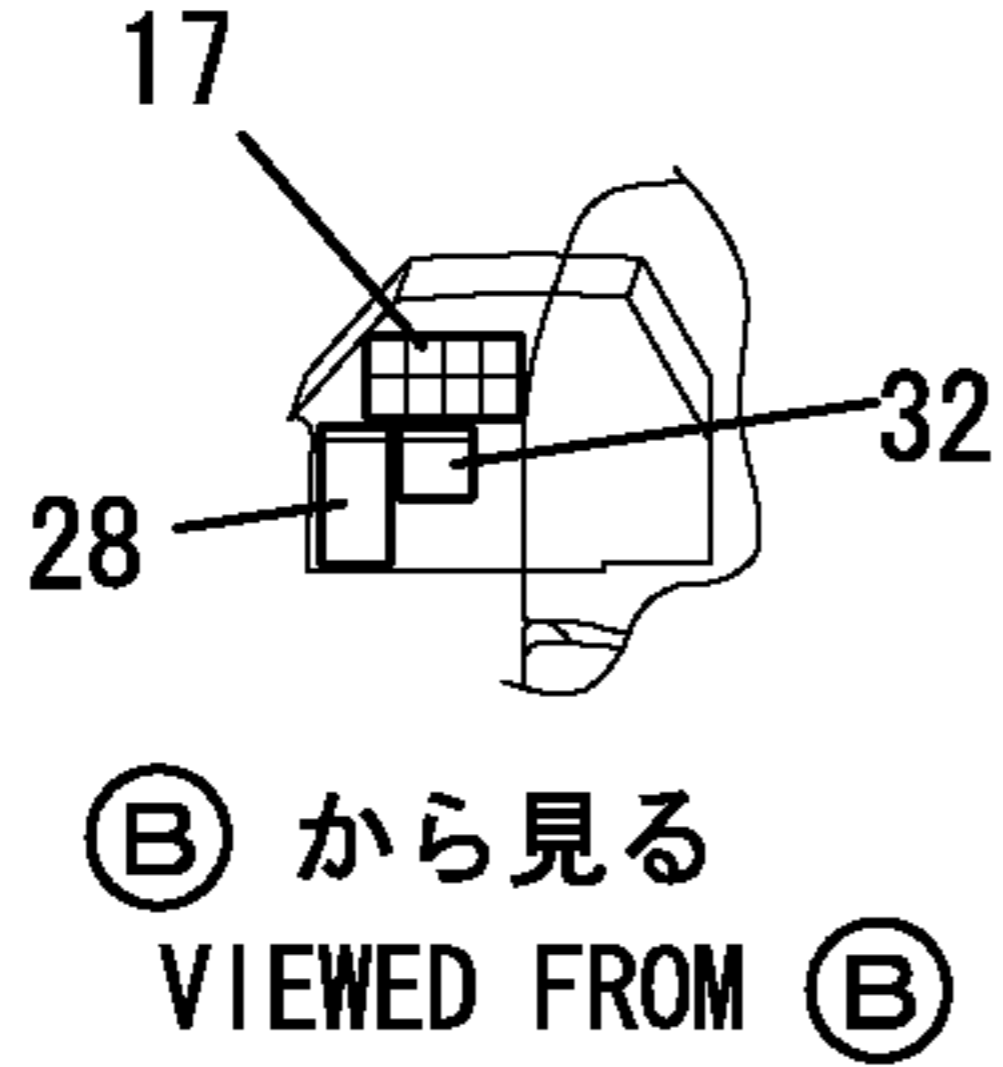
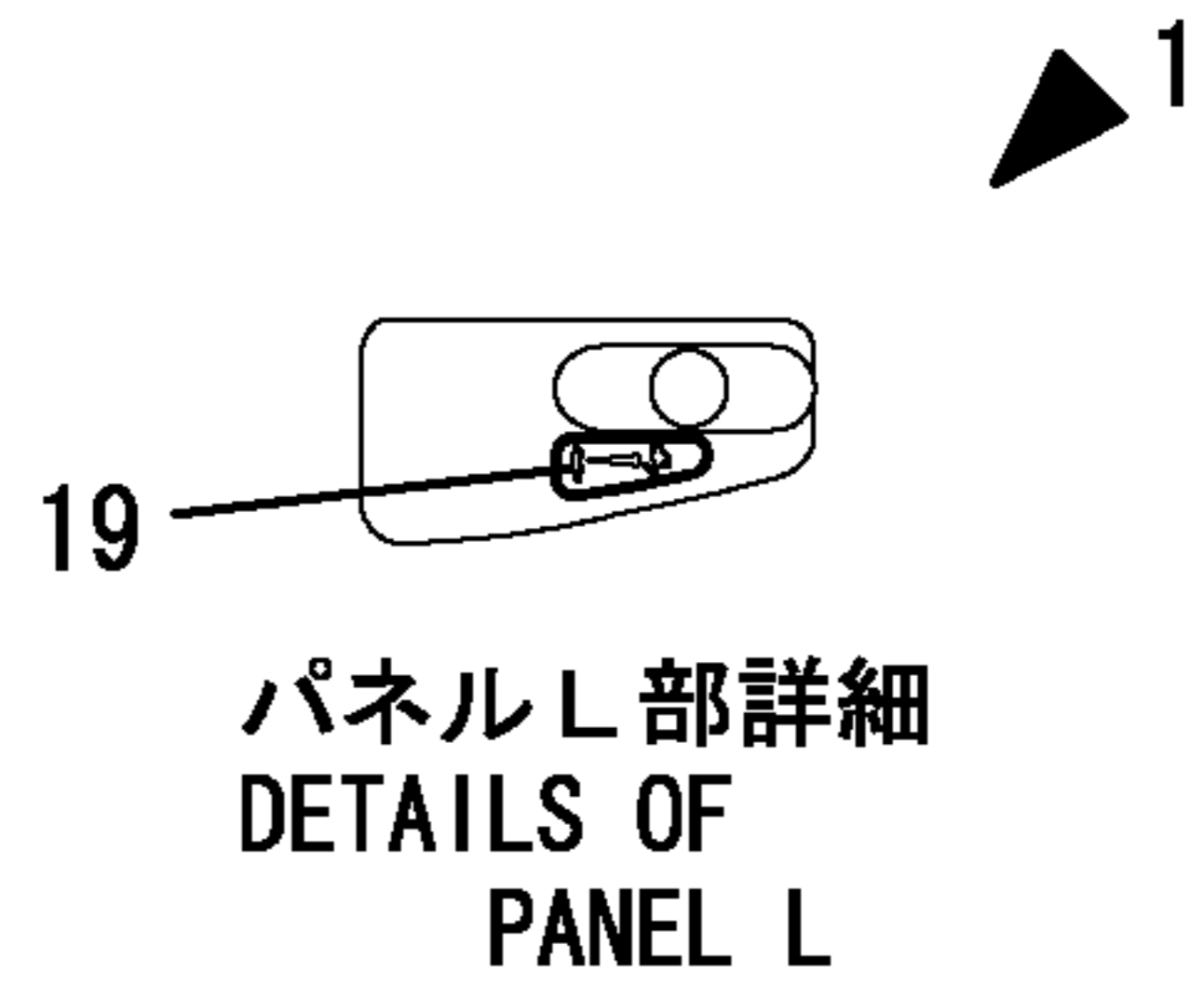
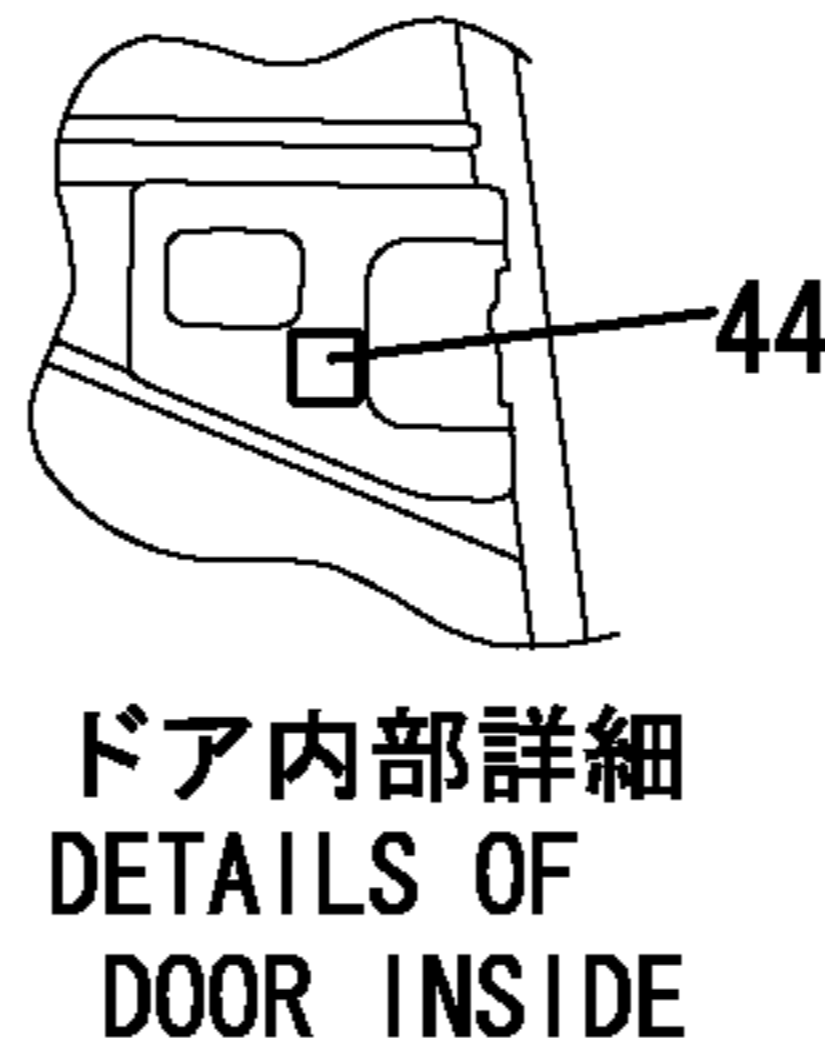
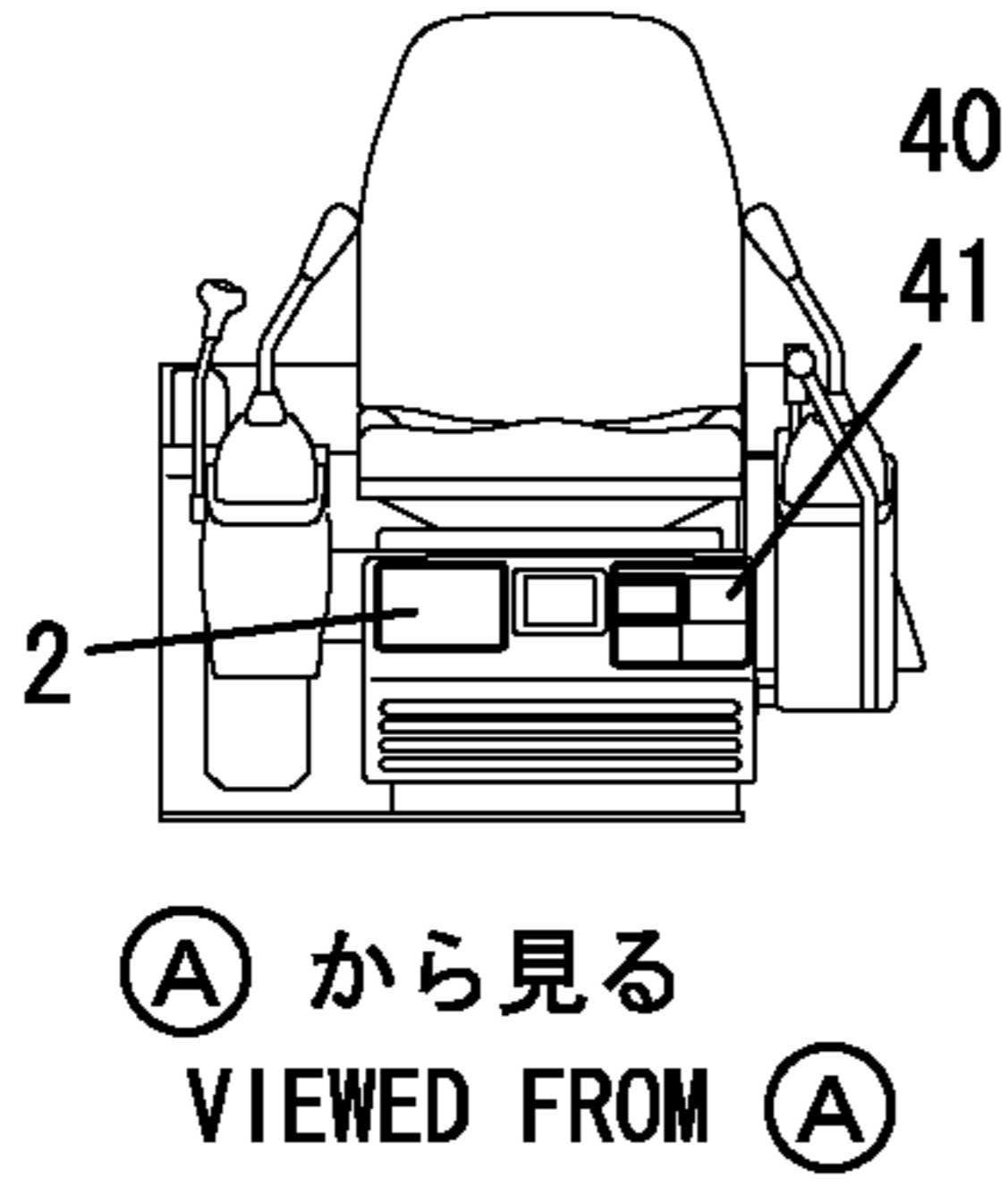
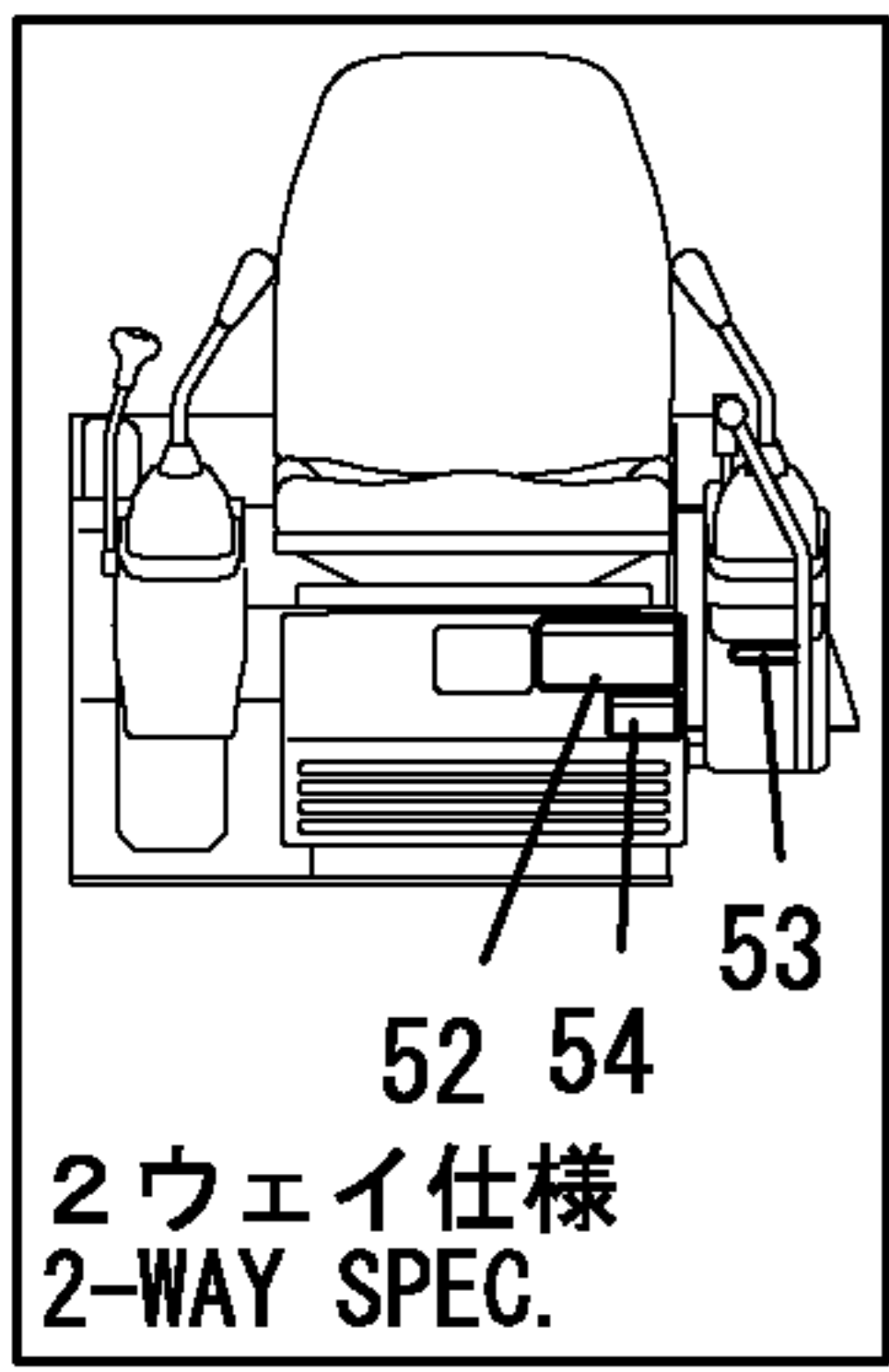

取説収納庫在中  
IN THE OPERATION  
MANUAL CASE

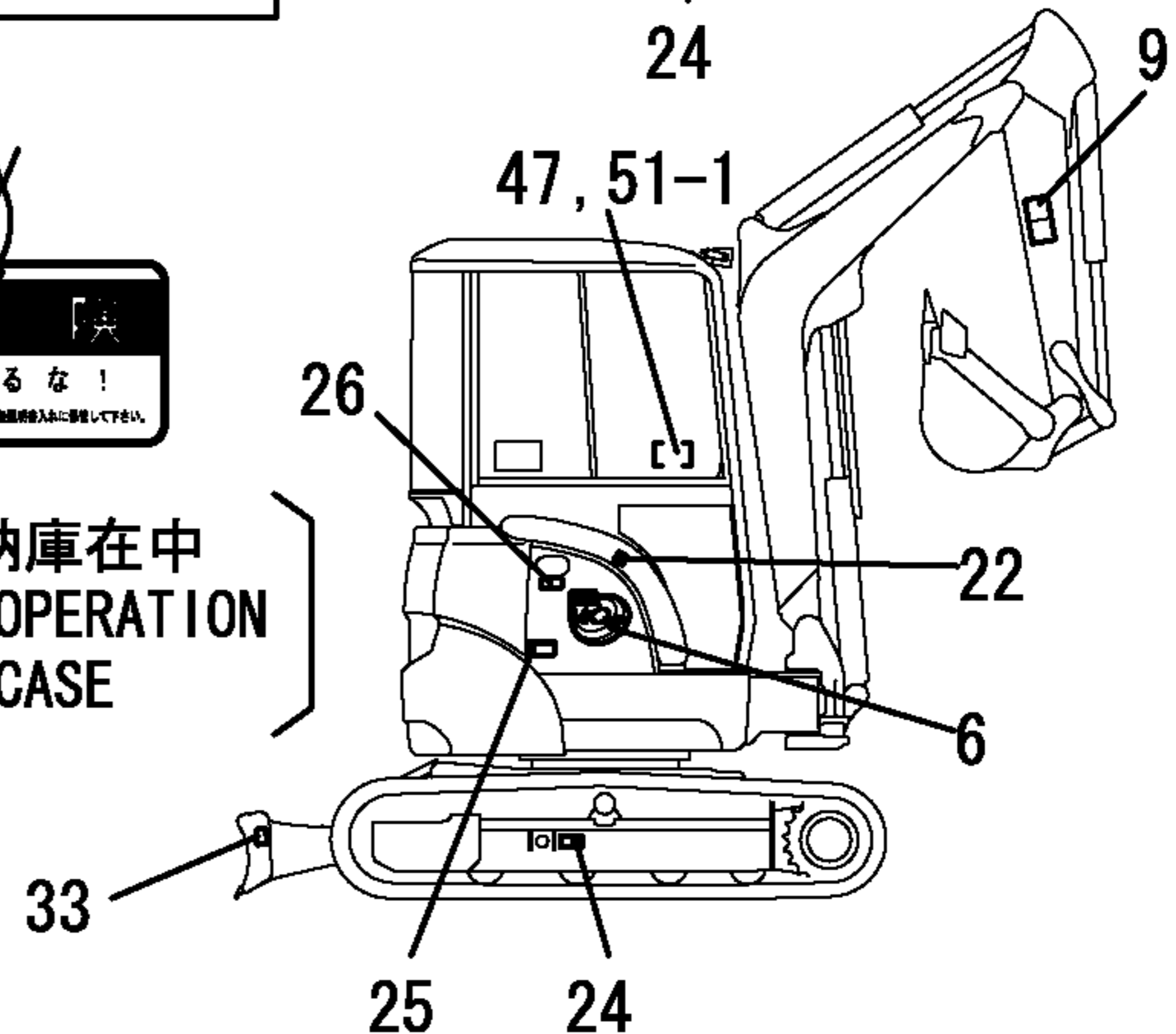

機体No. 機関No. 打刻位置  
MACHINE SERIAL No.  
ENGINE No. IS STAMPED  
INTO THIS LOCATION.

機体No. 打刻位置  
MACHINE SERIAL No.  
IS STAMPED INTO  
THIS LOCATION.

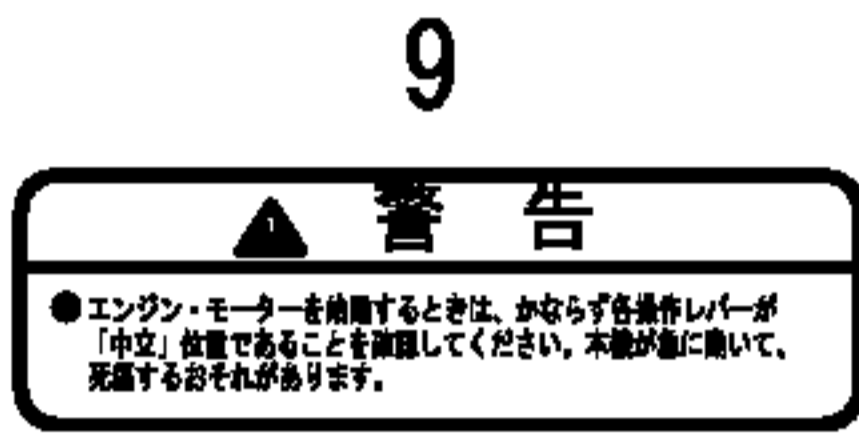
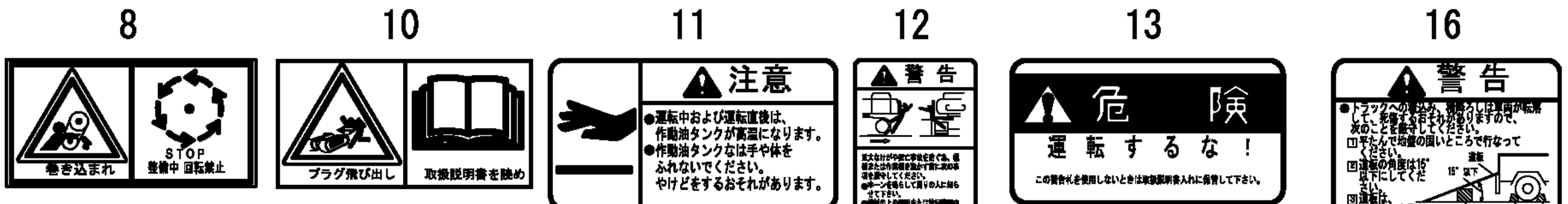
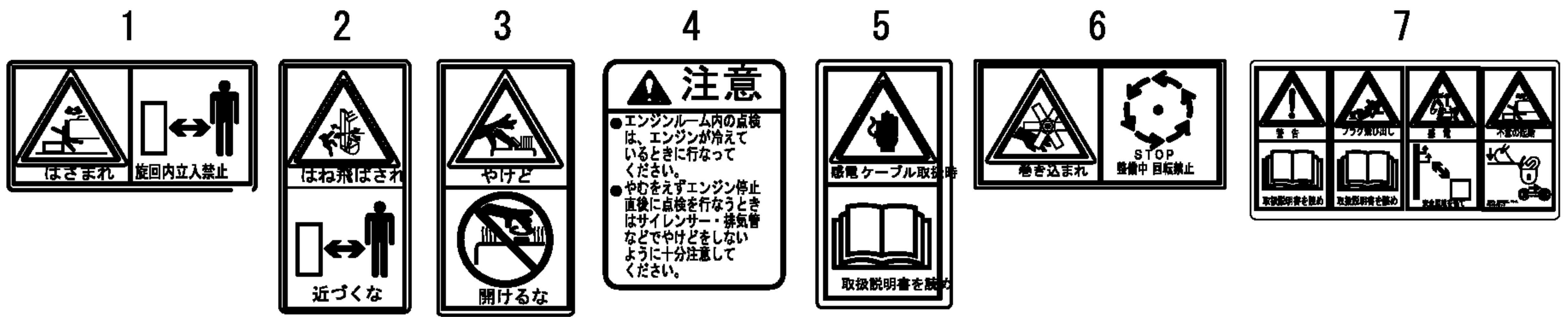

取説収納庫在中  
IN THE OPERATION  
MANUAL CASE

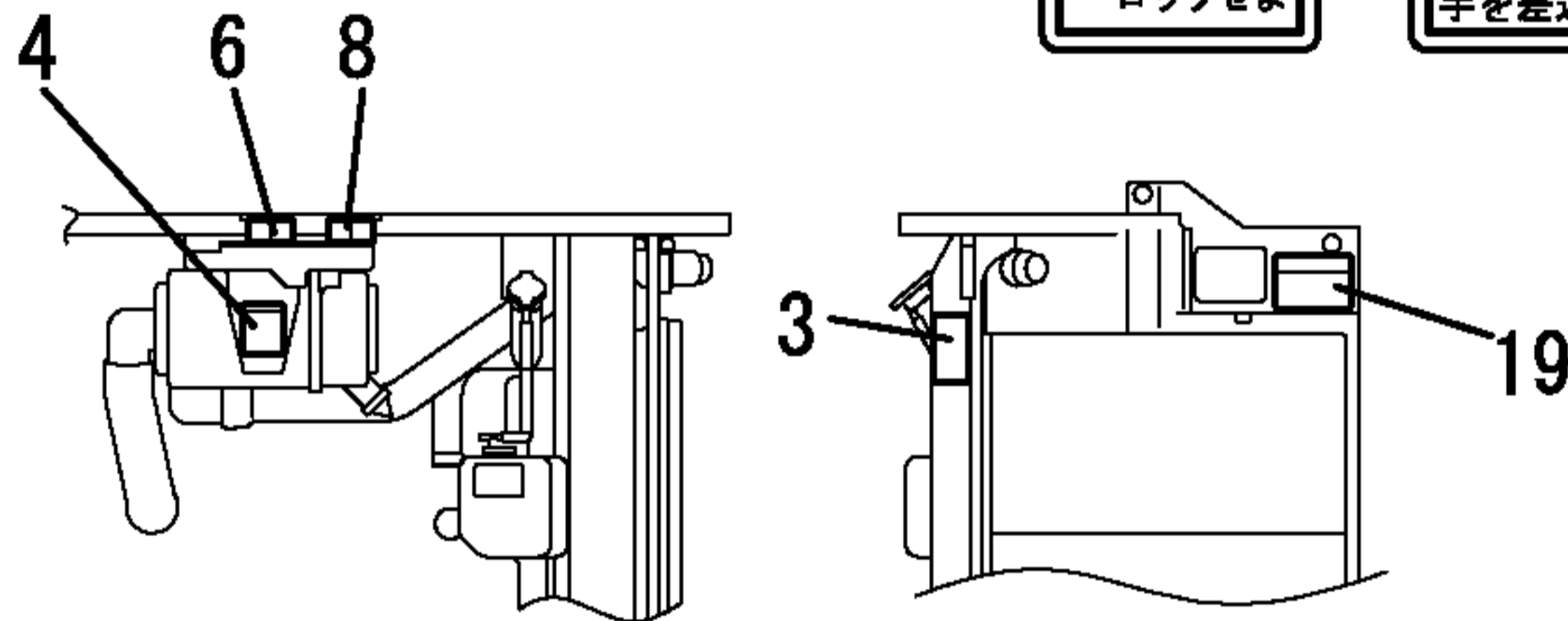
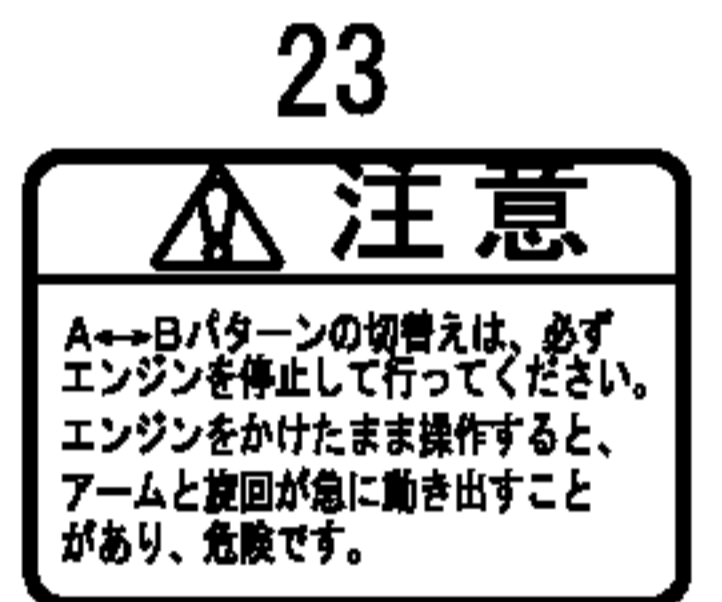
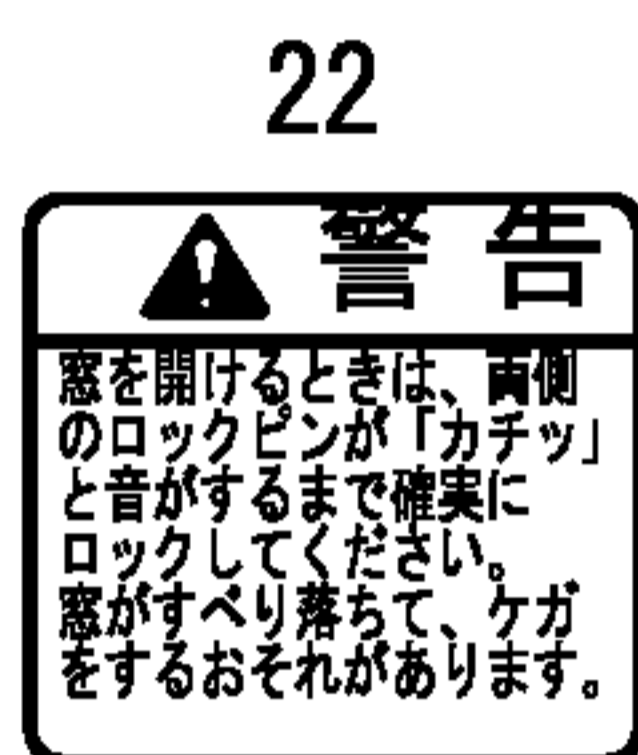
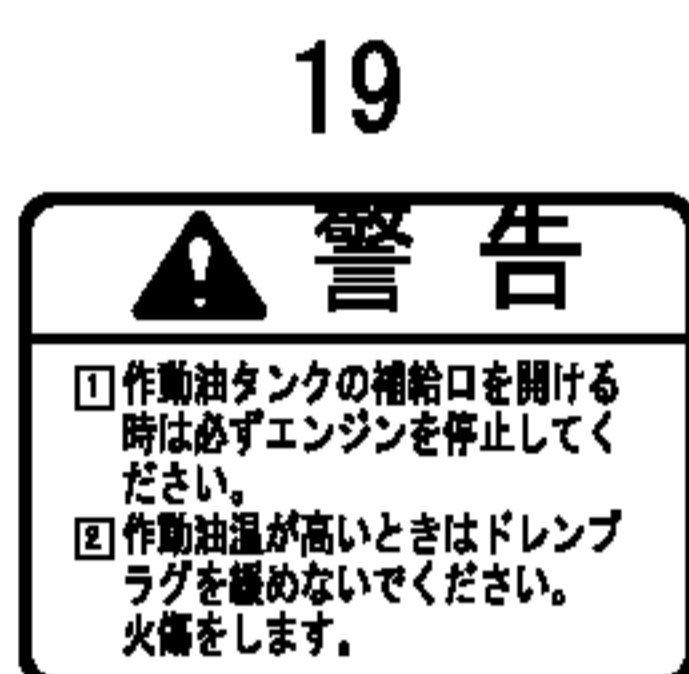
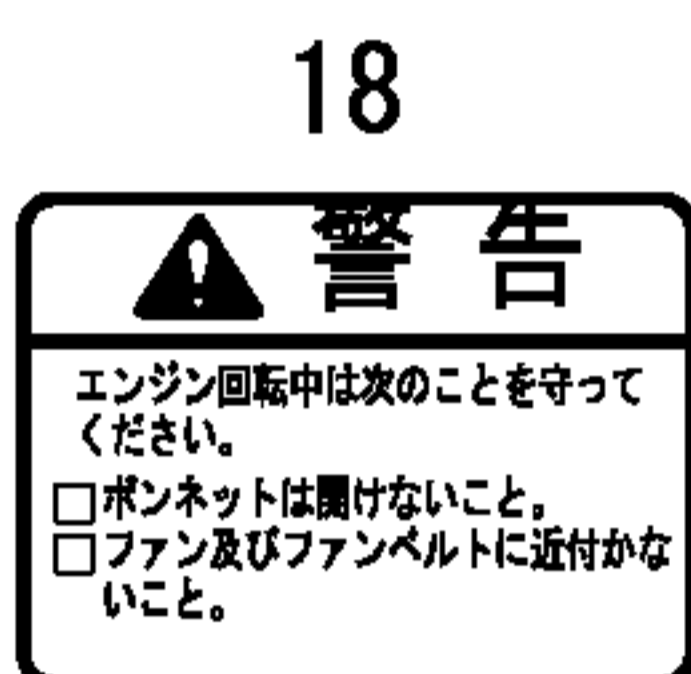
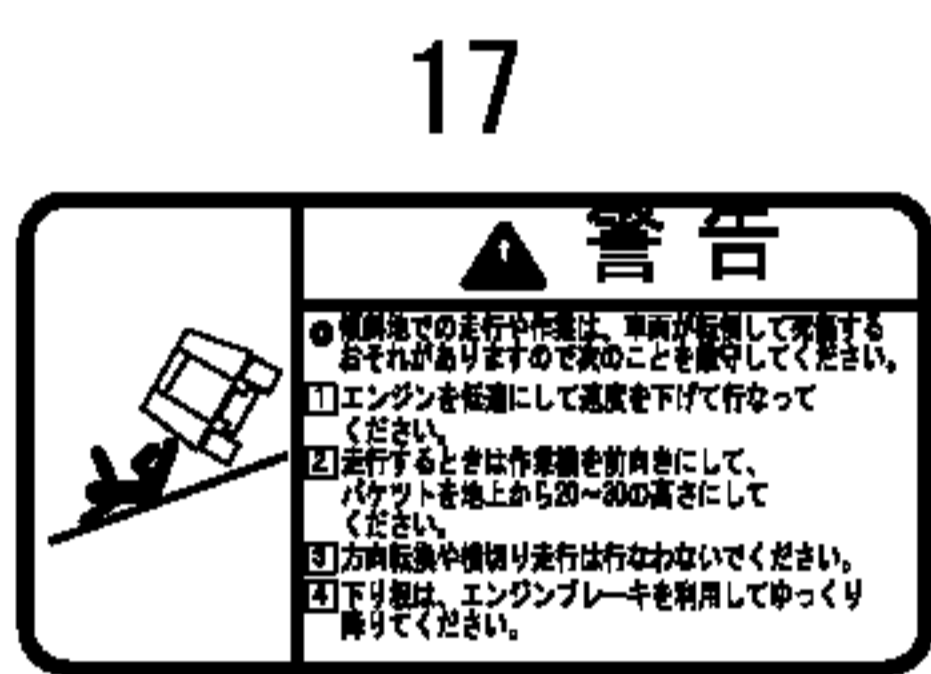

ボンネット内部詳細  
DETAILS OF  
BONNET INSIDE

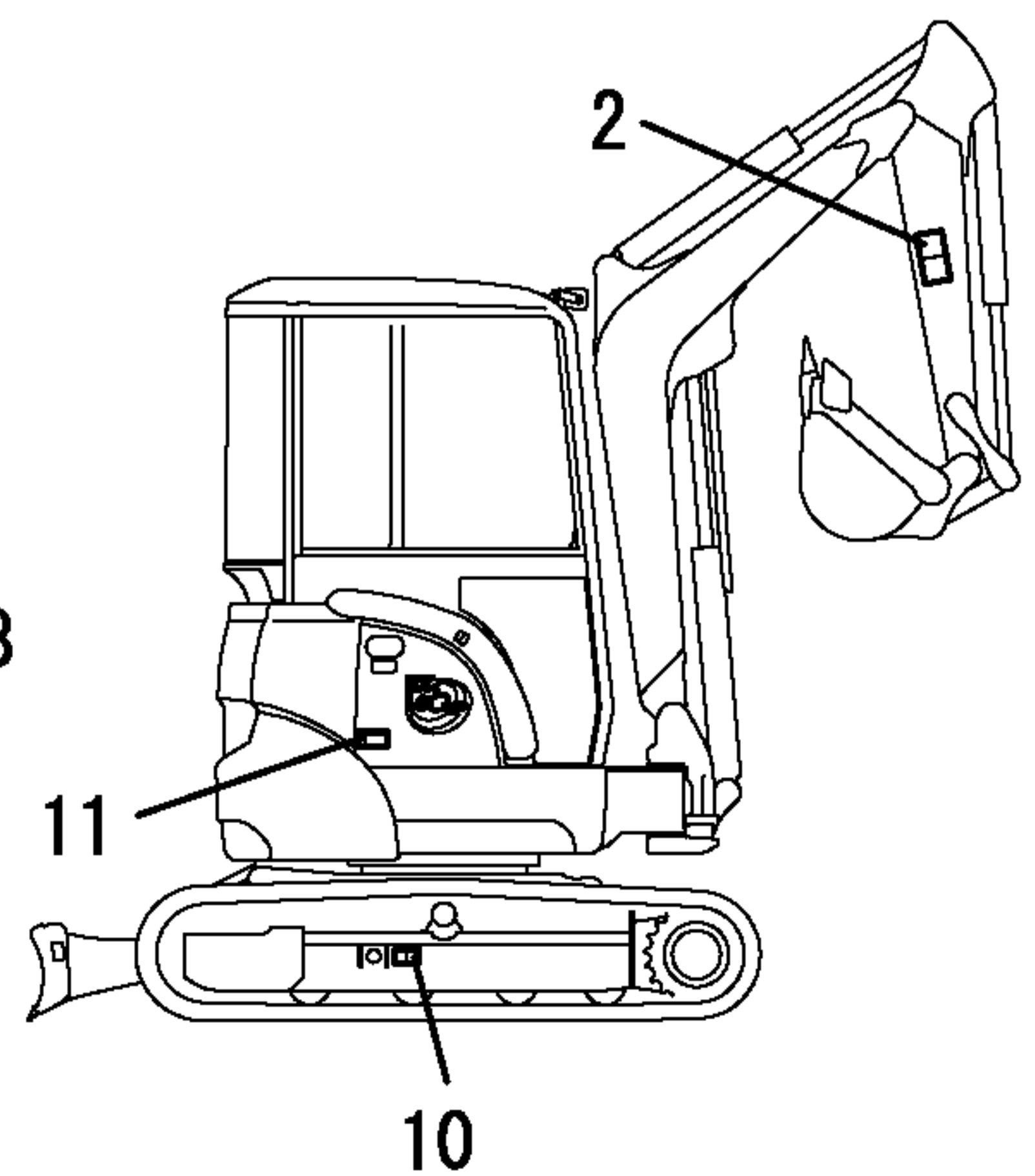
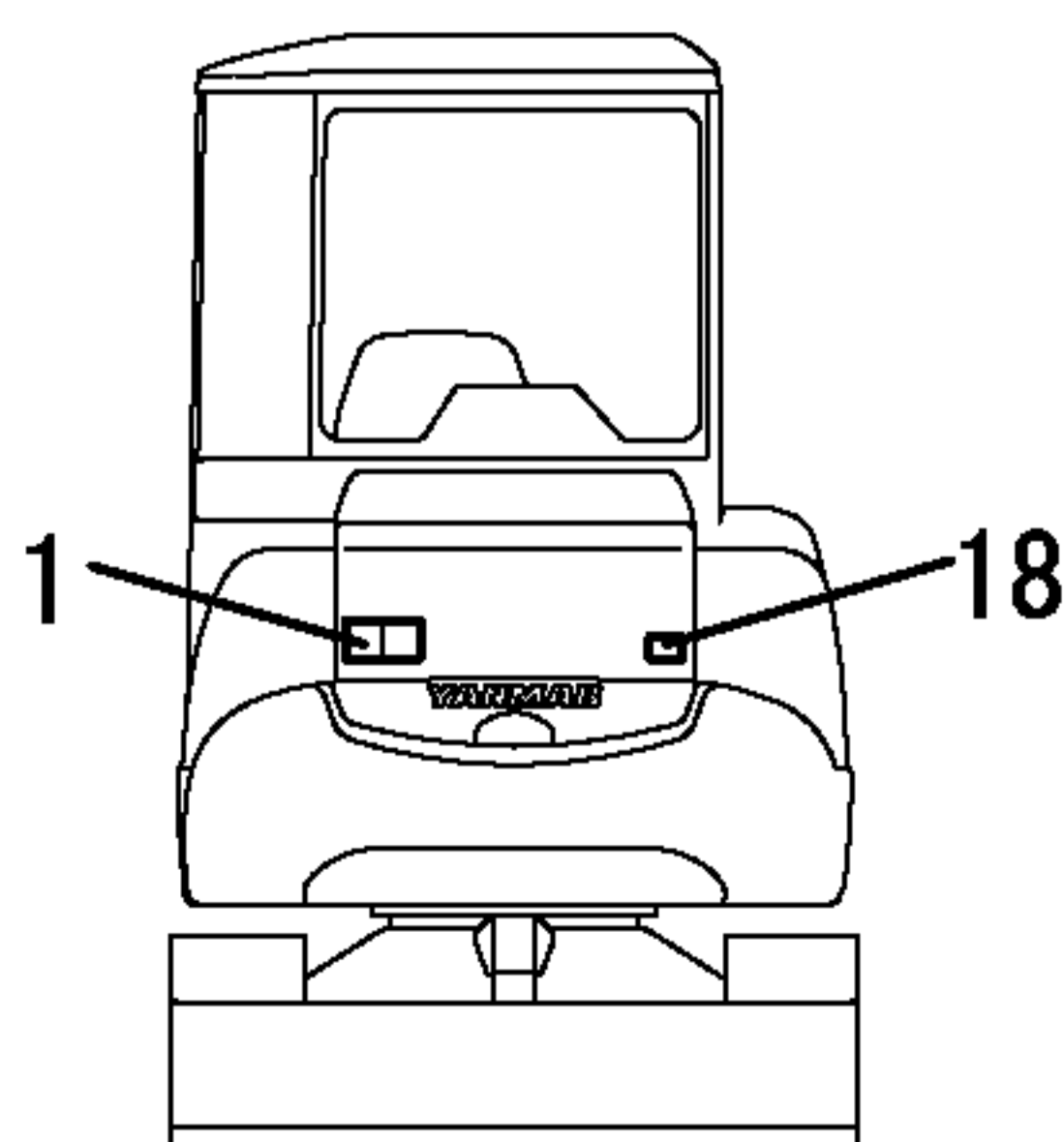
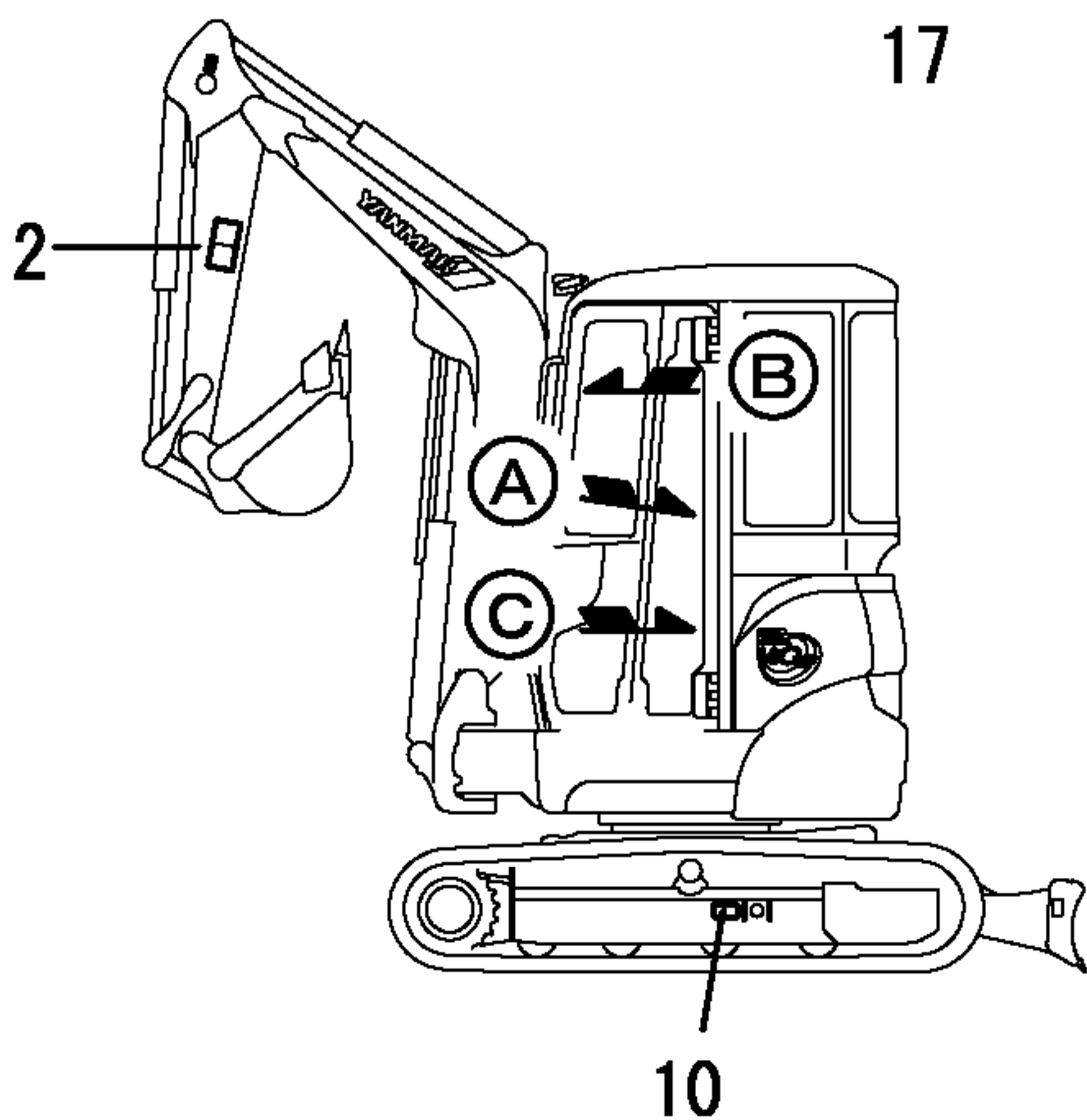
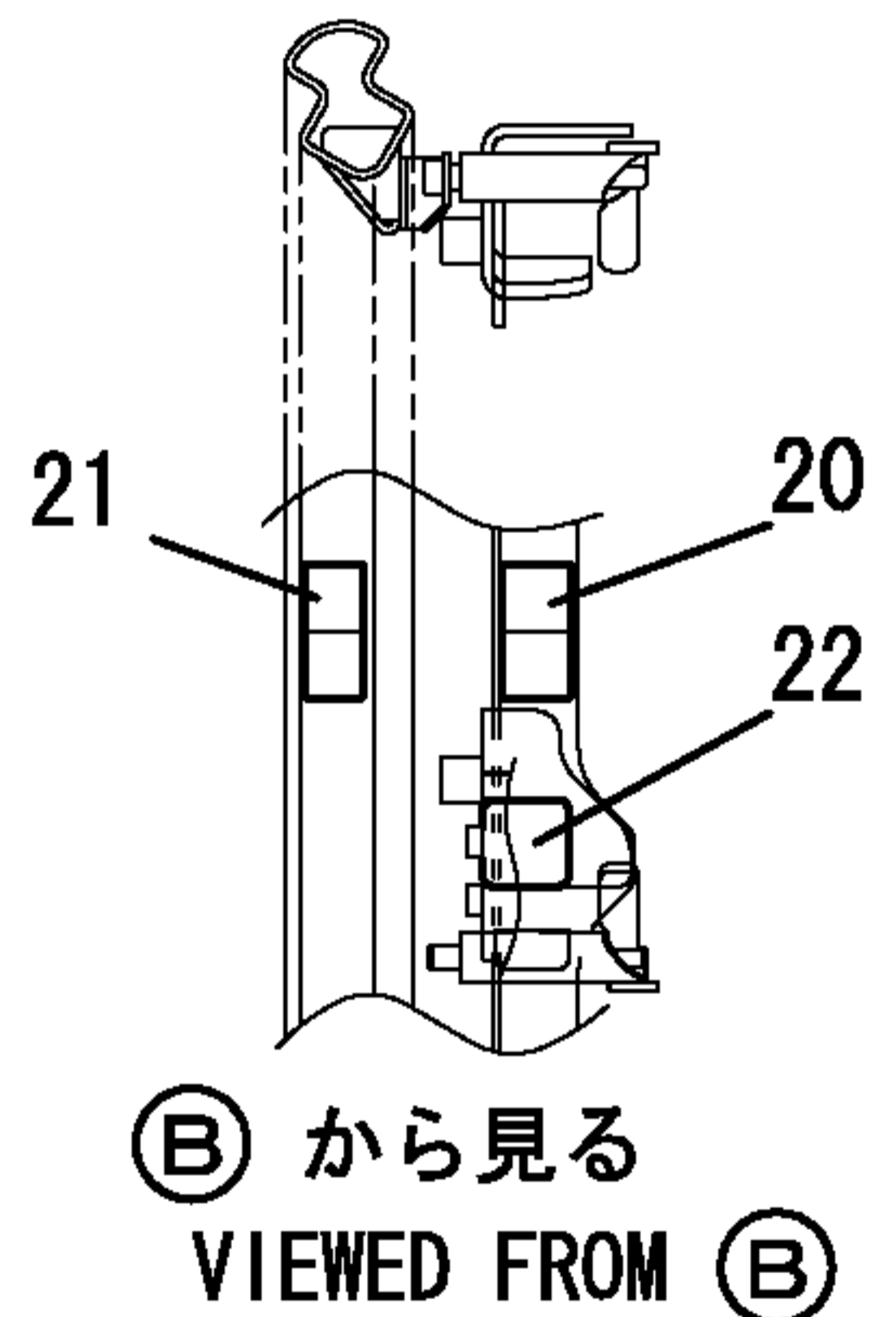
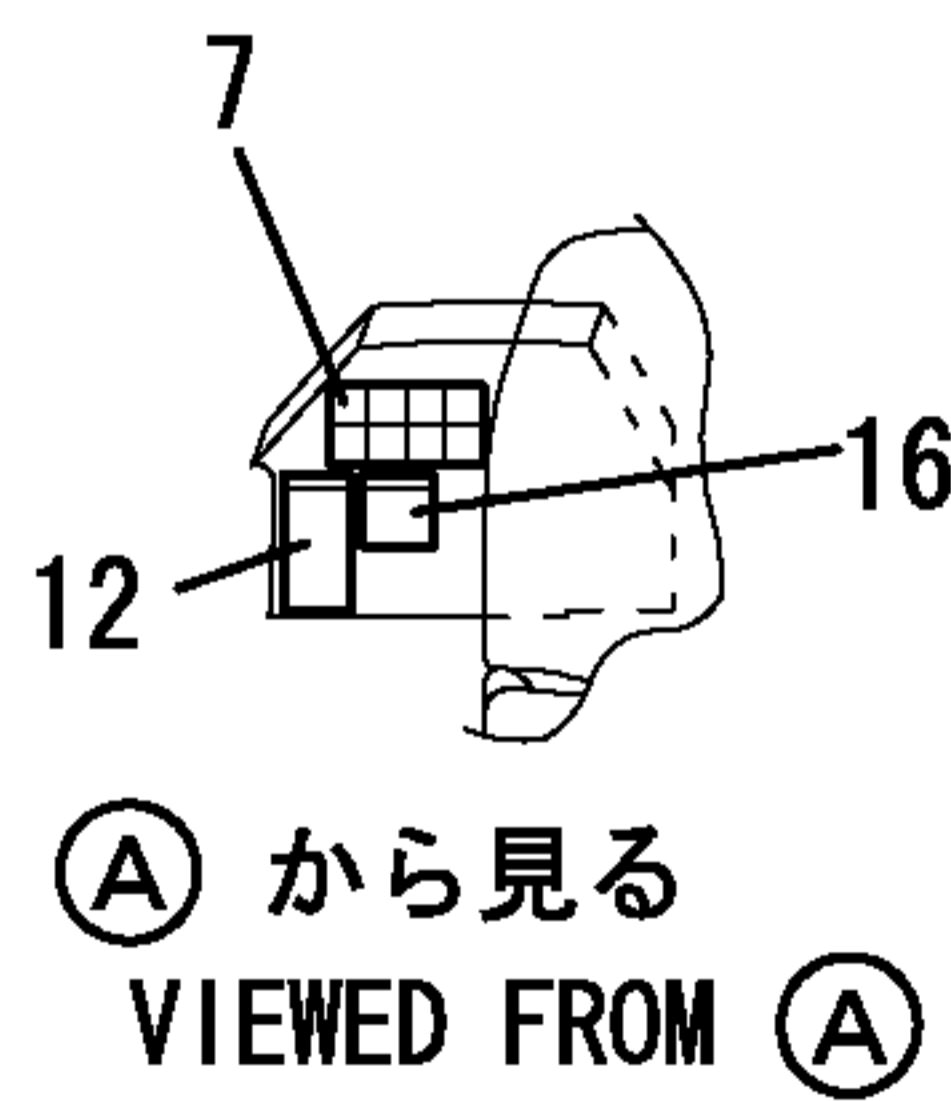
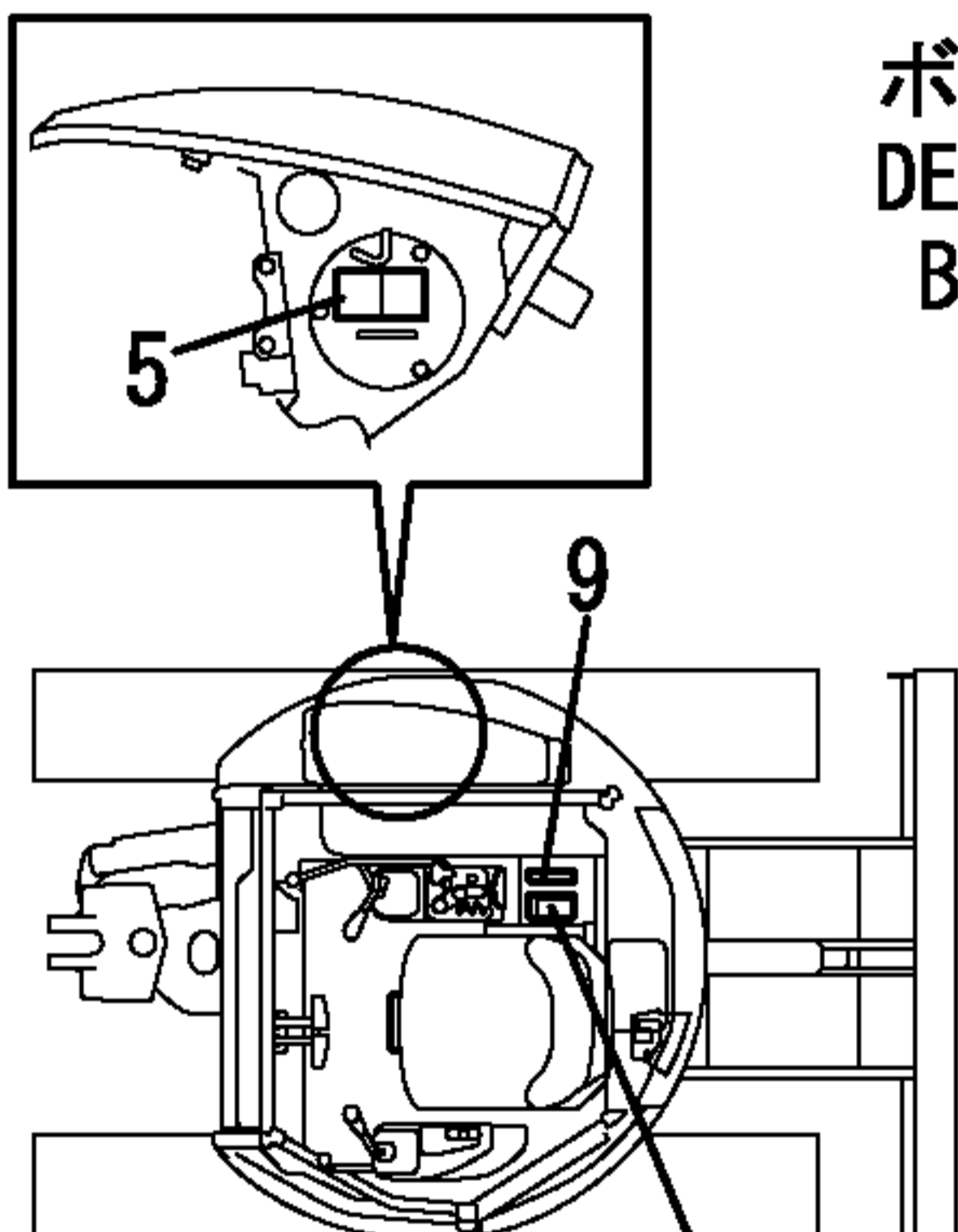
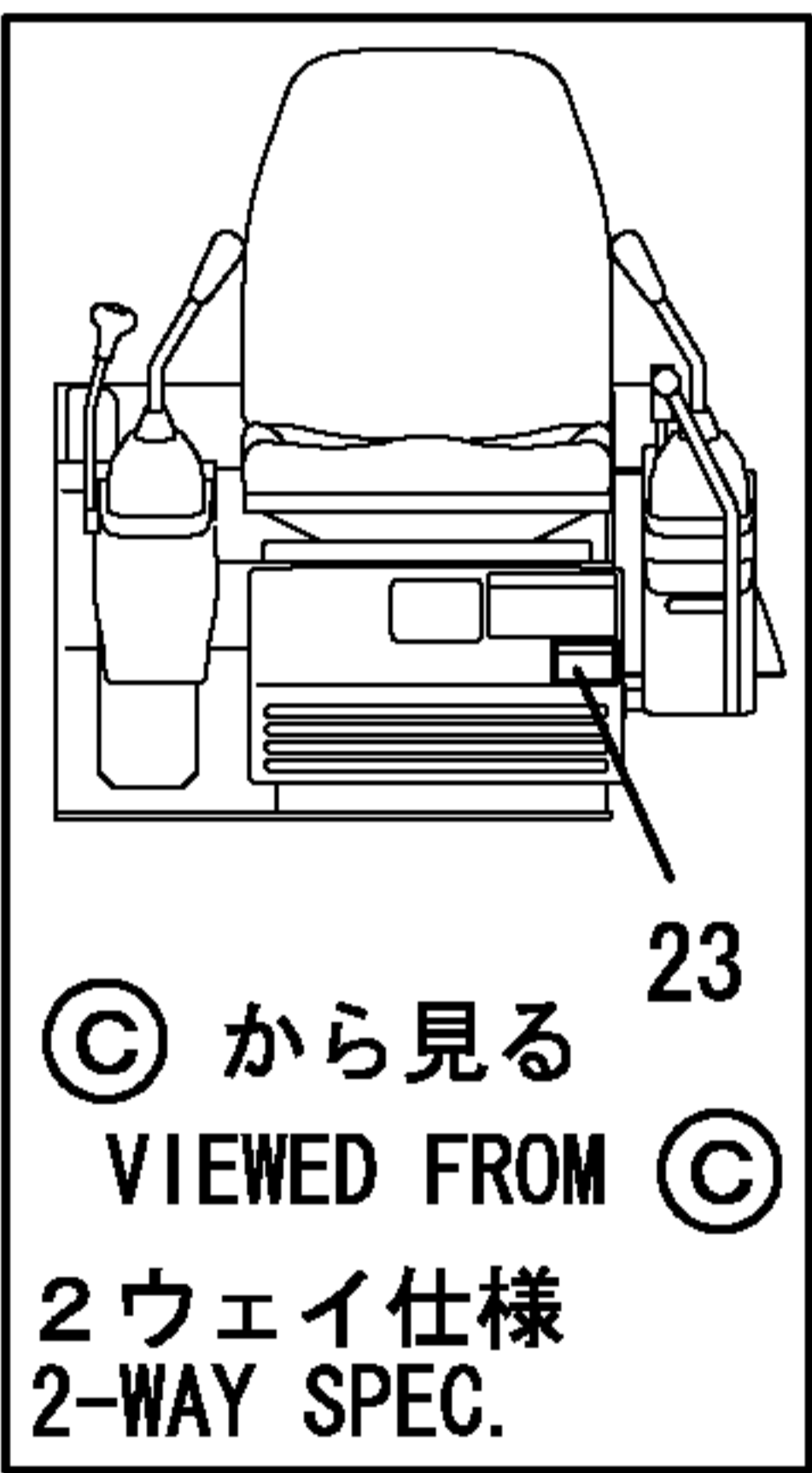

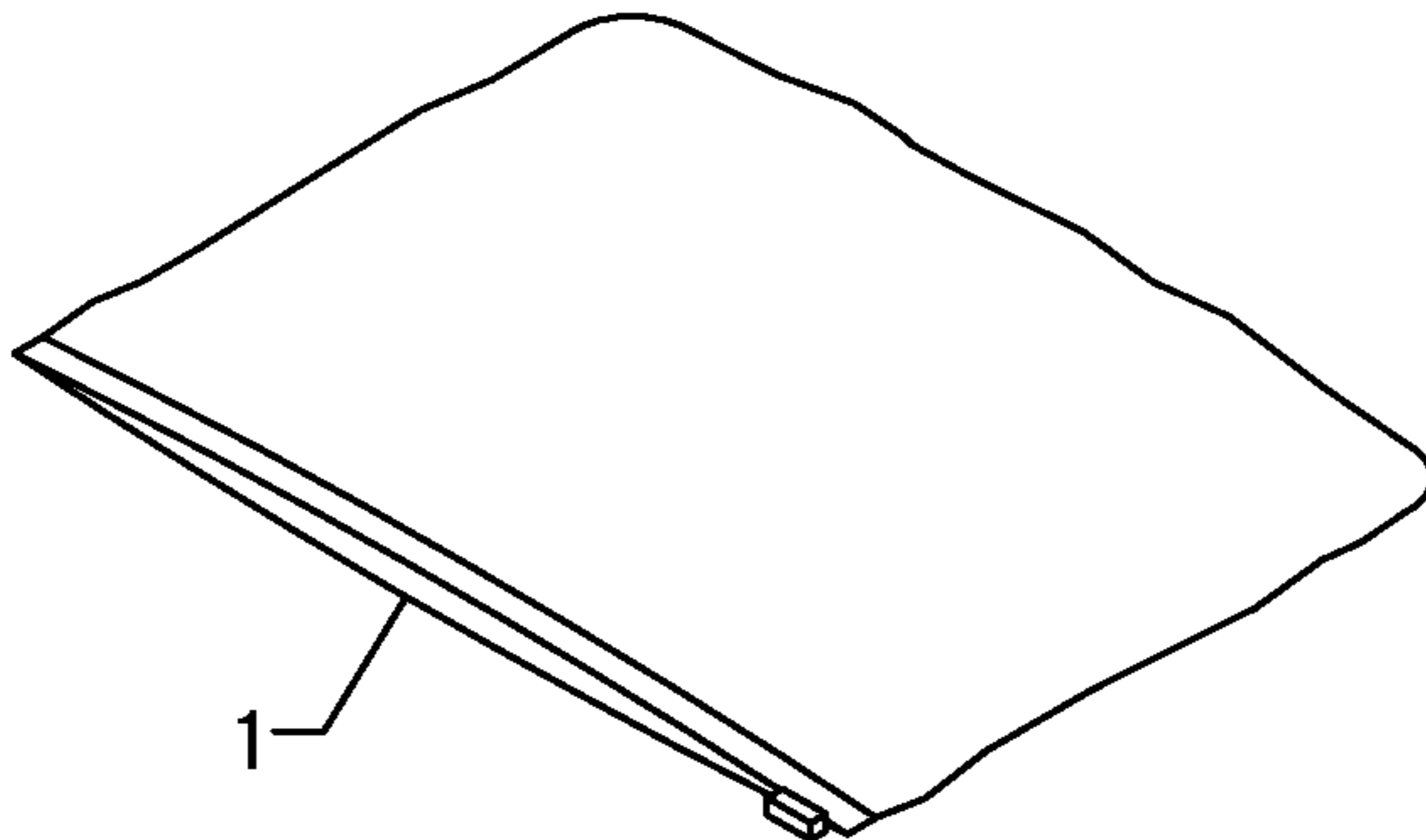

REFER TO  
Fig. 55~60

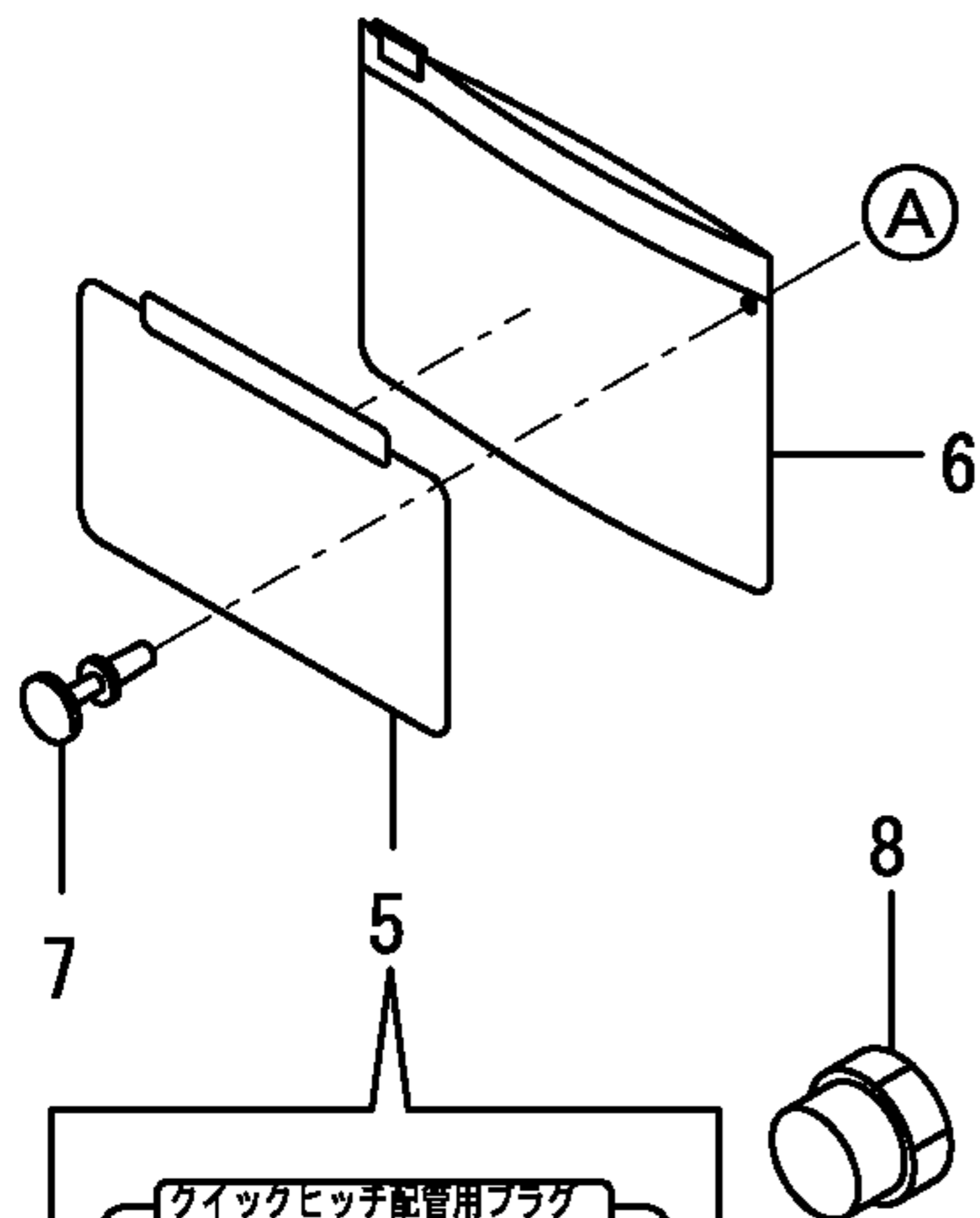
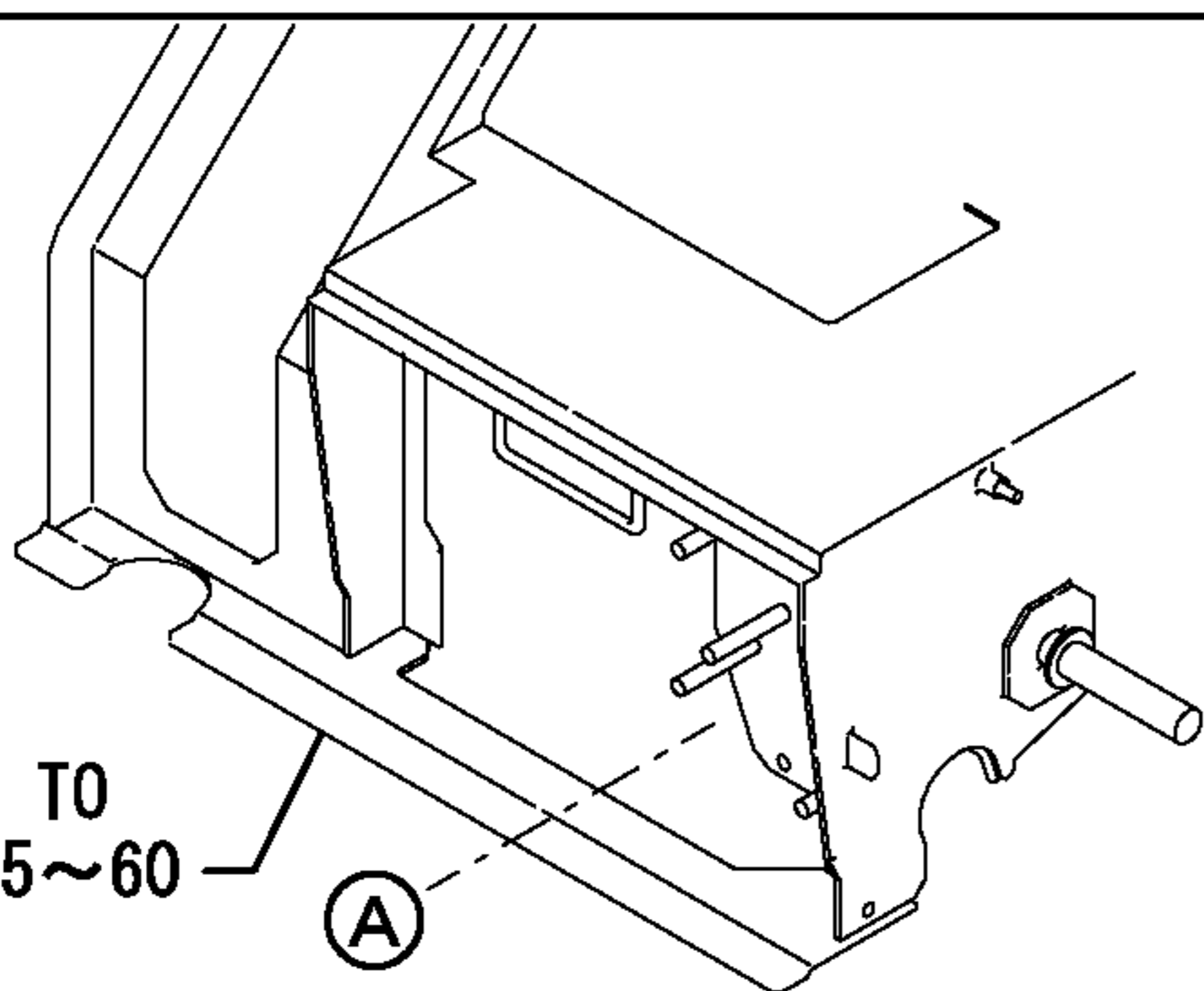

**クイックヒッチ配管用プラグ**

万一、クイックヒッチ・ホースに油もれが発生した場合、ホースを外してこの応急用プラグを取付け油もれをとめてください。

**注意**  
このプラグを装着しての長時間の作業は行わないでください。速やかに油圧ホースを交換して下さい。

クイックヒッチ仕様  
QUICK HITCH SPEC.

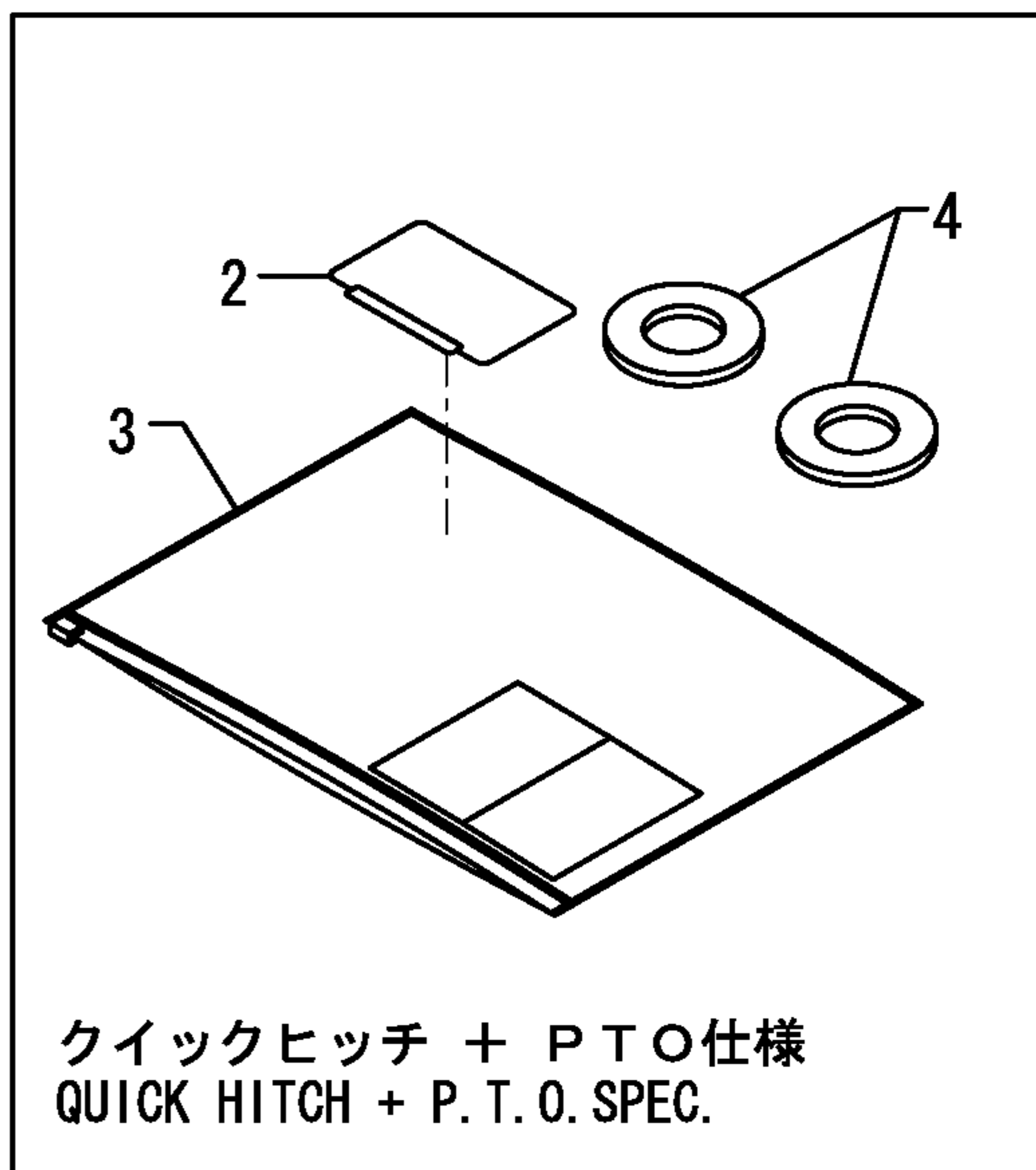

クイックヒッチ + PTO仕様  
QUICK HITCH + P. T. O. SPEC.

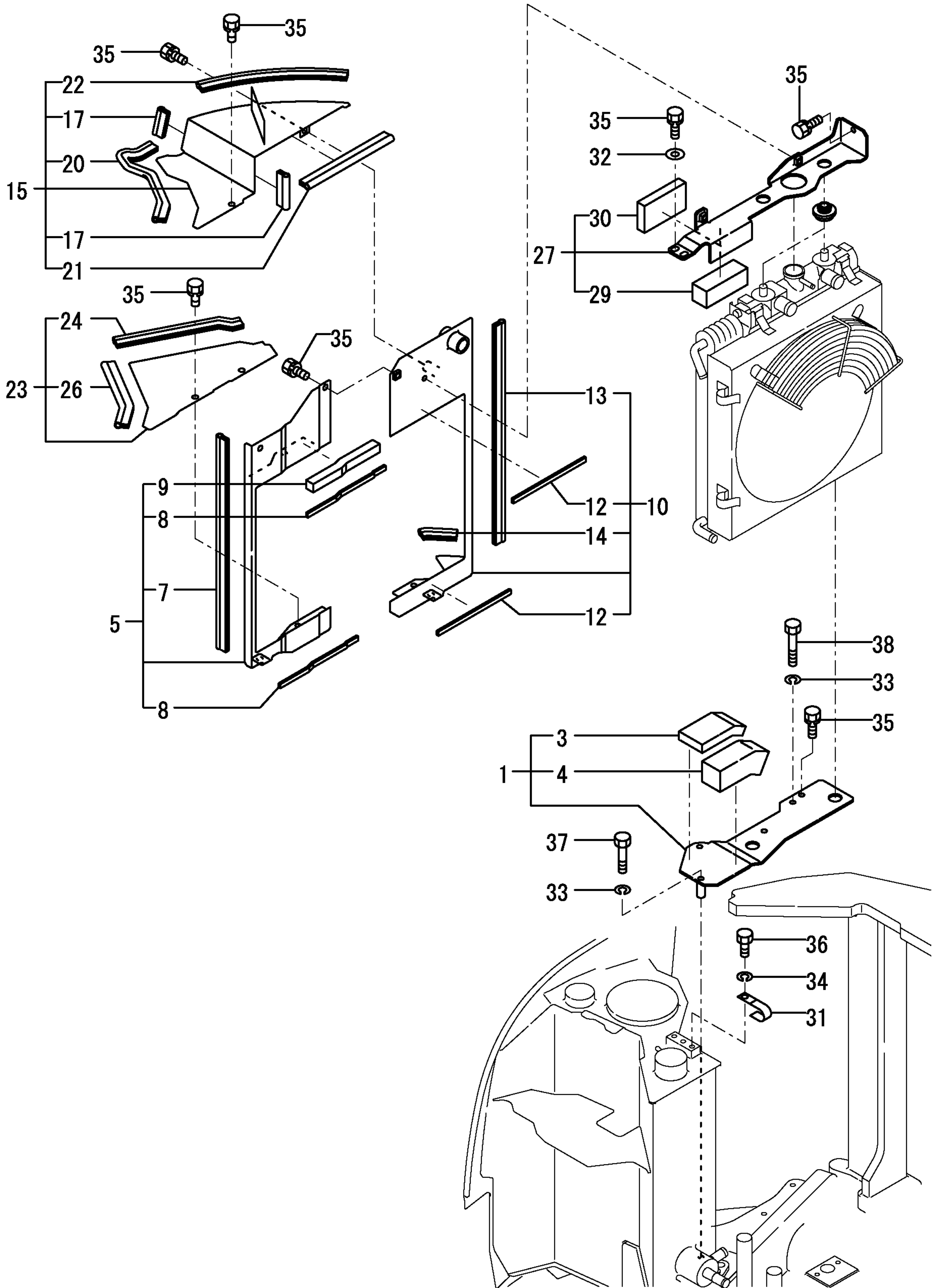

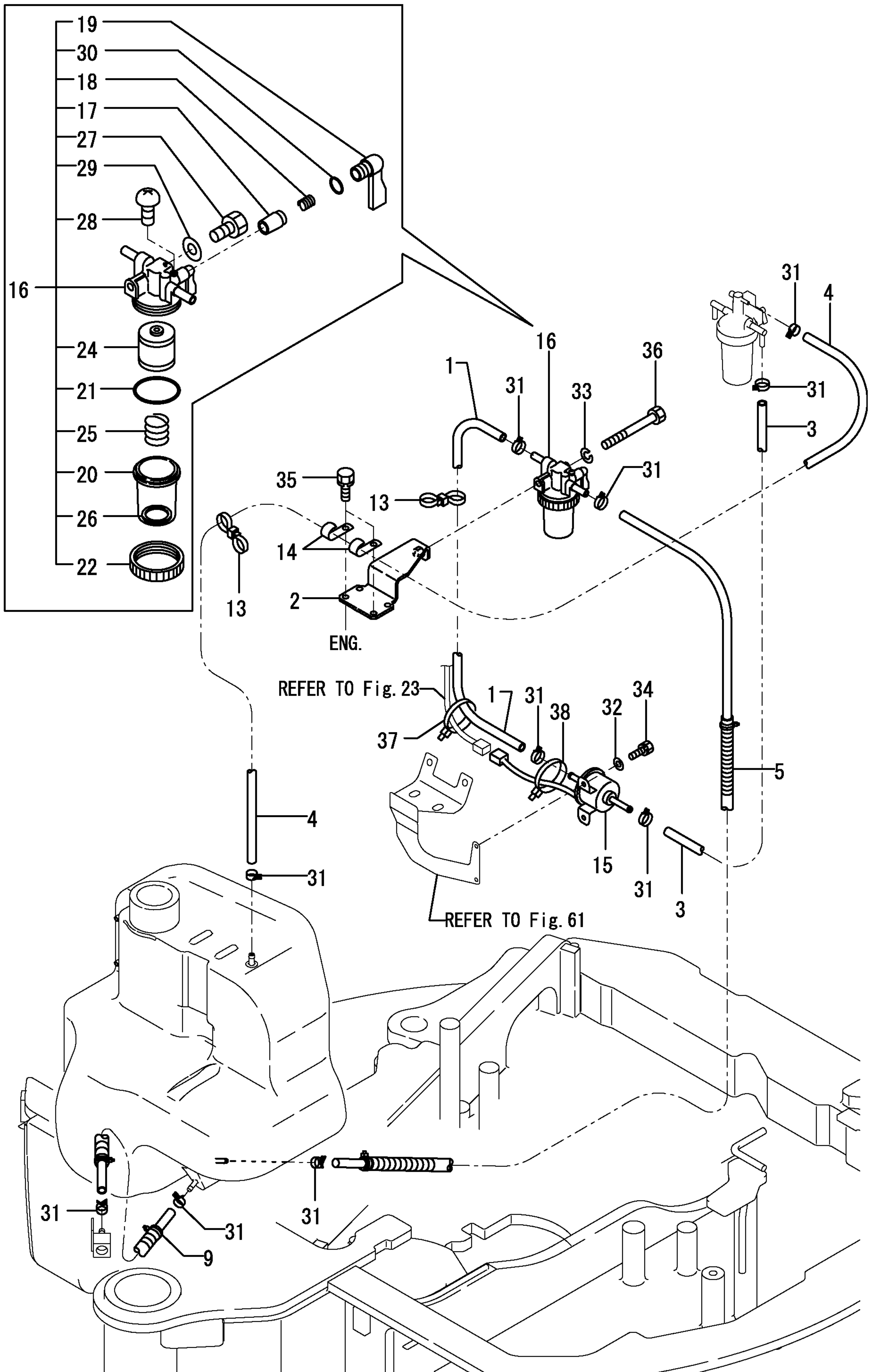

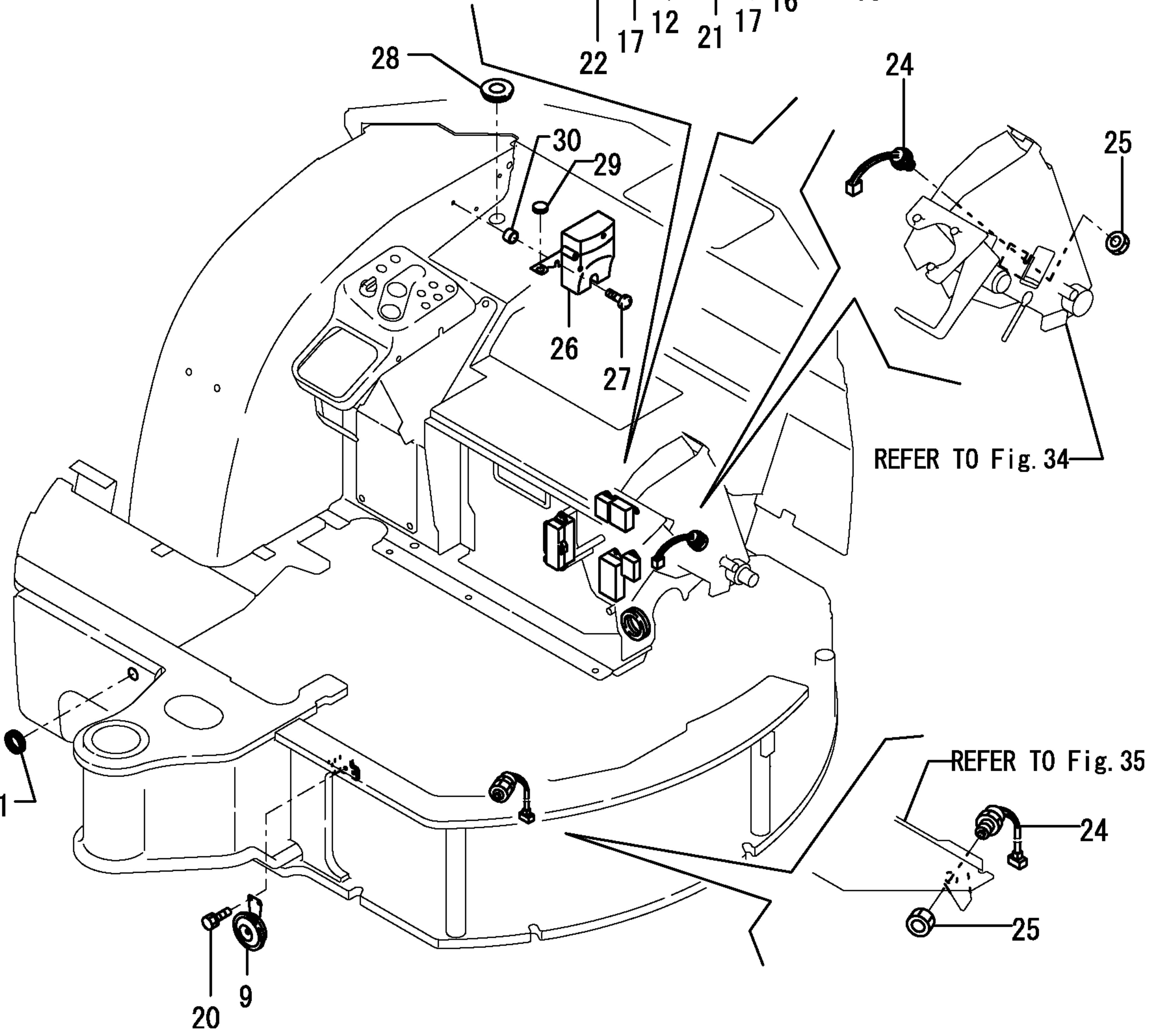
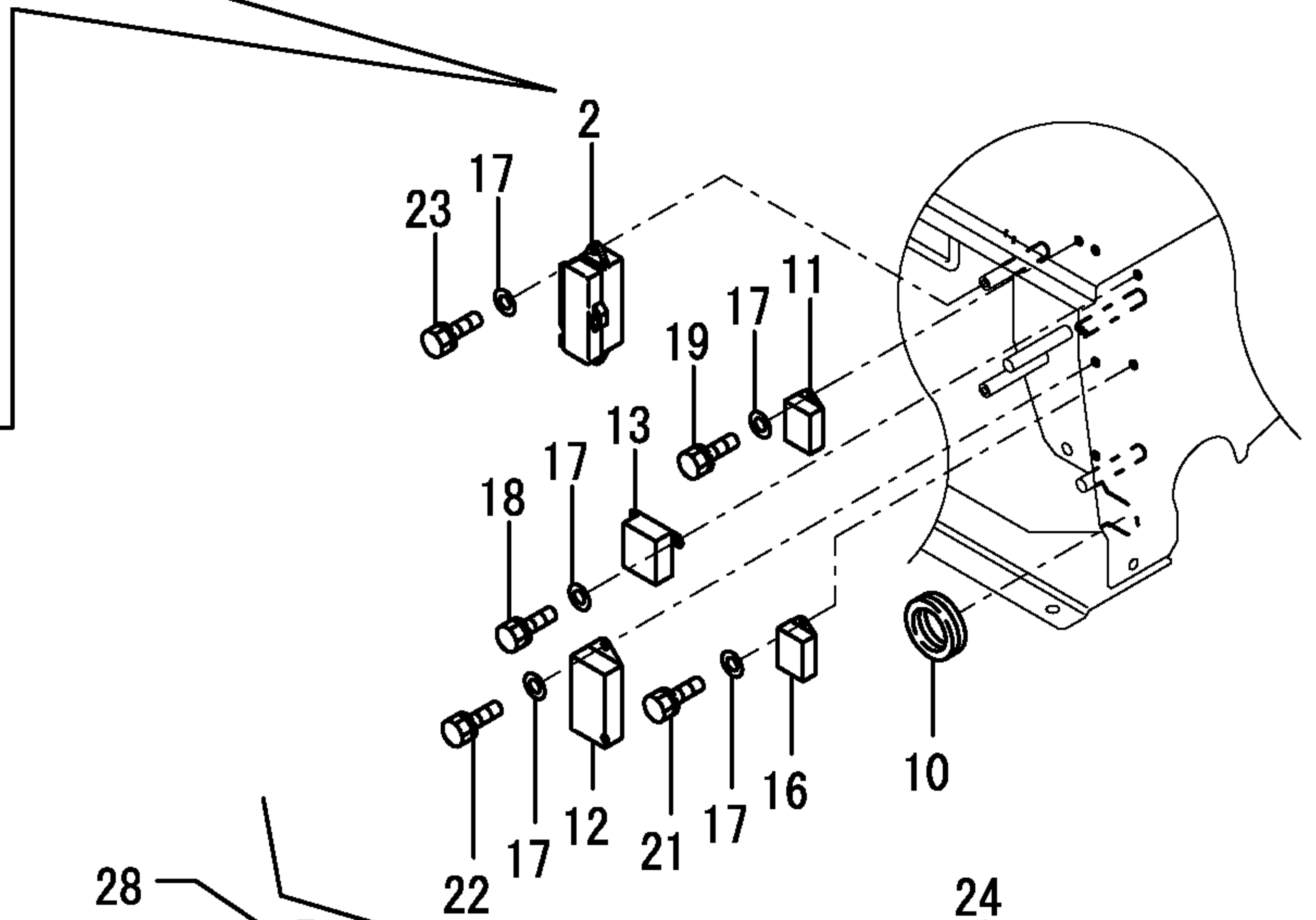
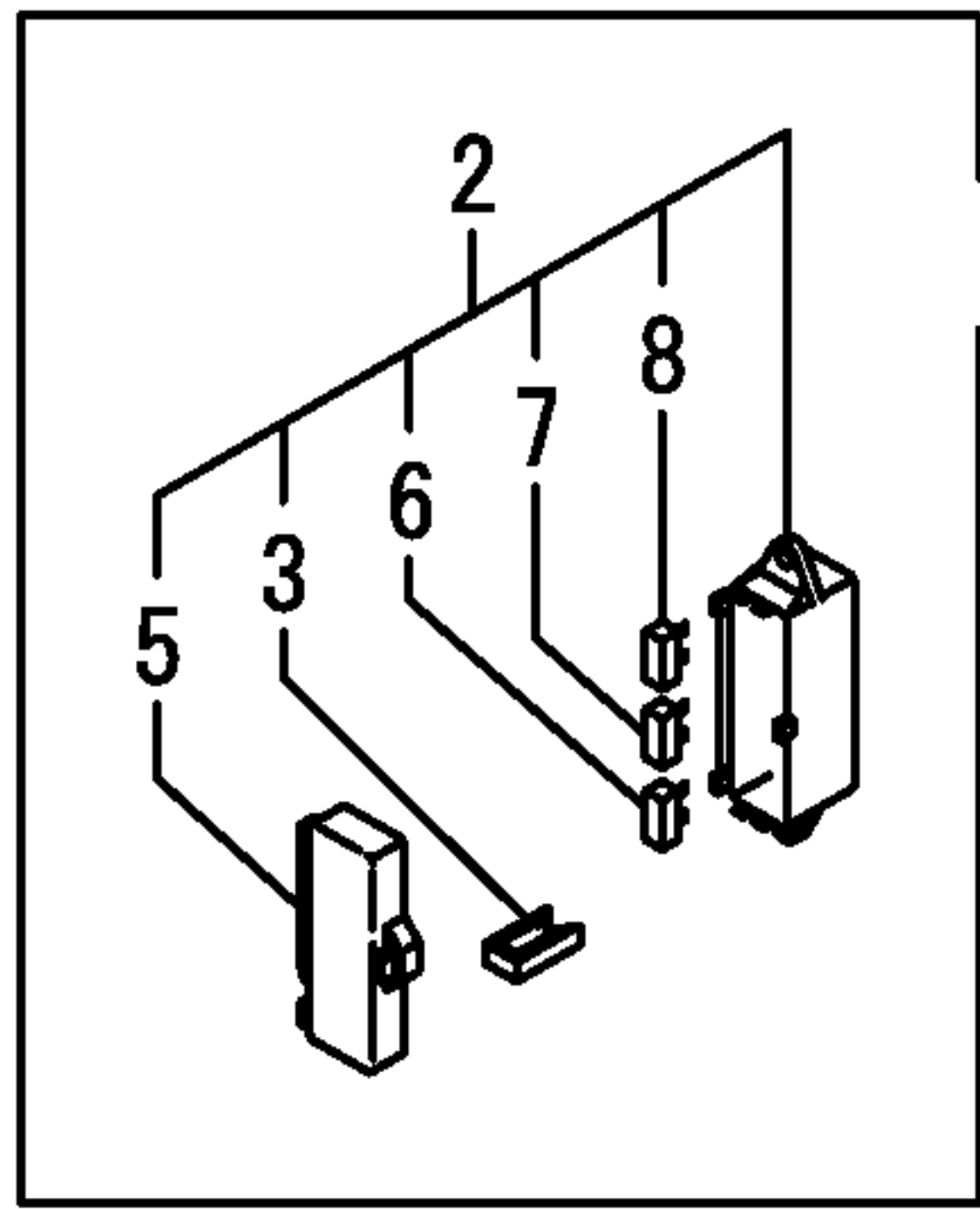

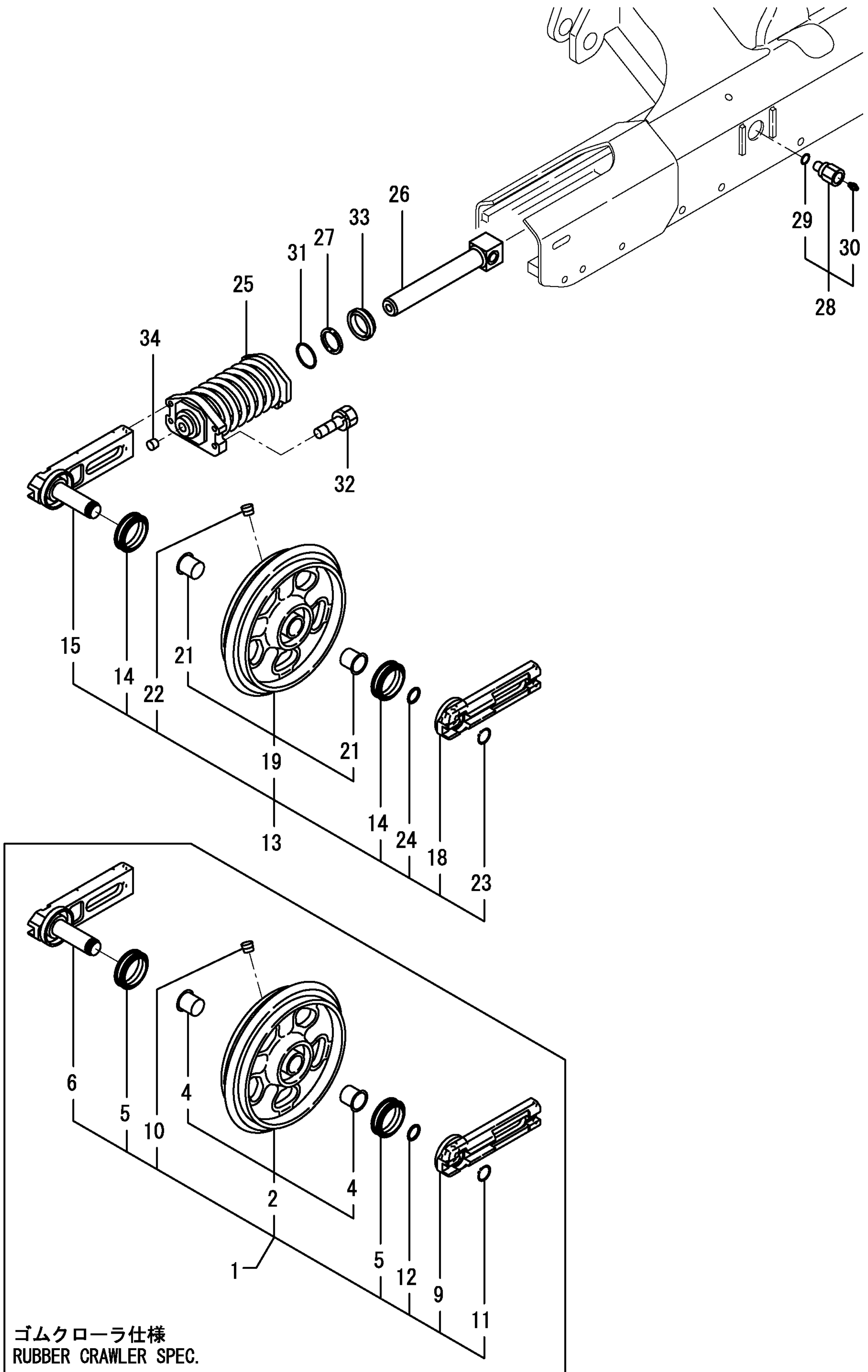

ゴムクローラ仕様  
RUBBER CRAWLER SPEC.

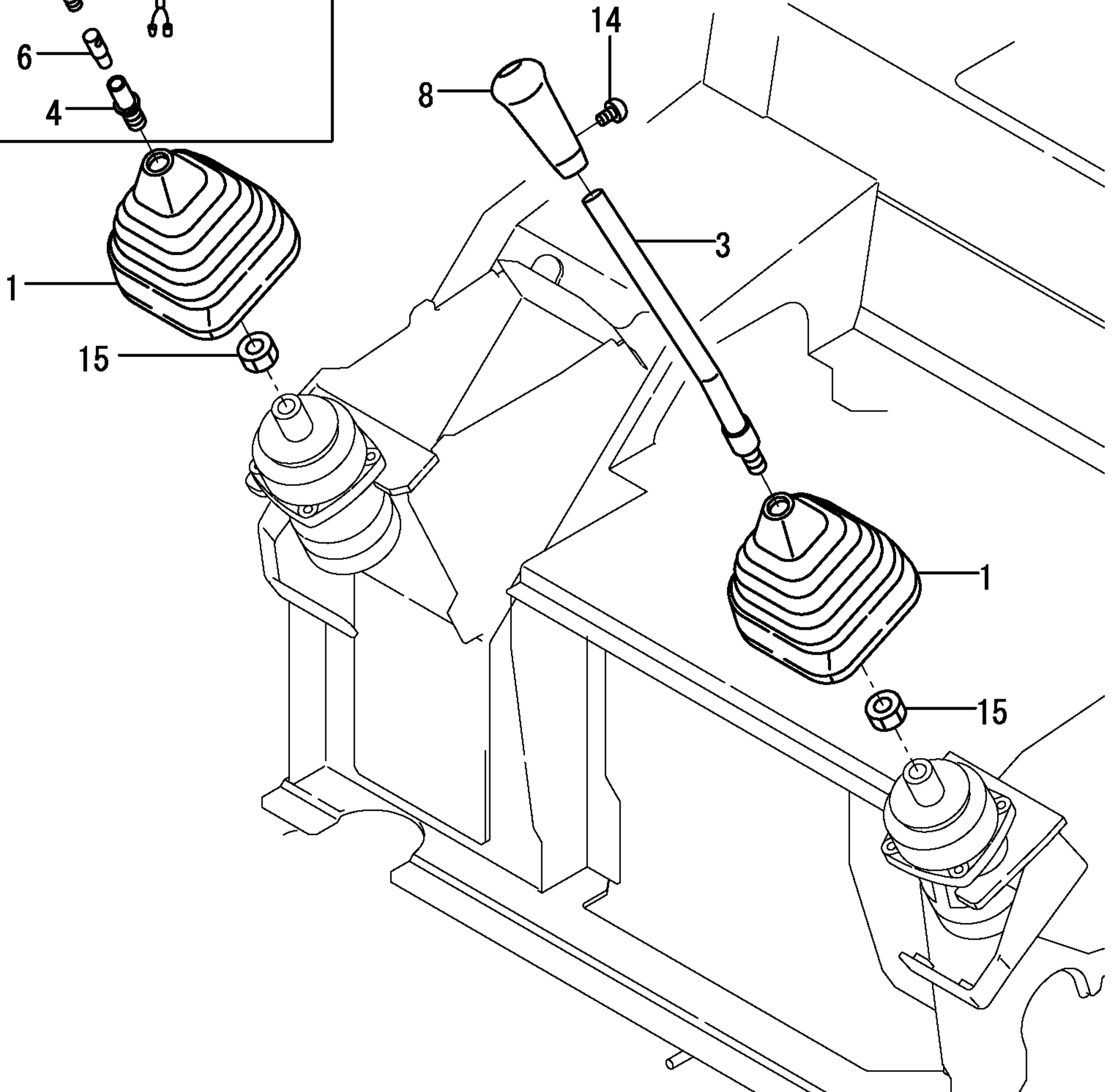
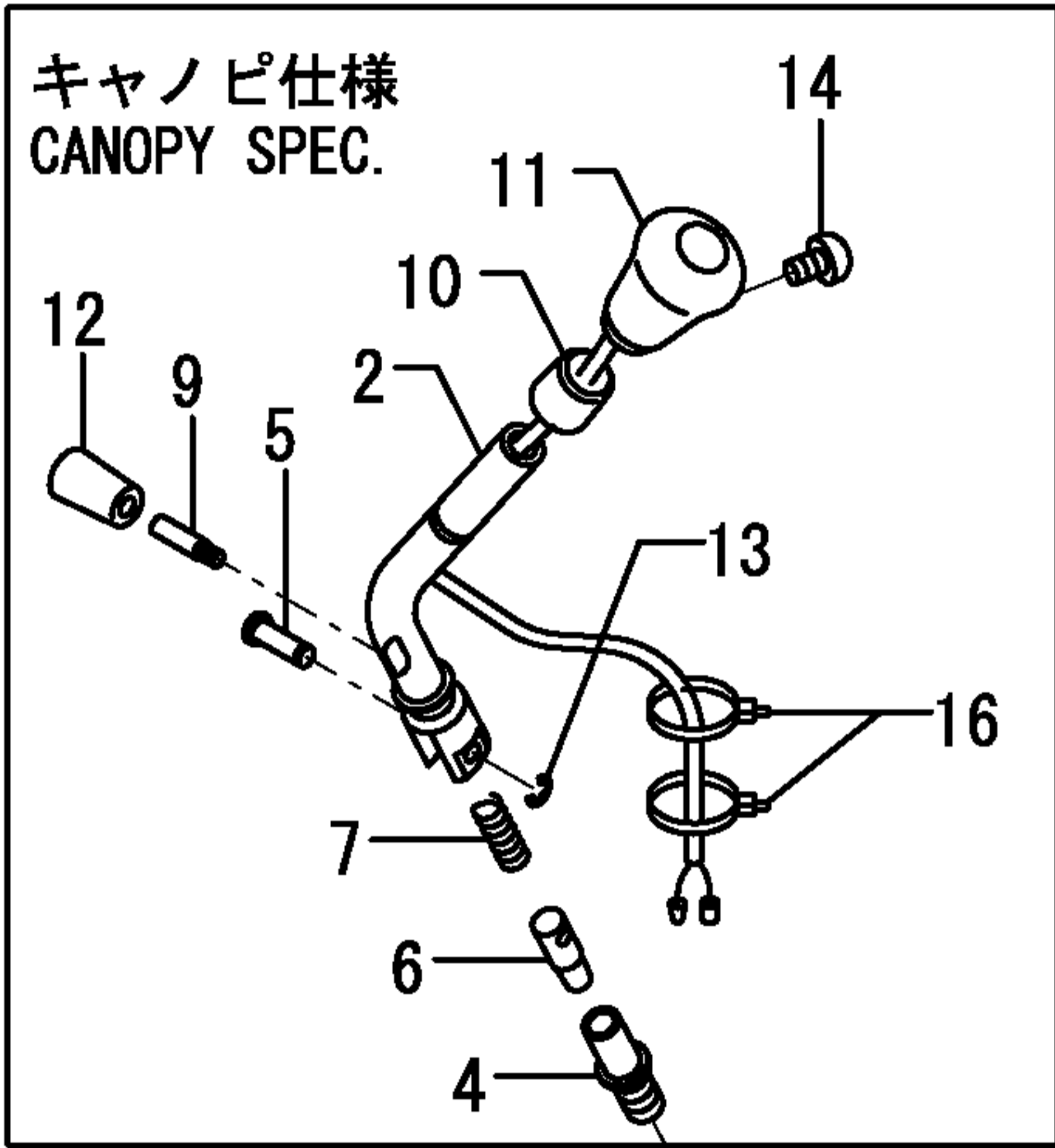
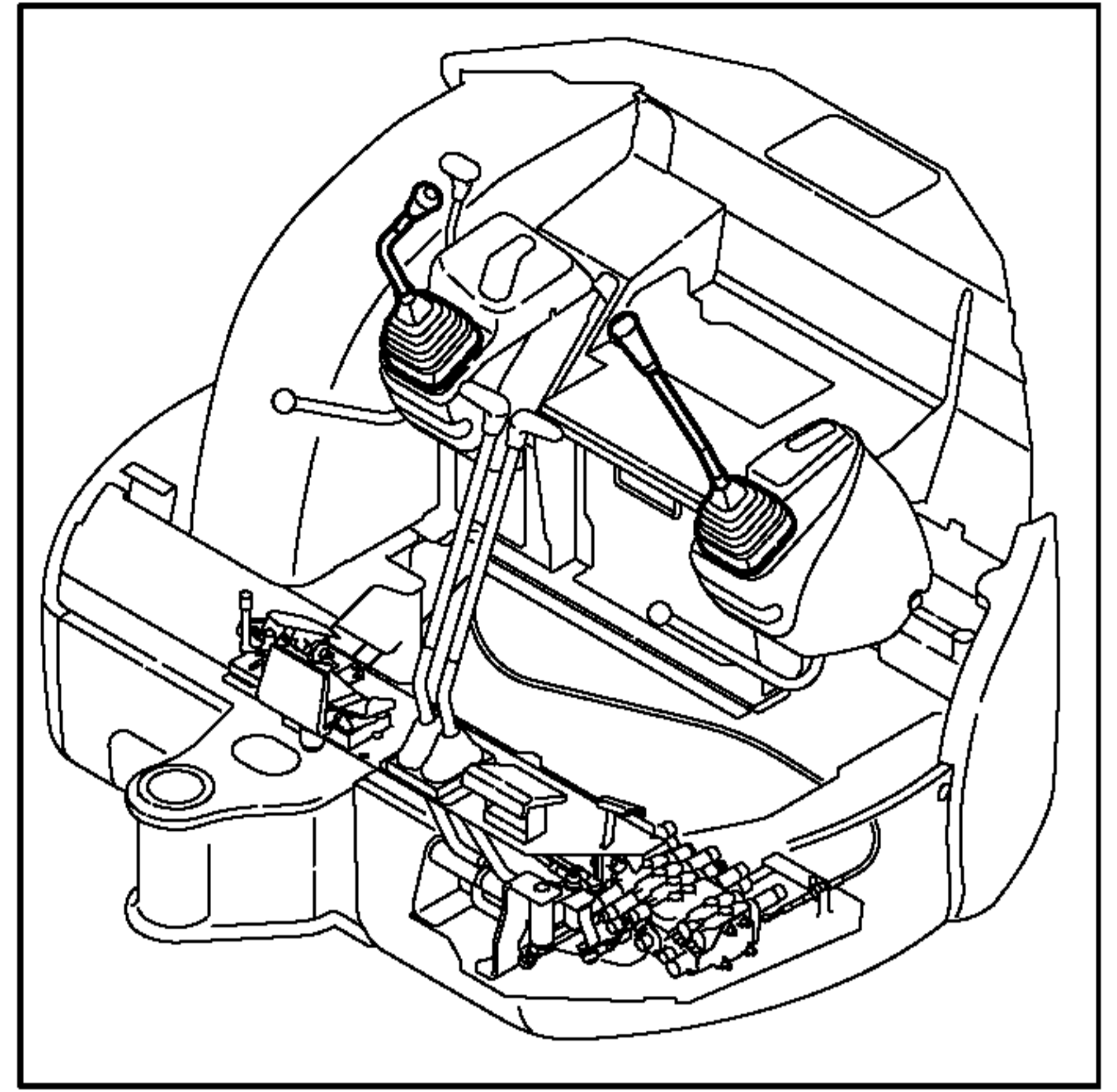
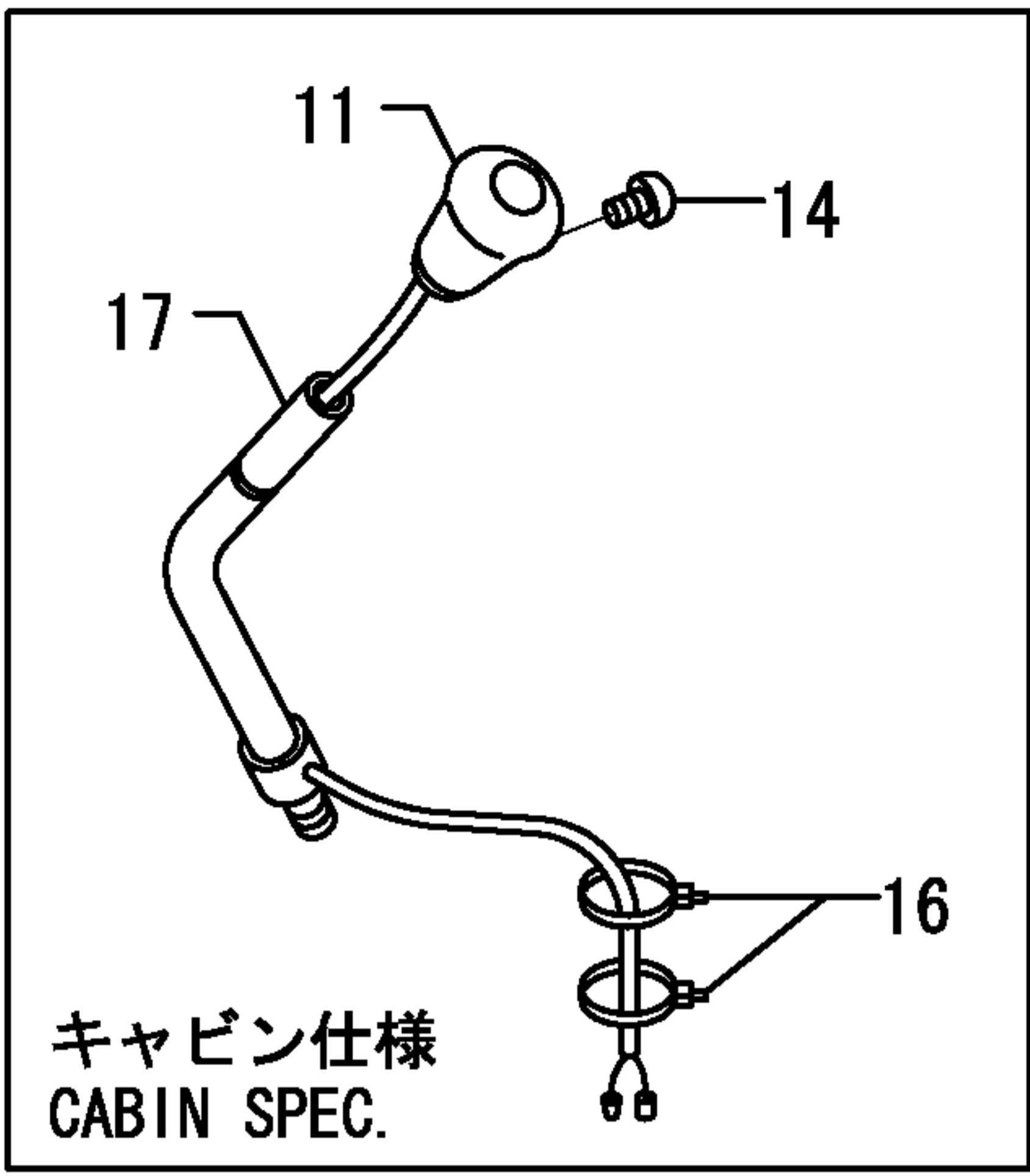

(172457-08700)

(172457-08701)

P.T.O.キットは、  
項目NO. 120を参照下さい。

P.T.O. KIT  
is shown in Fig. 120.

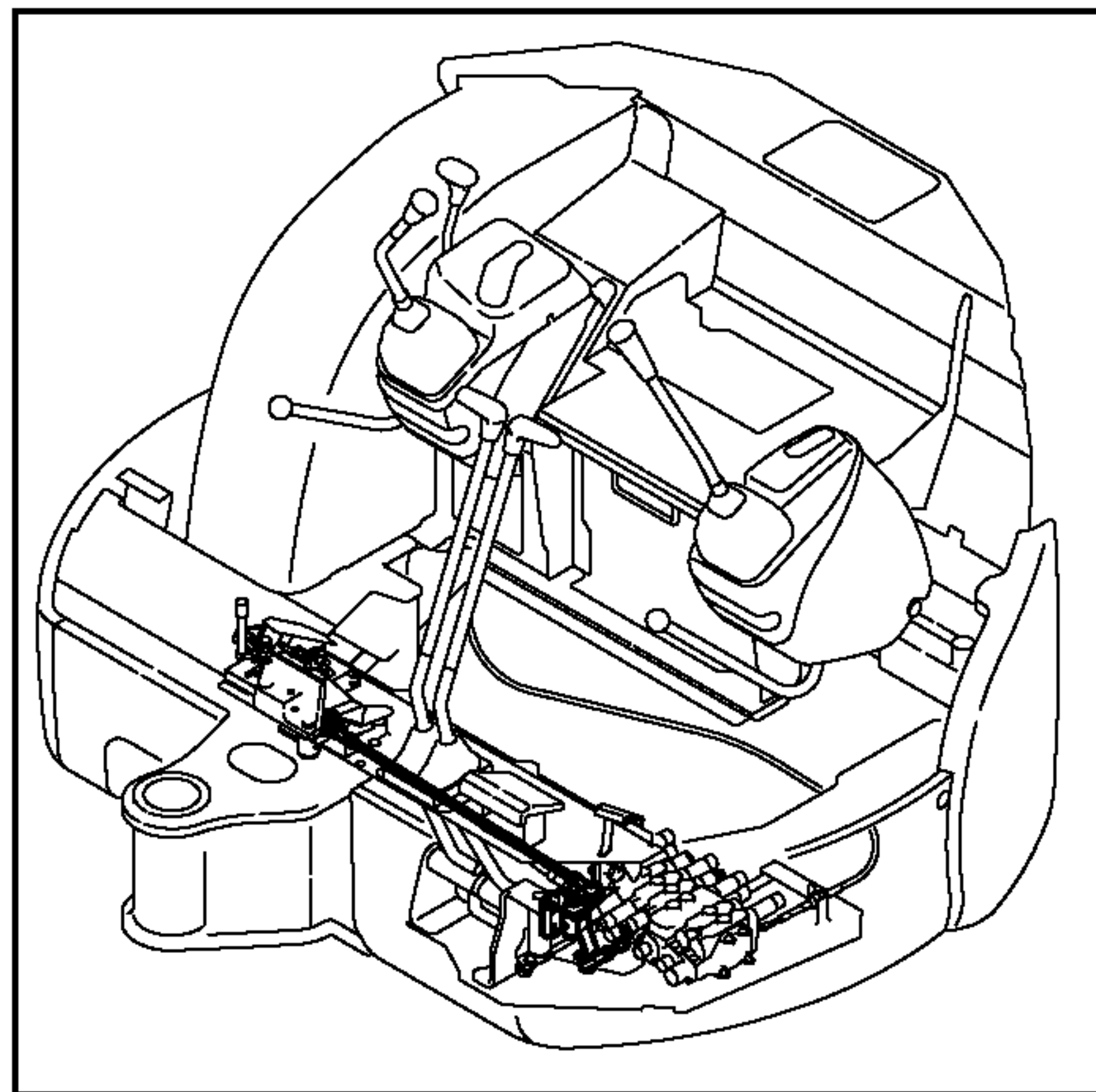

REFER TO Fig. 40

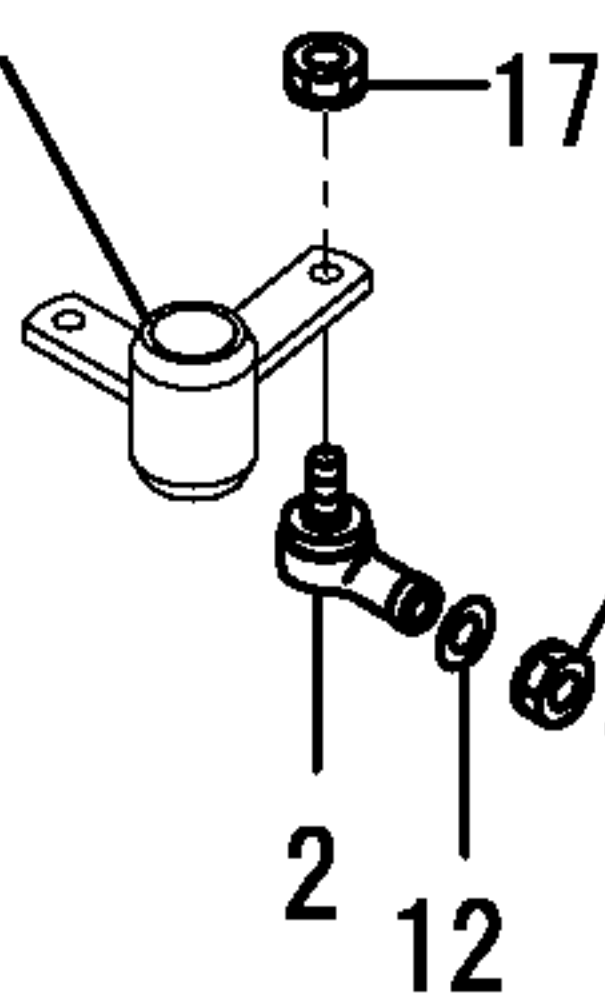

REFER TO Fig. 35

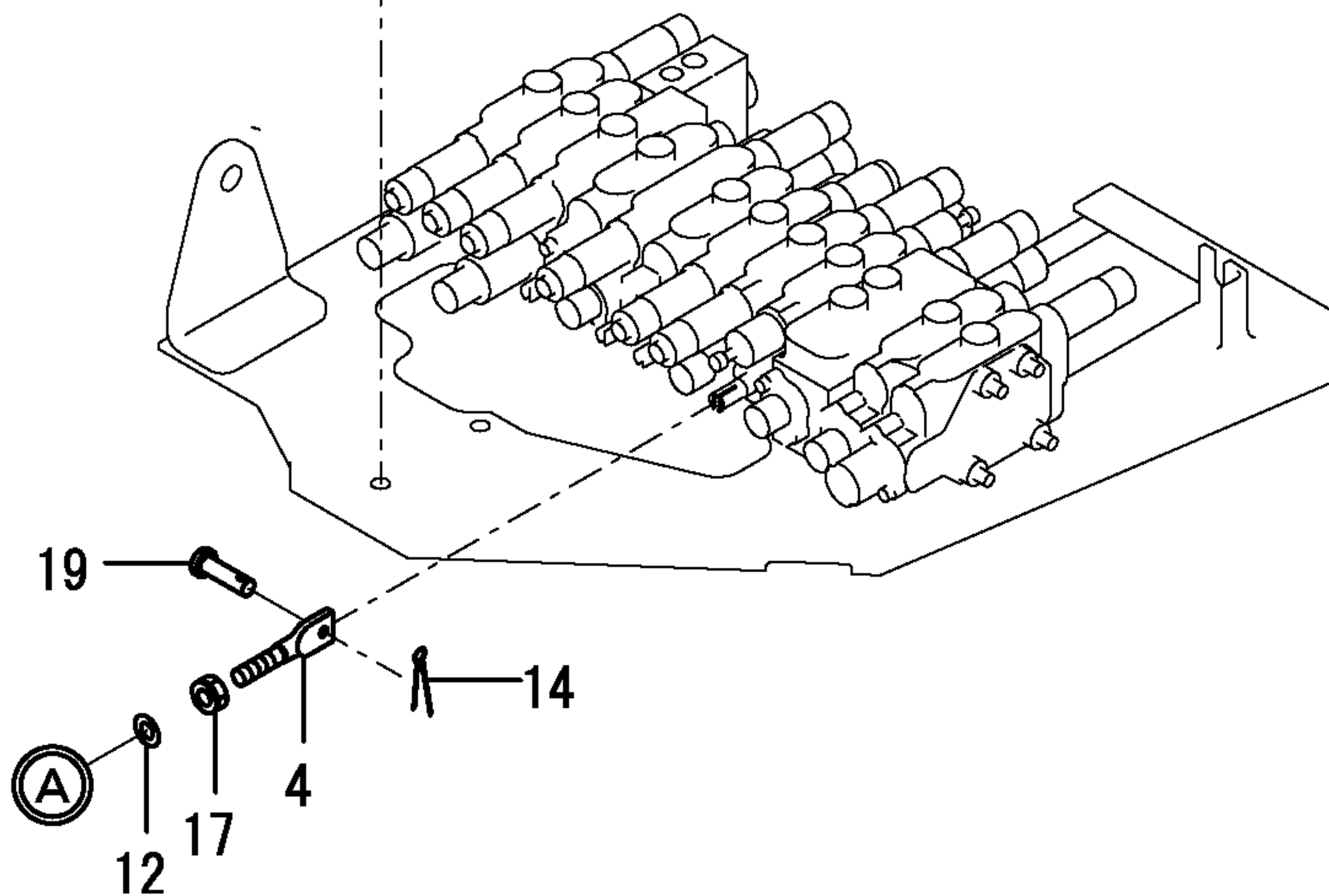
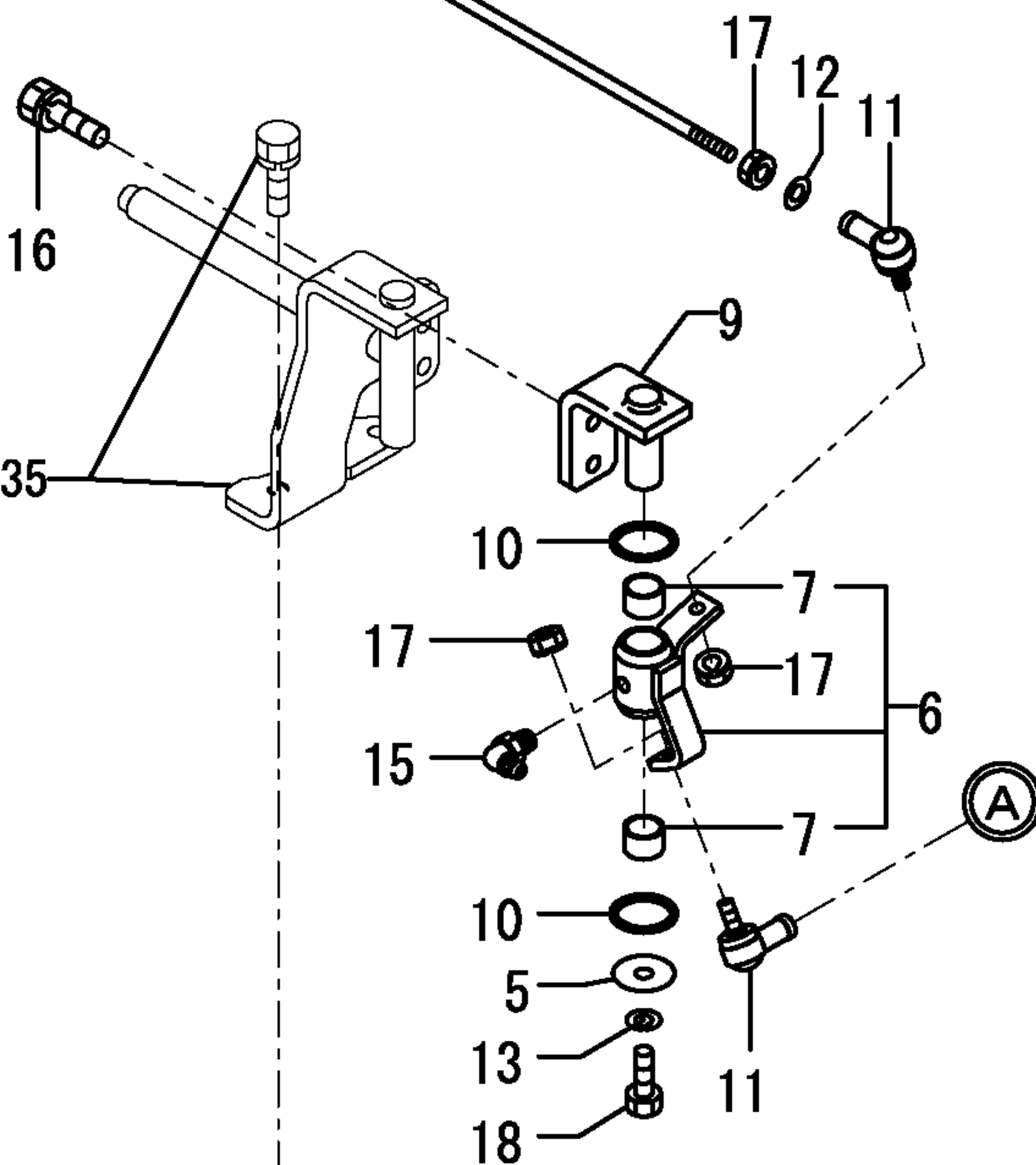

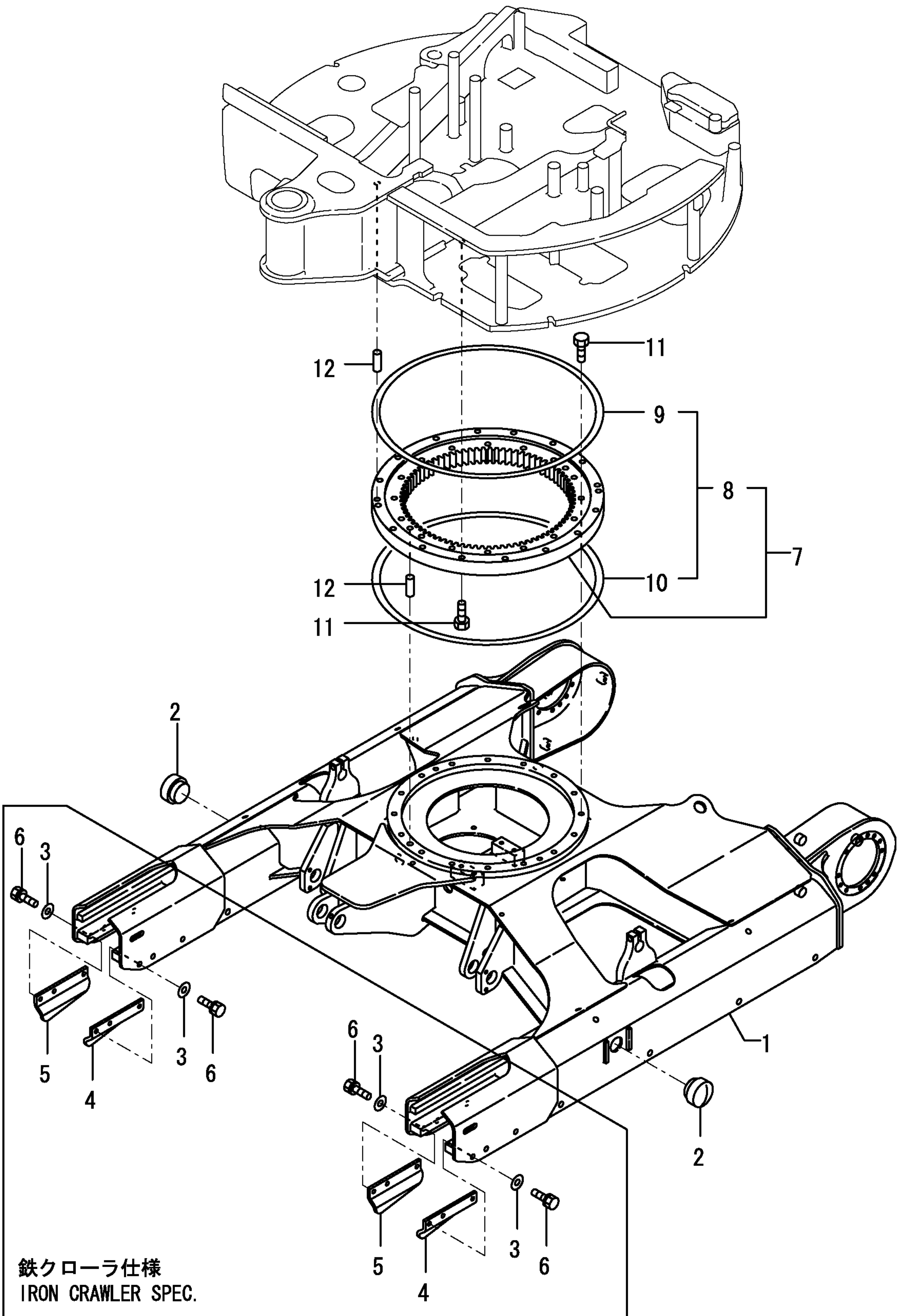

鉄クローラ仕様  
IRON CRAWLER SPEC.

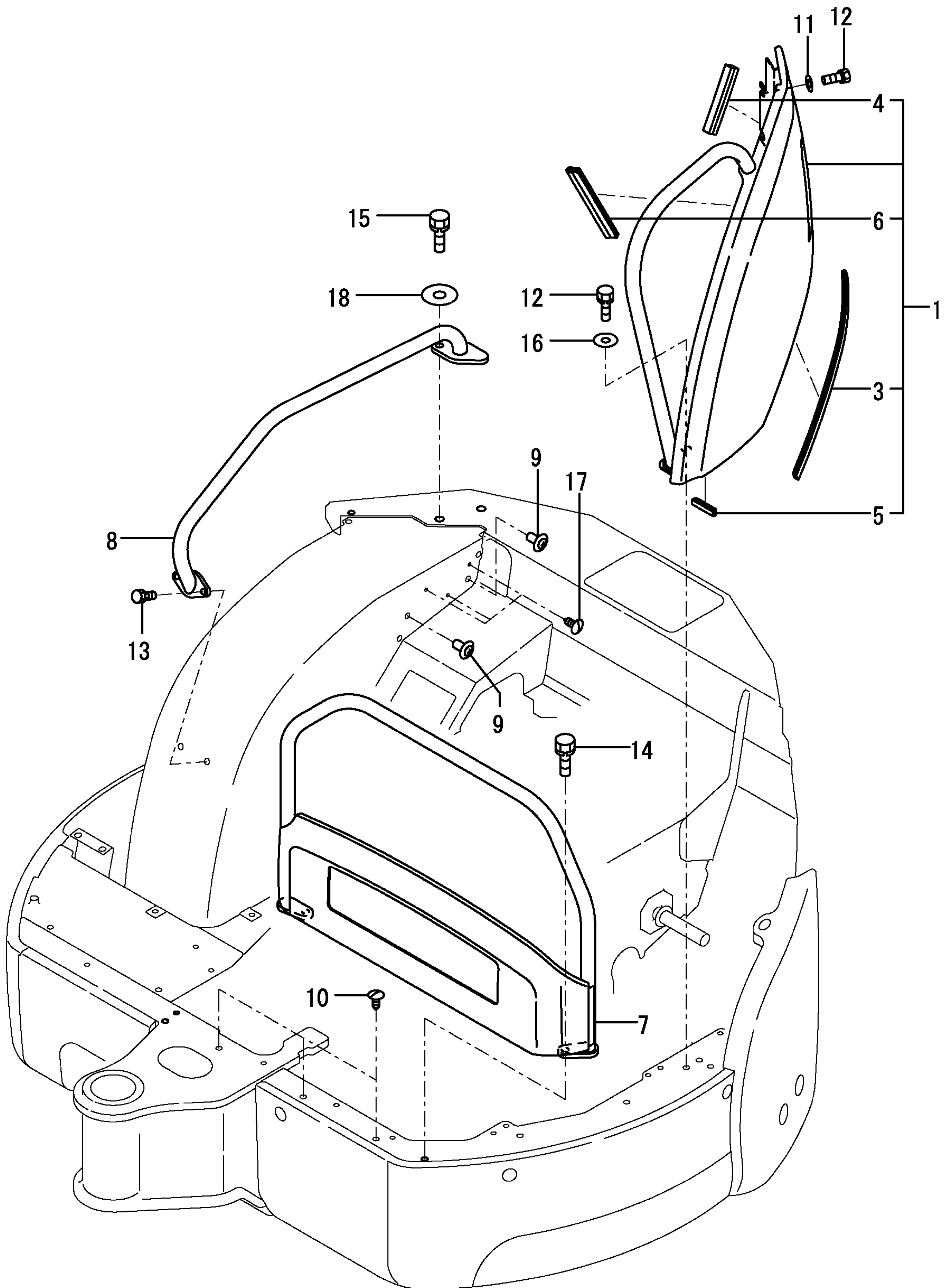

CLICK HERE TO **DOWNLOAD** THE COMPLETE MANUAL

- Thank you very much for reading the preview of the manual.
- You can download the complete manual from: [www.heydownloads.com](http://www.heydownloads.com) by clicking the link below



- Please note: If there is no response to CLICKING the link, please download this PDF first and then click on it.

CLICK HERE TO **DOWNLOAD** THE COMPLETE MANUAL

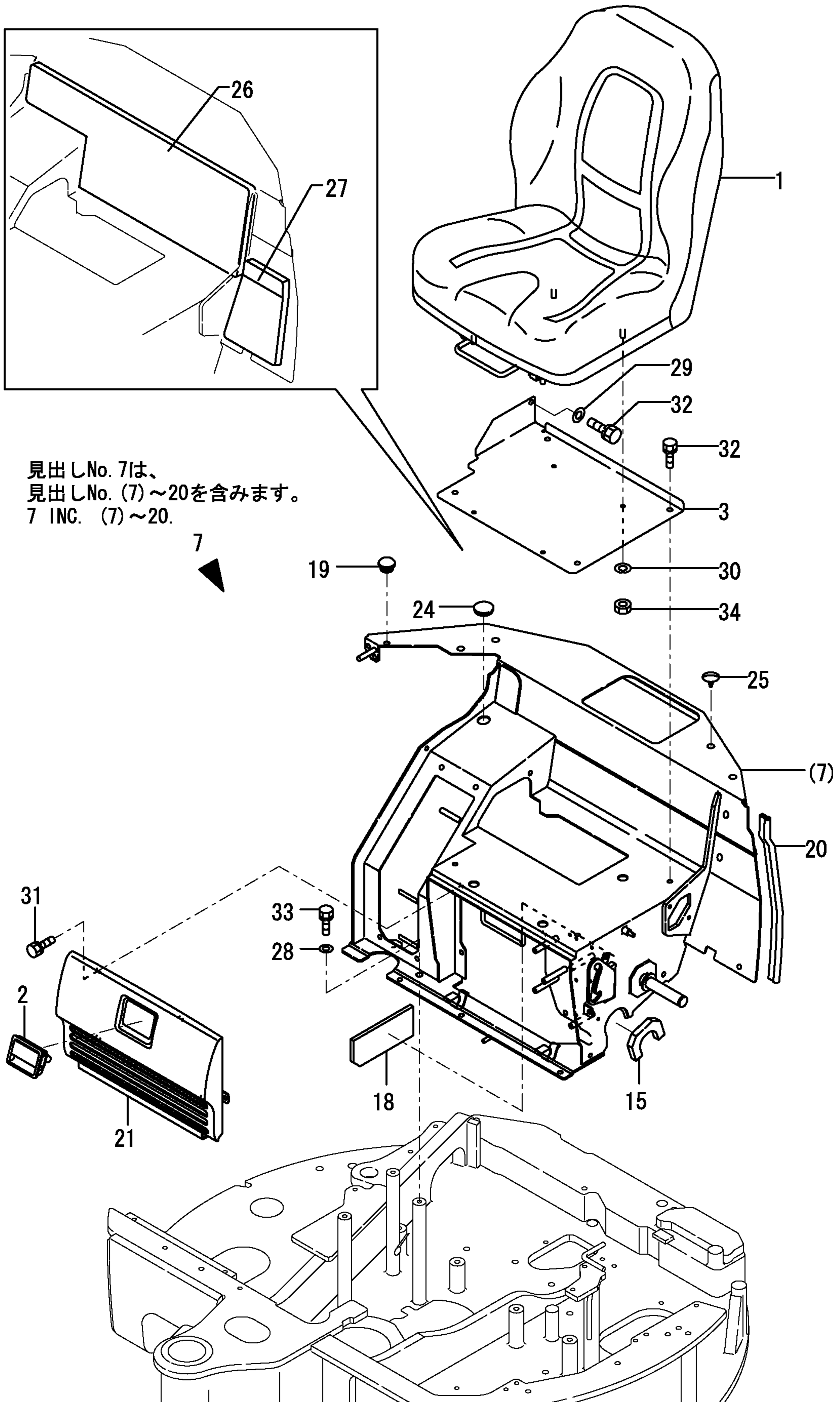

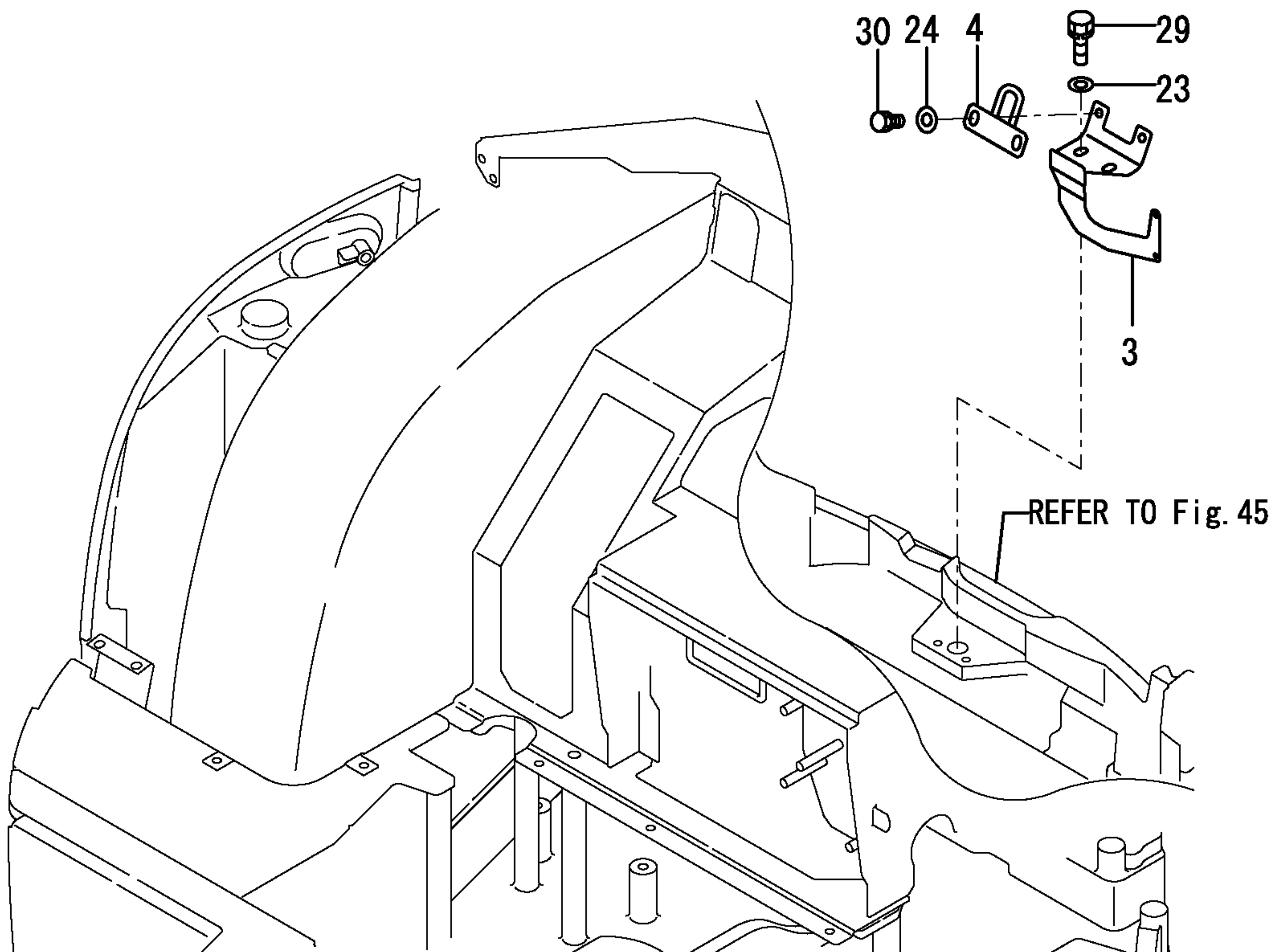
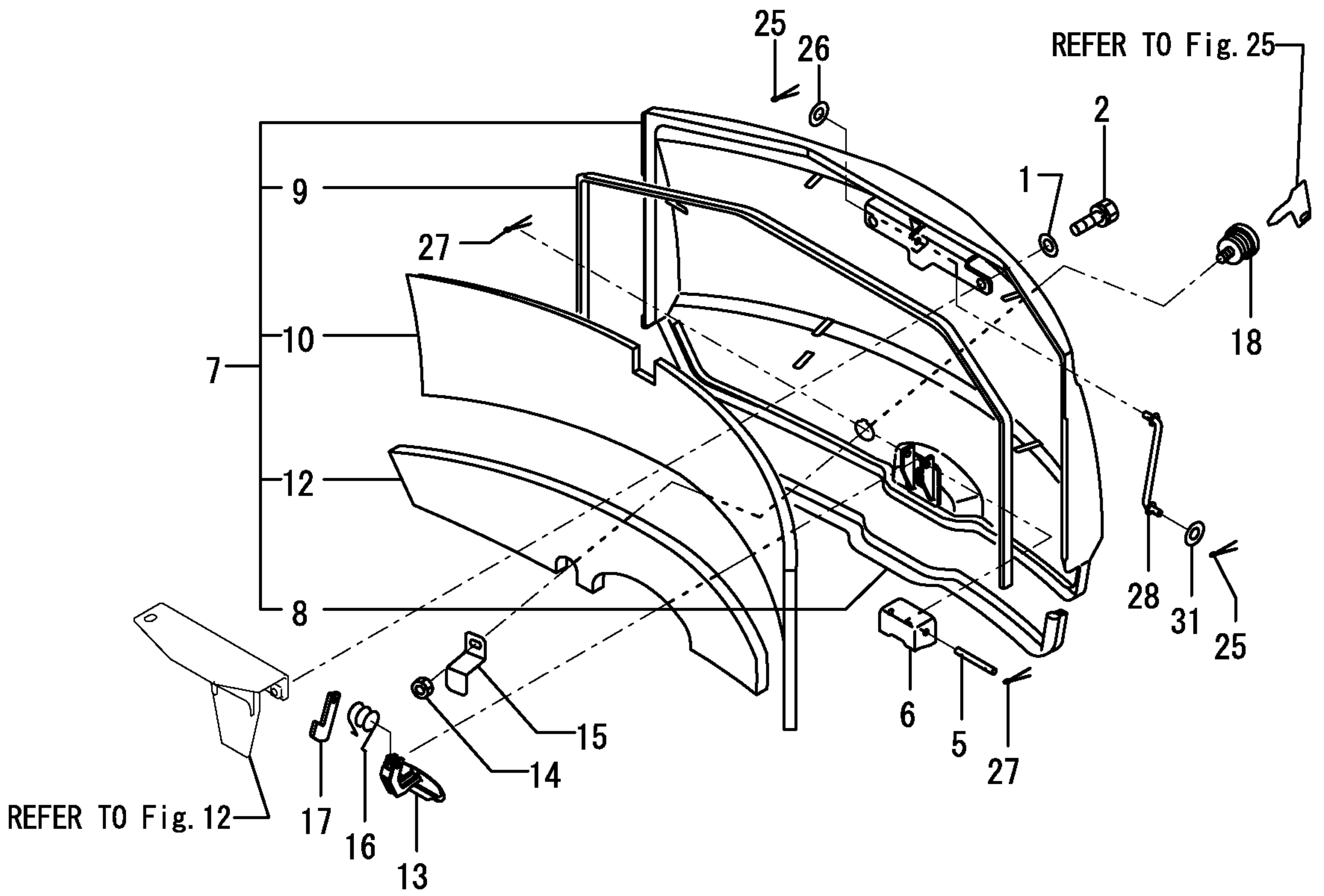

キャビンASSY

CABIN ASSY

172458-67800

172458-67801

172458-67802

項目NO. 63の見出しNO. 6, 6-1, 6-2は、

項目NO. 63の見出しNO. (6) ~34と

項目NO. 64の見出しNO. 1~44と

項目NO. 65の見出しNO. 1~18と

項目NO. 66の見出しNO. 1~21と

項目NO. 67の見出しNO. 1を含みます。

Fig. 63 Ref No. 6, 6-1, 6-2

INC Fig. 63 Ref No. (6) ~34.

Fig. 64 Ref No. 1~44.

Fig. 65 Ref No. 1~18.

Fig. 66 Ref No. 1~21.

Fig. 67 Ref No. 1.

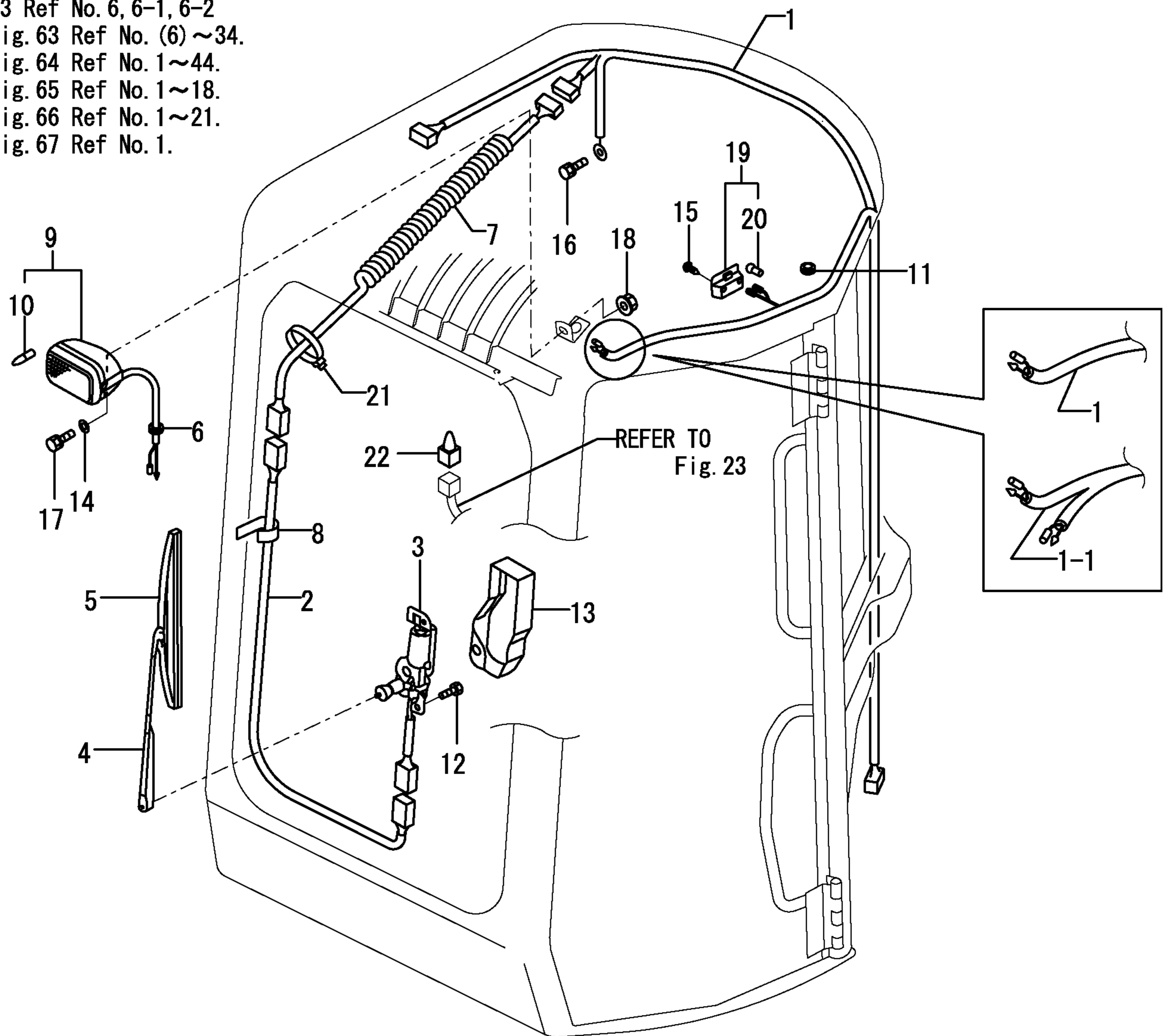

55,4,,24315-000110,, "O-RING 1B P-11.0",1,1,,,,,,,,,,,,,  
56,4,,24321-000850,, "O-RING 1A G-85.0",1,1,,,,,,,,,,,,,  
57,4,,24315-000080,, "O-RING 1B P-8.0",1,1,,,,,,,,,,,,,  
58,4,,24315-000180,, "O-RING 1B P-18.0",2,2,,,,,,,,,,,,,  
59,3,,172457-73620,, "BLOCK KIT, CYLINDER",1,1,,,,,,,,,,,,,  
60,3,,172457-73630,, "RETAINER KIT",1,1,,,,,,,,,,,,,  
61,3,,172457-73640,, "SWASH PLATE S/A",1,1,,,,,,,,,,,,,  
63,1,,26013-120352,, "BOLT M12X 35",2,2,,,,,,,,,,,,,

見出しNo. 1は、  
見出しNo. 2~24を含みます。  
1 INC. 2~24.

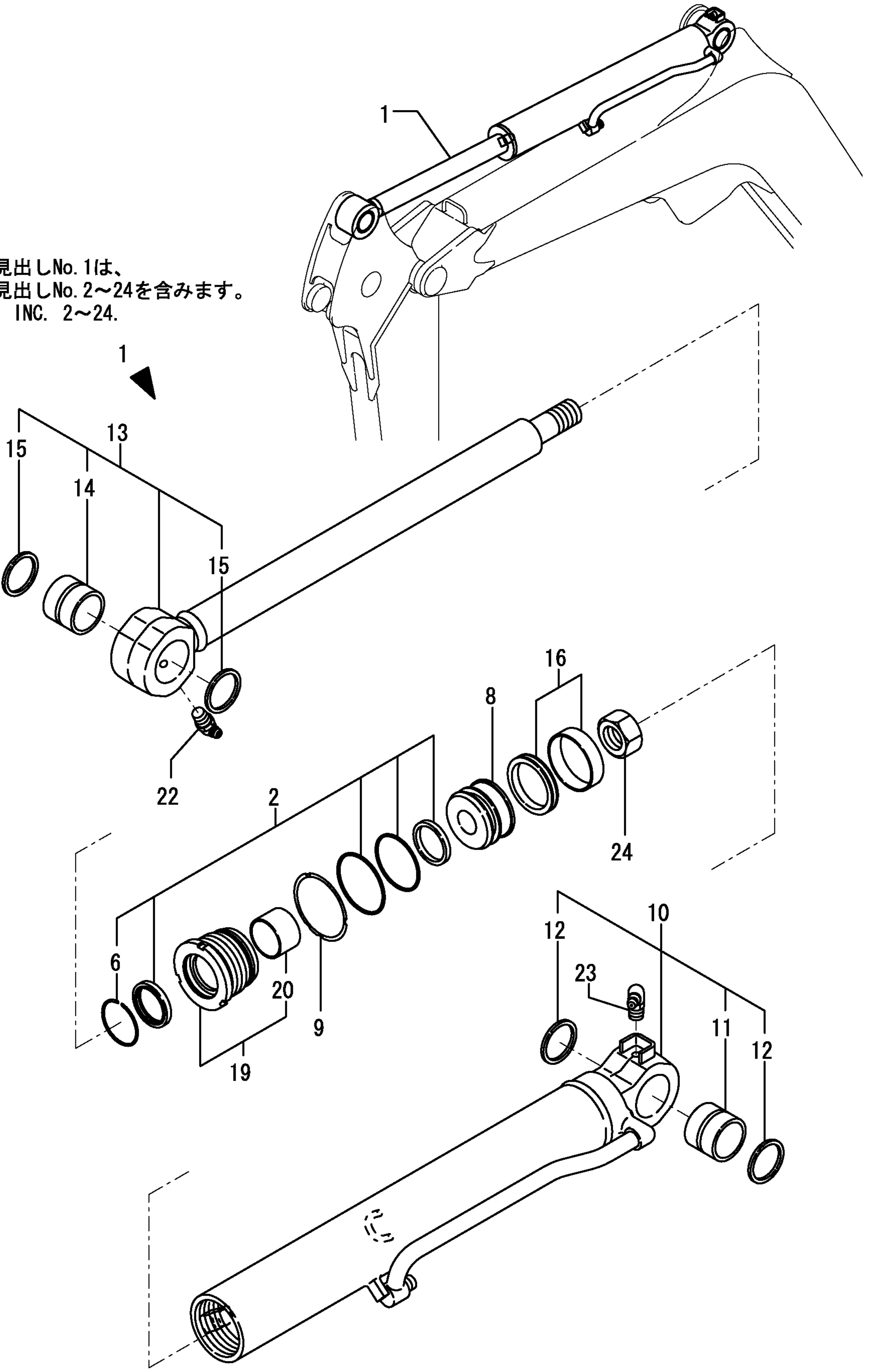



項目NO. 84の見出しNO. 1は、  
 項目NO. 84の見出しNO. 2~29と  
 項目NO. 85の見出しNO. 1~28と  
 項目NO. 86の見出しNO. 1~25を含みます。  
 項目NO. 87の見出しNO. 1~30と  
 項目NO. 88の見出しNO. 1~34と  
 項目NO. 89の見出しNO. 1~25を含みます。

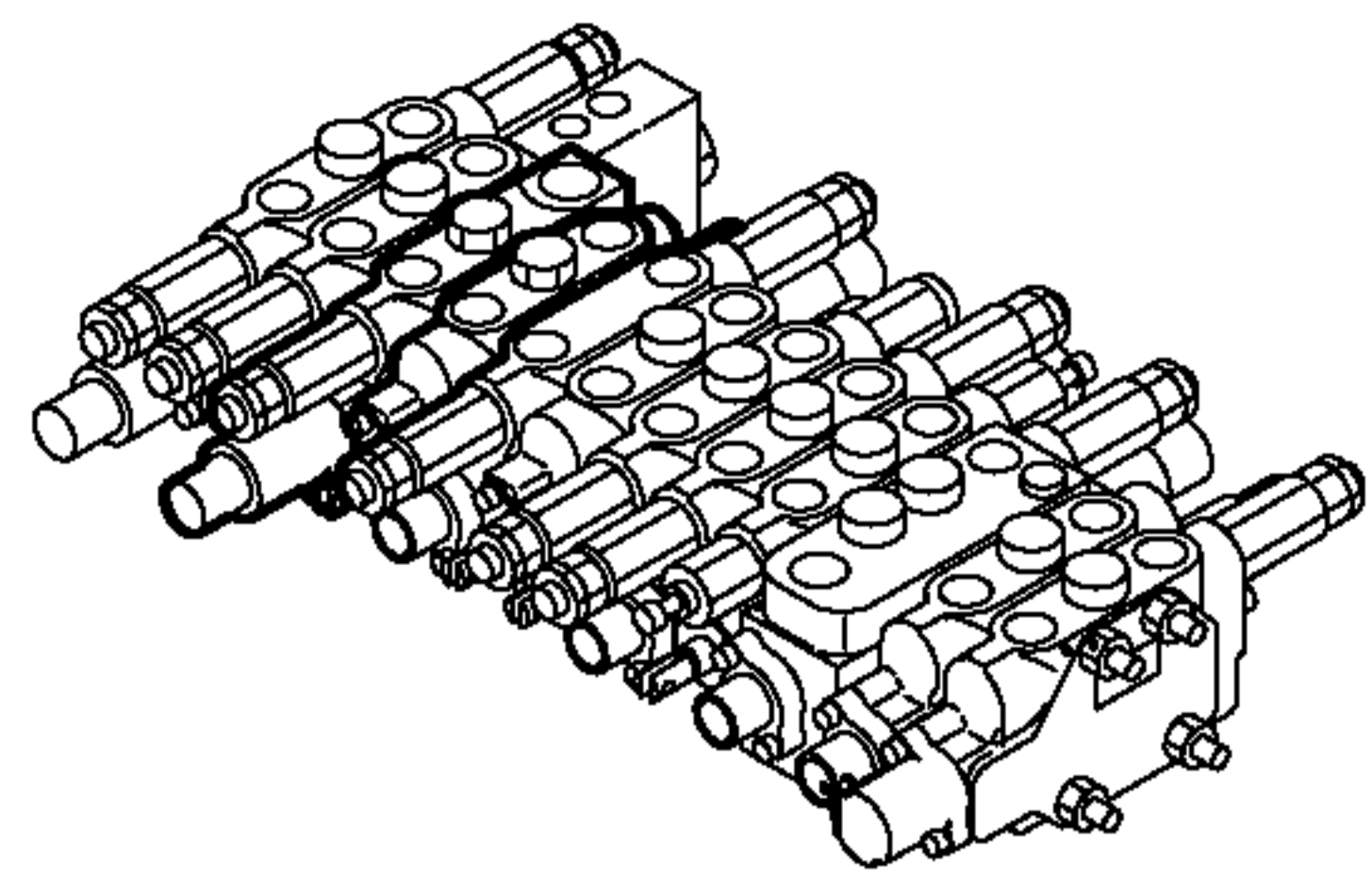

Fig. 84 Ref. No. 1

INC. Fig. 84 Ref. No. 2~29.

INC. Fig. 85 Ref. No. 1~28.

INC. Fig. 86 Ref. No. 1~25.

INC. Fig. 87 Ref. No. 1~30.

INC. Fig. 88 Ref. No. 1~34.

INC. Fig. 89 Ref. No. 1~25.

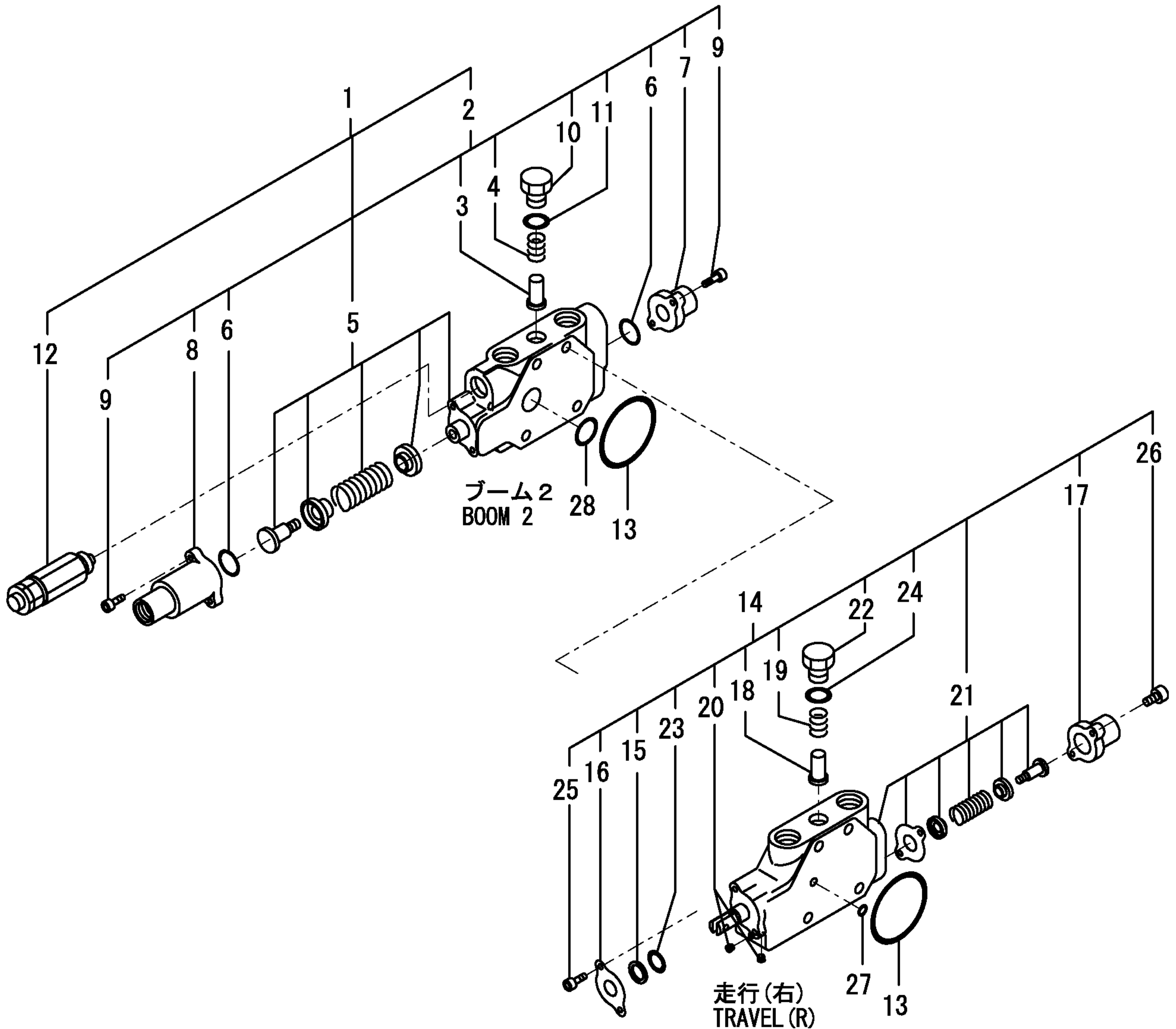

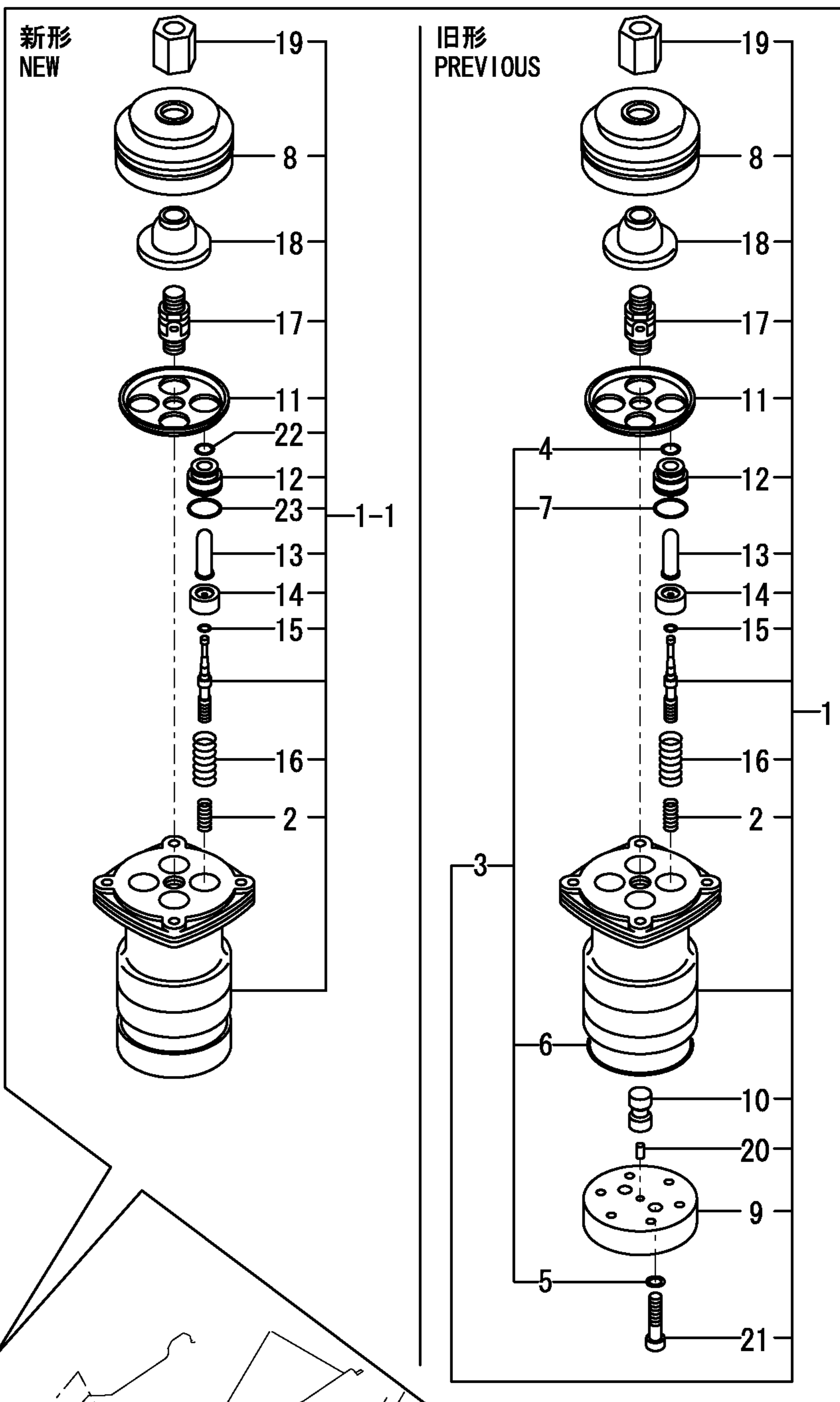

REFER TO Fig. 33

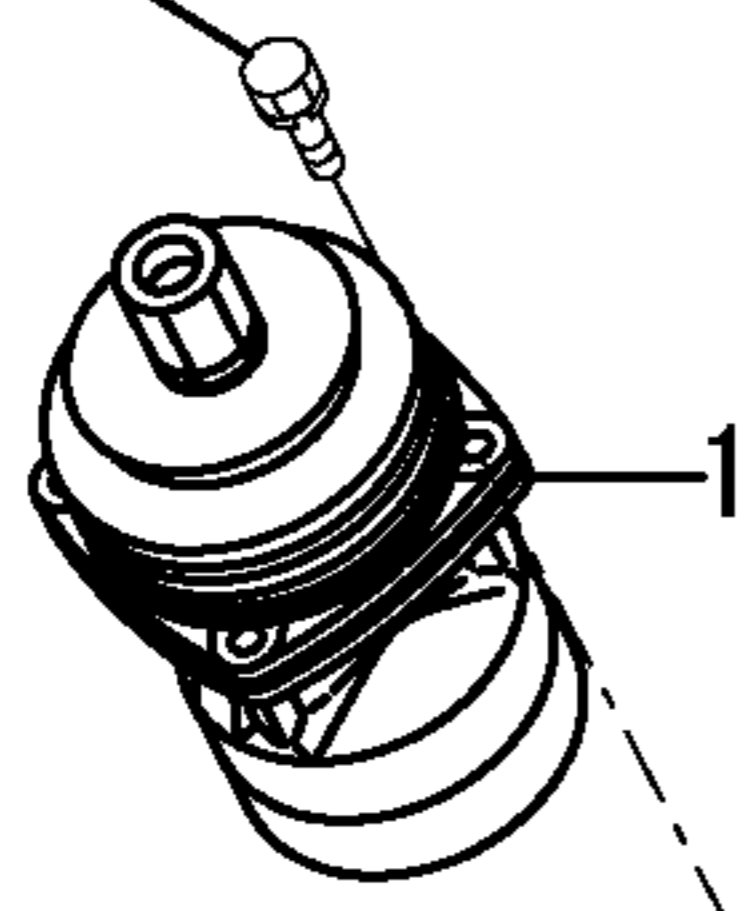

REFER TO Fig. 33

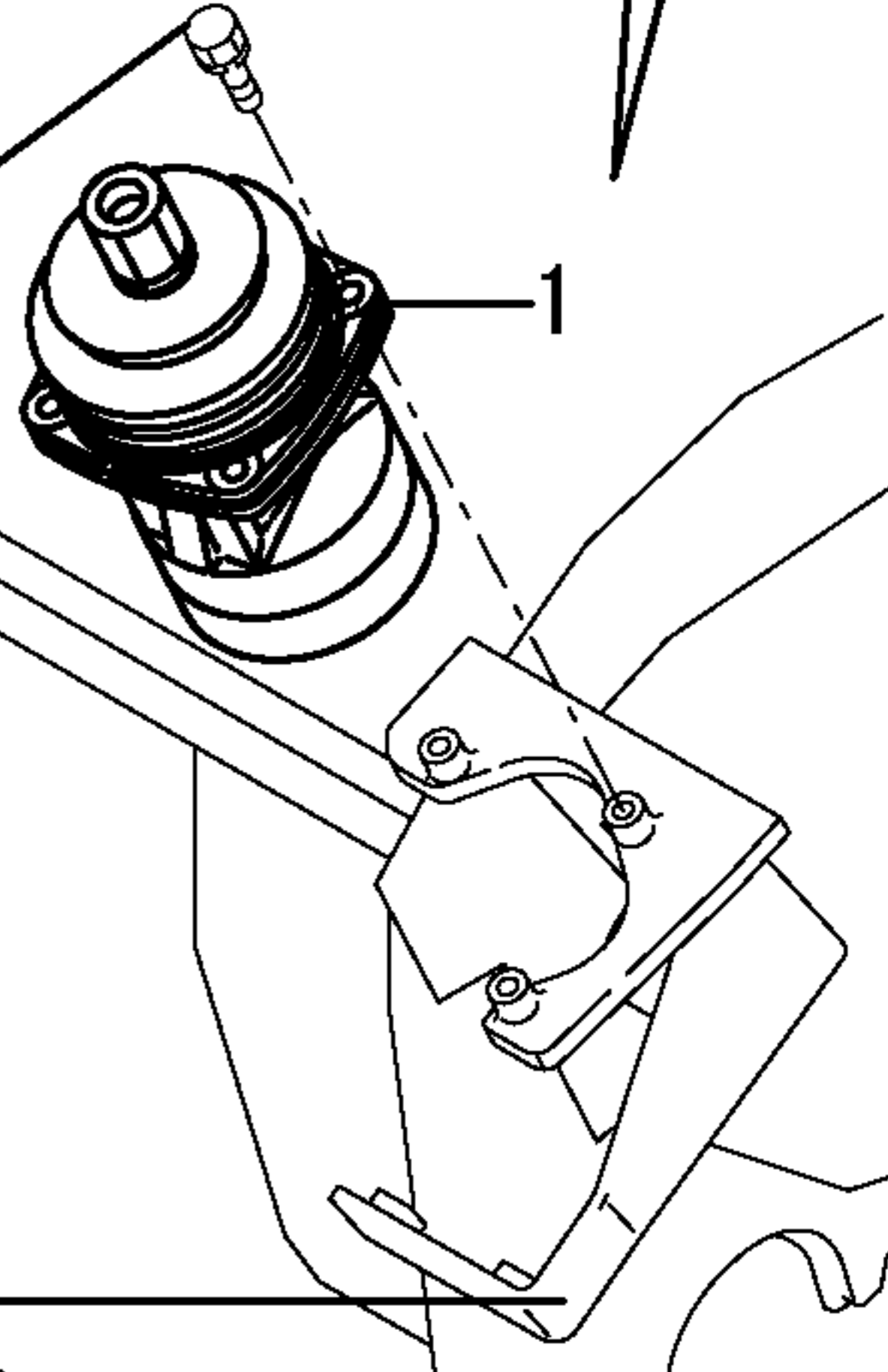

REFER TO Fig. 34

REFER TO Fig. 34

見出しNO. 1は  
見出しNO. (1)~33を含みます。  
見出しNO. 1-1は  
見出しNO. (1)~34を含みます。  
1 INC. (1)~33.  
1-1 INC. (1)~34.

1, 1-1

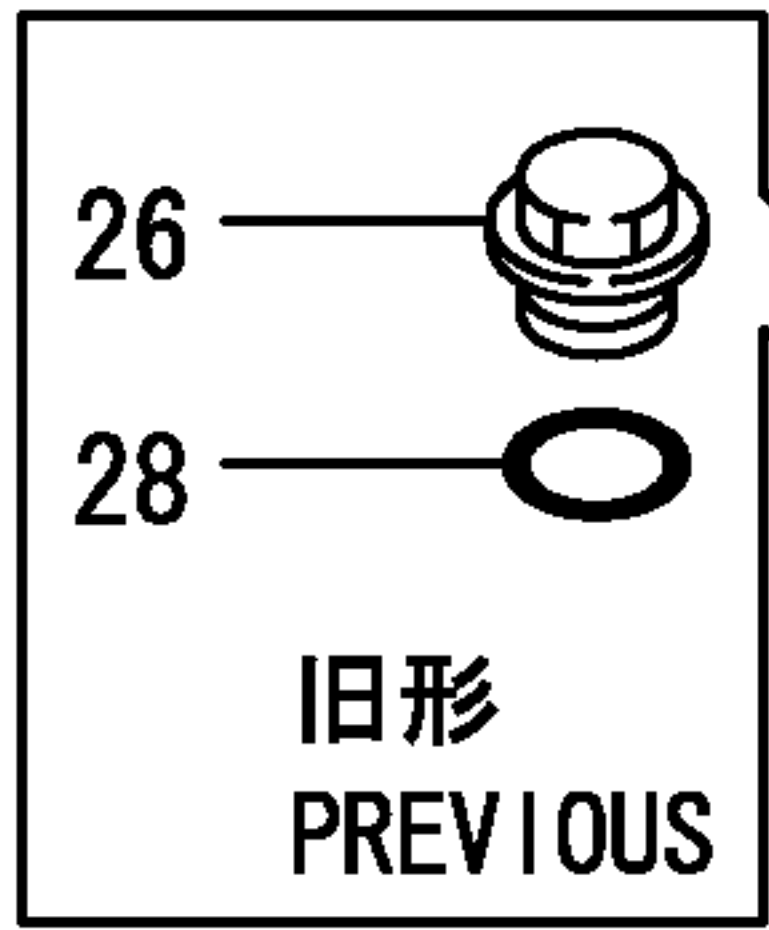

26-1

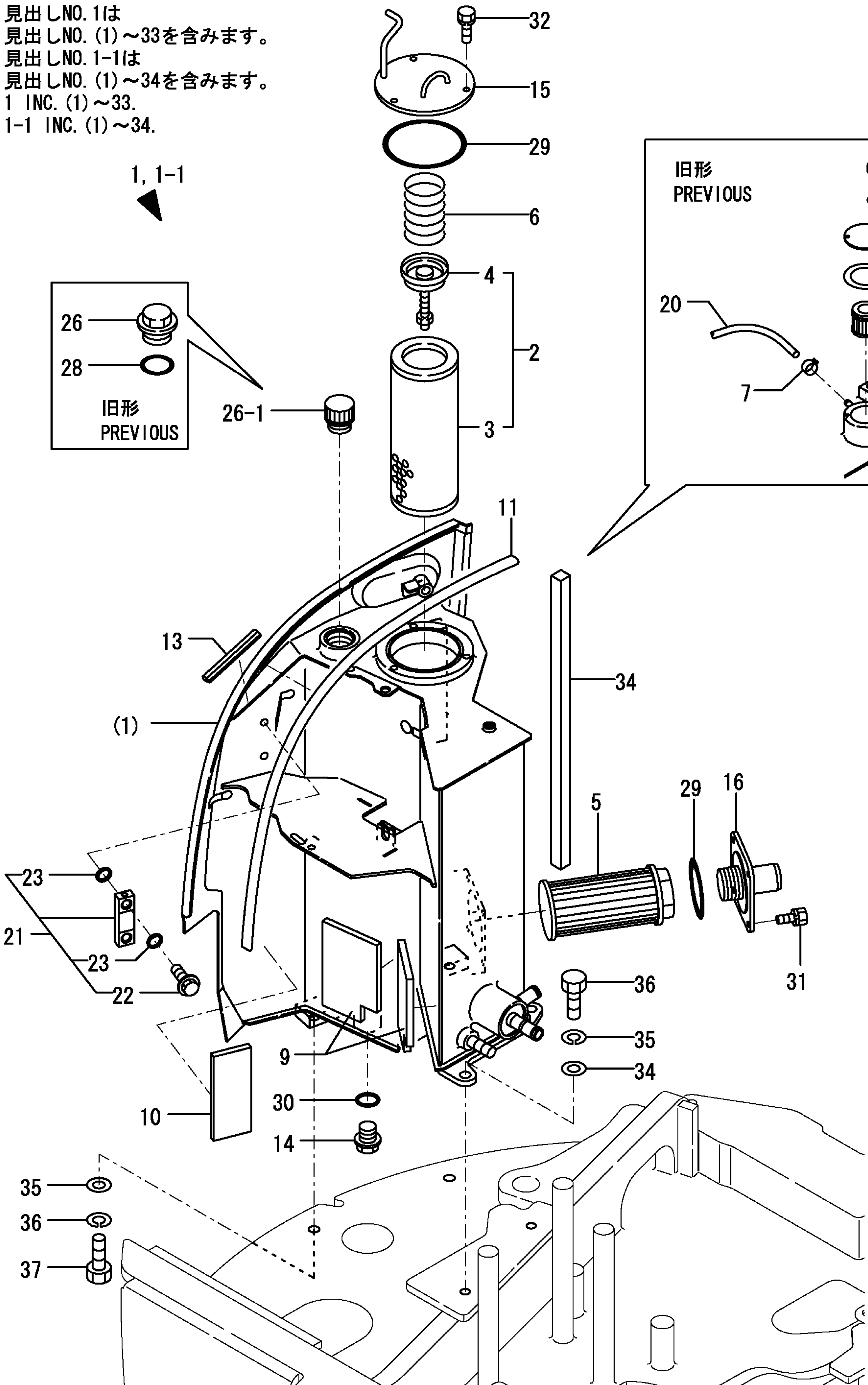
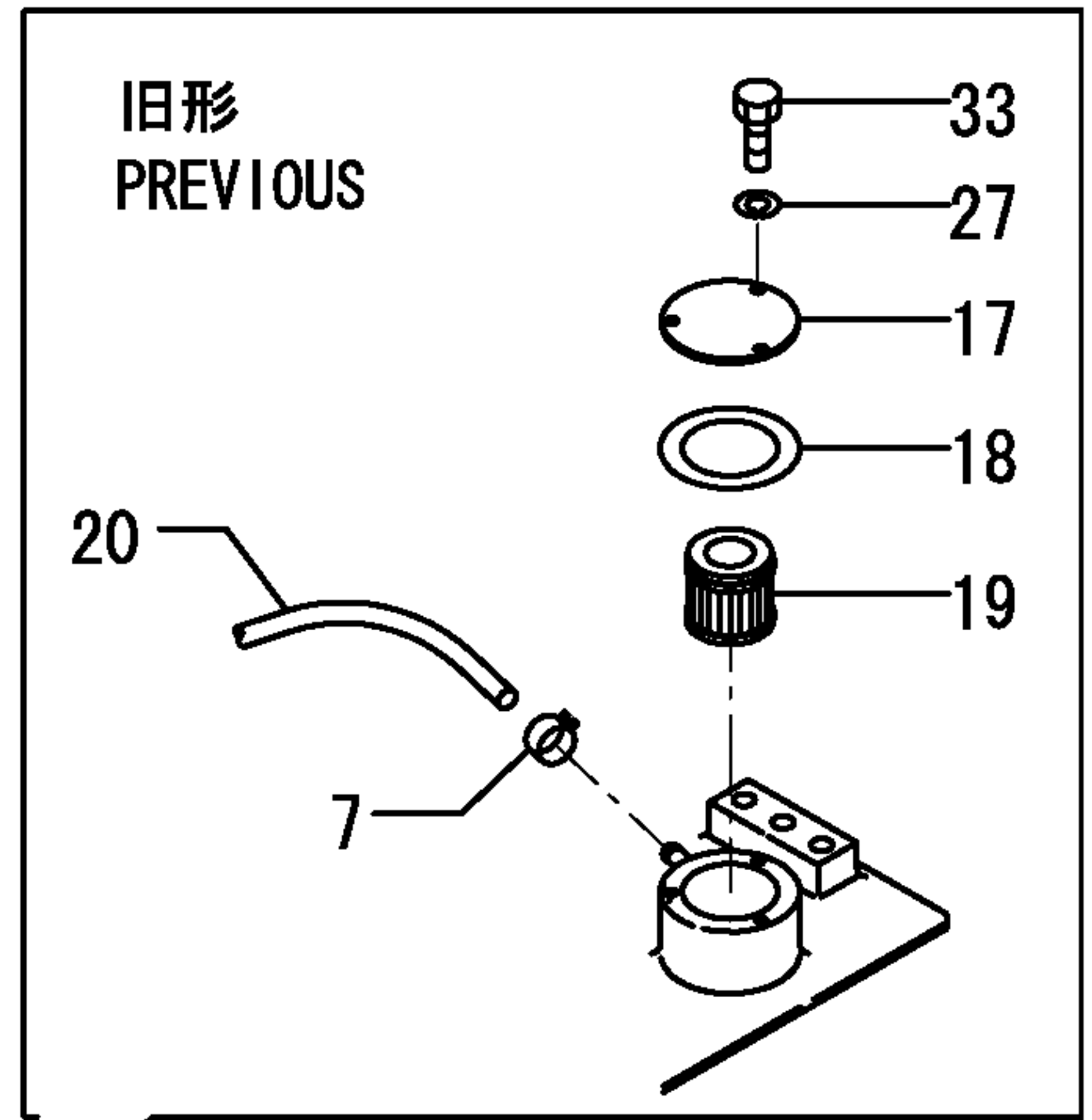



上から見  
VIEWED FROM UPPER

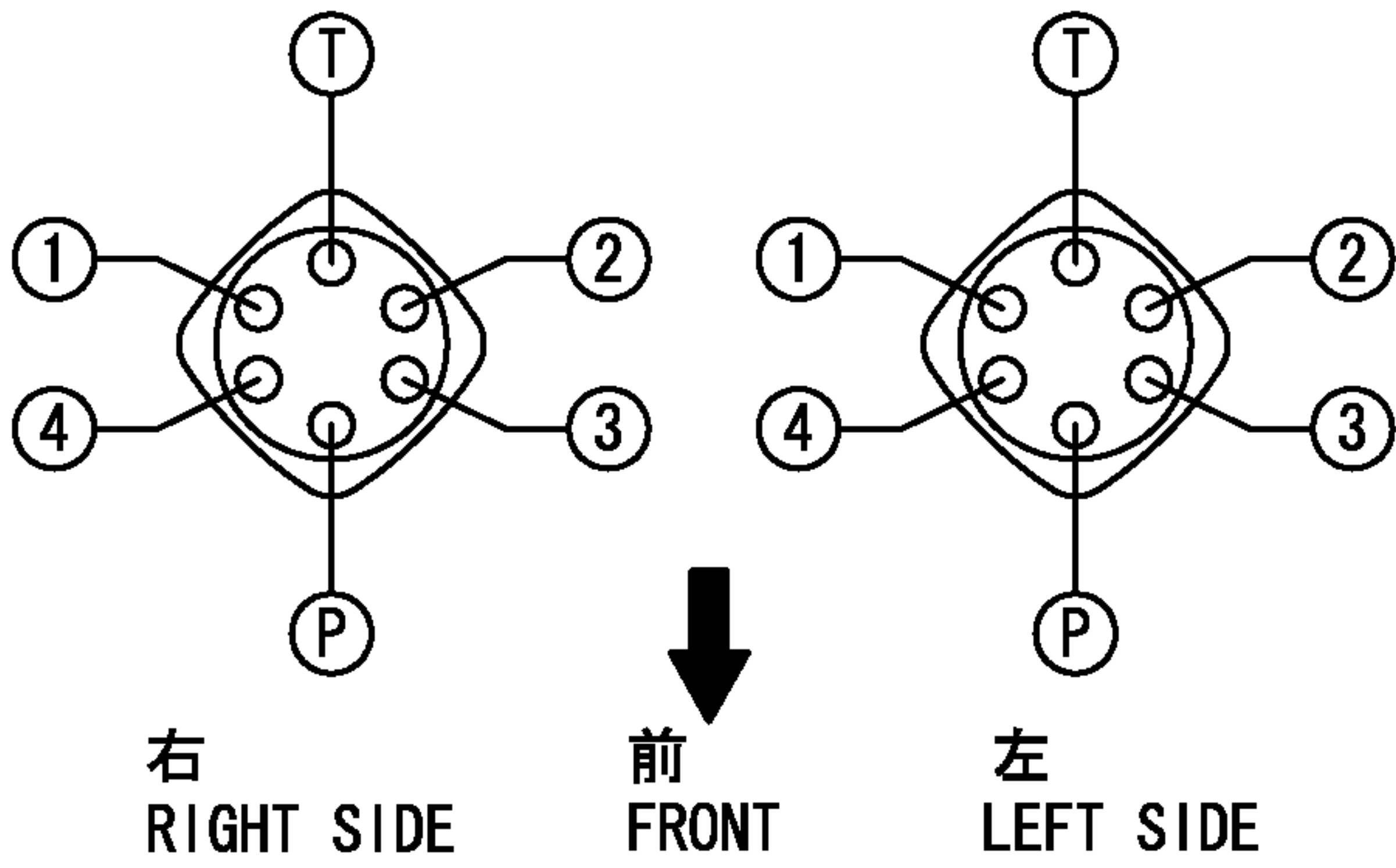

左側  
LEFT SIDE

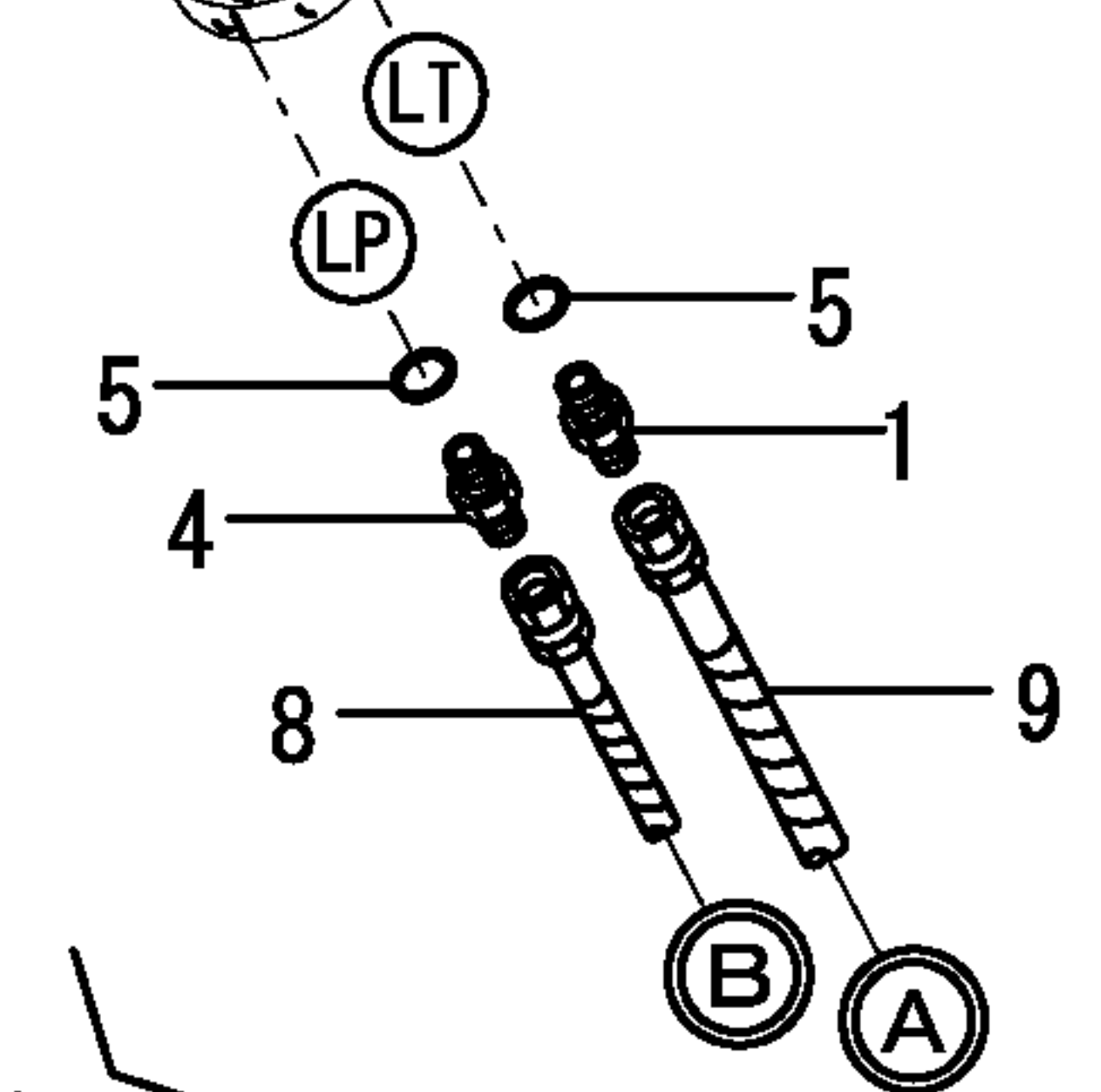

右側  
RIGHT SIDE

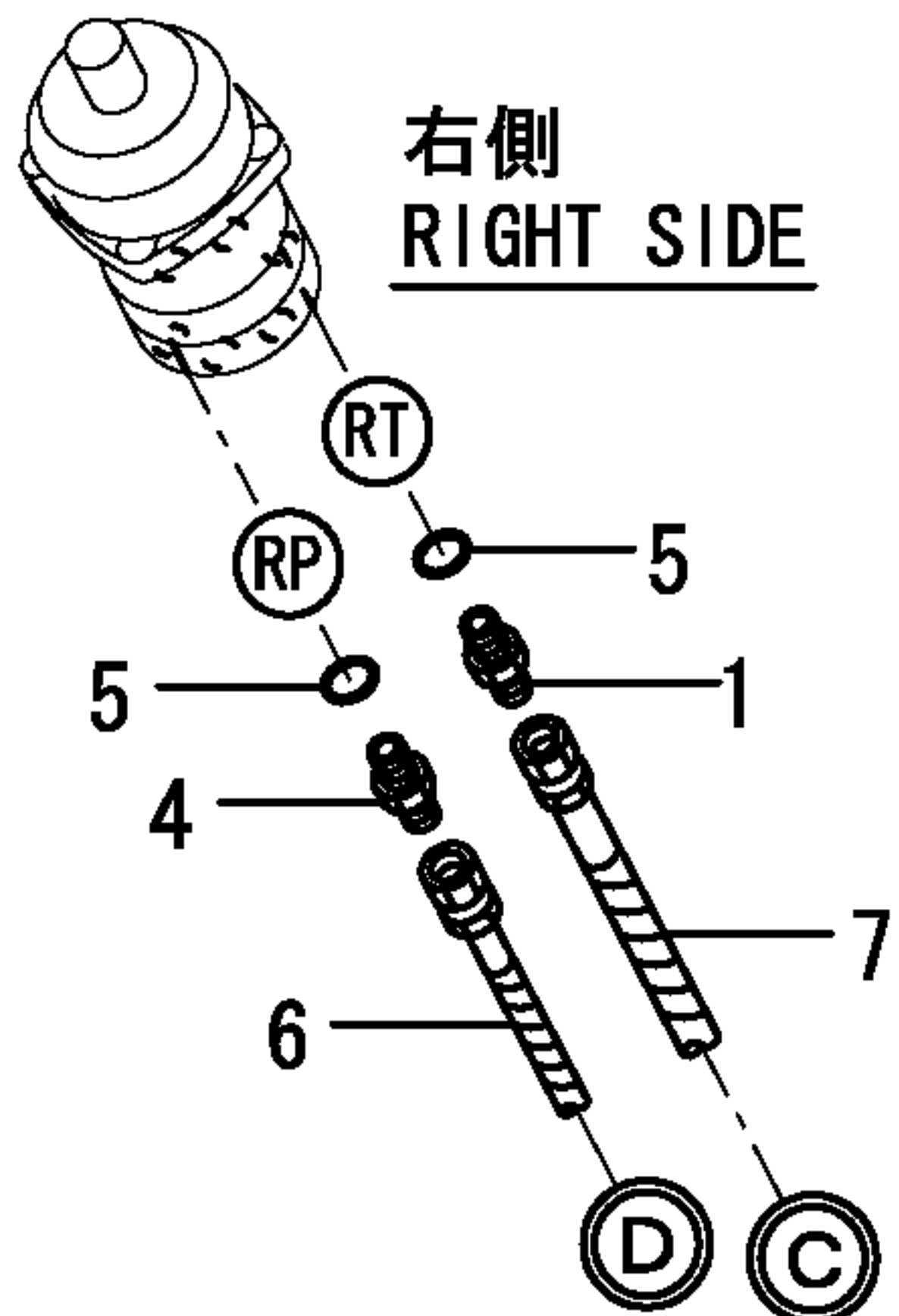

リモコンバルブ  
REMOTE CONTROL VALVE

リモコンバルブ  
REMOTE CONTROL VALVE

油圧ポンプ  
HYD. OIL PUMP

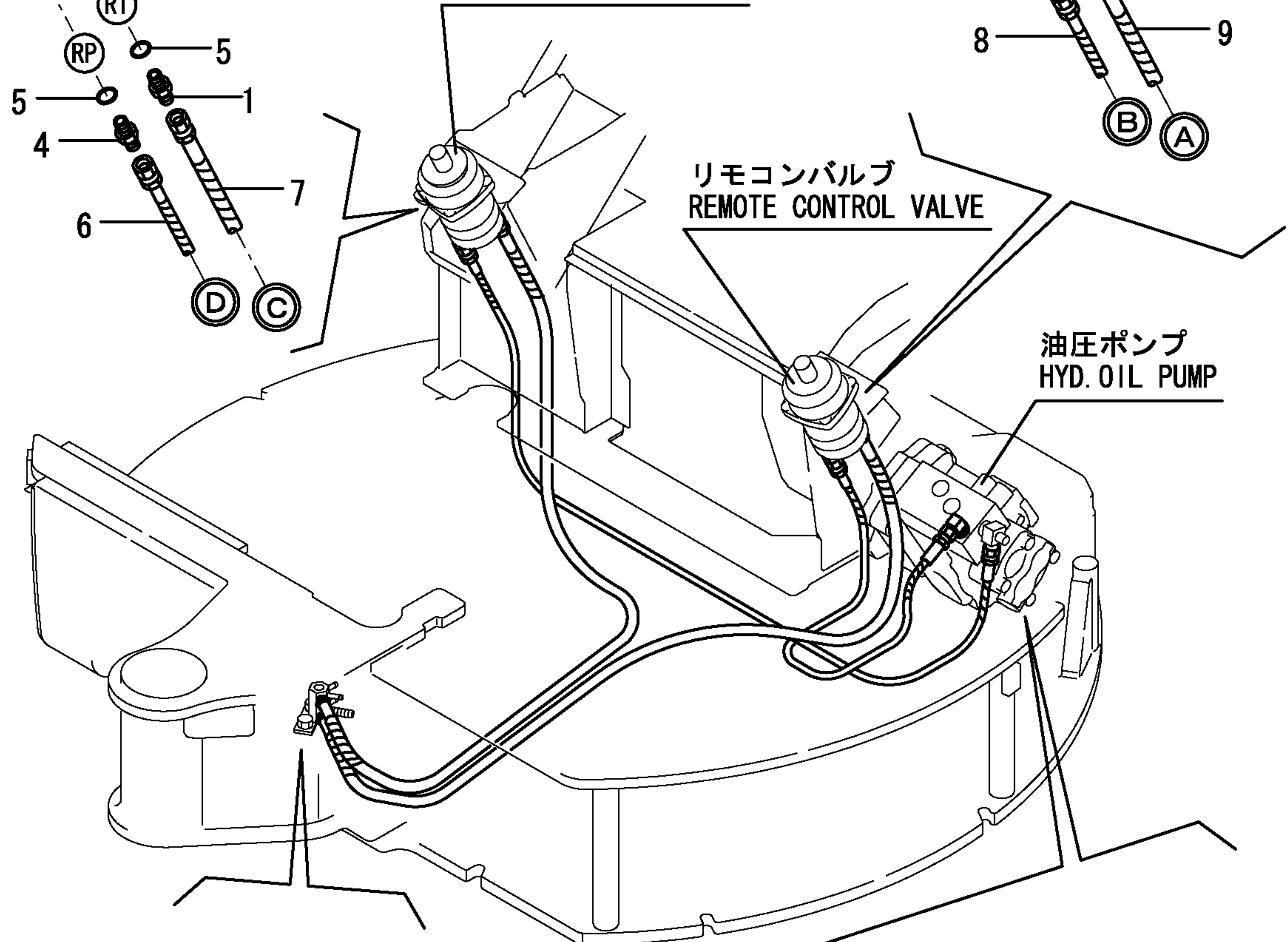

REFER TO Fig. 99

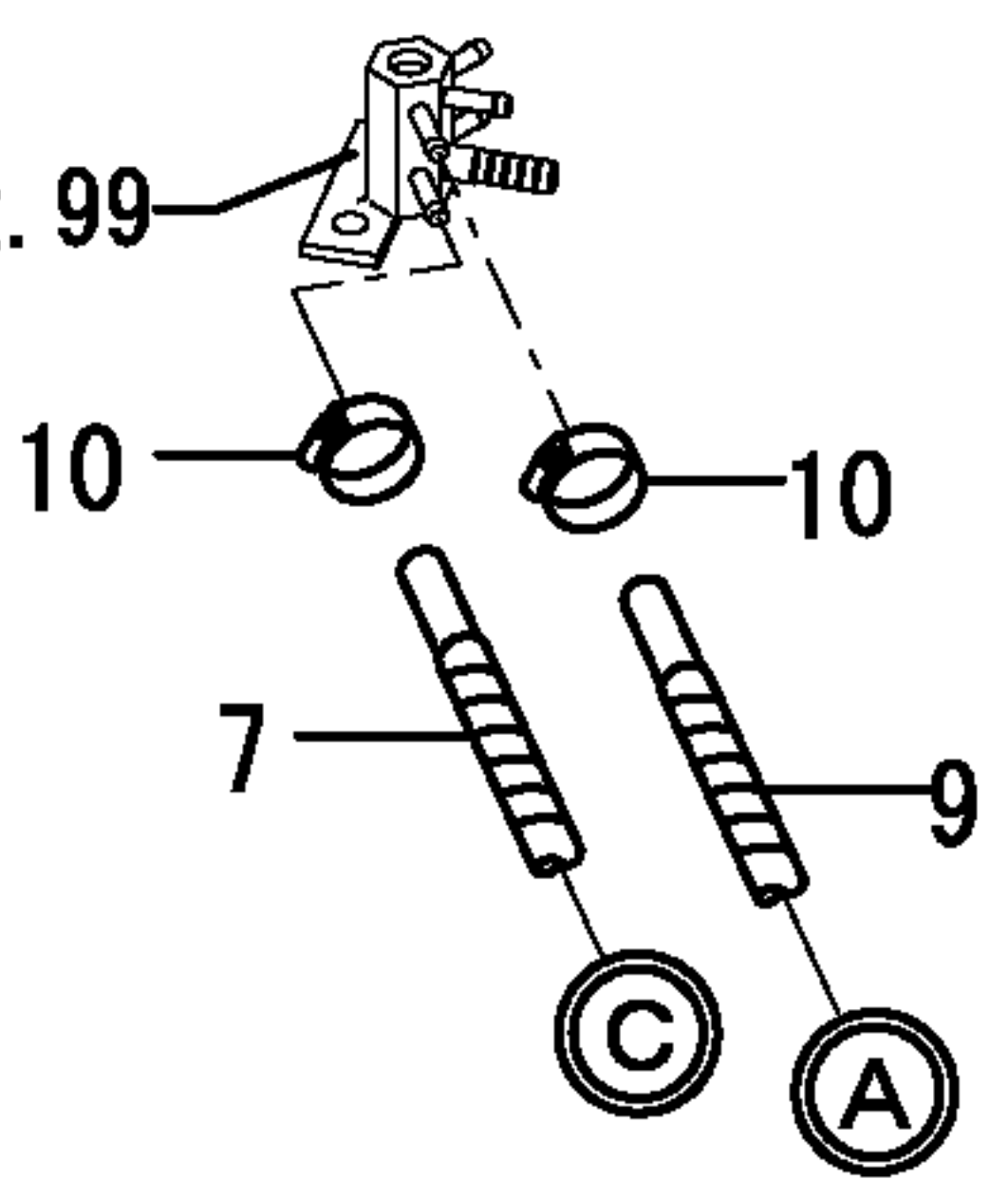

REFER TO Fig. 99

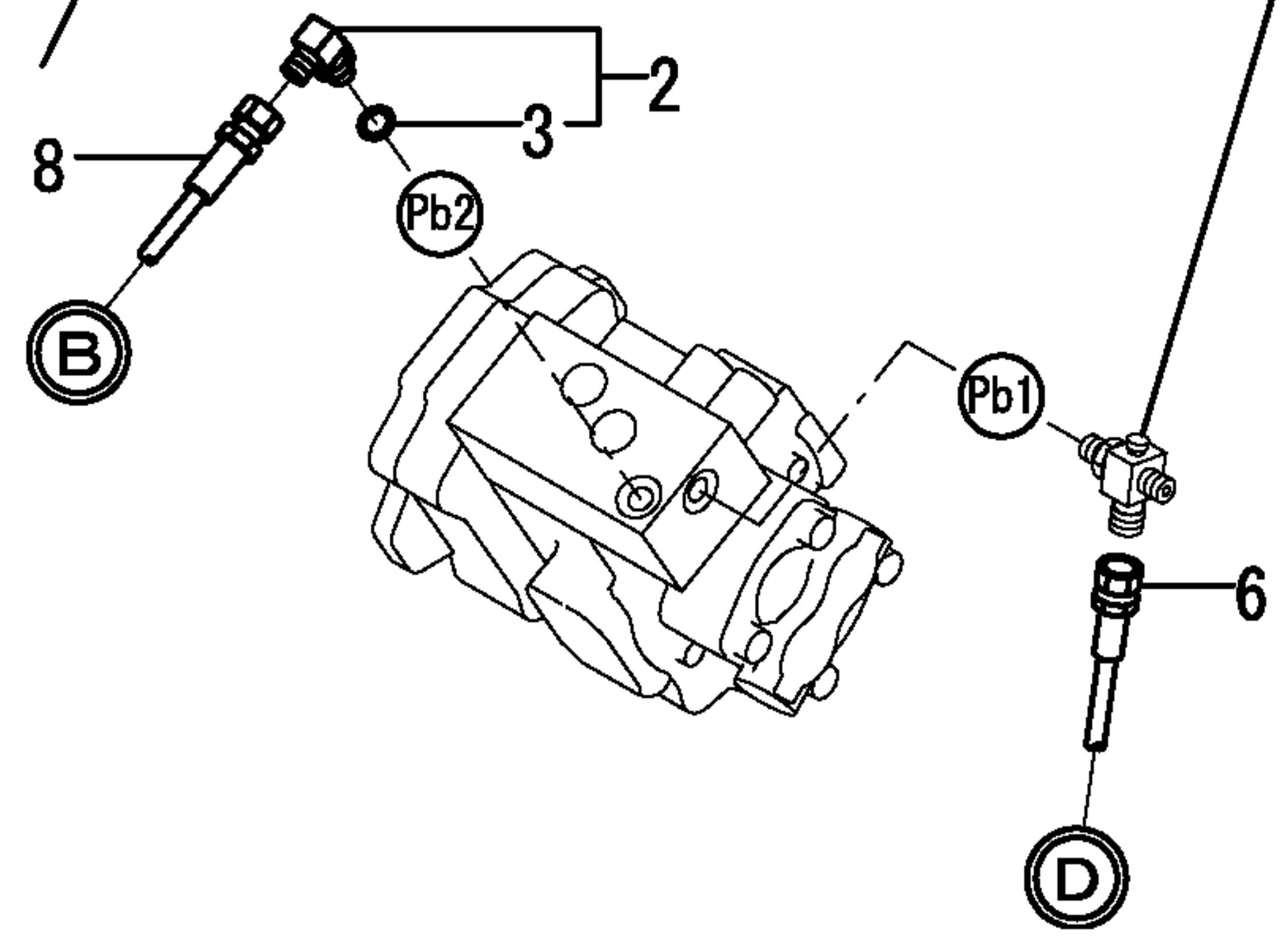

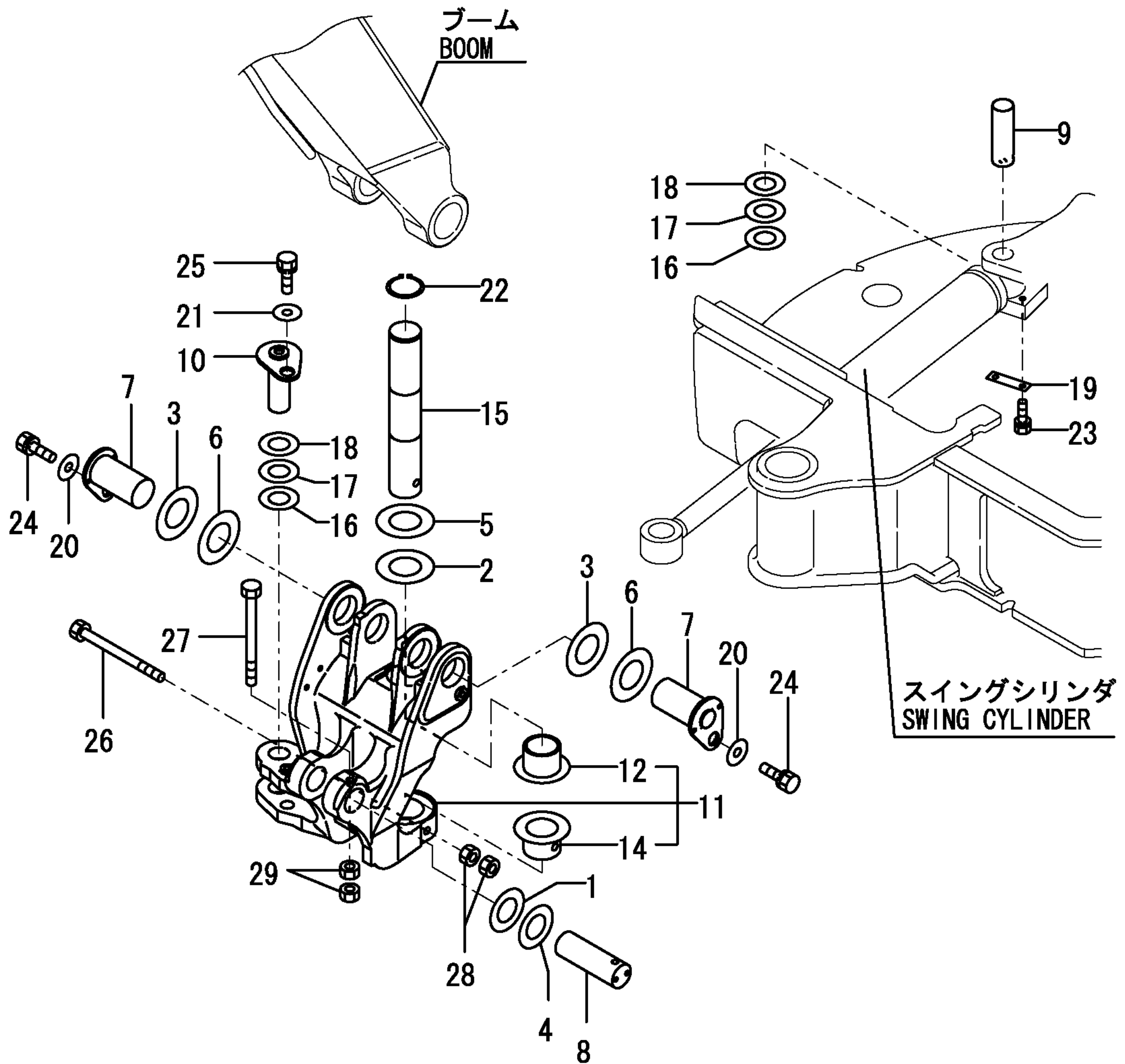

29,1,,26116-080204,, "BOLT M 8X 20 PLATED",2,2,,,,,,,,,,,,,  
29-1,1,,26116-080202,, "BOLT M 8X 20  
PLATED",3,3,3,,,,,K,,72958061,M/#20852,72958061,M/#20852,,,,,  
30,1,,22252-000250,, "CIRCLIP 25",2,2,2,,,,,,,,,,,,,  
31,1,,933171-29751,, "SHIM SET,38X(0.8,1.2",4,4,4,,,,,,,,,,,,,  
34,1,,172958-  
83291,, "PLATE,GUADE(GREEN:97",1,1,1,,,,,W,,72958053,M/#20808,72958053,M/#20808,,,  
''''  
35,1,,172141-84601,, "SHIM  
35",1,1,1,,,,,W,,72956014,M/#20784,72956014,M/#20784,,,,,  
39,1,,26013-080162,, "BOLT W/WASHER  
M8X16",2,2,2,,,,,W,,72956024,M/#20852,72956024,M/#20852,,,,,

1,1,,172457-08700,, "P.T.O. KIT(GREEN:97)",1,1,,,,,1,,,,,  
1-1,1,,172457-08701,, "P.T.O.  
KIT(GREEN:97)",1,1,,,,,S,2,72458168,M/#20610,72458168,M/#20610,,,,,  
2,2,,172458-03240,, "LABEL,LOCK",1,1,,,,,I  
3,2,,172458-03270,, LABEL,1,1,,,,,I  
3-1A,1,,172496-03210,, "LABEL,  
P.T.O.",1,1,,,,,N,3,724600328,M/#25501,724600328,M/#25501,,,,,I  
3-1B,1,,172490-03210,, "LABEL,  
P.T.O.",1,1,,,,,N,4,724600328,M/#25501,724600328,M/#25501,,,,,I  
4,2,,172068-28490,, "SPRING 8",2,2,,,,,I  
5,2,,172068-28490,, "SPRING 8",2,2,,,,,I  
6,2,,172110-36010,, COLLAR,2,2,,,,,I  
7,2,,194200-37780,, "LS-NUT 8",1,1,,,,,I  
8,2,,172734-41300,, "LINK BALL 8L",1,1,,,,,I  
9,2,,172142-43591,, "ROD,465",1,1,,,,,I  
10,2,,172823-45000,, "ROD 54, SPOOL",1,1,,,,,I  
11,2,,1A1040-45890,, "WASHER 10 36 4.5",2,2,,,,,I  
12,2,,172458-46100,, "LINK A ASSY, P.T.O.",1,1,,,,,I  
13,3,,172141-41370,, "BUSH 2015",2,2,,,,,I  
14,3,,172458-46110,, "LINK A, P.T.O.",1,1,,,,,I  
15,2,,172458-46121,, "LINK B ASSY, P.T.O.",1,1,,,,,I  
16,3,,172141-41370,, "BUSH 2015",2,2,,,,,I  
17,3,,172458-46131,, "LINK ASSY,PTO B",1,1,,,,,I  
18,2,,172458-46150,, "BRACKET,P.T.O. (72)",1,1,,,,,I  
19,2,,172124-46200,, "O-RING 27X5.7",4,4,,,,,I  
20,2,,172458-46230,, "PEDAL A (GRAY:72)",1,1,,,,,I  
21,3,,172141-41360,, "BUSH 1415",2,2,,,,,I  
22,3,,172110-45050,, "BUSH 12X12",2,2,,,,,I  
23,3,,172458-46240,, "PEDAL ASSY, A",1,1,,,,,I  
24,2,,172458-46280,, "PEDAL B (72)",1,1,,,,,I  
25,2,,172458-46290,, PLATE,1,1,,,,,I  
26,2,,172458-46350,, "PLATE,LOCK (GRAY:72)",1,1,,,,,I  
27,2,,172458-46371,, "BASE,PEDAL(BLACK:12)",1,1,,,,,I  
28,3,,172458-46171,, "PEDAL ASSY, BASE",1,1,,,,,I  
29,3,,172458-46380,, RUBBER,1,1,,,,,I  
30,2,,172187-46400,, "BRACKET (GRAY:73)",1,1,,,,,I  
31,2,,172187-46430,, SHAFT,1,1,,,,,I  
32,2,,172122-46590,, "ELBALL 8",4,4,,,,,I  
33,2,,172116-46630,, "KNOB, LOCK LEVER",1,1,,,,,I  
34,2,,172183-74820,, "STOP VALVE",2,2,,,,,I  
35,2,,172633-76160,, "ADAPTER 1/2-3/4",1,1,,,,,I  
36,2,,172422-76180,, CONNECTOR,1,1,,,,,I  
37,2,,172422-76190,, CONNECTOR,1,1,,,,,I  
38,2,,172183-76250,, "PLATE (GREEN:97)",2,2,,,,,I  
39,2,,172142-76270,, "JOINT 1/2, SWIVEL",1,1,,,,,I  
40,3,,172142-77040,, "SEAL SET",1,1,,,,,I  
41,2,,172142-76280,, "JOINT 3/4, SWIVEL",1,1,,,,,I  
42,3,,172142-77050,, "SEAL SET",1,1,,,,,I  
43,2,,172457-76601,, "TUBE L,P.T.O. (97)",1,1,,,,,I  
44,2,,172457-76650,, "TUBE R,P.T.O(GREEN97)",1,1,,,,,I  
45,2,,172458-76680,, "STAY (GREEN:97)",2,2,,,,,I  
46,2,,172458-76700,, "JOINT ASSY, P.T.O.",1,1,,,,,I  
47,2,,172457-76770,, "PLATE,PIPE(GREEN:97)",1,1,,,,,I  
47-1,2,,172458-  
76750,, "PLATE,PIPE(GREEN:97)",1,1,,,,,S,,72458168,M/#20610,72458168,M/#20610,,,,,  
,,,,,I  
48,2,,172458-76800,, "TUBE,FRAME-END",1,1,,,,,I  
49,2,,172458-76880,, PLATE,1,1,,,,,I  
50,2,,172125-76900,, "CLAMP (YELLOW:87)",1,1,,,,,I  
51,2,,172142-76940,, "CLAMP 3/4(YELLOW:87)",2,2,,,,,I  
52,2,,172142-76950,, "CLAMP 1/2(YELLOW:87)",2,2,,,,,I  
53,2,,172457-78900,, "HOSE G212BB083W",1,1,,,,,I  
54,2,,172957-78900,, "HOSE G212BB077W",1,1,,,,,I

CLICK HERE TO **DOWNLOAD** THE COMPLETE MANUAL

- Thank you very much for reading the preview of the manual.
- You can download the complete manual from: [www.heydownloads.com](http://www.heydownloads.com) by clicking the link below



- Please note: If there is no response to CLICKING the link, please download this PDF first and then click on it.

CLICK HERE TO **DOWNLOAD** THE COMPLETE MANUAL