

P R E F A C E

1. This Parts Catalog is the 1st revised of Yanmar crawler back-hoe B12-3 for Europe.

2. Parts catalog history

	Parts catalog NO.	Published	Note
1st edition	000Y00S3980	Jun., 2000	Disuse old edition
1st revised	000Y00S3981	Jul., 2002	

3. Model name

SECTION	Column	Model name	Manufactured	M/#
I (Vehicle)	(A)	B12-3	2000/7~	
II (Engine)	(A)	3TN66L-EUBA	2000/4~	81954~

4. Your understanding is asking that this parts catalog is not a technical data manual setting forth as servicing procedures, This parts catalog is using simplified illustration. Be sure to use Yanmar Genuine Parts in your maintenance servicing of Yanmar products. Be careful not to use the simple parts available in the market, otherwise their use in repairing causes such as an early breakage, for instance.

CLICK HERE TO **DOWNLOAD** THE COMPLETE MANUAL

- Thank you very much for reading the preview of the manual.
- You can download the complete manual from: www.heydownloads.com by clicking the link below



- Please note: If there is no response to CLICKING the link, please download this PDF first and then click on it.

CLICK HERE TO **DOWNLOAD** THE COMPLETE MANUAL

PICTURESQUE INDEX (3) . . . FIGURE

Fig. 49 ARM

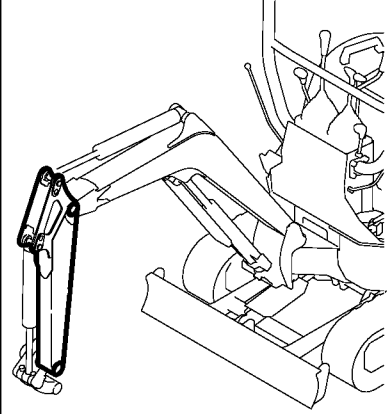

Fig. 50 BUCKET ARM & LINK
(PREVIOUS)

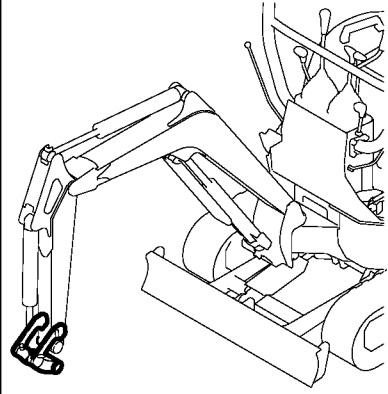

Fig. 51 BUCKET ARM & LINK (NEW)

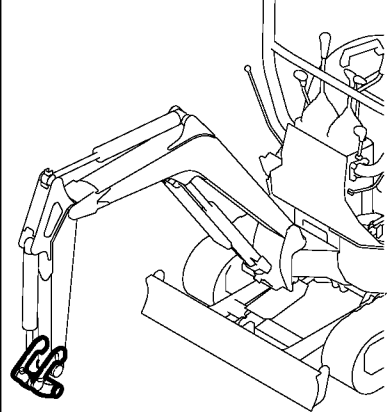
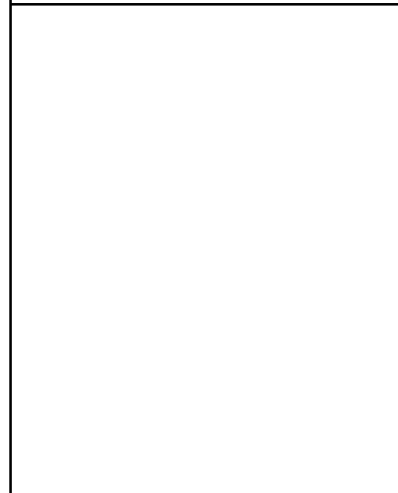
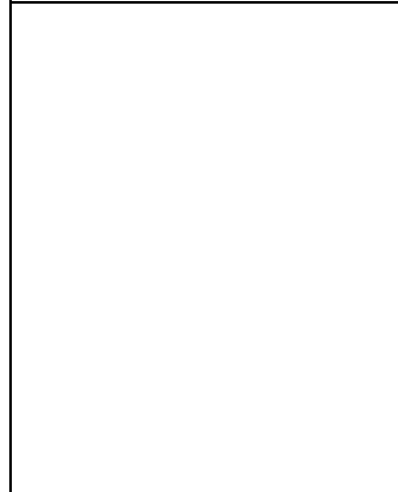
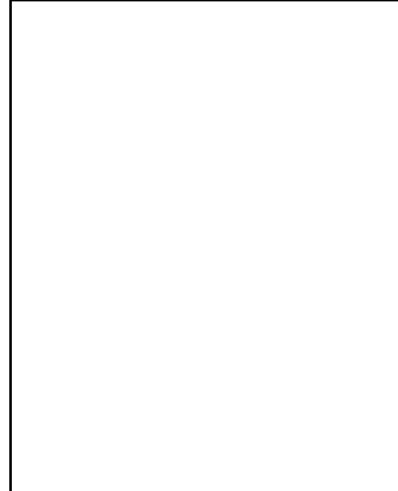
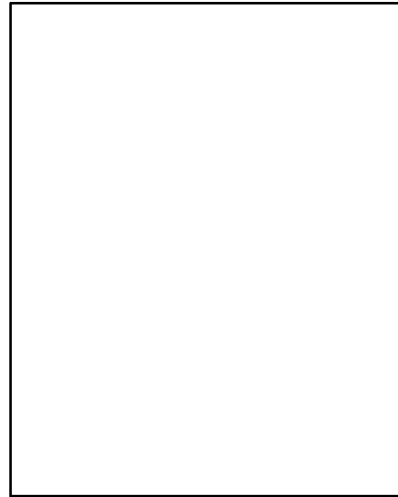
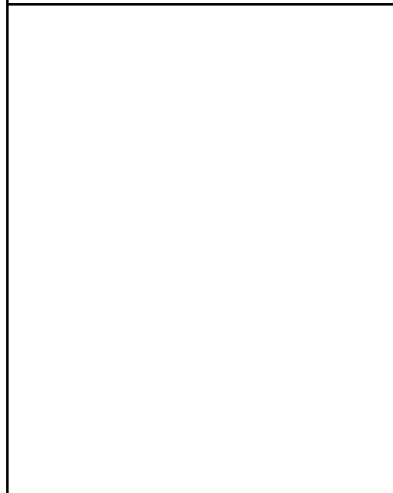
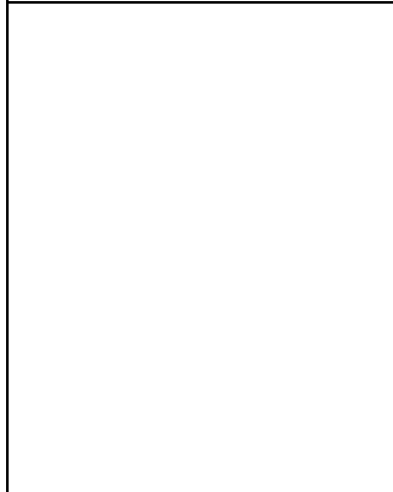
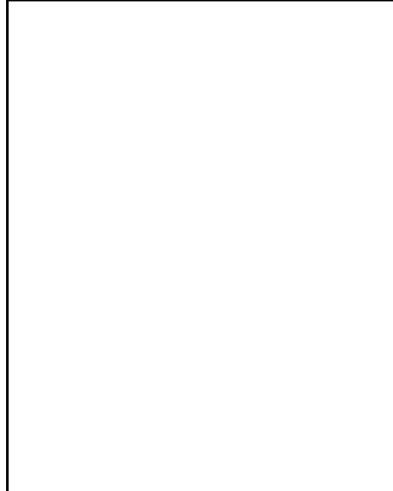
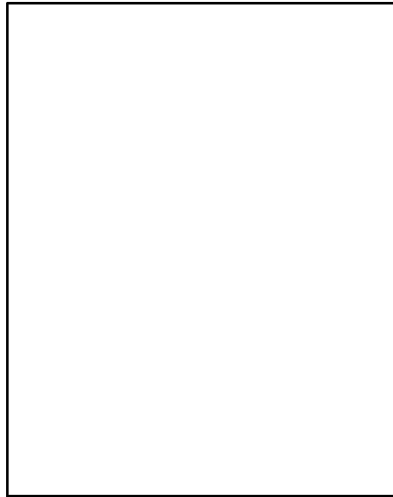
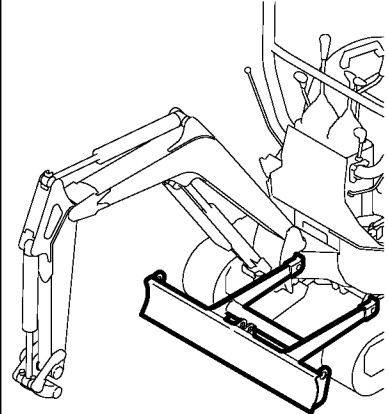
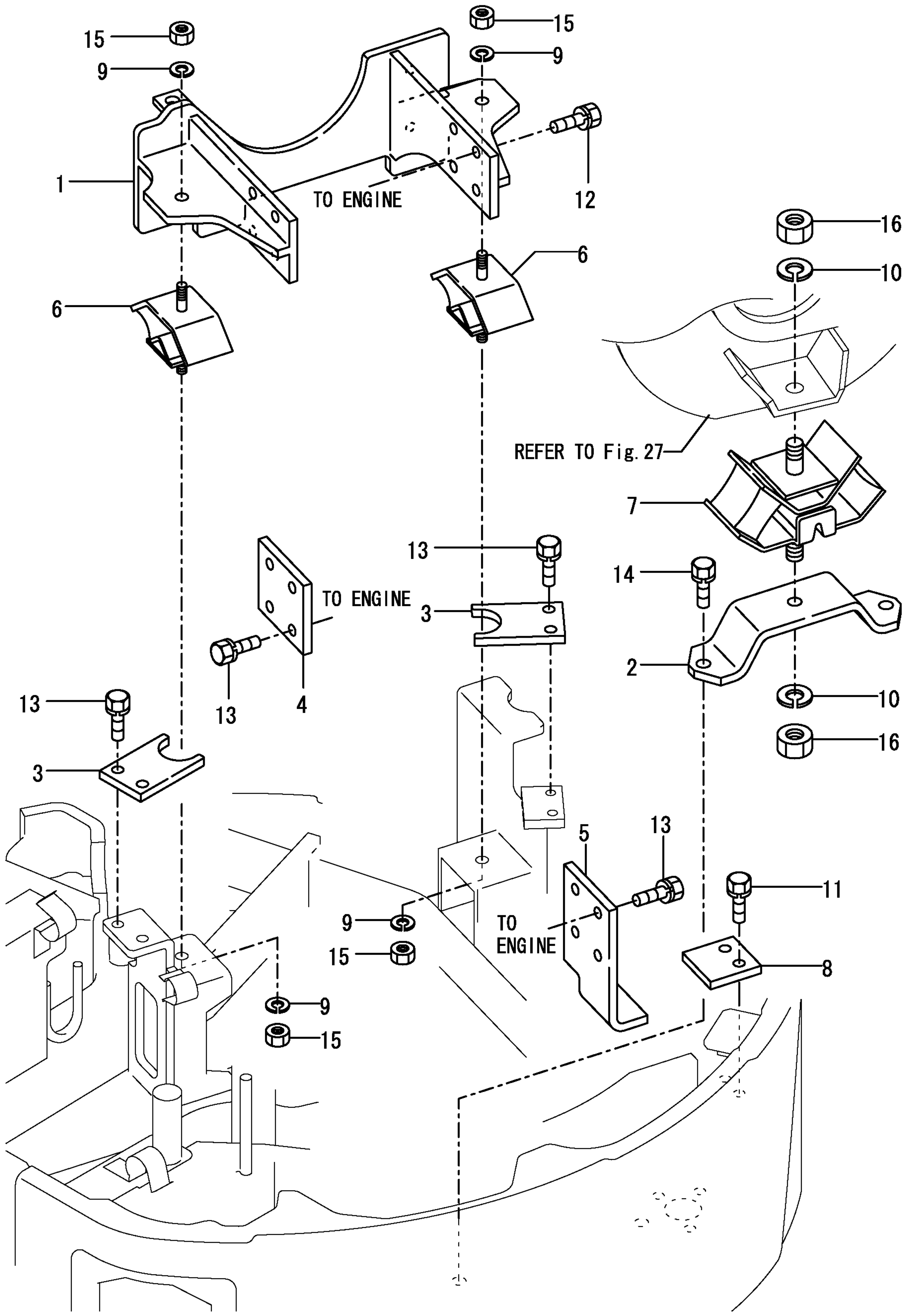
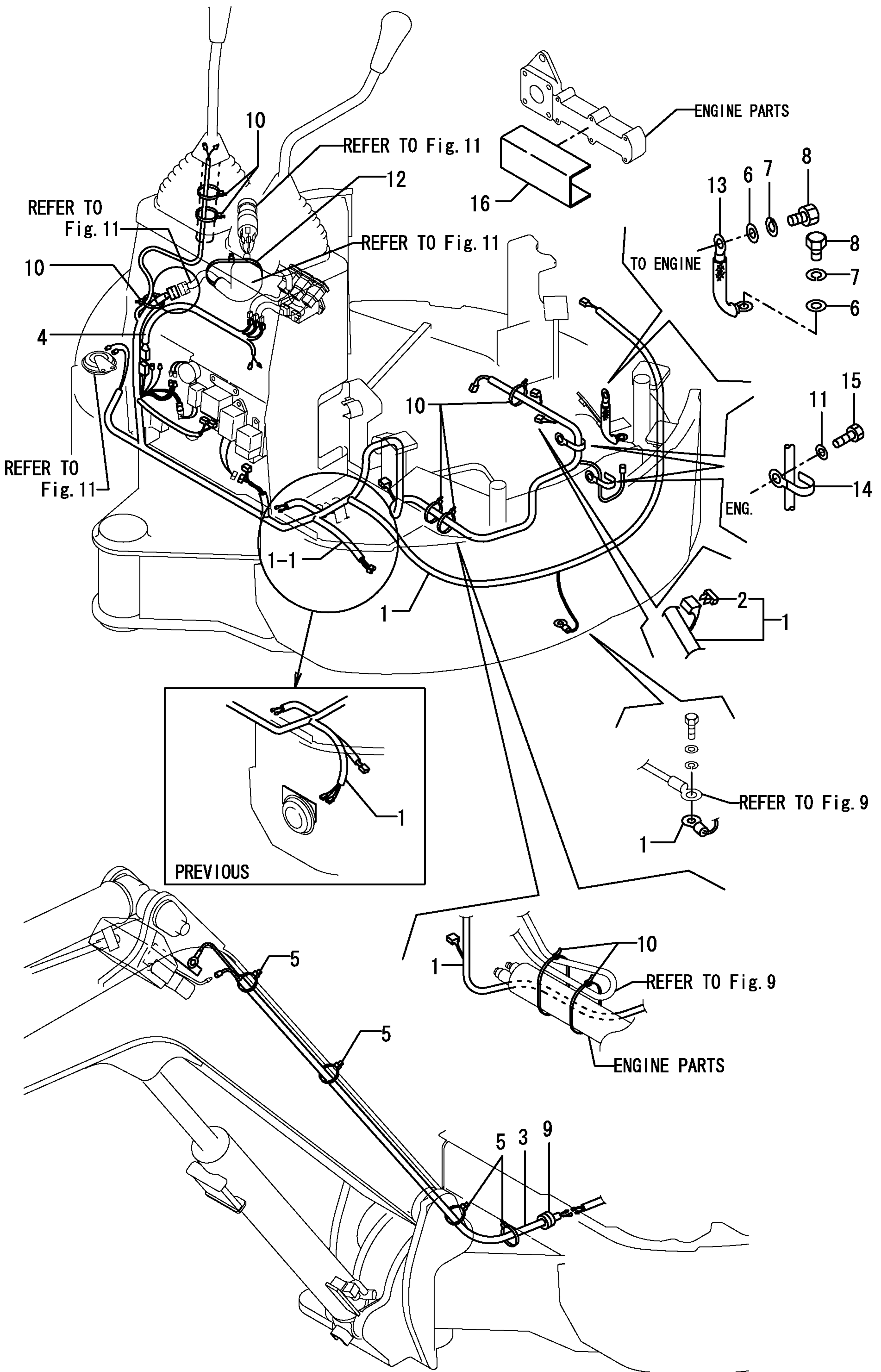
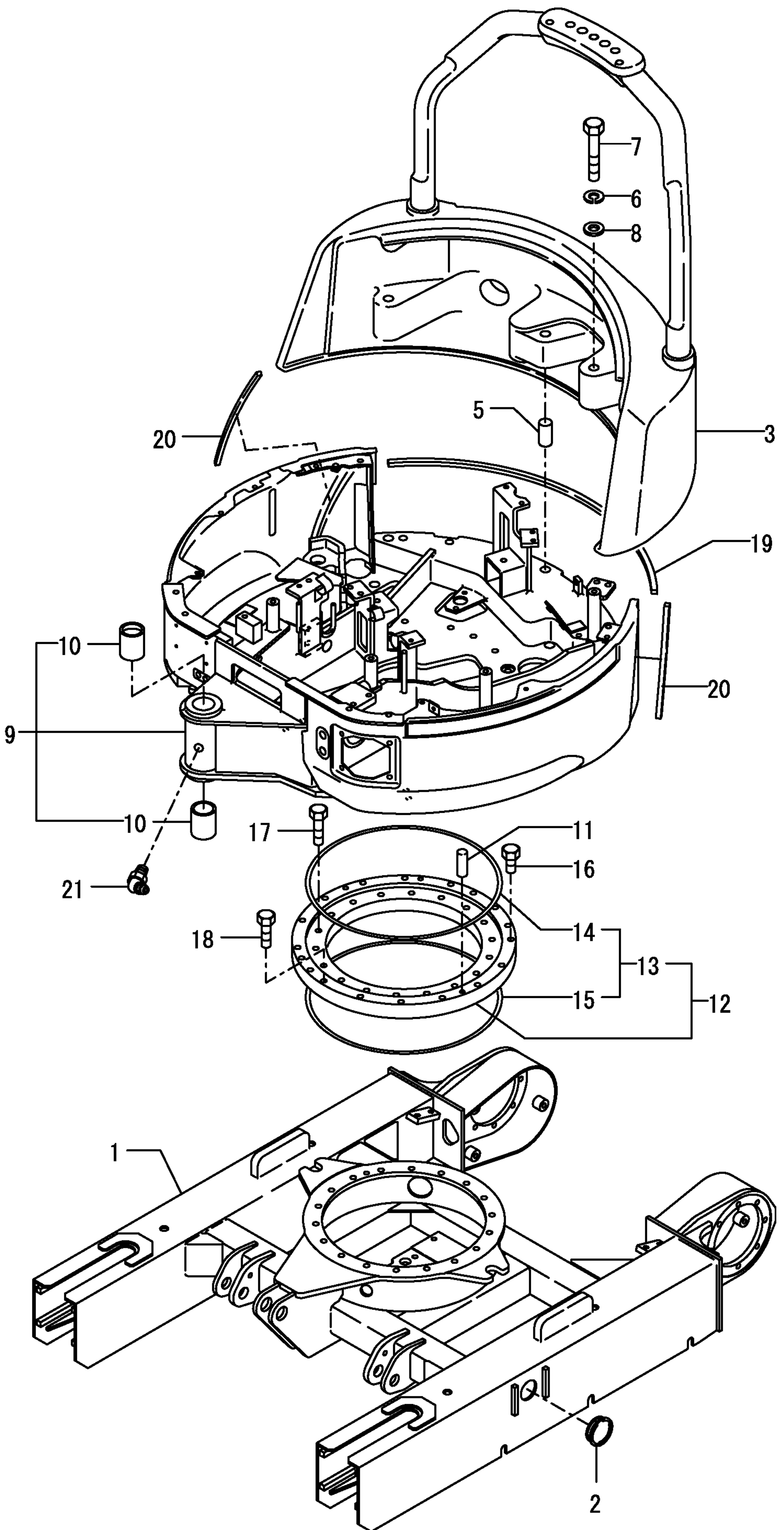

Fig. 52 BLADE









CLICK HERE TO **DOWNLOAD** THE COMPLETE MANUAL

- Thank you very much for reading the preview of the manual.
- You can download the complete manual from: www.heydownloads.com by clicking the link below



- Please note: If there is no response to CLICKING the link, please download this PDF first and then click on it.

CLICK HERE TO **DOWNLOAD** THE COMPLETE MANUAL

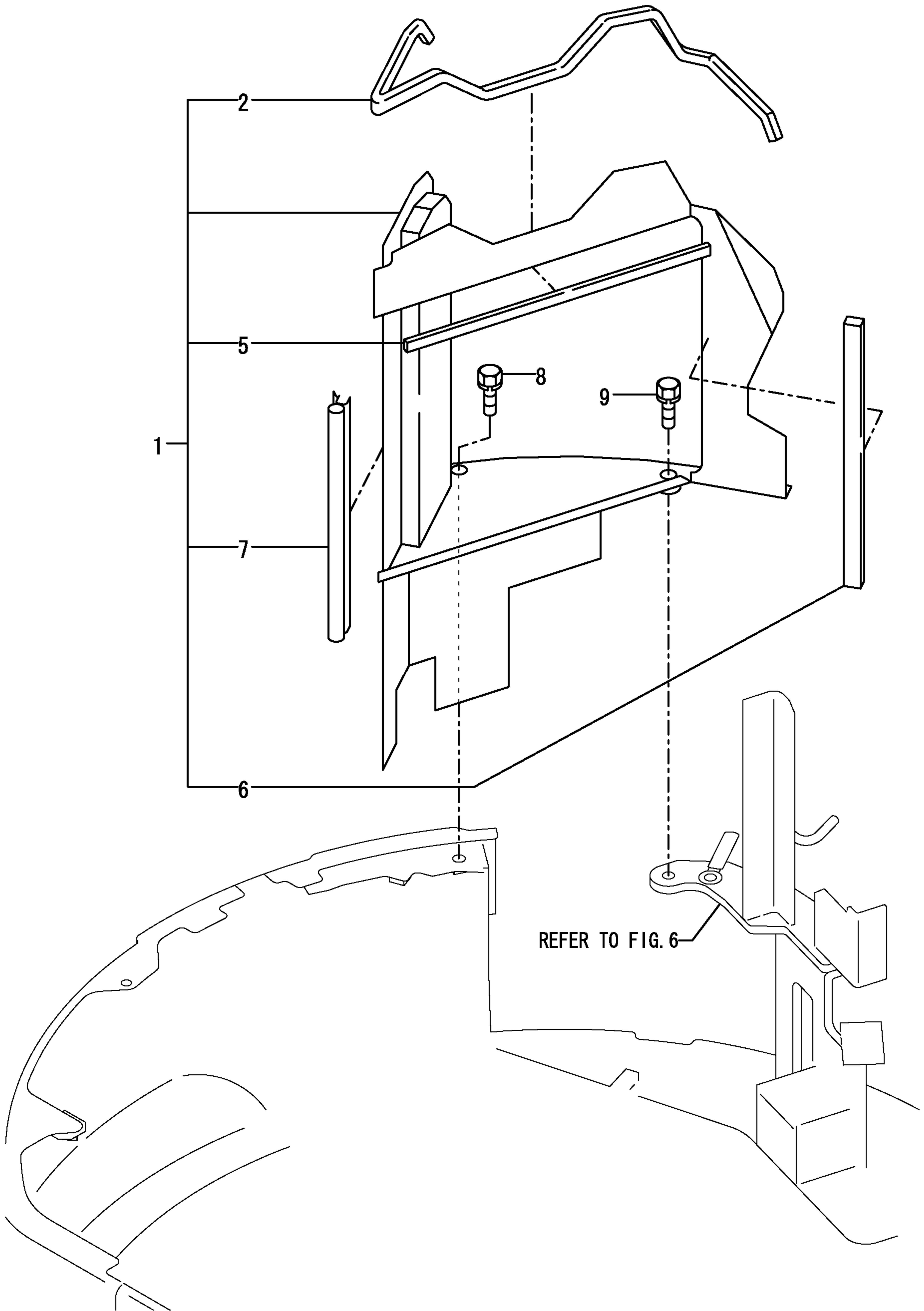

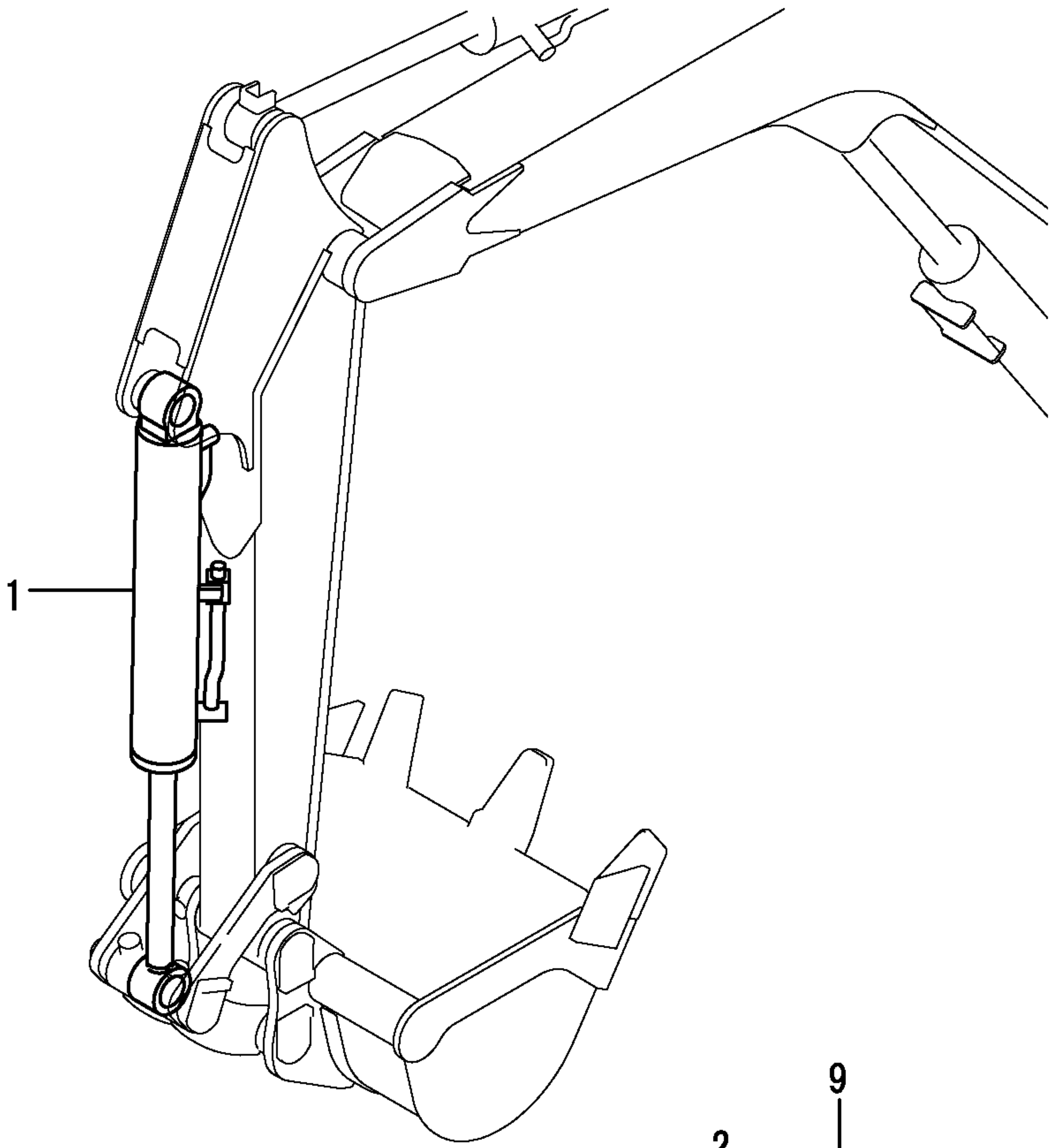

1 INC. 2~18.

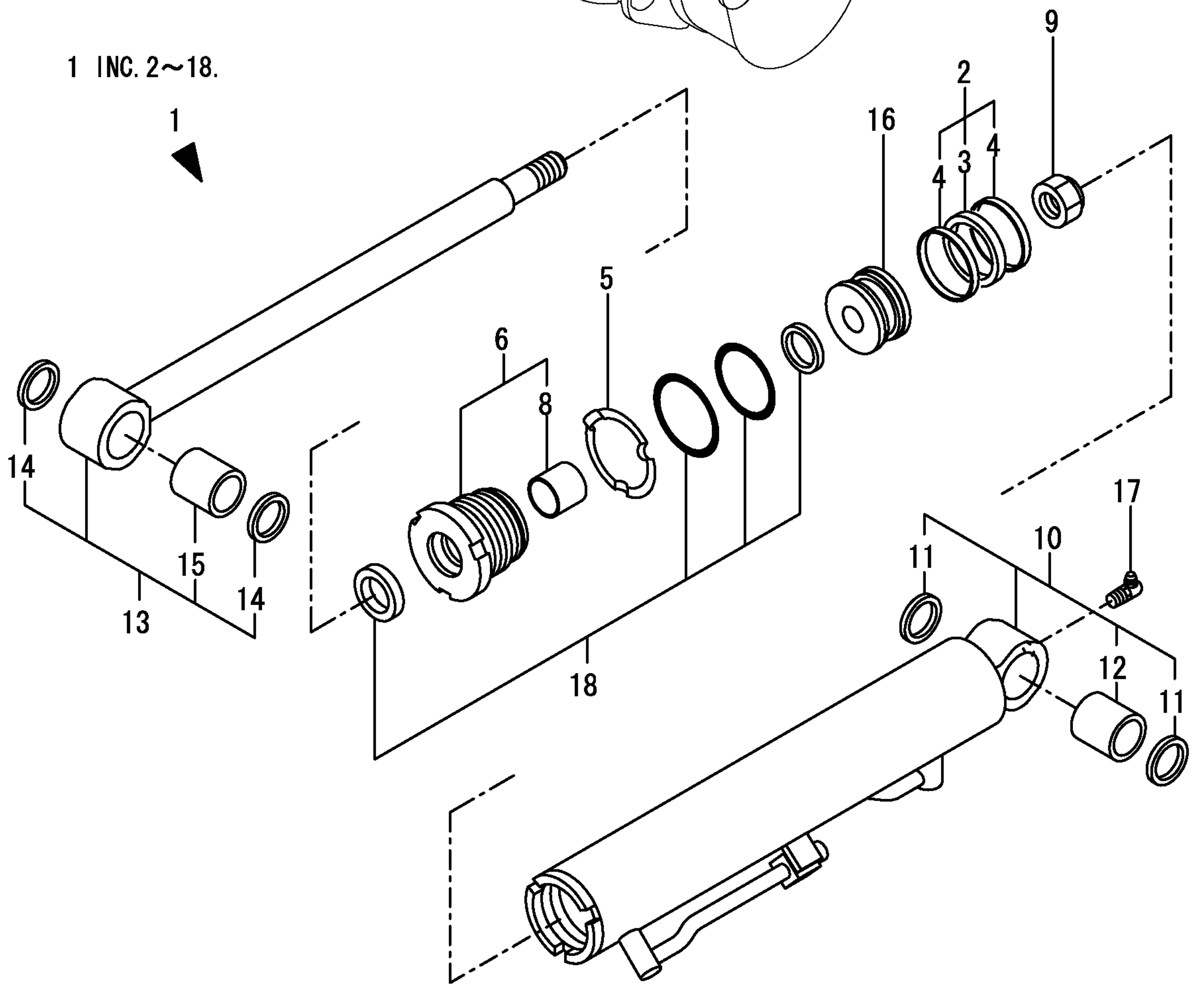

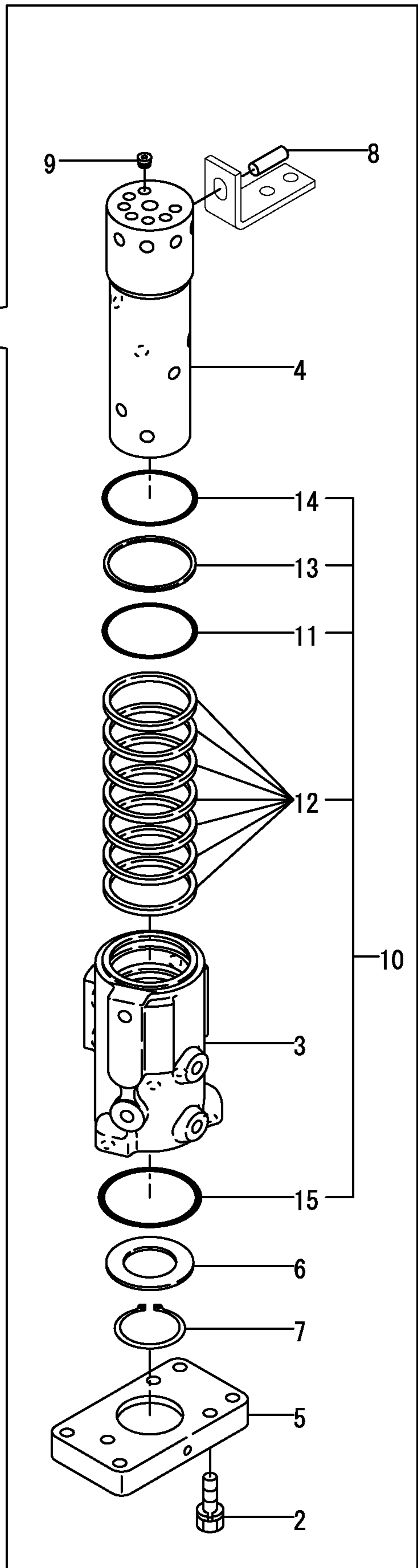
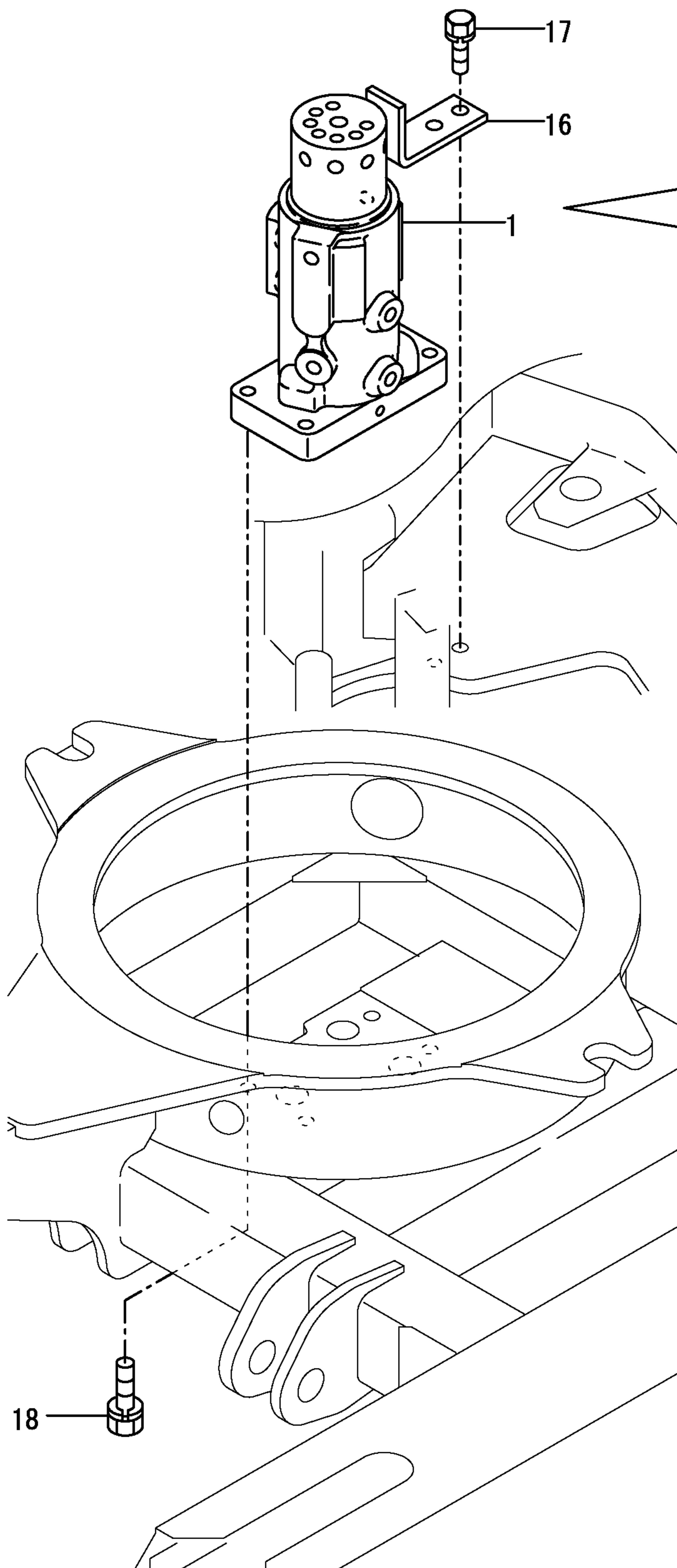

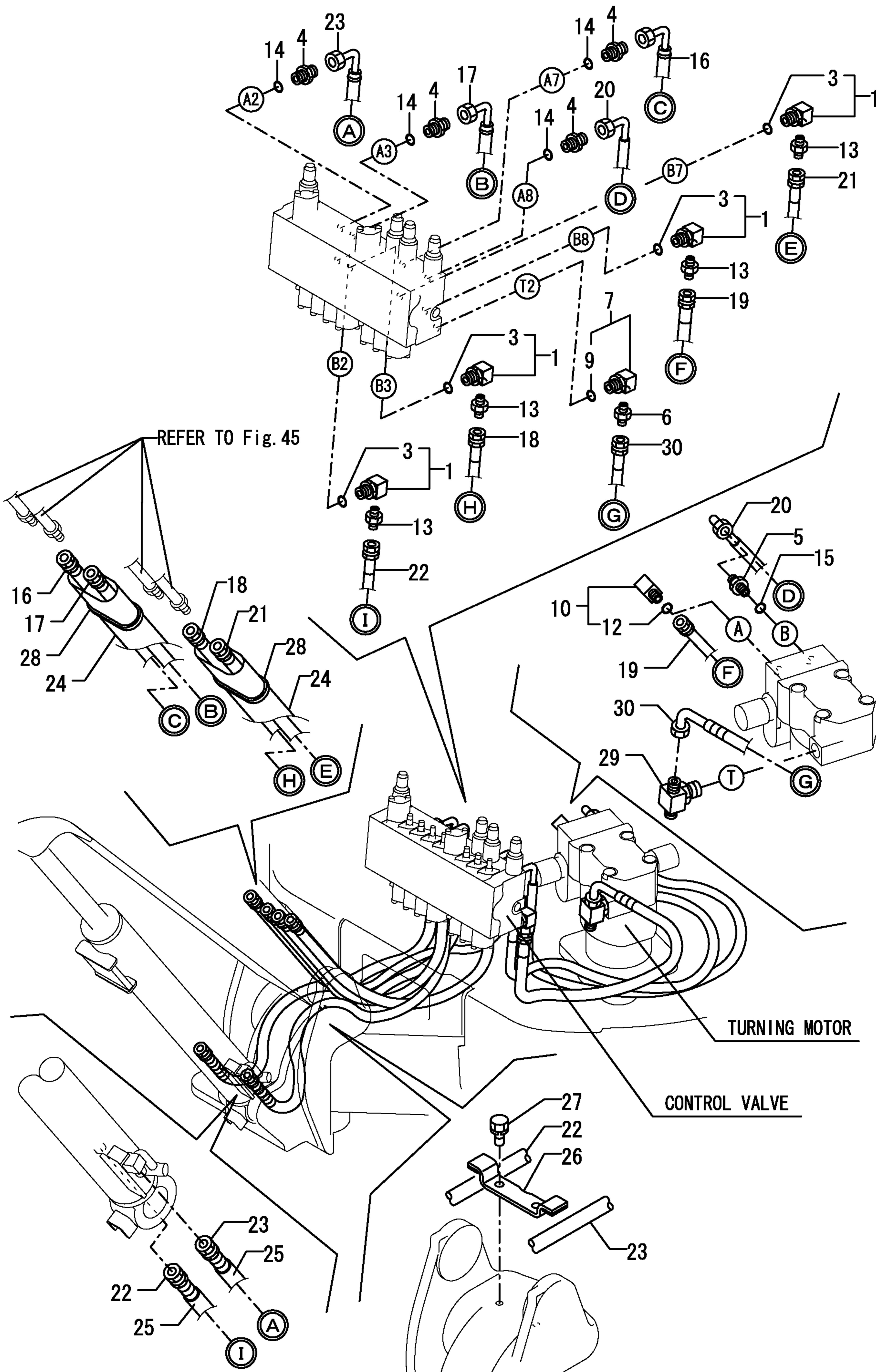

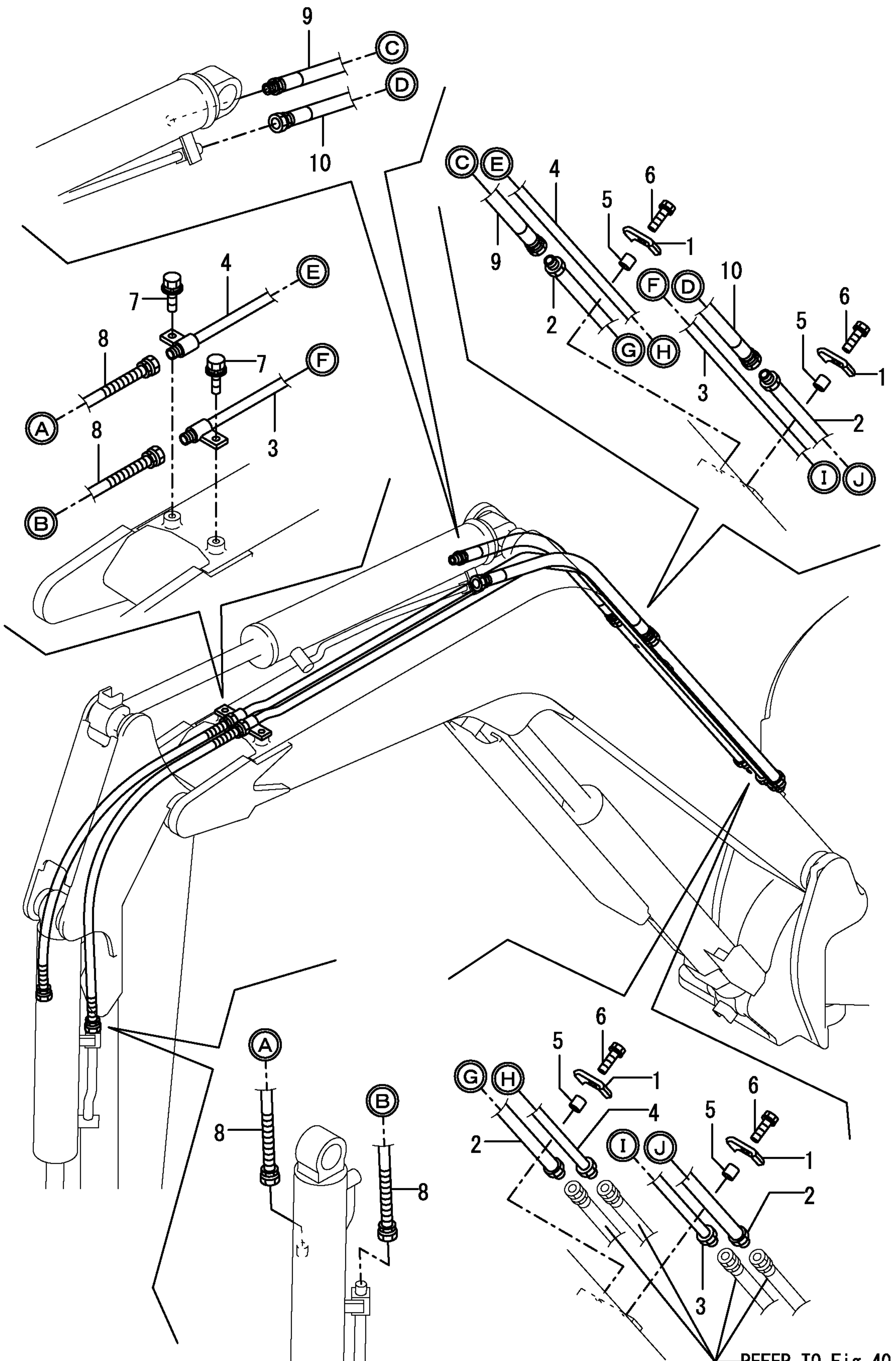

REFER TO Fig. 40

CLICK HERE TO **DOWNLOAD** THE COMPLETE MANUAL

- Thank you very much for reading the preview of the manual.
- You can download the complete manual from: www.heydownloads.com by clicking the link below



- Please note: If there is no response to CLICKING the link, please download this PDF first and then click on it.

CLICK HERE TO **DOWNLOAD** THE COMPLETE MANUAL