

ERC20-30AGF

(E108)

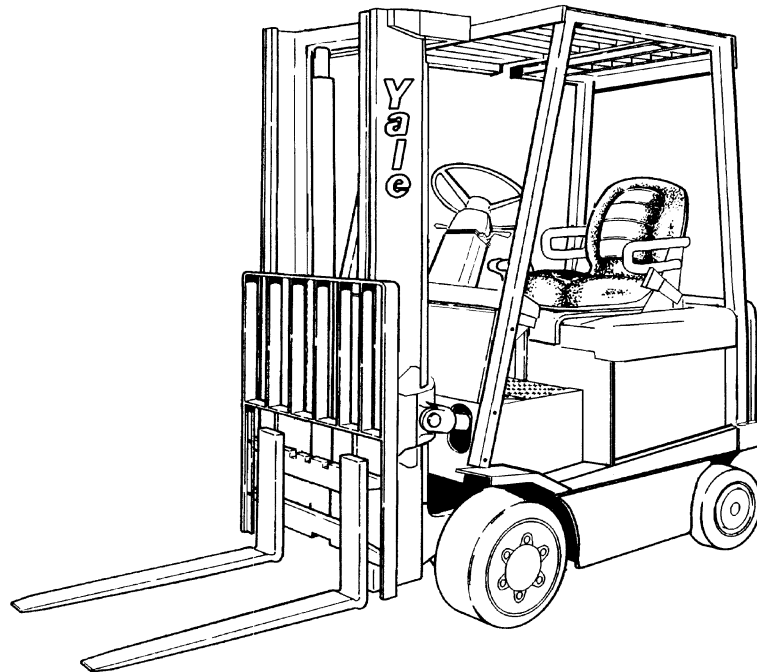

YP990017

CLICK HERE TO **DOWNLOAD** THE COMPLETE MANUAL

- Thank you very much for reading the preview of the manual.
- You can download the complete manual from: www.heydownloads.com by clicking the link below



- Please note: If there is no response to CLICKING the link, please download this PDF first and then click on it.

CLICK HERE TO **DOWNLOAD** THE COMPLETE MANUAL

DESCRIPTION	PAGE NO.
V	
VALVE ATTACHING PARTS	6.10
W	
WHEEL AND TIRE	4.48
DRIVE	3.10
WIRE HARNESS	
CONTACTOR HYDRAULIC	
⇒S/N E108A-02263W	2.128
CONTACTOR HYDRAULIC DASH DISPLAY	
PREMIUM TRUCK	
⇒S/N E108A-02263W	2.118
CONTROL VALVE SWITCH	
S/N E108A-02264W⇒	2.140
DASH DISPLAY	2.120
ECONOMY TRUCK	
⇒S/N E108A-02263W	2.114
PREMIUM TRUCK	
⇒S/N E108A-02263W	2.112
⇒S/N E108A-02263W	2.142
FORWARD/REVERSE	
POWER STEERING ON DEMAND	
⇒S/N E108A-02263W	2.110
WITHOUT ON-DEMAND STEERING	
⇒S/N E108A-02263W	2.108
LIGHT	
12-VOLT	
D/B 07/1998⇒	11.35
⇒D/B 07/1998	11.34
⇒D/B 11/1997	2.122
D/B 11/1997⇒ S/N E108A02263W.....	2.124
S/N E108A-02264W⇒	2.138
MAIN	
⇒D/B 11/1997	2.132
D/B 11/1997⇒ S/N E108A02263W.....	2.134
S/N E108A-02264W⇒	2.136
SCR HYDRAULIC	
⇒S/N E108A-02263W	2.130
STEERING MOTOR	
D/B 11/1997⇒ S/N E108A02263W.....	2.126
SWITCH.....	11.36
TRANSISTOR HYDRAULIC DASH DISPLAY	
PREMIUM TRUCK	
⇒S/N E108A-02263W	2.116

ITEM	PART NO.	DESCRIPTION	QTY
1	Fork (☞ Page 10.8, ☞ Page 10.10)	2
2	Load Backrest Extension (☞ Page 10.2)	1
3	Mast-Two Stage Limited Free-Lift (☞ Page 7.2)	1
3	Mast-Two Stage Full Free-Lift (☞ Page 9.2)	1
3	Three Stage Full Free-Lift (☞ Page 8.2)	1
4	Seat (☞ Page 1.4)	1
5	Overhead Guard (☞ Page 1.22, ☞ Page 1.24, ☞ Page 1.26)	1
6	Accelerator Pedal (☞ Page 1.8)	1
7	Cowl and Floor Plates (☞ Page 1.32, ☞ Page 1.36)	1
8	Counterweight (☞ Page 1.20)	1
9	Trail Axle (☞ Page 4.2)	1
10	Drive Axle (☞ Page 3.2)	1
11	Label (☞ Page 1.12)	AR

ITEM	PART NO.	DESCRIPTION	QTY
1	Accelerator Pedal (Foot Directional Control Pedal) (☞ Page 1.14)	1
2	505966534	Bracket	1
3	505977519	Tube.....	1
4	449001233	Capscrew.....	1
5	449021006	Washer	1
6	449022013	Lockwasher	1
7	449015044	Nut.....	1
8	449001134	Capscrew.....	2
9	505977537	Pedal Stop	2
10	501702904	Adhesive.....	AR
11	504228295	Switch.....	1
12	014862000	Screw.....	4
13	016103200	Washer	4
14	502137903	Lockwasher	4
15	504057758	Electrical Connector	1
16	014936000	Nut.....	4
17	900014292	Capscrew.....	2
18	449022016	Lockwasher	7
19	449021001	Washer	5
20	449015014	Nut.....	8
21	505966556	Plate	1
22	505966574	Throttle Position Sensor	1
23	580010427	Insulator.....	1
24	505974576	Spring.....	1
25	449001052	Capscrew.....	1
26	312850042	Strap Clamp.....	1
27	449001014	Capscrew.....	2
28	505974543	Accelerator Pedal (Forward/Reverse).....	1
29	505974506	Pedal (Forward/Reverse).....	1
30	504228276	Bushing (Forward/Reverse).....	2
31	505974595	Pin (Forward/Reverse)	1
32	504228259	Pad (Forward/Reverse)	1

ITEM	PART NO.	DESCRIPTION	QTY
1	b 504241140	Overhead Guard (Standard Height)	1
1	a 504241144	Overhead Guard (Standard Height)	1
1	a 504241169	Overhead Guard (Raised Height).....	1
1	b 504241171	Overhead Guard (Raised Height).....	1
2	449021010	Washer	10
3	449022017	Lockwasher	10
4	502565907	Capscrew.....	6
5	311321035	Capscrew.....	4
6	504241086	Plate	2
7	505977593	Bar.....	2
8	505977577	Screw.....	2

FOOTNOTES:

- a** 1015 mm Battery Compartment
- b** 847 mm Battery Compartment



LATCH KIT
(OPTIONAL)

ITEM	PART NO.	DESCRIPTION	QTY
	504299752	Hood Latch Kit.....	1
1	504299753	Knob.....	1
2	504299754	Stand Off.....	1
3	504290775	Nylon Block.....	1
4	504290776	Rod.....	1
5	520052897	Spring.....	1
6	720217903	Snap Ring.....	2
7	518790609	Spacer.....	1
8	016337000	Washer.....	1
9	061277800	Washer.....	1
10	015414900	Cotter Pin.....	1
11	518790606	Spring.....	1
12	518803652	Rod End Pin.....	1
13	518790609	Spacer.....	1



ITEM	PART NO.	DESCRIPTION	QTY
1	518803677	Nut.....	1
2	203144700	Capscrew.....	1
3	504241796	Plug.....	2
4	504224284	Cover.....	1
5	504241353	Floorplate.....	1
6	524139122	Cowl.....	1
7	504225227	Washer.....	2
8	449001296	Capscrew.....	2
9	449022017	Lockwasher.....	2
10	449015029	Nut.....	2
11	449001302	Capscrew.....	2
12	449015044	Nut.....	14
13	449022013	Lockwasher.....	14
14	504071785	Washer.....	8
15	502398906	Washer.....	4
16	500092902	Bolt.....	2
17	014936900	Nut.....	2
18	015026400	Lockwasher.....	2
19	504226237	Washer.....	6
20	504261766	Floorplate.....	1
21	504305726	Plate (LH).....	1
21	504305729	Plate (RH).....	1
22	bd 504241280	Fender (LH).....	1
22	cd 504241282	Fender (LH).....	1
22	ad 504241284	Fender (LH).....	1
22	be 504244790	Fender (LH).....	1
22	ce 504244792	Fender (LH).....	1
22	ae 504244794	Fender (RH).....	1
23	bd 504241274	Fender (RH).....	1
23	cd 504241276	Fender (RH).....	1
23	ad 504241278	Fender (RH).....	1
23	be 504244795	Fender (RH).....	1
23	ce 504244797	Fender (RH).....	1
23	ae 504244799	Fender (RH).....	1
24	b 518790635	Cover (Optional).....	1
24	c 518790663	Cover (Optional).....	1
24	a 580000767	Cover (Optional).....	1
25	504275796	Slip Resistant Tread.....	1
26	504244764	Slip Resistant Tread.....	1
27	504265776	Slip Resistant Tread.....	1
28	504265777	Slip Resistant Tread.....	1
29	580023101	Plate.....	1
30	580023103	Plate.....	1
31	580030948	Pin.....	2
32	015914700	Snap Ring.....	2
33	520045578	Capscrew.....	2
34	518790687	Washer.....	2
35	449022013	Lockwasher.....	2
36	449015044	Nut.....	2
37	504231232	Spacer.....	16



**ELECTRICAL SYSTEM
(TRANSISTOR HYDRAULIC)
(⇒S/N E108A-02263W)**

ITEM	PART NO.	DESCRIPTION	QTY
1	502398908	Washer	1
2	504230279	Screw.....	2
3	504230283	Insert	1
4	504230271	Nut.....	1
5	504231255	Horn.....	1
6	518809686	Wire Harness.....	1
7	518793603	Strap.....	1
8	504226242	Washer	1
9	520044849	Hose	1
10	520044901	Power Cable Assembly.....	1
11	449001134	Capscrew.....	1
12	504230211	Insulator.....	1
13	518798642	Terminal Block.....	1
14	d 518798681	Wire Harness (Lights) (☞ Page 2.122)	1
14	e 580001622	Wire Harness (Lights) (☞ Page 2.124)	1
15	504070790	Strap Clamp.....	AR
16	518803683	Tire and Wheel.....	2
17	518793683	Wire Harness.....	1
18	518807623	Washer	2
19	449022022	Lockwasher	2
20	937100902	Nut.....	2
21	058941300	Capscrew.....	1
22	015026400	Lockwasher	2
23	014936900	Nut.....	1
24	504235279	Screw.....	1
25	501702903	Sealant	AR
26	518796664	Battery Connector (72 Volt) (☞ Page 2.90)	1
26	520044806	Battery Connector (72/80 Volt) (☞ Page 2.90)	1
26	518796638	Battery Connector (80 Volt) (☞ Page 2.90)	1
27	504226231	Switch.....	1
28	518793620	Wire Harness (Dash Display) (☞ Page 2.112)	1
28	520044904	Wire Harness (Dash Display) (☞ Page 2.112)	1
28	a 518793607	Wire Harness (Dash Display) (☞ Page 2.114)	1
28	b 520044902	Wire Harness (Dash Display) (☞ Page 2.114)	1
28	c 520048807	Wire Harness (Dash Display) (☞ Page 2.114)	1
28	518798685	Wire Harness (Dash Display) (☞ Page 2.120)	1
29	518793649	Wire Harness (Steering Motor) (☞ Page 2.126)	1
30	504249787	Power Cable Assembly.....	1
31	504249788	Power Cable Assembly.....	1
32	504249789	Power Cable Assembly.....	1
33	504249790	Power Cable Assembly.....	1
34	518793672	Power Cable	1
35	518809674	Power Cable	1
36	520043801	Wire Harness.....	1
37	449001134	Capscrew.....	1
38	518793632	Clamp	1
39	449022016	Lockwasher	1



**CONTROL PANEL
(CONTACTOR HYDRAULIC)
(⇒S/N E108A-02263W)**

ITEM	PART NO.	DESCRIPTION	QTY
1	504235284	Fuse (500 Amp).....	1
2	504226299	Fuse (325 Amp).....	1
3	518796606	Fuse (40 Amp).....	1
4	518790675	Plate	1
5	518797674	Wire Harness.....	1
6	449007040	Screw.....	2
7	940004903	Washer	2
8	502632901	Screw.....	3
9	449001302	Capscrew.....	9
10	449021006	Washer	9
11	449022013	Lockwasher	9
12	449015044	Nut.....	9
13	516809802	Contacteur	1
14	518790604	SCR Controller (☞ Page 2.54)	1
14	518790693	SCR Controller (☞ Page 2.54)	1
15	518790662	Resistor (Field Weakening)	1
16	518790614	Contacteur Panel (☞ Page 2.34)	1
16	518790629	Contacteur Panel (☞ Page 2.36)	1
16	518790658	Contacteur Panel (☞ Page 2.38)	1



**CONTACTOR PANEL
(SCR HYDRAULIC)
(REGENERATIVE BRAKING WITH OR WITHOUT BDI AND LIFT INTERRUPT)
(S/N E108A-02263W⇒)**

ITEM	PART NO.	DESCRIPTION	QTY
	518790629	Contacteur Panel.....	1
1	518798640	Base.....	1
2	505075506	Contacteur (Direction) (☞ Page 2.62).....	1
3	504226241	Contacteur (1A) (☞ Page 2.64).....	1
4	504226276	Contacteur (Regenerative Braking) (☞ Page 2.68).....	1
5	518798683	Bus Bar.....	1
6	518798623	Contacteur (Steering) (☞ Page 2.76).....	1
7	504235270	Varistor.....	1
8	518798614	Diode Block.....	1
9	504227215	Fuse Block.....	1
10	504227228	Shunt.....	1
11	504227211	Diode (No. 7).....	1
12	504227243	Heatsink.....	1
13	518265806	Insulator.....	1
14	518095800	Bushing.....	2
15	503891203	Fuse Block.....	1
16	500903103	Fuse (15 Amp).....	2
17	518798625	Adapter.....	1
18	516923833	Bus Bar.....	2
19	504237285	Fuse.....	1
20	518798604	Bracket.....	1
21	518798637	Insulator.....	1
22	518798697	Insulator.....	1
23	520333808	Spacer.....	2
24	518798679	Bus Bar.....	1
25	518798678	Bus Bar.....	1
26	518798605	Bus Bar.....	1
27	518798694	Bus Bar.....	1
28	518798690	Bus Bar.....	1
29	518798613	Bus Bar.....	1
30	518798632	Bus Bar.....	1
31	518798661	Bus Bar.....	1
32	518803653	Bus Bar.....	1
33	518803608	Insulator.....	1



**CONTACTOR PANEL
(TRANSISTOR HYDRAULIC)
(WITH BDI AND LIFT INTERRUPT AND WITHOUT FIELD WEAKENING)
(⇒S/N E108A-02263W)**

ITEM	PART NO.	DESCRIPTION	QTY
	a 520043847	Contacteur Panel.....	1
	520043850	Contacteur Panel.....	1
1	520043893	Base.....	1
2	505075506	Contacteur (Direction) (☞ Page 2.62)	1
3	505075508	Contacteur (☞ Page 2.72)	1
4	505075507	Contacteur (1A) (☞ Page 2.74)	1
5	a 504226276	Contacteur (☞ Page 2.68)	1
6	a 504235270	Varistor.....	1
7	518798656	Bracket.....	1
8	504227215	Fuse Block.....	1
9	a 504227228	Shunt.....	1
10	a 516913805	Rectifier (No. 3 and 4).....	1
11	a 504227243	Heatsink.....	1
12	a 518265808	Insulation.....	1
13	a 518095800	Bushing.....	1
14	503891203	Fuse Block.....	1
15	500903103	Fuse (15 Amp).....	3
16	520043895	Adapter.....	1
17	516923833	Bus Bar.....	2
18	504237285	Fuse.....	1
19	518798604	Bracket.....	1
20	520043898	Insulator.....	1
21	520053867	Bus Bar.....	1
22	520043818	Bus Bar.....	1
23	520043821	Stud.....	1
24	520043898	Insulator.....	1
25	a 520043899	Insulator.....	1
26	a 520043814	Bus Bar.....	1
27	a 520043815	Bus Bar.....	1
28	a 518798686	Bus Bar.....	1
29	520043820	Stud.....	1

FOOTNOTES:

a Regenerative Braking



CONTACTOR
(FIELD WEAKENING)
(⇒S/N E108A-02263W)

ITEM	PART NO.	DESCRIPTION	QTY
	505075526	Contactors	1
1	516857806	Base	1
2	516856812	Coil	1
3	516865804	Frame	1
4	504223245	Contact (Fixed)	2
5	516862805	Clamp	2
6	516859803	Spring	1
7	516866809	Armature	1
8	519787801	Base	1
9	516861803	Carrier	1
10	519786801	Bushing	1
11	516858805	Contact (Moving)	1
12	512443801	Spring Seat	1
13	516859801	Spring	1
14	516870801	Retainer	1
15	504223220	Shield	2



**CONTACTOR
(STEERING)
(⇒S/N E108A-02263W)**

ITEM	PART NO.	DESCRIPTION	QTY
	518798623	Contacteur	1
1	519739845	Cover	1
2	296320455	Contact (Fixed).....	2
3	296320456	Contact (Moving).....	1
4	518798638	Spring.....	1
5	518798695	Insulator	1
6	518798662	Coil Assembly	1
7	518798656	Bracket	1



INSTRUMENT PANEL
(S/N E108A-02264W⇒)

ITEM	PART NO.	DESCRIPTION	QTY
1	c 524137581	Dash Display (Without Function Keys)	1
1	a 524137582	Dash Display (With Function Keys)	1
1	b 524143126	Dash Display (With Function Keys)	1

FOOTNOTES:

- a** ⇒ S/N E108A-2366
- b** S/N E108A-2367 ⇒
- c** ⇒ D/B 04/2000



**TRACTION MOTOR
(WITH BWI)
(⇒S/N E108A-02263W)**

ITEM	PART NO.	DESCRIPTION	QTY
	a 580001115	Traction Motor.....	1
	b 580002279	Traction Motor.....	1
1	580001517	Snap Ring	1
2	518804609	Ball Bearing (DE)	1
3	518804634	Oil Seal.....	1
4	a 518807685	Bracket (DE).....	1
4	b 580010627	Bracket (DE).....	1
5	518804636	Cover (DE)	1
6	518804646	Armature	1
7	015917400	Snap Ring.....	1
8	518804617	Fan.....	1
9	a 518804697	Snap Ring	1
9	b 501989904	Snap Ring	1
10	a 520040888	Ball Bearing (CE)	1
10	b 519745810	Ball Bearing (CE)	1
11	580001518	Field Coil	1
11	a 520051840	Stud (With Nut)	1
11	b 518804666	Stud (With Nut)	2
11	580001518	Field Coil (Thermostat)	1
12	580001637	Brush Holder Assembly.....	1
13	580001520	Bracket (CE)	1
14	a 520051840	Stud (With Nut)	2
14	b 518804666	Stud (With Nut)	2
15	518802674	Bushing.....	1
16	518806684	Connector	1
17	518806620	Connector	1
18	900010216	Brush Holder.....	1
19	519745812	Spring	8
20	518806636	Connector	1
21	518807655	Connector	1
22	520045399	Brush.....	4
23	518804678	Cover (CE)	1
24	518804649	Cover (CE)	1
	518804654	Cover Screen Kit (With Vented Cover) (Includes Items 5, 23-24).....	1

FOOTNOTES:

- a** ⇒ D/B 02/1998
- b** D/B 02/1998 ⇒



**HYDRAULIC MOTOR
(S/N E108A02268W⇒)**

KEY:

A: Without Brush Wear Indicators

B: With Brush Wear Indicators

ITEM	PART NO.	DESCRIPTION	QTY	
			A	B
	580008562	Hydraulic Motor	1
	580008563	Hydraulic Motor	1	..
1	931701910	Nut.....	4	4
2	520042832	Washer	6	6
3	504057795	Washer	2	2
4	580010748	Field Coil	1	1
5	504057737	Capscrew	12	12
6	580010747	End Head	1	1
7	580010766	Screw	4	4
8	504057745	Washer	14	14
9	580010749	Ball Bearing.....	1	1
10	580011128	Washer	1	1
11	580010750	End Head (Commutator)	1
11	580010771	End Head (Commutator)	1	..
12	580010752	Brush Plate.....	1	1
13	580010773	Brush Spring	8	8
14	580010751	Brush.....	..	4
14	580010772	Brush.....	4	..
15	580010768	Nut.....	2	2
16	932200907	Capscrew	2	2
17	580010774	Ball Bearing.....	1	1
18	932200905	Capscrew	8	8
19	580010756	Armature	1	1
20	580010757	Snap Ring	2	2
21	580010758	Key	1	1
22	580010759	Ring.....	1	1
23	580010760	Cover Band	1	1
24	580010775	Spring.....	1	1
25	580010761	Fan	1	1
26	580010753	Sensor.....	..	1
27	580010754	Spring.....	..	1
28	580010755	Snap Ring	1
29	Housing	1	1



WIRE HARNESS
(TRANSISTOR HYDRAULIC DASH DISPLAY) (PREMIUM TRUCK)
(⇒S/N E108A-02263W)

ITEM	PART NO.	DESCRIPTION	QTY
	580002400	Wire Harness.....	1
1	518793652	Connector (Dash).....	1
2	520043881	Pin.....	6
3	503004206	Plug.....	1
4	503004207	Seal.....	1
5	503004204	Seal.....	9
6	518793647	Connector.....	3
7	503004202	Socket.....	8
8	520038838	Strap Clamp.....	1



WIRE HARNESS
(STEERING MOTOR)
(D/B 11/1997⇒ S/N E108A02263W)

ITEM	PART NO.	DESCRIPTION	QTY
	518793649	Wire Harness.....	1
1	503004201	Plug	1
2	503004205	Plug	1
3	503004203	Seal	2
4	503004202	Socket	9
5	503004204	Seal	3



**WIRE HARNESS
(MAIN)
(S/N E108A-02264W⇒)**

ITEM	PART NO.	DESCRIPTION	QTY
	a 580006866	Wire Harness.....	1
	b 580025512	Wire Harness.....	1
1	520202602	Connector.....	2
2	504064701	Connector.....	3
3	580001849	Secondary Lock	3
4	505968501	Connector.....	4
5	505968535	Secondary Lock	1
6	504064720	Connector.....	1
7	505064754	Secondary Lock	1
8	912906311	Connector.....	1
9	912906332	Seal	1
10	518793670	Connector.....	1
11	518793652	Connector.....	1
12	518806610	Connector.....	1
13	518806687	Secondary Lock	1

FOOTNOTES:

a ⇒ S/N E108A-02503

b S/N E108A-02504 ⇒

**SECTION 3
DRIVE UNIT**

DESCRIPTION	PAGE
DRIVE AXLE	3.2
TRANSMISSION AND DIFFERENTIAL	3.6
WHEEL AND TIRE	
DRIVE	3.10



**WHEEL AND TIRE
(DRIVE)**

KEY:

- A: ERC 20-25 (21 x 7 x 15)**
- B: ERC 30 (21 x 8 x 15)**
- C: ERC 20-25 (21 x 7 x 15 Wide)**
- D: ERC 30 (21 x 7 x 15 Wide)**

ITEM	PART NO.	DESCRIPTION	QTY			
			A	B	C	D
1	a 520038892	Tire and Wheel	2
1	a 520038823	Tire and Wheel	2
1	a 505965548	Tire and Wheel	2	..
1	a 520038874	Tire and Wheel	2
2	518803694	Wheel	2
2	518803689	Wheel	2
2	b 505965584	Wheel	2	..
2	b 518803627	Wheel	2
3	505965501	Tire	2	..	2	..
3	505965516	Tire	2	..	2

FOOTNOTES:

- a** Lug Compound
- b** Wide Only



**STEERING AXLE
(S/N E108A-02427Y⇒)**

ITEM	PART NO.	DESCRIPTION	QTY
1	504227280	Steering Axle	1
2	065267300	Nut	2
3	580011755	Spindle (RH)	1
3	580011756	Spindle (LH)	1
4	504225267	Steering Cylinder Assembly	1
5	a 931017918	Capscrew	4
5	b 311323023	Capscrew	4
6	015918200	Snap Ring	4
7	580052360	Pin	2
8	504224271	Boot	2
9	062159700	Clamp	2
10	502056904	Clamp	2
11	504224219	Tie Rod	2
11	504224264	Bushing	1
12	015418400	Cotter Pin	2
13	022784400	Lube Fitting	2
14	931014904	Capscrew	6
15	504224285	Bearing Cap	2
16	504224222	Shim (0.127 mm)	AR
16	504224232	Shim (0.178 mm)	AR
16	504224292	Shim (0.508 mm)	AR
17	504225236	O-Ring	2
18	065000800	Bearing Set	2
18	065001000	Bearing Cone	1
18	065000900	Bearing Cup	1
19	504224242	Seal	2
20	015139700	Bearing Set (Two On Each Spindle)	4
20	502029903	Bearing Cup	1
20	502029902	Bearing Cone	1
21	015418600	Cotter Pin	2
22	504227283	Hub Cap	2
23	580010477	Nut	2
24	580010476	Washer	2
25	504224217	Wear Sleeve	2
26	504224218	Oil Seal	2
27	909882405	Locknut	4
28	a 504225240	Nut	4
29	a 502566903	Washer (Hardened)	4
30	449021010	Washer	8
31	504224298	Seal	2
32	504224231	Wear Sleeve	2
33	059695400	Bearing Set	2
33	059695500	Bearing Cup	1
33	059695600	Bearing Cone	1
34	504224266	Plug	2
35	504224214	Plate	2

ITEM	PART NO.	DESCRIPTION	QTY
	504226278	Gear Pump	1
1	Housing	1
2	Plug (With On-Demand Steering)	1
3	Screw and Washer	8
4	504226211	Gasket (Amber) (0.0010 mm)	1
5	Pin	2
6	131635419	Needle Bearing	4
7	Woodruff Key	2
8	Gear	3
9	504226234	Shaft	1
10	518696802	Spacer	1
11	Circlip	2
12	Idler Shaft	1
13	518361802	Ball	1
14	518362806	Spring (Small)	1
15	518362802	Spring (Large)	1
16	519249803	Gasket (Copper)	1
17	050107000	Screw	1
18	Nut	1
19	a 504233209	Pressure Switch (Without On-Demand Steering)	1
20	520435802	Cap	1
	504226230	Repair Kit (Includes Items 11, 16)	1

FOOTNOTES:

a ⇒ S/N E108V-10392

CLICK HERE TO **DOWNLOAD** THE COMPLETE MANUAL

- Thank you very much for reading the preview of the manual.
- You can download the complete manual from: www.heydownloads.com by clicking the link below



- Please note: If there is no response to CLICKING the link, please download this PDF first and then click on it.

CLICK HERE TO **DOWNLOAD** THE COMPLETE MANUAL

ITEM	PART NO.	DESCRIPTION	QTY
1	a 518793656	Hose	1
1	b 580000756	Hose	1
2	502056906	Clamp	5
3	518807656	Hose	1
4	013405200	Fitting.....	1
5	c 058888100	Fitting.....	1
6	c 504228231	Fitting.....	1
7	d 019905000	Fitting.....	1
7	c 500179904	Fitting.....	1
8	055485700	Fitting.....	2
8	052645200	O-Ring.....	1
9	504228214	Hose	1
10	062159500	Clamp	2
11	723689100	Fitting.....	1
11	052645400	O-Ring.....	1
12	312850032	Strap Clamp.....	2
13	518796622	Bracket	1
14	504225267	Steering Cylinder Assembly (☞ Page 4.24)	1
15	520045096	Hose (847 mm Battery Compartment)	2
15	518793665	Hose (1015 mm Battery Compartment)	2
16	504226298	Motor (☞ Page 4.30)	1
16	520035803	Steering Motor (☞ Page 4.32)	1
16	580002438	Steering Motor (☞ Page 4.34)	1
16	518803670	Steering Motor (☞ Page 4.40)	1
16	580002437	Steering Motor (☞ Page 4.42)	1
17	504226278	Gear Pump (☞ Page 4.16)	1
17	580000127	Gear Pump (☞ Page 4.20)	1
17	580019605	Gear Pump	1
18	505974525	Plate	2
19	080143400	Mount	3
20	449001050	Capscrew.....	2
21	518796686	Washer	6
22	504226242	Washer	5
23	449022016	Lockwasher	6
24	057780800	Fitting.....	1
24	052645300	O-Ring.....	1
25	449015014	Nut.....	5
26	449001013	Capscrew.....	4
27	504223274	O-Ring	1
28	058941300	Capscrew.....	2
29	015026400	Lockwasher	2
30	518796657	Capscrew.....	1
31	449015044	Nut.....	1
32	449022013	Lockwasher	1
33	504233209	Pressure Switch.....	1
34	520043880	Hose	2
35	502625905	Hose	1
36	b 502600904	Fitting.....	1
37	b 502230904	Fitting.....	1
38	b 580000078	Hose	1



STEERING MOTOR
(WITHOUT BWI)
(S/N E108A02473Y↔S/N E108A02574A)

ITEM	PART NO.	DESCRIPTION	QTY
	580026707	Steering Motor.....	1
1	580026785	Stud.....	2
2	520053826	Nut.....	2
3	580026789	Shield (End)	1
4	504230224	Washer (Spring)	1
5	518804632	Ball Bearing.....	1
6	580026791	Cover.....	1
7	504230281	Gasket.....	1
8	580000138	Screw	2
9	580003376	Brush Holder Assembly.....	1
9	580003167	Brush Holder	1
10	580003166	Terminal	2
11	520053837	Screw	2
12	580027131	Brush	2
13	504230241	Brush Spring	2
14	518804684	Screw (Holder).....	2
15	580027127	Bushing.....	2
16	504230261	Insulator (Insulator)	2
17	504230265	Washer	2
18	015026200	Lockwasher	2
19	504230217	Nut.....	4
20	580026792	Stator.....	1
21	580026793	Armature	1
22	015120100	Ball Bearing.....	1
23	580026794	Shield	1
24	504228246	Oil Seal.....	1
25	580003162	Sleeve	1



STEERING MOTOR
(WITH BWI)
(S/N E108A02575A⇒)

ITEM	PART NO.	DESCRIPTION	QTY
	580035627	Steering Motor (With BWI)	1
1	580003165	Brush Holder	1
2	504230241	Brush Spring	2
3	580003167	Brush Holder	1
4	580027125	Brush	1
5	520053837	Screw	2
6	518804684	Screw	2
7	580027126	Brush	1
8	520053839	Bushing	2
9	580003166	Terminal	2
10	504230281	Gasket	1
11	580000959	Cover	1
12	580000138	Screw	2
13	518804632	Ball Bearing	1
14	504230224	Washer	1
15	580000957	End Shield	1
16	520053826	Nut	2
17	504230217	Nut	4
18	015026200	Lockwasher	2
19	016337000	Washer	2
20	504230261	Insulator	2
21	580000971	Stator	1
22	504575212	Connector	1
23	580003162	Sleeve	2
24	580035789	Armature	1
25	580035782	Retaining Ring	1
26	580000956	Stud	2
27	580009850	Ball Bearing	1
28	580035783	End Shield	1
29	580035784	Oil Seal	1

ITEM	PART NO.	DESCRIPTION	QTY
1	a 505966554	Brake Pedal	1
1	b 520046880	Brake Pedal Assembly	1
2	504224226	Bushing	2
3	449022013	Lockwasher	2
4	518795619	Tube	1
5	502398908	Washer	1
6	449001310	Capscrew	1
7	504225240	Nut	1
8	449001302	Capscrew	1
9	449015044	Nut	3
10	505963537	Master Cylinder (☞ Page 5.12)	1
11	449001015	Capscrew	2
12	505966598	Spring	1
13	580008780	Bolt	1
14	449021006	Washer	4
15	449015098	Locknut	1
16	c 504228253	Washer	4
17	c 518795661	Plate	1
18	c 502137903	Lockwasher	2
19	c 014936000	Nut	2
20	c 014862100	Screw	2
21	504228223	Switch	1
22	e 505972532	Pressure Switch	1
22	f 580046387	Pressure Switch	1
23	c 449021001	Washer	2
24	c 449022016	Lockwasher	2
25	c 519609804	Nut	2
26	505966570	Tube	1
27	c 505966516	Tube	1
27	d 580001623	Tube	1
28	900001201	Pad	1
29	d 502079902	Fitting	1
30	d 013376100	Fitting	1
31	d 580001624	Tube	1
32	c 449001014	Capscrew	2

FOOTNOTES:

- a** ⇒ S/N E108V-4430
- b** S/N E108V-4431 ⇒
- c** ⇒ S/N E108V-7676
- d** S/N E108V-7677 ⇒
- e** ⇒ D/B 09/2002
- f** D/B 09/2002 ⇒

6	HYDRAULIC SYSTEM
---	------------------



**HAND LEVER
(3 FUNCTION - 3 LEVER) (WITHOUT DETENTED LEVERS)
(D/B 10/2001⇒)**

KEY:

A: Three Function (Without Detent Levers)

B: Three Function (With Detent Levers)

C: Four Function (With Detent Levers)

ITEM	PART NO.	DESCRIPTION	QTY		
			A	B	C
1	518791620	Plate	1	1	1
2	505977556	Crank	3	2	3
3	449001412	Capscrew	6	4	6
4	504231270	Nut	6	4	6
5	580027587	Spacer	2	2	2
6	016110000	Washer	2	2	2
7	580030846	Pin Weldment	1	1	1
8	580014200	Support	1	1	1
9	449022018	Lockwasher	1	1	1
10	449021001	Washer	2	2	2
11	504231270	Nut	1	1	1
12	518791696	Link	3	3	4
13	449021006	Washer	8	8	10
14	518791677	Pin	6	6	8
15	015417900	Cotter Pin	6	6	8
16	518805626	Capscrew	2	2
17	449022018	Lockwasher	2	2
18	580014199	Pin (With Raised Hood)	1	1	1
18	580014202	Pin (Without Raised Hood)	1	1	1
19	449001302	Capscrew	2	2	2
20	449022013	Lockwasher	2	2	2
21	449015044	Nut	2	2	2
22	518791600	Spacer	2	2	2
23	449001121	Capscrew	1	1	1
24	518791629	Shim (1,524 mm)	AR	AR	AR
24	518791644	Shim (0,254 mm)	AR	AR	AR
24	518791649	Shim (0,787 mm)	AR	AR	AR
25	505977554	Crank	1	1
26	505977523	Crank	1	1
27	505977520	Bracket (Locking)	1	1
28	449001170	Capscrew	2	2
29	449021003	Washer	4	4
30	449022018	Lockwasher	2	2
31	449015002	Nut	2	2
32	504230239	Spring	1	1
33	504235252	Pin	1	1
34	580027588	Spacer	1	1	..
35	518793604	Boot	1
35	518801664	Boot	1	1	..
36	518791664	Spacer	1
37	504248735	Hand Lever	1	1	1
38	504248736	Hand Lever	1	1	1
39	504248737	Hand Lever	1	..	1
40	504248738	Hand Lever	1	1



**CONTROL VALVE
(FOUR FUNCTION)**

ITEM	PART NO.	DESCRIPTION	QTY
	518791667	Hydraulic Control Valve	1
1	580010503	Tie Rod.....	1
2	505970522	Nut.....	2
3	014936600	Nut.....	4
4	518796675	Tie Rod.....	2
5	061643400	Fitting	1
5	056363300	O-Ring.....	1
6	504230293	Relief Valve	2
6	504232220	Seal and Spring Kit.....	1
7	518796659	Plug.....	1
7	052645400	O-Ring.....	1
8	504230292	Inlet Section	1
9	012823300	O-Ring	1
10	505967593	Plug.....	1
11	052645300	O-Ring.....	1
12	518796605	Spool Section (Lift).....	1
13	502635907	Screw	2
14	504230234	Poppet.....	1
15	504230246	Seal Plate	2
16	504230298	Spring Seat.....	2
17	505967547	Spring	1
18	504230209	Spool End	1
19	504230282	Cap	1
20	504236247	Wiper	2
21	Spool.....	1
22	504234226	Capscrew.....	2
23	504230255	Spring	1
24	012823300	O-Ring	1
25	505967575	O-Ring	2
26	518796654	Spool Section (Tilt).....	1
27	502635907	Screw	2
28	062128400	O-Ring	1
29	504230234	Poppet.....	1
30	504230246	Seal Plate	2
31	504230236	Spring Seat.....	2
32	505967547	Spring	1
33	504230205	Spool End	1
34	504230282	Cap	1
35	504236247	Wiper	2
36	504234226	Capscrew.....	2
37	504230255	Spring	1
38	505967595	Piston.....	1
39	504230207	Spring	1
40	Spool.....	1
41	012823300	O-Ring	1
42	505967575	O-Ring	2
43	518796646	Spool Section (Auxiliary).....	1
44	518796671	Plug.....	1
44	518796688	O-Ring	1
45	502635907	Screw	2



HYDRAULIC PUMP
(12 CC)
(S/N E108V-8570⇒ D/B 04/2000)

ITEM	PART NO.	DESCRIPTION	QTY
	580003863	Hydraulic Pump	1
1	580006358	Cover	1
2	Body	1
3	580006779	Gear Set	1
4	Bushing	2
5	Bushing	2
6	Drive Gear	1
7	Driven Gear	1
8	580006359	Mounting Flange	1
9	Seal (Body)	2
10	Seal (Bushing)	2
11	580006778	Bolt	4
12	Oil Seal	1
13	Circlip	1
14	138583101	Key	1
	580006362	Seal Kit (Includes Items 9-10, 12-13)	1



**INNER MAST
(TWO STAGE LIMITED FREE-LIFT)**

ERC 20-25 AGF

ITEM	DESCRIPTION	OALH				
	Mast Group Number	B507 2992	B507 3292	B507 3792	B507 4292	B507 4792
1	Inner Mast	504072774	504072723	504072786	504074773	504074776

ERC 30 AGF

ITEM	DESCRIPTION	OALH				
	Mast Group Number	B562 2859	B562 3159	B562 3659	B562 4159	B562 4659
1	Inner Mast	504072774	504072723	504072786	504074773	504074776

ITEM	PART NO.	DESCRIPTION	QTY
1	a	Inner Mast	1
2	504066700	Stubshaft	2
3	015916300	Snap Ring	2
4	504233232	Shim (0,508 mm)	AR
5	520036837	Load Roller ("B") (0,76 mm)	2
6	518801662	Pin	2
7	bdf 504064790	Spacer	4
7	ceg 504281792	Spacer	4
8	bdf 504064733	Chain Sheave	2
8	504064727	Sheave	1
8	500343914	Snap Ring	2
8	504242237	Bearing	1
9	ce 504281794	Chain Sheave Assembly (ERC 20-25 AGF)	2
9	504282703	Chain Sheave	1
9	500343914	Snap Ring	1
9	520040899	Bearing	1
10	g 504281793	Chain Sheave Assembly (ERC 30 AGF)	2
10	504282702	Chain Sheave	1
10	500343914	Snap Ring	1
10	520040899	Bearing	1
11	449034021	Pin	2

FOOTNOTES:

- a** Refer to Table
- b** ⇒ S/N B507A-1920
- c** S/N B507A-1921 ⇒
- d** ⇒ S/N B507B-7408
- e** S/N B507B-7409 ⇒
- f** ⇒ S/N B562B-5197
- g** S/N B562B-5198 ⇒



MAIN CYLINDER
(ERC 30 AGF (1981 MM, 2133 MM, 2388 MM)) (TWO STAGE LIMITED FREE-LIFT)
 (⇒D/B 06/2002)

LEFT HAND

ITEM	DESCRIPTION	OALH		
	Mast Group Number	B562 2859	B562 3159	B562 3659
Cylinder Group Number	8600206	8600209	8600214	
	Lift Cylinder	518833606	518833609	518833614
1	Shell	518832606	518832609	518832614
2	Rod	518831606	518831609	518831614

RIGHT HAND

ITEM	DESCRIPTION	OALH		
	Mast Group Number	B562 2859	B562 3159	B562 3659
Cylinder Group Number	8600256	8600259	8600264	
	Lift Cylinder	518833656	518833659	518833664
1	Shell	518832656	518832659	518832664
2	Rod	518831606	518831609	518831614

ITEM	PART NO.	DESCRIPTION	QTY
	a	Lift Cylinder.....	1
1	a	Shell	1
2	a	Rod.....	1
3	518985600	Gland.....	1
4	505657515	Spacer.....	1
5	504147200	Check Valve	1
6	504148200	Washer	1
7	504149200	Shim (0,508 mm).....	AR
7	504150200	Shim (0,178 mm).....	AR
7	504151200	Shim (0,127 mm).....	AR
8	501850904	Snap Ring	1
9	504163200	Wiper Ring	1
10	504160200	Seal	1
11	015492900	O-Ring.....	1
12	504161200	Back-Up Ring	1
13	504024202	Wear Ring	1
14	504155200	O-Ring.....	1
15	502787901	Rod Seal	1
	505136035	Seal Kit (Includes Items 9-15)	1
	505136036	Seal Kit (Includes Items 10-14)	1

FOOTNOTES:

a Refer to Table

8	MAST-THREE STAGE FULL FREE-LIFT
----------	--



INNER MAST
(THREE STAGE FULL FREE-LIFT)
 (⇒S/N B508B-11567, ⇒S/N B563B-6155)

ERC 20-25 AGF

ITEM	DESCRIPTION	OALH			
	Mast Group Number	B508 4310	B508 4910	B508 5510	B508 5960
1	Inner Mast	504062762	504062708	504062769	504062763

ERC 30 AGF

ITEM	DESCRIPTION	OALH				
	Mast Group Number	B563 4118	B563 4718	B563 4868	B563 5318	B563 5918
1	Inner Mast	504062762	504062708	504062750	504062769	504062719

ITEM	PART NO.	DESCRIPTION	QTY
1	a	Inner Mast	1
2	504066700	Stubshaft.....	2
3	015916300	Snap Ring.....	2
4	504233232	Shim (0,508 mm).....	AR
5	580001429	Load Roller	2

FOOTNOTES:

a Refer to Table



**CARRIAGE
(SIX ROLLER) (THREE STAGE FULL FREE-LIFT)**

KEY:

A: ERC 20-25 AGF

B: ERC 30 AGF

ITEM	PART NO.	DESCRIPTION	QTY	
			A	B
	520040873	Carriage Assembly	1	..
	520040892	Carriage Assembly	1
1	520041853	Frame	1	..
1	520041865	Frame	1
2	520036852	Load Roller	6	6
3	015916300	Snap Ring	6	6
4	504233232	Shim (0,508 mm).....	AR	AR
5	504235278	Spacer	2	2
6	505978544	Chain Anchor (Dual Hole)	2	..
6	580027878	Chain Anchor (Single Hole) (Optional)	2	..
6	505978527	Chain Anchor (Dual Hole)	2
	580027880	Chain Anchor (Single Hole) (Optional)	2
7	504071702	Pin	2	2
8	500227907	Snap Ring	4	4
9	580033718	Pin	2	2
10	015415900	Cotter Pin	2	2



**INNER MAST
(TWO STAGE FULL FREE-LIFT)**

ERC 20-25 AGF

ITEM	DESCRIPTION	OALH		
	Mast Group Number	B509 2962	B509 3262	B509 3762
1	Inner Mast	504074703	504074785	504063749

ERC 30 AGF

ITEM	DESCRIPTION	OALH		
	Mast Group Number	B564 2860	B564 3160	B564 3660
1	Inner Mast	504074703	504074785	504063749

ITEM	PART NO.	DESCRIPTION	QTY
1	a	Inner Mast	1
2	504066700	Stubshaft.....	2
3	015916300	Snap Ring.....	2
4	504233232	Shim (0,508 mm).....	AR
5	580001429	Load Roller	2

FOOTNOTES:

a Refer to Table



**MAIN CYLINDER
(LEFT HAND) (TWO STAGE FULL FREE-LIFT)
(S/N B509A-2091Z⇒, S/N B564A-2047Z⇒)**

ITEM	PART NO.	DESCRIPTION	QTY
5	504163200	Wiper Ring	1
6	b 580006341	Gland.....	1
6	c 580049889	Gland.....	1
7	500167920	Back-Up Ring	1
8	015492900	O-Ring.....	1
9	b 504154200	Back-Up Ring	1
10	580022502	Rod Seal	1
11	b 518794659	Wear Ring	1
12	505657539	Spacer (ERC 30 AGF).....	1
13	504017203	Wear Ring	1
14	502895201	Piston Ring.....	1
	580025048	Seal Kit (Includes Items 4-5, 7-11, 13)	1

FOOTNOTES:

- a** Refer to Table
- b** ⇒ D/B 02/2004
- c** D/B 02/2004 ⇒



**CARRIAGE
(SIX ROLLER) (TWO STAGE FULL FREE-LIFT)**

KEY:

A: ERC 20-25 AGF

B: ERC 30 AGF

ITEM	PART NO.	DESCRIPTION	QTY	
			A	B
	518795649	Carriage Assembly	1	..
	518795664	Carriage Assembly	1
1	518795613	Frame	1	..
1	518795654	Frame	1
2	520036816	Load Roller	6	6
3	015916500	Snap Ring	6	6
4	504071779	Shim (0,508 mm).....	AR	AR
5	504072717	Spacer	2	2
6	505978544	Chain Anchor (Dual Hole)	2	..
6	580027878	Chain Anchor (Single Hole) (Optional)	2	..
6	505978527	Chain Anchor (Dual Hole)	2
6	580027880	Chain Anchor (Single Hole) (Optional)	2
7	504071702	Pin	2	2
8	500227907	Snap Ring	4	4
9	580033718	Pin	2	2
10	015415900	Cotter Pin	2	2

KEY:

A: 5° Forward/5° Back

B: 5° Forward/8° Back, 10° Forward/5° Back

ITEM	PART NO.	DESCRIPTION	QTY	
			A	B
1	Tilt Cylinder (☞ Page 6.22)	2	2
2	504229210	Rod End Pin	2
3	015420300	Cotter Pin	4
4	504229225	Bushing	2
5	518790673	Rod End	2
6	311321033	Capscrew.....	..	2
7	449022017	Lockwasher	2
8	937300912	Nut.....	..	2
9	505064777	Pin	2
10	931015917	Capscrew.....	..	4
11	505974573	Rod End Pin	2
12	518803695	Spacer	2	..
13	012828000	O-Ring	2	..
14	505970567	Shim	AR	..
14	505974501	Shim	AR	..

**SECTION 11
OPTIONS**

DESCRIPTION	PAGE
AUXILIARY TUBES	
TWO, THREE AND FOUR STAGE FULL FREE-LIFT	
FOUR FUNCTION GROUP	11.22
BACK-UP ALARM	11.32
BRAKE AND BACK-UP LIGHTS	11.24
DOME LIGHT	11.30
DRIVE AND REAR LIGHTS	11.28
INTEGRAL SIDE-SHIFT CARRIAGE	
THREE STAGE FULL FREE-LIFT	11.16
TWO STAGE FULL FREE-LIFT	11.14
TWO STAGE LIMITED FREE-LIFT	11.12
INTEGRAL SIDE-SHIFT CYLINDER	11.18
INTEGRAL SIDE-SHIFT HYDRAULIC HOSES	
TWO AND THREE STAGE FULL FREE-LIFT	11.21
TWO STAGE LIMITED FREE-LIFT	11.20
SIDE-SHIFT CARRIAGE	
ERC 20-25 AGF	11.2
ERC 30 AGF	11.6
SIDE-SHIFT CYLINDER	11.10
WIRE HARNESS	
LIGHT	
12-VOLT	
D/B 07/1998⇒	11.35
⇒D/B 07/1998	11.34
SWITCH.....	11.36



SIDE-SHIFT CYLINDER

KEY:

A: ERC 20-25 AGF

B: ERC 30 AGF

ITEM	PART NO.	DESCRIPTION	QTY	
			A	B
	519666601	Side-Shift Cylinder.....	1	..
	519668601	Side-Shift Cylinder.....	..	1
1	519665601	Tube	1	..
1	519667601	Shell	1
2	519664601	Rod.....	1	..
2	519664602	Rod.....	..	1
3	504020504	Seal	1	..
3	504020507	Seal	1
4	012825700	O-Ring.....	2	..
5	015492900	O-Ring.....	..	2
6	500167924	Back-Up Ring	2	..
7	502011909	Back-Up Ring	2
8	504234288	Seal	2	2
9	504232210	Wiper Ring	2	2
10	506552501	Gland.....	2	..
10	506552502	Gland.....	..	2
10	501702902	Thread Sealer	AR	AR
	505136053	Seal Kit (Includes Items 4, 6, 8-9)	1	1
	505136054	Seal Kit (Includes Items 5, 7-9)	1	1

INTEGRAL SIDE-SHIFT HYDRAULIC HOSES (TWO AND THREE STAGE FULL FREE-LIFT)

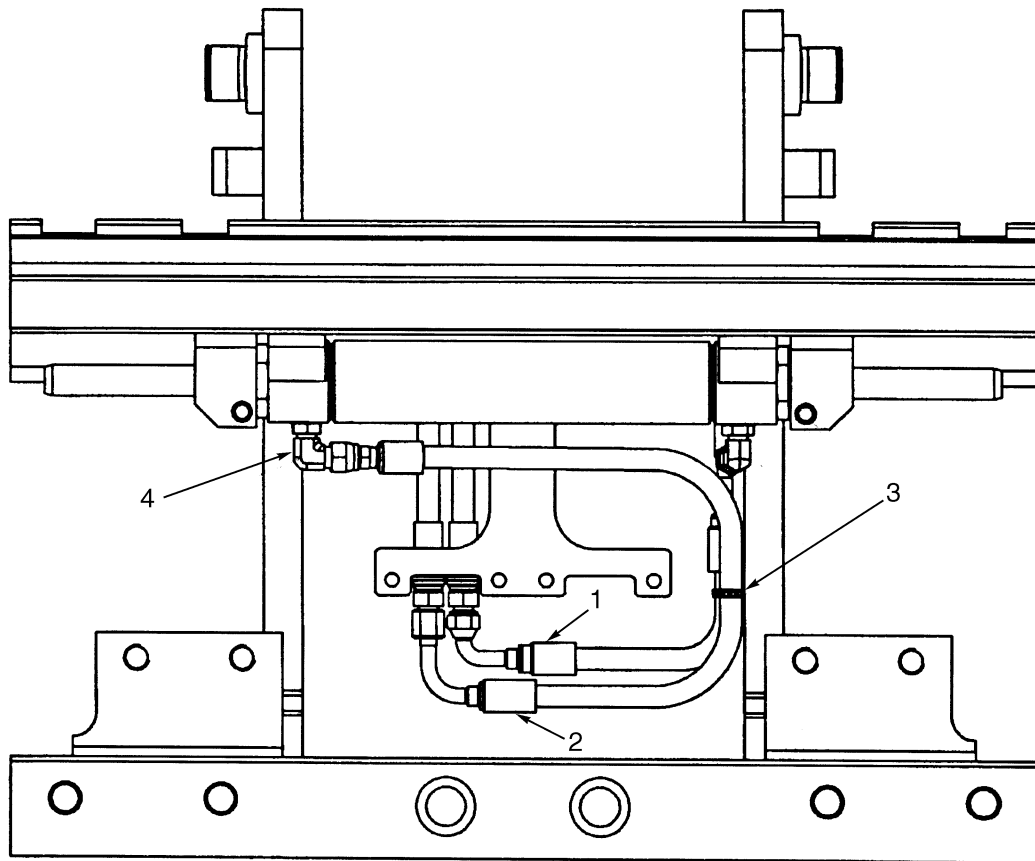

BP000003

KEY:

A: ERC 20-25 AGF (B508, B509)

B: ERC 30 AGF (B563, B564)

ITEM	PART NO.	DESCRIPTION	QTY	
			A	B
1	580027672	Hose (977 mm, 1067 mm, 1219 mm).....	1	..
1	580027673	Hose (977 mm, 1067 mm, 1219 mm).....	..	1
2	580027665	Hose (977 mm, 1067 mm, 1219 mm).....	1	..
2	580027667	Hose (977 mm, 1067 mm, 1219 mm).....	..	1
3	312850042	Strap Clamp.....	1	1
4	052642200	Fitting.....	2	2
4	052645200	O-Ring.....	1	1



DOME LIGHT

ITEM	PART NO.	DESCRIPTION	QTY
1	518796641	Light.....	1
2	518798659	Lens	1
3	518800659	Bulb (72 Volt).....	1
4	504248745	Housing	1
5	518803646	Wire Harness.....	1
6	a 518796610	Switch Assembly	1
6	b 520041894	Switch	1
7	506133502	Bezel.....	1
8	518796616	Clip	2
9	449001014	Capscrew.....	4
10	900003270	Retainer	4
11	900003245	Grommet.....	1

FOOTNOTES:

a ⇒ S/N E108A-1656

b S/N E108A-1657 ⇒



NUMERICAL INDEX

PART NO.	PG.	ITEM	PART NO.	PG.	ITEM	PART NO.	PG.	ITEM	PART NO.	PG.	ITEM
000723873AC3.7		17	014972700	1.29	38	015418200	6.3	15		11.25	28
012823300	4.25	8	015025600	11.25	24		6.5	15		11.25	28
	6.15	9	015026200	4.31	16		6.7	15	016103200	1.13	13
	6.15	24		4.33	16		8.13	9		11.25	28
	6.15	41		4.35	21	015418400	4.3	17	016103300	2.81	16
	6.19	9		4.37	18		4.3	32		11.25	23
	6.19	24		4.39	18		4.7	12	016103500	1.29	11
	6.19	41		4.41	16	015418600	4.7	21		1.37	7
	6.20	70		4.43	21	015420300	10.5	3		6.3	10
012824200	6.23	10		4.45	19		10.7	3		6.5	10
012824300	7.3	3		4.47	18	015492900	7.15	11		6.7	10
	8.3	3	015026400	1.39	7		7.17	9	016103700	1.29	4
	8.5	3		1.41	7		7.19	11	016104000	4.11	24
	9.3	3		1.43	18		8.22	12		5.10	52
012825700	11.11	4		2.5	22		9.13	7	016110000	6.3	6
012827000	6.37	26		2.9	22		9.15	8		6.5	6
012827100	7.11	12		2.17	22		9.17	7		6.7	6
	8.22	11		2.89	13		9.19	8		6.9	6
012828000	10.5	13		4.11	23		11.11	5	016110500	1.29	23
	10.7	13		4.27	29	015493400	6.23	7	016110700	6.41	17
013376100	5.5	30		6.25	9	015493500	8.25	13	016337000	1.33	8
013397900	9.28	22	015027000	1.21	7		9.21	13		4.39	19
013405200	4.27	4	015027700	11.26	32	015627900	3.3	39		4.47	19
014717600	1.21	8		11.26	32	015628700	11.3	12		6.11	32
014862000	1.13	12		11.26	32		11.7	12	019327400	3.3	9
014862100	5.5	20	015035900	6.11	24		11.13	12	019899100	11.23	3
014931500	6.16	56	015120100	4.37	22		11.15	12	019899300	11.23	4
	6.20	56		4.43	25		11.17	12	019905000	4.27	7
014932700	3.3	34		4.45	23	015630100	3.3	33		11.23	5
014936000	1.13	16	015139700	4.3	36	015914700	1.43	32	020376700	3.7	6
	5.5	19		4.3	36	015916300	7.3	8	021197300	11.26	33
	5.9	8		4.7	20		7.5	3		11.26	33
014936200	2.83	17	015414700	5.9	10		8.3	8		11.26	33
	2.85	17		5.9	19		8.5	8	021676700	1.30	51
	11.25	16		6.11	17		8.9	3	022784400	4.3	14
014936500	6.3	11	015414900	1.33	10		8.11	3		4.7	13
	6.5	11	015415900	7.7	4		8.29	3	023081400	6.41	6
	6.7	11		7.21	10		9.3	8	023604600	1.5	16
	6.11	25		8.13	8		9.5	3		1.9	16
014936600	1.29	5		8.18	23	015916500	7.21	3	031898400	2.5	17
	6.15	3		8.29	10		9.25	3		2.9	17
	6.19	3		9.9	23		11.13	14	032643500	1.15	8
014936900	1.39	6		9.25	10		11.15	21		2.83	8
	1.41	6		11.13	21		11.17	21		2.85	8
	1.43	17		11.15	17	015917400	2.93	7		5.7	24
	2.5	23		11.17	17		2.95	1		5.9	34
	2.9	23	015416200	1.29	40		2.95	7		6.11	30
	2.17	23		4.11	15		2.97	7	050107000	4.17	17
014939300	2.14	50		5.7	19	015918200	4.3	22	052229600	9.7	15
	2.22	50		5.9	29		4.7	6	052641400	7.7	22
014970900	2.89	14	015417900	6.9	15	016103100	11.25	28		8.13	25



NUMERICAL INDEX

PART NO.	PG.	ITEM	PART NO.	PG.	ITEM	PART NO.	PG.	ITEM	PART NO.	PG.	ITEM
504574274	4.11	27		7.19	17		5.13			6.19	32
504574275	2.83	1	505136037	8.22	22	505963540	5.13	2		6.20	49
	2.85	1	505136039	7.11	16	505963544	5.13	1		6.20	63
	2.89		505136040	7.12	16	505963564	5.13	13	505967559	7.24	2
504574276	2.89	1	505136041	8.22	21	505963565	5.13	10	505967574	7.24	1
504574277	2.89	2	505136046	8.26	22	505963578	5.3	2	505967575	6.15	25
504575212	4.45	26		9.22	22	505963583	5.13	4		6.15	42
	4.47	22	505136047	8.26	23	505963591	5.3	7		6.16	57
504575298	7.7	17		9.22	23	505964540	5.13	5		6.19	25
	8.13	22	505136048	9.13	12	505964577	5.13	9		6.19	42
	9.7	18	505136051	9.17	13	505964578	5.13	6		6.20	57
504586201	7.11	4	505136053	11.11	11	505964586	5.13	7		6.20	71
504757701	2.83	21	505136054	11.11	12	505964597	5.13	8	505967585	2.85	2
504757702	2.83	21	505318200	4.27	39	505965500	3.3	14		5.7	22
504856200	2.83	13	505587500	8.22	3	505965501	3.11	3	505967593	6.15	10
504955200	1.17	16	505657512	8.22	4	505965509	3.3	38		6.19	10
505064700	2.133	3	505657513	9.13	4	505965513	3.3	35	505967595	6.15	38
505064754	2.133	7		9.17	4		5.3			6.19	38
	2.135	7	505657515	7.15	4	505965516	3.11	3	505967599	7.24	2
	2.137	7	505657517	8.22	4	505965521	6.23		505968501	2.133	4
505064777	10.5	9	505657518	8.22	4	505965535	3.3	35		2.135	4
505075506	2.35	2	505657521	7.11	4		5.3			2.137	4
	2.37	2	505657522	8.22	4	505965539	3.3	7	505968514	2.109	3
	2.39	2	505657539	9.15	12	505965544	3.3	15		2.111	3
	2.41	3		9.19	12	505965548	3.11	1		2.121	3
	2.43	3	505657578	7.17	13	505965550	6.23			2.129	1
	2.45	3	505861501	10.9	1	505965551	3.3	36		2.131	1
	2.47	2	505861502	10.9	1	505965556	3.7	21		11.34	8
	2.49	2	505861503	10.9	1	505965564	3.3	41		11.35	8
	2.63		505861504	10.9	1	505965571	3.3	21		11.37	3
505075507	2.45	4	505862501	10.11	1	505965576	3.3	20	505968533	2.111	1
	2.47	4	505862502	10.11	1	505965580	3.7	13	505968535	2.133	5
	2.49	4	505862503	10.11	1	505965584	3.11	2		2.135	5
	2.75		505862504	10.11	1	505965585	3.3	40		2.137	5
505075508	2.47	3	505890500	1.17	5	505966510	8.17	12	505968536	2.123	6
	2.49	3	505959500	9.28	16	505966516	5.5	27		2.125	6
	2.51	2	505959529	2.91	3	505966534	1.13	2		2.139	5
	2.73			2.91	3	505966546	2.95		505968540	2.111	2
505075517	2.31	22	505959571	8.5	1	505966554	5.5	1	505968541	8.31	1
	2.41	2	505960578	1.25	4	505966556	1.13	21		8.31	3
	2.43	2		1.27	4	505966570	5.5	26	505968552	9.27	5
	2.45	2		10.3	2	505966572	8.17	11	505968554	8.31	1
	2.53	2	505961505	9.28	19	505966574	1.13	22		8.31	3
	2.71		505961568	7.24	7	505966598	5.5	12	505968566	2.123	2
505075526	2.35	5		8.31	12	505967529	7.24	2		2.129	4
	2.41	6	505962533	7.24	6	505967530	7.24	1		2.139	1
	2.49	6		8.31	11	505967541	7.24	1		11.34	5
	2.67		505962578	7.24	17	505967547	6.15	17		11.35	5
505136035	7.15	16	505963500	5.3	1		6.15	32		11.37	4
	7.19	16	505963519	5.13	3		6.16	49	505968568	2.123	1
505136036	7.15	17	505963537	5.5	10		6.19	17		2.125	1



NUMERICAL INDEX

PART NO.	PG.	ITEM	PART NO.	PG.	ITEM	PART NO.	PG.	ITEM	PART NO.	PG.	ITEM
	6.31	1	580007879	2.13	34		3.3	13	580010516	11.3	4
	6.34			2.21	34		6.25	2	580010518	11.3	4
580006359	6.29	8	580007880	2.13	37	580008563	2.107		580010520	11.3	4
	6.31	10		2.21	37		3.3	13	580010525	11.3	3
	6.34		580007881	2.14	38		6.25	2	580010527	11.3	3
580006360	6.34			2.22	38	580008780	5.5	13	580010529	11.3	3
580006361	6.34		580007886	2.13	33	580008806	11.25	8	580010538	11.7	4
580006362	6.29	15		2.21	33		11.35		580010539	11.7	4
	6.31	17	580007887	2.13	34	580008807	11.25	31	580010542	11.7	4
580006776	6.31	3		2.21	34	580008812	11.25	25	580010556	11.7	3
580006777	6.31	13	580007888	2.13	37		11.25	25	580010557	11.7	3
580006778	6.29	11		2.21	37		11.25	25	580010560	11.7	3
580006779	6.29	3	580007889	2.22	38	580008928	11.25	26	580010586	1.7	3
580006831	6.34		580007894	2.13	33	580008939	11.25	12	580010608	2.99	7
580006866	2.13	1		2.21	33	580008947	1.7	7	580010612	2.99	1
	2.21	1	580007895	2.13	34	580008948	1.7	7	580010613	2.99	2
	2.137			2.21	34	580009027	11.25	12	580010614	2.99	3
580007042	11.25	15	580007896	2.13	37	580009288	8.32	32	580010615	2.99	4
580007151	2.13	15		2.21	37		9.28	27	580010616	2.99	5
	2.21	15	580007897	2.14	38	580009289	8.32	33	580010617	2.99	6
	2.141			2.22	38		9.28	28	580010618	2.99	8
580007455	2.29	8	580007899	2.14	38	580009290	8.32	31	580010619	2.99	9
	2.33	8	580007902	2.13	35		9.28	29	580010627	2.97	4
	2.33	25		2.21	35	580009291	8.32	34	580010643	2.93	21
580007456	2.29	9	580007903	2.13	36		9.28	30	580010644	2.93	4
	2.33	9		2.21	36	580009299	2.99		580010645	2.93	12
	2.33	31	580007904	2.13	35	580009850	4.39	26	580010679	1.7	8
580007602	4.35	14		2.21	35		4.47	27	580010728	1.15	4
580007603	4.31	9	580007905	2.13	36	580010327	1.5	3	580010747	2.107	6
	4.33	10	580007906	2.13	35		1.7	16	580010748	2.107	4
	4.35	16		2.21	35	580010427	1.13	23	580010749	2.107	9
	4.41	9	580007907	2.13	36	580010428	1.15	5	580010750	2.107	11
	4.43	17		2.21	36	580010432	1.15	6	580010751	2.107	14
580007775	2.29	23	580007931	2.29	2	580010433	1.15	11	580010752	2.107	12
580007776	2.33	23		2.29	22	580010434	1.15	14	580010753	2.107	26
580007777	2.33	24		2.33	2	580010467	1.7	5	580010754	2.107	27
580007778	2.29	24		2.51		580010468	1.7	6	580010755	2.107	28
580007781	2.53		580007933	2.13	20	580010469	1.7	9	580010756	2.107	19
580007804	2.29	7		2.21	20	580010474	4.49	2	580010757	2.107	20
	2.33	7		2.91	1	580010475	4.3	15	580010758	2.107	21
580007805	2.21	36	580007936	2.13	20	580010476	4.4	39	580010759	2.107	22
580007806	2.29	1		2.21	20		4.7	24	580010760	2.107	23
	2.29	1		2.91	1	580010477	4.3	34	580010761	2.107	25
	2.33	1	580007937	2.13	20		4.7	23	580010766	2.107	7
580007808	2.33	22		2.21	20	580010503	6.19	1	580010768	2.107	15
580007838	2.14	44		2.91	1	580010507	11.3	22	580010771	2.107	11
	2.22	44	580008424	1.5			11.7	22	580010772	2.107	14
580007840	2.14	45	580008560	2.13	26	580010509	11.3	22	580010773	2.107	13
	2.22	45		2.21	26		11.7	22	580010774	2.107	17
580007878	2.13	33		2.139		580010512	11.4	22	580010775	2.107	24
	2.21	33	580008562	2.107			11.8	22	580010912	7.8	29

CLICK HERE TO **DOWNLOAD** THE COMPLETE MANUAL

- Thank you very much for reading the preview of the manual.
- You can download the complete manual from: www.heydownloads.com by clicking the link below



- Please note: If there is no response to CLICKING the link, please download this PDF first and then click on it.

CLICK HERE TO **DOWNLOAD** THE COMPLETE MANUAL