

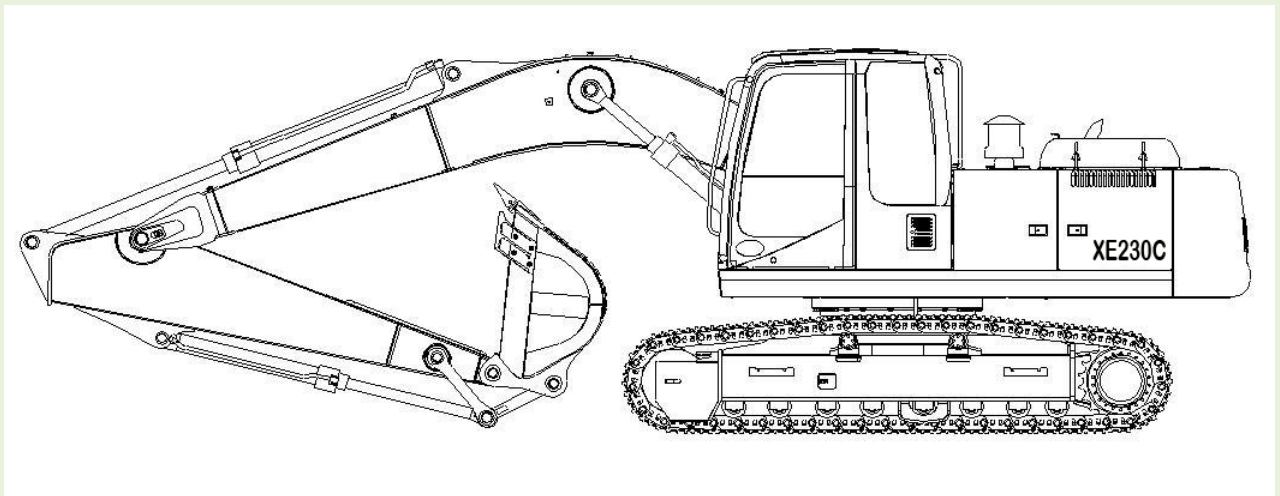

XE230 液压挖掘机
HYDRAULIC EXCAVATOR

零件手册
PARTS CATALOG



徐州徐工挖掘机械有限公司

XUZHOU XUGONG EXCAVATOR MACHINERY CO.,LTD

CLICK HERE TO **DOWNLOAD** THE COMPLETE MANUAL

- Thank you very much for reading the preview of the manual.
- You can download the complete manual from: www.heydownloads.com by clicking the link below



- Please note: If there is no response to CLICKING the link, please download this PDF first and then click on it.

CLICK HERE TO **DOWNLOAD** THE COMPLETE MANUAL

回转平台总成 Frame

序号 ITEM	零件代号 Part No	零件名	PART NAME	数量 Q'TY	服务 代码 S.C	适用机号 SERIAL NO	互 换 性 IA	替换零件 REPLACEABLE PART	
								零件代号 Part No	数量 Q'TY
1	801905432	胶条	Rubber	2					
2	310600419	护套	Rubber	2					
3	801906593	胶条	Rubber	1					
4	801905459	胶条	Rubber	1					
5	801907787	胶条	Rubber	1					
6	310800375	胶条	Rubber	3					
7	310600420	护套	Rubber	1					
8	310800374	护套	Rubber	3					
9	310600419	护套	Rubber	2					
10	310600630	护套	Rubber	2					
11	310800373	胶条	Rubber	2					
12	310600416	护套	Rubber	1					
13	805000714	螺栓 M10×20	Bolt	2					
14	805300014	垫圈 10	Washer	2					
15	310600414	盖板	Cover	1					
16	310600415	密封垫	Rubber	1					

扶手 Stay

序号 ITEM	零件代号 Part No	零件名	PART NAME	数量 Q'T Y	服务 代码 S.C	适用机号 SERIAL NO	互 换 性 IA	替换零件 REPLACEABLE PART	
								零件代号 Part No	数量 Q' TY
1	805000013	螺栓 M16×35	Bolt	6					
2	860105376	垫圈 16	Washer	6					
3	310600145	扶手组件	Stay	1					
4	310600146	后视镜支架	Bracket	1					
5	801905474	外后视镜	Mirror	1					
6	3106013318	连接块	Clamp	1					
7	05103584	螺钉 M8×16	Screw	2					

机棚总成 Protector

序号 ITEM	零件代号 Part No	零件名	PART NAME	数量 Q'T Y	服务 代码 S.C	适用机号 SERIAL NO	互 换 性 IA	替换零件 REPLACEABLE PART	
								零件代号 Part No	数量 Q' TY
1	805300102	垫圈 10	Washer	15					
2	805000714	螺栓 M10×20	Bolt	13					
3	805000727	螺栓 M10×25	Bolt	2					
4	310800140	左后封板	Cover	1					
5	310800159	左后盖板	Cover	1					
6	310800133	左前盖板	Cover	1					

驾驶室总成 Cab Assy

序号 ITEM	零件代号 Part No	零件名	PART NAME	数量 Q'T Y	服务 代码 S.C	适用机号 SERIAL NO	互 换 性 IA	替换零件 REPLACEABLE PART	
								零件代号 Part No	数量 Q' TY
								1	310600074
2	801906314	橡胶垫板	Rubber Mat	1					
3	310600084	护套(三)	Rubber Guard	1					
4	310600083	护套(二)	Rubber Guard	1					
5	310600082	护套(一)	Rubber Guard	1					

发动机系统 Engine System

序号 ITEM	零件代号 Part No	零件名	PART NAME	数量 Q'T Y	服务 代码 S.C	适用机号 SERIAL NO	互 换 性 IA	替换零件 REPLACEABLE	
								PART	
								零件代号 Part No	数量 Q' TY
1	805004707	螺栓 M16×150	Bolt	2					
2	805302498	垫圈 16	Washer	4					
3	310801640	支架总成	Bracket	1					
4	800104934	发动机减震器	Rubber Cushion	4					
5	310801651	垫板	Washer	2					
6	805203179	螺母 M16	Nut	2					
7	800104272	发动机	Engine	1					
8	805000596	螺栓 M18×55	Bolt	2					
9	310800508	垫圈	Washer	2					
10	800104933	发动机减震器	Rubber Cushion	2					
11	805300011	垫圈 16	Washer	4					
12	805300013	垫圈 16	Washer	4					
13	805200051	螺母 M16	Nut	4					
14	800104538	机油滤清器	Oil Filter	1	Z				
14-1	819909162	机油滤芯	Oil Filter Core	1	Z				
15	805000674	螺栓 M10×110	Bolt	2					
16	310800509	螺栓	Bolt	2					
17	805300017	垫圈 10	Washer	9					
18	803110273	弯头	Tie-in	4					
19	803171967	软管总成	Hose ASM	2					
20	805300014	垫圈 10	Washer	9					
21	805100520	螺钉 M20×55	Bolt	4					
22	805000604	螺栓 M10×30	Bolt	9					
23	310800507	油泵接盘	Plate	1					
24	801905672	单偏式带胶套卡箍	Clamp	1					
25	805300069	垫圈 8	Washer	1					
26	805300010	垫圈 8	Washer	1					
27	805000017	螺栓 M8×25	Bolt	1					
28	800104326	发动机停车阀总成	Stopper ASM.	1					
29	800104500	联轴器	Rotating Joint	1					
30	310802038	支架总成	Bracket	1					
31	805302497	垫圈 10	Washer	16					
32	805006196	螺栓 M10×1.25×25	Bolt	7					
33	805200048	螺母 M10	Nut	1					

发动机系统 Engine System

序号 ITEM	零件代号 Part No	零件名	PART NAME	数量 Q'T Y	服务 代码 S.C	适用机号 SERIAL NO	互 换 性 IA	替换零件 REPLACEABLE PART	
								零件代号 Part No	数量 Q' TY
1	310800187	拉杆	Left Bracket	1					
2	805000013	螺栓 M16×35	Bolt	2					
3	805300011	垫圈 16	Washer	2					
4	805300013	垫圈 16	Washer	2					
5	800104931	发动机进水管	Water Hose	1					
6	800104560	喉箍	Clamp	4					
7	800104936	发动机进水管	Water Hose	1					
8	310800480	橡胶圈	Rubber ring	1					
9	805200053	螺母 M6	Nut	2					
10	805004679	螺栓 M6×70	Bolt	2					
11	310800479	卡箍	Clamp	2					
12	805300020	垫圈 12	Washer	4					
13	805300018	垫圈 12	Washer	4					
14	805000048	螺栓 M12×35	Bolt	4					

发动机 Engine

序号 ITEM	零件代号 Part No	零件名	PART NAME	数量 Q'T Y	服务 代码 S.C	适用机号 SERIAL NO	互 换 性 IA	替换零件 REPLACEABLE PART	
								零件代号 Part No	数量 Q' TY
59	800105004	曲轴前油封	Seal; Oil Crankshaft Ft	1					
60	800105005	曲轴后油封	Seal; Oil Crankshaft Rr	1					
61	800104525	喷油泵	Inj Pump Asm	1					
62	800104417	喷油器	Nozzle Asm; Inj	1					
63	800104418	喷油嘴	Nozzle; Inj	1					
64	800104400	手油泵	Pump Asm; Fuel Feed, Inj Pump	1					
65	800104415	起动电机	Starter	1					
66	800104416	交流发电机	Generator	1					
67	819910494	电压调节器	Regulator Asm; Voltage, Gen	1					
68	800104419	涡轮增压器	Turbocharger	1					
69	800104411	曲轴	Crankshaft	1					
70	800104413	节温器	Thermostat	1					
71	800104414	水泵	Pump Asm; Water	1					
72	801905469	(发动机) 前减振 垫	Cushion Bubber; Eng Mtg, Front	1					
73	801905603	(发动机) 后减振 垫	Cushion Bubber; Eng Myg, Rear	1					

上车液压管路 Upper Hydraulic Piping

序号 ITEM	零件代号 Part No	零件名	PART NAME	数量 Q'T Y	服务 代码 S.C	适用机号 SERIAL NO	互 换 性 IA	替换零件 REPLACEABLE PART	
								零件代号	数量
								Part No	Q' TY
1	310600558	安装座	Seat	1					
2	805300018	垫圈 12	Washer	15					
3	805000716	螺栓 M12×30	Bolt	2					
4	310601498	钢管总成 II (黄色)	Pipe	1					
5	803172180	接头	Coupling	1					
6	310600961	管夹	Clamp	1					
7	805000041	螺栓 M12×70	Bolt	1					
8	803166449	堵头	Plug	1					
9	803172074	软管总成	Hose Assembly	1					
10	803172189	堵头	Plug	1					
11	805000264	螺栓 M12×90	Bolt	8					
12	310801636	钢管总成 I (黄色)	Pipe	1					
13	801100325	O 形圈 73×3.55	O-ring	4					
14	310800462	法兰	Flange	2					
15	803172063	单向阀	Valve	1					
16	310800461	回油块	Block	1					
17	805000403	螺栓 M12×110	Bolt	4					
18	803172064	单向阀	Valve	1					
19	310800198	钢管总成 III (黄色)	Pipe	1					
20	801905604	卡箍 Φ54-62	Clamp	4					
21	803172315	耐油胶管 Φ42×58-200	Hose	1					

上车液压管路 Upper Hydraulic Piping

序号 ITEM	零件代号 Part No	零件名	PART NAME	数量 Q'T Y	服务 代码 S.C	适用机号 SERIAL NO	互 换 性 IA	替换零件 REPLACEABLE PART	
								零件代号	数量
								Part No	Q' TY
1	803164234	法兰组件	Flange	4					
2	805103652	螺钉 M10×35	Bolt	16					
3	819908667	软管总成	Hose Assembly	1					
4	819908668	软管总成	Hose Assembly	1					
5	803172215	软管总成	Hose Assembly	1					
6	803172128	软管总成	Hose Assembly	1					
7	803166504	接头	Adapter	4					

回转马达 Swing Motor

序号 ITEM	零件代号 Part No	零件名	PART NAME	数量 Q'T Y	服务 代码 S.C	适用机号 SERIAL NO	互 换 性 IA	替换零件 REPLACEABLE PART	
								零件代号 Part No	数量 Q' TY
100	860120565	壳体	Casing	1					
151	860120566	油塞	Plug	2					
161	860120567	O 型圈	O-Ring	2					
162	860120568	O 型圈	O-Ring	2					
163	860120569	O 型圈	O-Ring	2					
171	860120570	内六角螺栓	Screw	4					
400	860120571	防逆转阀	Anti-Reaction Valve	2					
400-1	860120572	O 型圈	O-Ring	2					
400-2	860120573	挡圈	Ring, Back-Up	2					

主阀 Main Valve

序号 ITEM	零件代号 Part No	零件名	PART NAME	数量 Q'T Y	服务 代码 S.C	适用机号 SERIAL NO	互 换 性 IA	替换零件 REPLACEABLE PART	
								零件代号 Part No	数量 Q' TY
154	860120695	ROH 堵头	Casing	7					
163	860120696	O 型圈	O-Ring	1					
169	860120697	O 型圈	O-Ring	4					
201	860120698	弹簧盖	O-Ring	4					
202	860120699	滑阀盖	O-Ring	4					
203	860120700	弹簧盖	Spring Cover	4					
204	860120701	滑阀盖	Slide Valve Cover	4					
207	860120702	弹簧盖	Spring Cover	2					
252	860120703	逻辑阀组件	Logic Valve Kit	2					
261	860120704	O 型圈	O-Ring	7					
264	860120705	O 型圈	O-Ring	5					
273	860120706	内六角螺栓	Bolt	40					
302	860120707	斗杆滑阀组件	Slide Valve Assy,Arm	1					
305	860120708	回转滑阀组件	Slide Valve Assy,Slew	1					
307	860120709	大臂滑阀组件	Slide Valve Assy, Boom	1					
310	860120710	行走阀阀芯组件	Spool Kit,Travel Valve	1					
392	860120711	旁路切断阀阀芯 组件	By-Pass Cut-Off Assy	1					
395	860120712	回转优先阀阀芯 组件	Slew Priority Spool,Assy	1					
551	860120713	ROMH 堵头	Plug	13					
561	860120714	O 型圈	O-Ring	18					

CLICK HERE TO **DOWNLOAD** THE COMPLETE MANUAL

- Thank you very much for reading the preview of the manual.
- You can download the complete manual from: www.heydownloads.com by clicking the link below



- Please note: If there is no response to CLICKING the link, please download this PDF first and then click on it.

CLICK HERE TO **DOWNLOAD** THE COMPLETE MANUAL

先导液压管路 Pilot Hydraulic Piping

序号 ITEM	零件代号 Part No	零件名	PART NAME	数量 Q'T Y	服务 代码 S.C	适用机号 SERIAL NO	互 换 性 IA	替换零件 REPLACEABLE PART	
								零件代号 Part No	数量 Q' TY
1	803172161	接头	Adapter	4					
2	803163606	测试接头	Test Adapter	2					
3	803166479	接头	Tee	2					
4	803172247	软管总成	Hose Assembly	1					
5	803172183	软管总成	Hose Assembly	1					
6	803163572	接头	Elbow	2					

先导液压管路 Pilot Hydraulic Piping

序号 ITEM	零件代号 Part No	零件名	PART NAME	数量 Q'T Y	服务 代码 S.C	适用机号 SERIAL NO	互 换 性 IA	替换零件 REPLACEABLE PART	
								零件代号	数量
								Part No	Q' TY
1	803172161	接头	Adapter	4					
2	803182803	软管总成	Hose Assembly	1					
3	310600434	压板	Plate	4					
4	803182803	软管总成	Hose Assembly	1					
5	805000714	螺栓 M10×20	Bolt	4					
6	805300014	垫圈 10	Washer	4					
7	310600437	底板总成	Plate Assembly	1					
8	803172160	接头	Adapter	4					
9	803173403	软管总成	Hose Assembly	1					
10	803173403	软管总成	Hose Assembly	1					
11	803163572	弯头	Elbow	4					
12	805000727	螺栓 M10×25	Bolt	4					
13	805300014	垫圈 10	Washer	4					
14	310600435	支块	Block	4					

左先导阀 Left Pilot Valve

序号 ITEM	零件代号 Part No	零件名	PART NAME	数量 Q'T Y	服务 代码 S.C	适用机号 SERIAL NO	互 换 性 IA	替换零件 REPLACEABLE PART	
								零件代号 Part No	数量 Q' TY
101	860120174	护套	Casing	1	D				
111	860120175	盘	Plate	1					
121	860120176	密封垫圈	Seal Washer	2					
122	860120177	O形圈	O-Ring	1					
125	860120178	螺栓	Bolt	2					
126	860120179	弹簧销	Spring Pin	1					
131	860120180	衬套	Bush	1					
151	860120181	盘	Plate	1					
201	860120182	阀芯	Spool	4	D				
211	860120183	堵头	Plug	4	D				
212	860120184	推杆	Push Rod	4					
213	860120185	密封圈	Seal	4					
214	860120186	O形圈	O-Ring	4	D				
216	860120187	弹簧座	Spring Seat	4					
217	860120188	垫圈	Washer	4					
221	860120189	弹簧	Spring	4					
241	860120190	弹簧	Spring	4					
301	860120191	连接件	Joint	1					
302	860120192	盘	Plate	1					
312	860120193	螺母	Nut	1					
501	860120198	防尘罩	Bellows	1					
601	803007152	手柄总成 (左)	Handle Sub Assy (Lh)	1					

电气系统 Electric System

序号 ITEM	零件代号 Part No	零件名	PART NAME	数量 Q'TY	服务 代码 S.C	适用机号 SERIAL NO	互 换 性 IA	替换零件 REPLACEABLE	
								PART	
								零件代号 Part No	数量 Q' TY
1	805100271	螺钉 M4×16	Screw	4					
2	805300027	垫圈 4	Washer	4					
3	805300157	垫圈 4	Washer	4					
4	803608734	保险丝 5A	Fuse	6					
5	803608735	保险丝 10A	Fuse	10					
6	803608737	保险丝 20A	Fuse	4					
7	803608738	保险丝 30A	Fuse	1					
8	803704537	保险丝盒	Fuse box	1					
9	310601351	箱体总成	Case	1					
10	803608687	熄火继电器	Flameout relay	1					
11	805300030	垫圈 6	Washer	7					
12	805302506	垫圈 6	Washer	7					
13	805103605	螺钉 M6×16	Screw	7					
14	803608775	继电器	Relay	7					
15	803608688	预热继电器	Preheat relay	1					
16	803608842	继电器	Relay	1					
17	805300109	垫圈 5	Washer	12					
18	805300119	垫圈 5	Washer	12					
19	805100275	螺钉 M5×16	Screw	8					
20	803604774	一路保险丝盒	Fuse box	2		D10/12-		803608769	2
21	803602240	保险丝	Fuse	2					
22	803504604	预热控制器	Preheat controller	1					
23	805300017	垫圈 10	Washer	4					
24	805300014	垫圈 10	Washer	4					
25	805000727	螺栓 M10×25	Bolt	4					
26	803608697	电源继电器	Main relay	1					
27	803704524	快速螺钉	Screw	4					
28	803704526	夹紧型搭扣	Tower buckle	4					
29	803704525	中型挡圈	Medium-ring	4					
30	310601350	箱盖	Box Cover	1					
31	805000237	螺栓 M8×45	Bolt	4					
32	805300010	垫圈 8	Washer	6					
33	805300069	垫圈 8	Washer	6					
34	803504598	主控制器	Main Controller	1					
35	805000033	螺栓 M8×16	Bolt	2					
36	819908628	单偏式卡箍	Clamp	2					
37	803608689	起动继电器	Start Relay	1					
38	310802046	电气控制箱线束	Harness	1		D10/12-		310800179	1
39	803608710	电源继电器与起动机 连线	Cable	1					

电气系统 Electric System

序号 ITEM	零件代号 Part No	零件名	PART NAME	数量 Q'T Y	服务 代码 S.C	适用机号 SERIAL NO	互 换 性 IA	替换零件 REPLACEABLE PART	
								零件代号 Part No	数量 Q' TY
								1	805100273
2	805300119	垫圈 5	Washer	5					
3	805300109	垫圈 5	Washer	5					
4	803504597	油位传感器	Fuel Level Sensor	1					

空调系统 1 Air Conditioner System 1

序号 ITEM	零件代号 Part No	零件名	PART NAME	数量 Q'T Y	服务 代码 S.C	适用机号 SERIAL NO	互 换 性 IA	替换零件 REPLACEABLE PART	
								零件代号	数量
								Part No	Q' TY
1	310800073	压缩机支架	Bracket	1					
2	805300017	垫圈 10	Washer	5					
3	805300014	垫圈 10	Washer	5					
4	805004785	螺栓 M10×1.25×25	Bolt	2					
5	800309027	B 槽涨紧轮	Wheel	1					
6	805004784	螺栓 M10×1.25×110	Bolt	2					
7	819908682	螺栓 M10×1.25×30	Bolt	1					
8	805002815	螺栓 M8×90	Bolt	4					
9	805300010	垫圈 8	Washer	4					
10	805300069	垫圈 8	Washer	4					
11	819909396	压缩机	Compressor	1					
12	819908679	汽车 V 带	Strap	1					

空调系统 2 Air Conditioner System 2

序号 ITEM	零件代号 Part No	零件名	PART NAME	数量 Q'TY	服务 代码 S.C	适用机号 SERIAL NO	互 换 性 IA	替换零件 REPLACEABLE PART	
								零件代号 Part No	数量 Q' TY
1	805004695	螺栓 M10×1.25×20	Bolt	2					
2	805300014	垫圈 10	Washer	4					
3	805300017	垫圈 10	Washer	4					
4	803506167	压缩机支架 II	Bracket	1					
5	805004753	螺栓 M10X1.25X60	Bolt	2					
6	310601884	调整垫片	Washer	1					
7	805300014	垫圈 14	Washer	1					
8	310800073	螺栓 M14X40	Bolt	3					
9	805200049	螺母 M12	Nut	1					
10	805000149	螺栓 M12X100	Bolt	1					
11	805300029	垫圈 6	Washer	2					
12	805000126	螺栓 M6X30	Bolt	2					
13	805300069	垫圈 8	Washer	4					
14	805000395	螺栓 M8X70	Bolt	4					
15	803506186	压缩机	Compressor	1					
16	800306908	皮带	Strap	1					
17	310601888	压缩机支架 I	Bracket	1					

800305429 履带 Track Chain

序号 ITEM	零件代号 Part No	零件名	PART NAME	数量 Q'T Y	服务 代码 S.C	适用机号 SERIAL NO	互 换 性 IA	替换零件 REPLACEABLE PART	
								零件代号	数量
								Part No	Q' TY
1	800340289	左主链轨节	Master Link LH	2					
2	800340288	右主链轨节	Master Link RH	2					
3	819908998	主销轴	Master Track Pin	2					
4	800340292	主销套	Master Bushing	2					
5	800340293	主密封圈	Master Spacer	4					
6	800340296	开口销	Cotter Pin	2					
7	800309047	螺母	Track Nut	376					
8	800340295	左链轨节	Track Link LH	92					
9	800340294	右链轨节	Track Link RH	92					
10	800340290	销套	Bushing	92					
11	800340291	密封圈	Spacer	184					
12	819908997	销轴	Track Pin	92					
13	819908994	履带板	Track Shoe	94					
14	800340255	螺栓	Track Bolt	376					
	819908996	链轨合件	Track Link	94					

行走马达 Travel Motor

序号 ITEM	零件代号 Part No	零件名	PART NAME	数量 Q'TY	服务 代码 S.C	适用机号 SERIAL NO	互 换 性 IA	替换零件 REPLACEABLE	
								PART	
								零件代号 Part No	数量 Q' TY
1-8	860120770	滚球轴承	Ball Bearing	1					
1-9	860120771	滚球轴承	Ball Bearing	1					
1-10	860120772	销	Pin	1					
1-11	860120773	螺栓 M14×35L	Bolt	10					
1-12	860120774	密封油	Sealing Oil	1					
1-13	860120775	多片盘闸	Multi-Plate Disc Brake	3					
1-14	860120776	摩擦片	Friction Disk	2					
1-15	860120777	活塞	Piston	1					
1-16	860120778	D 型环	D-Ring	1					
1-17	860120779	D 型环	D-Ring	1					
1-18	860120780	弹簧	Spring	8					
1-19	860120781	销	Pin	4					
1-20	860120782	弹簧	Spring	2					
1-21	860120783	配流盘	Valve Plate	1					
1-22	860120784	O 形圈	O-Ring	4					
1-23	860120785	O 形圈	O-Ring	1					
1-25	860120786	螺杆传动 1.85×4.8L	Screw Drive	2					
1-26	860120787	运输用塞 PT 1	Shipping Plug	2					
1-27	860120788	运输用塞 PT 1/2	Shipping Plug	1					
1-28	860120789	运输用塞 PT 1/4	Shipping Plug	1					
3	860120790	斜角滚珠轴承	Angular Ball Bearing	2					
5	860120791	垫片 T=0.05	Washer	1					
5	860120792	垫片 T=0.1	Washer	1					
5	860120793	垫片 T=0.3	Washer	1					
5	860120794	垫片 T=0.5	Washer	1					
5	860120795	垫片 T=1.0	Washer	1					
6	860120796	轴 C	Shaft	1					
7	860120797	垫圈	Washer	8					
8	860120798	螺栓	Bolt	8					
9	860120799	止推板	Thrust Plate	4					
10	860120800	轴承内圈	Bearing Inner Race	4					
11	860120801	轴承滚针	Bearing Needle	4					
12	860120802	行星齿轮 C	Planet Gear	4					
13	860120803	止推板	Thrust Plate	4					
14	860120804	螺栓	Bolt	4					
15	860120805	太阳轮 C	Sun Gear	1					

310800110 工作装置 Worker

序号 ITEM	零件代号 Part No	零件名	PART NAME	数量 Q'TY	服务 代码 S.C	适用机号 SERIAL NO	互 换 性 IA	替换零件 REPLACEABLE	
								PART	
								零件代号 Part No	数量 Q' TY
1-1	801102851	调整垫	Spacer	2					
1-2	801102844	调整垫	Spacer	1					
1-3	819910617	调整垫	Spacer	2					
2	803172463	防尘圈	Dustproof Seal	4					
3	800514230	轴承	Bushing	2					
4	310800275	动臂	Boom	1					
5	310800112	轴	Pin	1					
6	310600280	滑动套	Bushing	2					
7	310600281	垫圈	Plate	2					
8	805300011	垫圈 16	Washer	2					
9	801902674	螺栓 M16×35 (10.9)	Bolt	2					
10	310800111	轴	Pin	2					
11	310700019	压板	Spacer	2					
12	805300018	垫圈 12	Washer	4					
13	805000719	螺栓 M12×25 (10.9)	Bolt	4					
14	803007284	左动臂油缸	Left Boom Cylinder	1					
15	803007283	右动臂油缸	Right Boom Cylinder	1					
16	805200052	螺母 M20	Nut	4					
17	310600275	止动环	Stopper	2					
18	805001955	螺栓 M20×160 (10.9)	Bolt	2					
19-1	819908701	调整垫	Spacer	2					
19-2	819908702	调整垫	Spacer	2					
20-1	801102847	调整垫	Spacer	8					
20-2	801102848	调整垫	Spacer	8					
21	310800335	轴	Pin	1					
22	310800333	轴	Pin	1					
23	805001956	螺栓 M20×180 (10.9)	Bolt	1					
24	803007285	斗杆油缸	Arm Cylinder	1					
25	310800321	轴	Pin	1					
26-1	801102849	调整垫	Spacer	1					
26-2	801102850	调整垫	Spacer	2					

动臂油缸（左） Boom Cylinder（L）

序号 ITEM	零件代号 Part No	零件名	PART NAME	数量 Q'T Y	服务 代码 S.C	适用机号 SERIAL NO	互 换 性 IA	替换零件 REPLACEABLE	
								PART	
								零件代号 Part No	数量 Q' TY
1	860120904	活塞杆	Bar	1	D				
2	860120905	端盖	Cover	1					
3	860120906	缸体组件（左）	Cylinder	1	D				
4	860120907	缓冲套 d=85	Cushion	1					
5	860120908	活塞	Piston	1					
6	860120909	螺母 M62×3	Nut	1					
7	860120910	垫片		1					
8	860120911	B 型轴套	Bushing	2					
9	860120912	轴套	Bushing	1					
10	860120913	油管组件 A（左）	Pipe	1					
11	860120914	油管组件 B（左）	Pipe	1					
12	860120915	压板 YB-01	Pressing Plate	1					
13	860120916	卡箍组件	Clip	1					
①	860120917	防尘圈	Dust Seal	1					
②	860120918	挡圈	Ring,Back-Up	1					
③	860120919	轴用密封圈	Seal-Ring	1					
④	860120920	挡圈	Ring,Back-Up	1					
⑤	860120921	缓冲圈	Cushion	1					
⑥	860120922	内六角螺钉 M16×75	Screw	12					
⑦	860120923	滑动轴套	Bushing	1					
⑧	860120924	挡圈 Φ85×3	Ring,Back-Up	1					
⑨	860120925	O 形圈	O-Ring	1					
⑩	860120926	O 形圈挡圈	O-Back-Up Ring	1					
⑪	860120927	缓冲泄压环	Cushion	1					
⑫	860120928	孔用密封圈	Seal-Ring	1					
⑬	860120929	成型导向环	Guide Sleeve	2					
⑭	860120930	纳污环	Seal	2					
⑮	860120931	凹端螺钉 M12×12	Screw	1					
⑯	860120932	钢球 Φ8	Steel Ball	1					
⑰	860120933	内六角螺钉 M10×35	Screw	8					
⑱	860120934	O 形圈	O-Ring	2					
⑲	860120935	防尘圈	Dust Seal	2					
⑳	860120936	油杯 M10×1	Oiler	2					
㉑	860120937	螺栓 M14×80	Bolt	1					
㉒	860120938	螺母 M14	Nut	1					
㉓	860120939	弹簧垫圈	Spring Washer	1					
㉔	860120940	螺栓 M10×30	Bolt	2					

斗杆油缸 Arm Cylinder

序号 ITEM	零件代号 Part No	零件名	PART NAME	数量 Q'T Y	服务 代码 S.C	适用机号 SERIAL NO	互 换 性 IA	替换零件 REPLACEABLE PART	
								零件代号 Part No	数量 Q' TY
②4	860121020	螺栓 M10×40	Bolt	2					
②5	860121021	螺母 M10	Nut	2					
②6	860121022	弹簧垫圈 Φ10	Spring Washer	2					
②7	860121023	螺栓 M10×50	Bolt	1					
②8	860121024	弹簧垫圈 Φ10	Spring Washer	1					

CLICK HERE TO **DOWNLOAD** THE COMPLETE MANUAL

- Thank you very much for reading the preview of the manual.
- You can download the complete manual from: www.heydownloads.com by clicking the link below



- Please note: If there is no response to CLICKING the link, please download this PDF first and then click on it.

CLICK HERE TO **DOWNLOAD** THE COMPLETE MANUAL