

NISSAN
FORKLIFT

by **UNICARRIERS**

BARRETT

by **UNICARRIERS**

UNICARRIERS
A Lifetime of Trusted Value

PARTS MANUAL

MODEL 2W4

Platinum TGX Series Walkie Rider Tow Tractor
24V AC Powered
10,000 lb. Rolling Capacity / 225 lb. Drawbar Pull



PARTS

©UniCarriers Americas Corporation
240 N. Prospect Street, Marengo, IL 60152 USA
Tel: +1-815-568-0061 Fax: +1-815-568-0179
www.unicarriersamericas.com

PART NUMBER: CF850-UBOOK
PRINTING: OCTOBER 2013

CLICK HERE TO **DOWNLOAD** THE COMPLETE MANUAL

- Thank you very much for reading the preview of the manual.
- You can download the complete manual from: www.heydownloads.com by clicking the link below



- Please note: If there is no response to CLICKING the link, please download this PDF first and then click on it.

CLICK HERE TO **DOWNLOAD** THE COMPLETE MANUAL

CHASSIS SERIAL NUMBER

UniCarriers Americas Corporation MARIETTA, IL U.S.A.		
Model Number	1	
Serial Number	2	
3 Truck Type E	4 Battery Type E	Unit of Measure
5 DC voltage 24	Max. Grade %	kg (lb)
Capacity with Equally Distributed Load	6	
Truck Weight as Equipped Less Battery ±5%	7	
Battery Weight Maximum	8	
Battery Weight Minimum	9	
Battery Max. Amp Hr at 6 Hr Rate	10	
	11	

AS SHIPPED FROM THE FACTORY, THIS TRUCK CONFORMS TO ANSI/ISO 506.1

To choose correct parts always refer to the data plate, which is located on the backrest below the back pad.

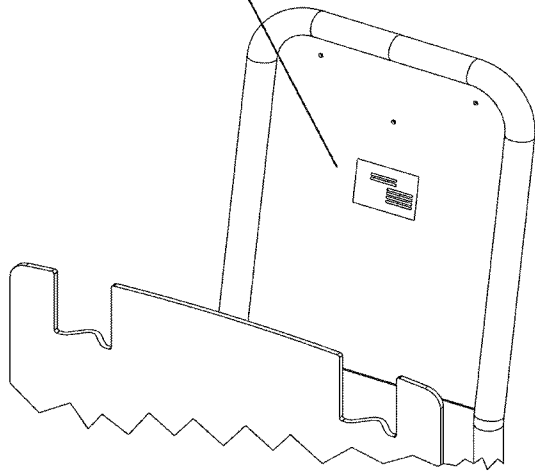

Chassis serial number is stamped in the frame by the transmission.

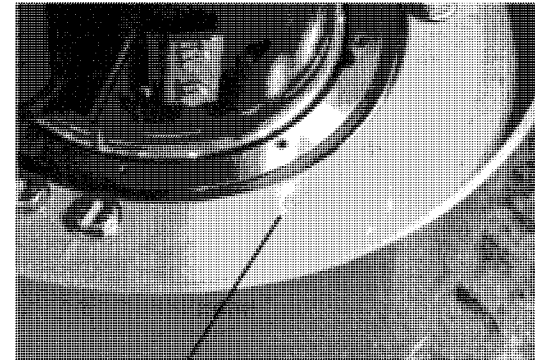

TRUCK SERIAL NUMBER IS ON CENTER PORTION OF FRAME

MODÈLE VARIATION (LONG CODE DE MODÈLE) VENTILATION

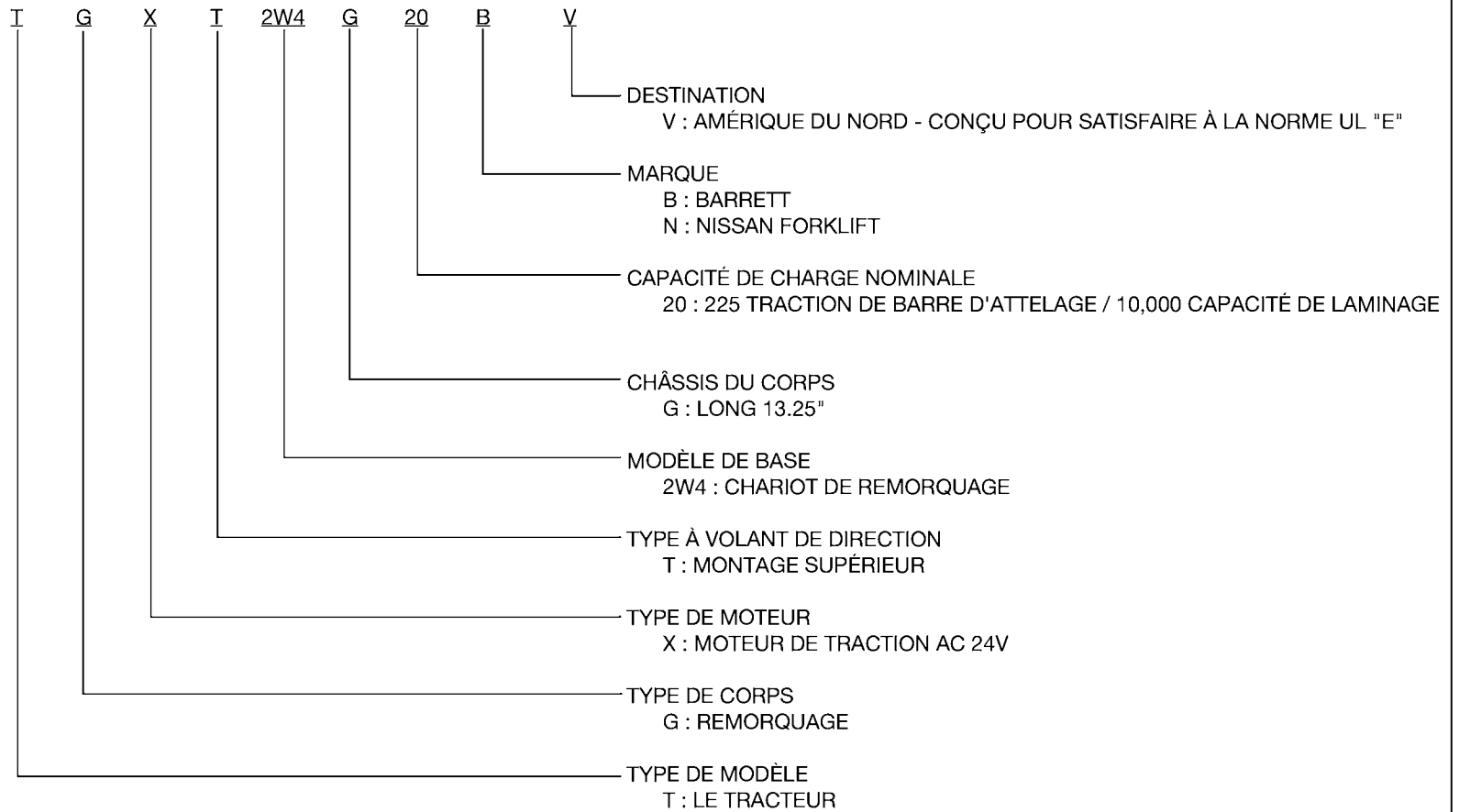

F-2

CLICK HERE TO **DOWNLOAD** THE COMPLETE MANUAL

- Thank you very much for reading the preview of the manual.
- You can download the complete manual from: www.heydownloads.com by clicking the link below



- Please note: If there is no response to CLICKING the link, please download this PDF first and then click on it.

CLICK HERE TO **DOWNLOAD** THE COMPLETE MANUAL

SEC. 260B

BATTERY GATE & ROLLER

PUERTA DE LA BATERÍA

TAMPA DA BATERIA

LA PORTE DE LA BATTERIE

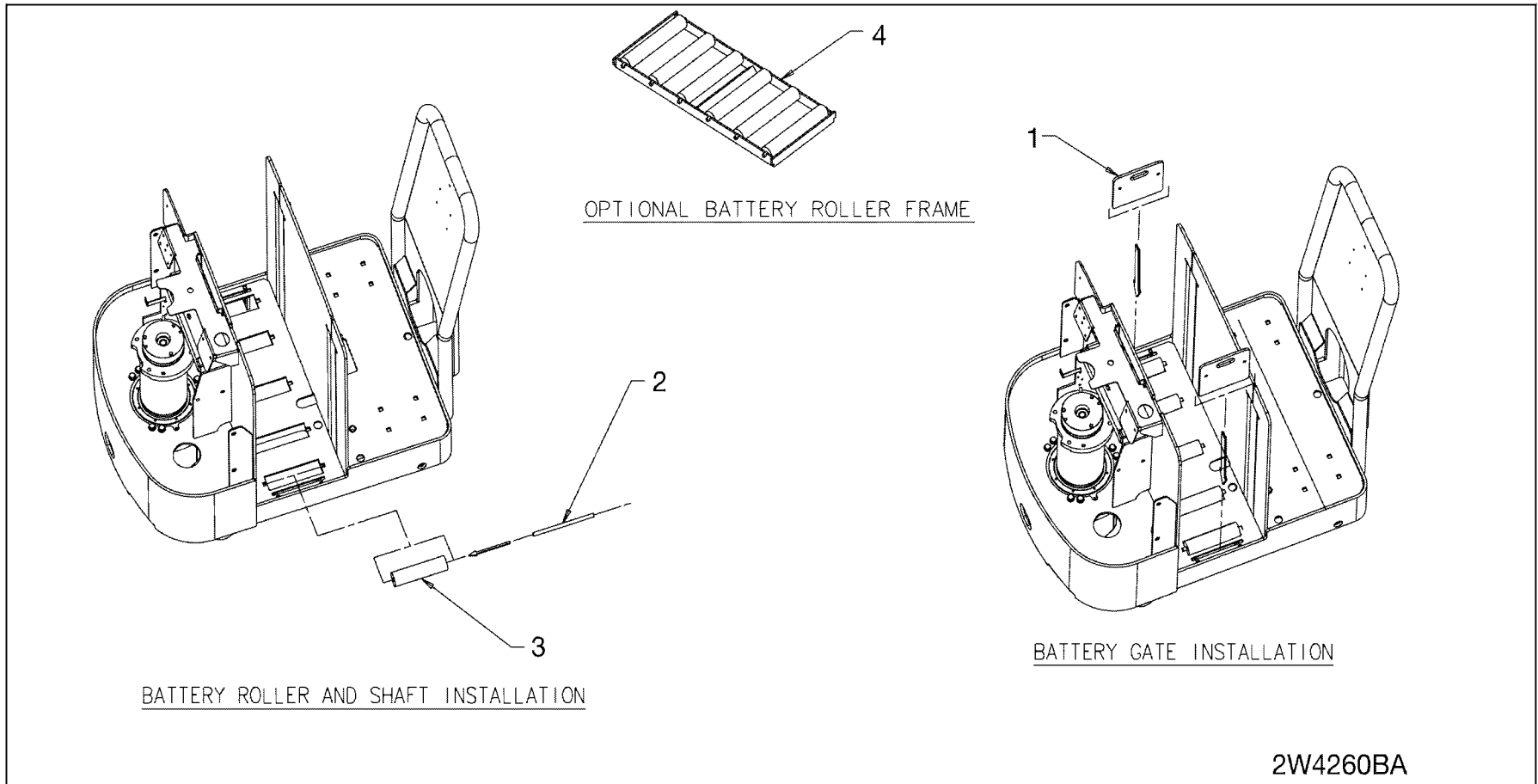

260B-1

2W4260BA

SEC. 420

LOAD WHEEL

RUEDA DE CARGA

RODA DE CARGA

ROUE PORTEUSE

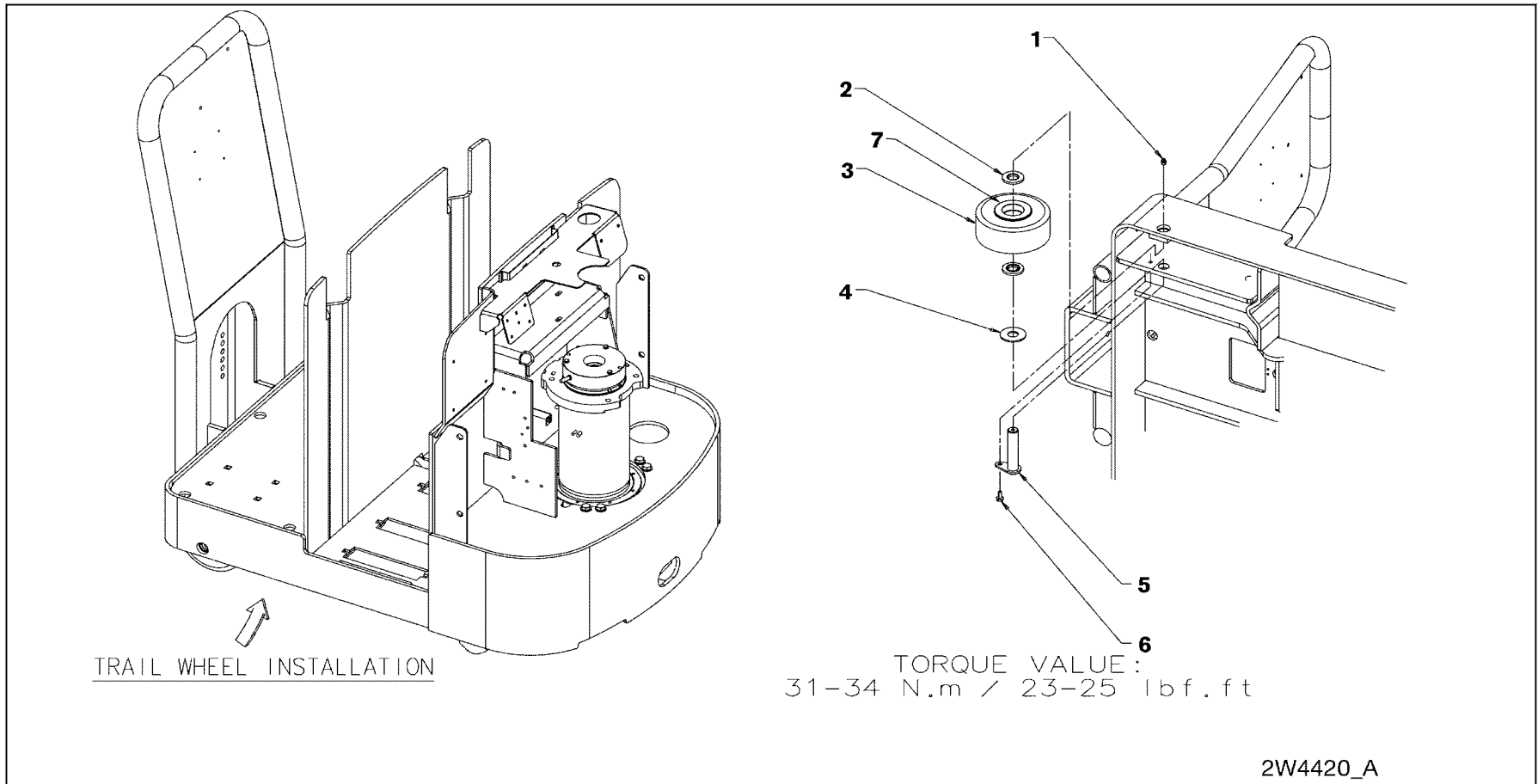

SEC. 483

STEER HANDLE ASSEMBLY

CONJUNTO DE PALANCA DE DIRECCIÓN

CONJUNTO ALÇA DIREÇÃO

STEER ENSEMBLE DE POIGNÉE

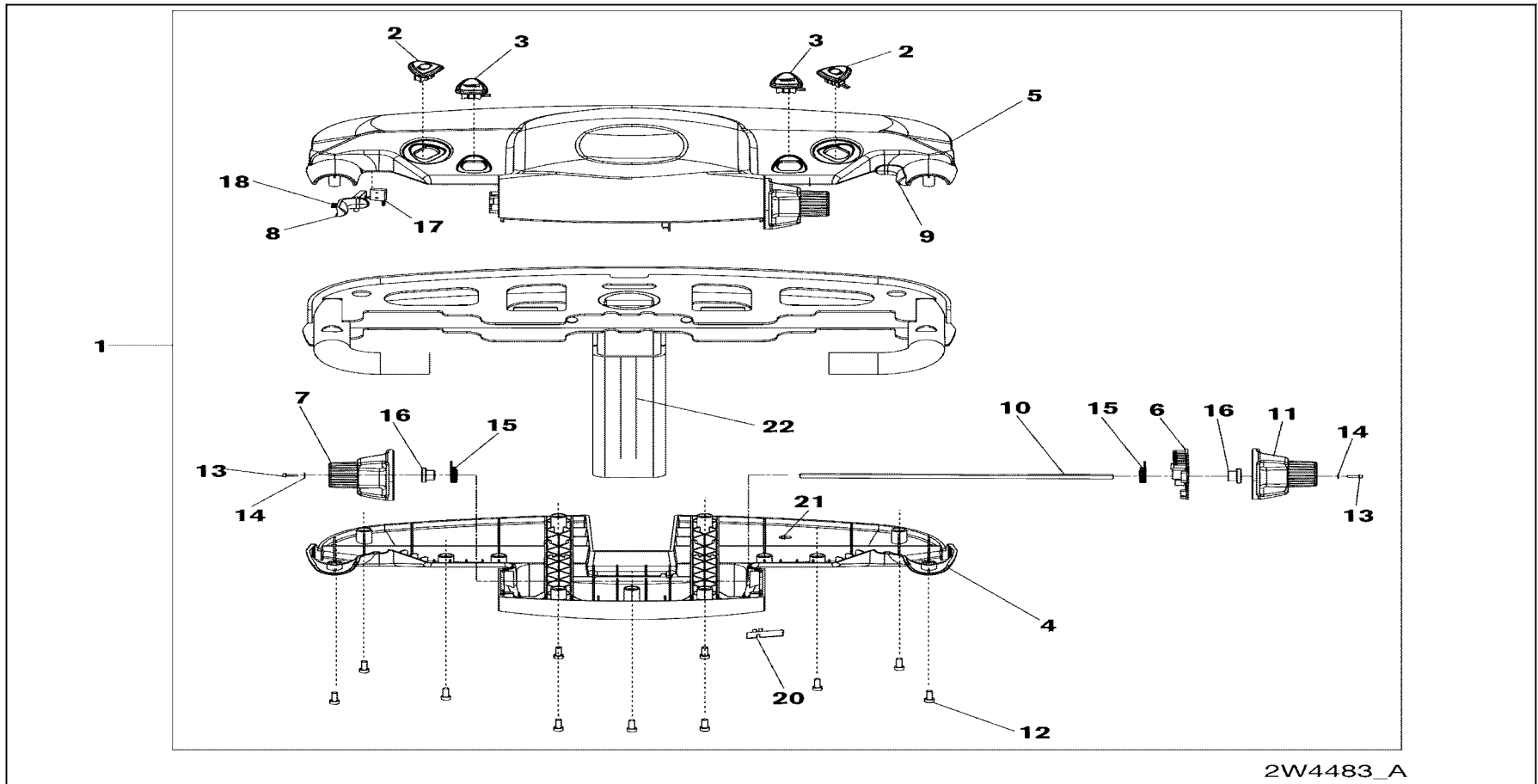

2W4483_A

SEC. 630

CONVENIENCE TRAY

BANDEJA AUXILIAR

TABULEIRO

TIROIR DE COMMODITÉ

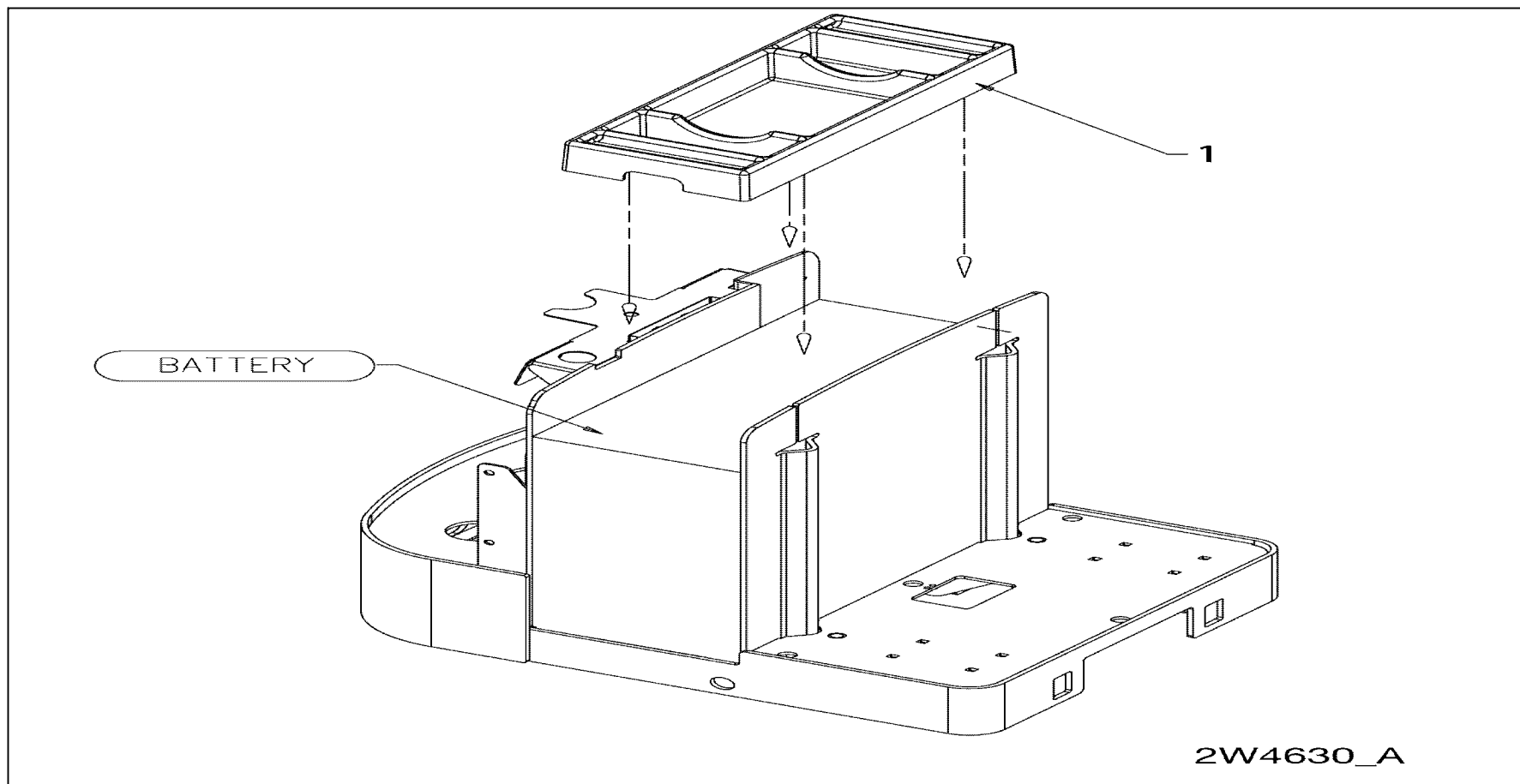

2W4630_A

630-1

SEC. 670

PICKING STEPS

RECOGIENDO LOS PASOS

A COLHEITA PASSOS

CUEILLETTE ÉTAPES

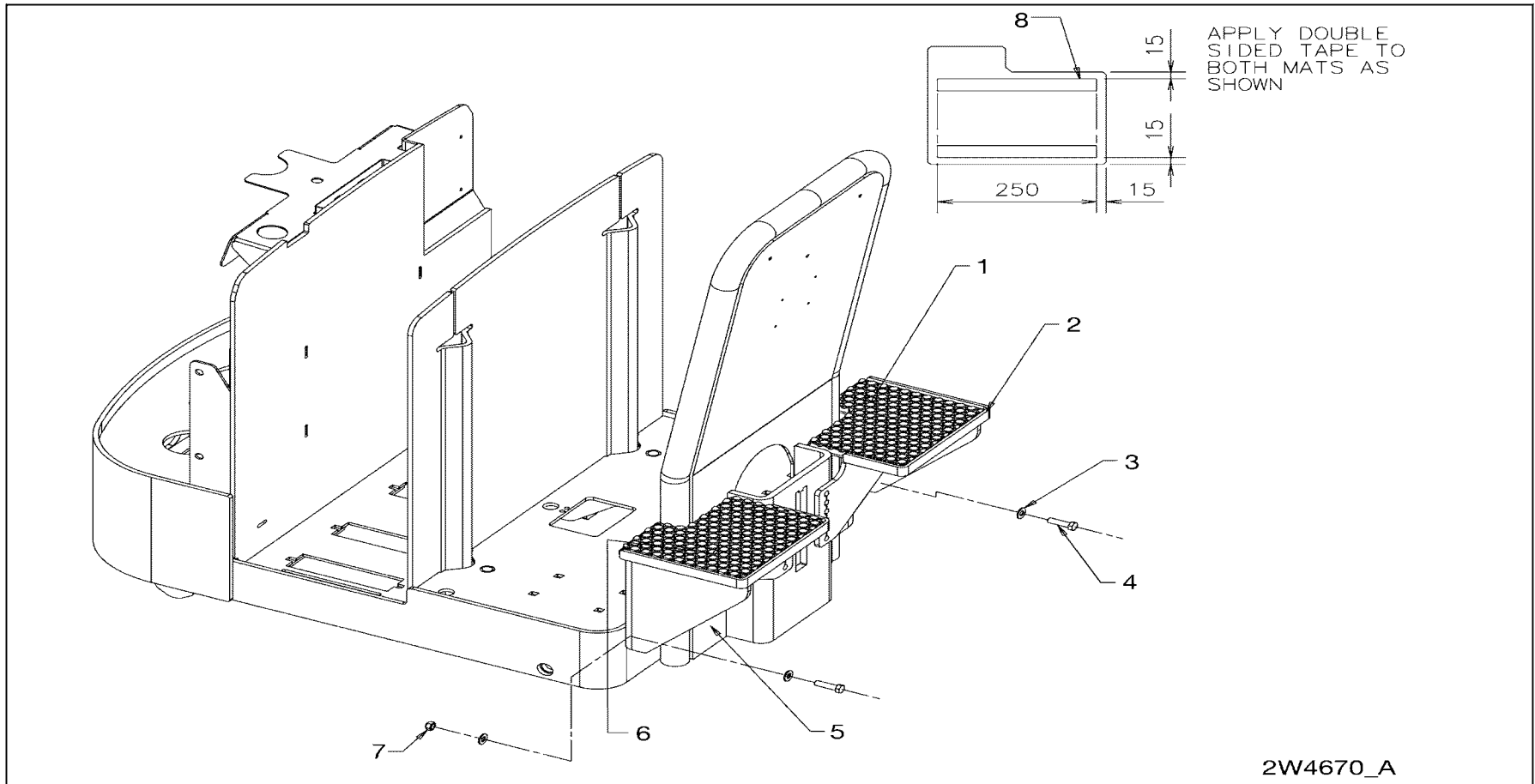

670-1

CLICK HERE TO **DOWNLOAD** THE COMPLETE MANUAL

- Thank you very much for reading the preview of the manual.
- You can download the complete manual from: www.heydownloads.com by clicking the link below



- Please note: If there is no response to CLICKING the link, please download this PDF first and then click on it.

CLICK HERE TO **DOWNLOAD** THE COMPLETE MANUAL