



UniCarriers Americas Corporation

# PARTS MANUAL

## MODEL E2W3

SPXE Series Center Control Walkie Rider Pallet  
24V AC Powered Electric / Electric Power Steering  
6,000 & 8,000 lb. Capacities



# PARTS

©UniCarriers Americas Corporation  
240 N. Prospect Street, Marengo, IL 60152 USA  
Tel: +1-815-568-0061 Fax: +1-815-568-0179  
[www.unicarriersamericas.com](http://www.unicarriersamericas.com)

PART NUMBER: 997PE-33100  
PRINTING: AUGUST 2017

CLICK HERE TO **DOWNLOAD** THE COMPLETE MANUAL

- Thank you very much for reading the preview of the manual.
- You can download the complete manual from: [www.heydownloads.com](http://www.heydownloads.com) by clicking the link below



- Please note: If there is no response to CLICKING the link, please download this PDF first and then click on it.

CLICK HERE TO **DOWNLOAD** THE COMPLETE MANUAL

## CHASSIS SERIAL NUMBER

UniCarriers Americas Corporation	
MARENGO, IL U.S.A.	
MODEL NUMBER	██████████
SERIAL NUMBER	██████████
TRUCK TYPE <b>E</b>	BATTERY TYPE <b>E</b>
DC VOLTAGE <b>24</b>	MAX. GRADE <b>5%</b>
UNIT OF MEASURE kg (lb)	
CAPACITY WITH EQUALLY DISTRIBUTED LOAD	██████████
TRUCK WEIGHT LESS BATTERY ±5%	██████████
BATTERY WEIGHT MAXIMUM	██████████
BATTERY WEIGHT MINIMUM	██████████
BATTERY MAX. AMP HR. AT 6 HR. RATE	██████████
AS SHIPPED FROM THE FACTORY, THIS TRUCK CONFORMS TO ANSI/ISO# B56.1 F502	

To choose correct parts always refer to the data plate, which is located on the backrest below the back pad.

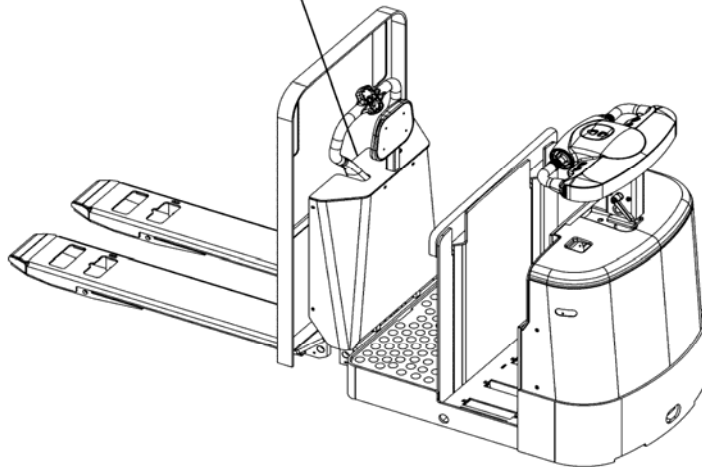

Chassis serial number is stamped on the center portion of frame.

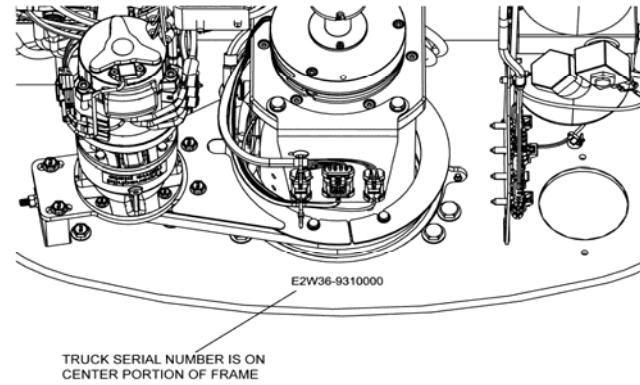







# SEC. 241B

## ELECTRICAL SCHEMATIC OPT

ESQUEMA ELÉCTRICO

ESQUEMA ELÉTRICO

SCHEMA DE CÂBLAGE ÉLECTRIQUE

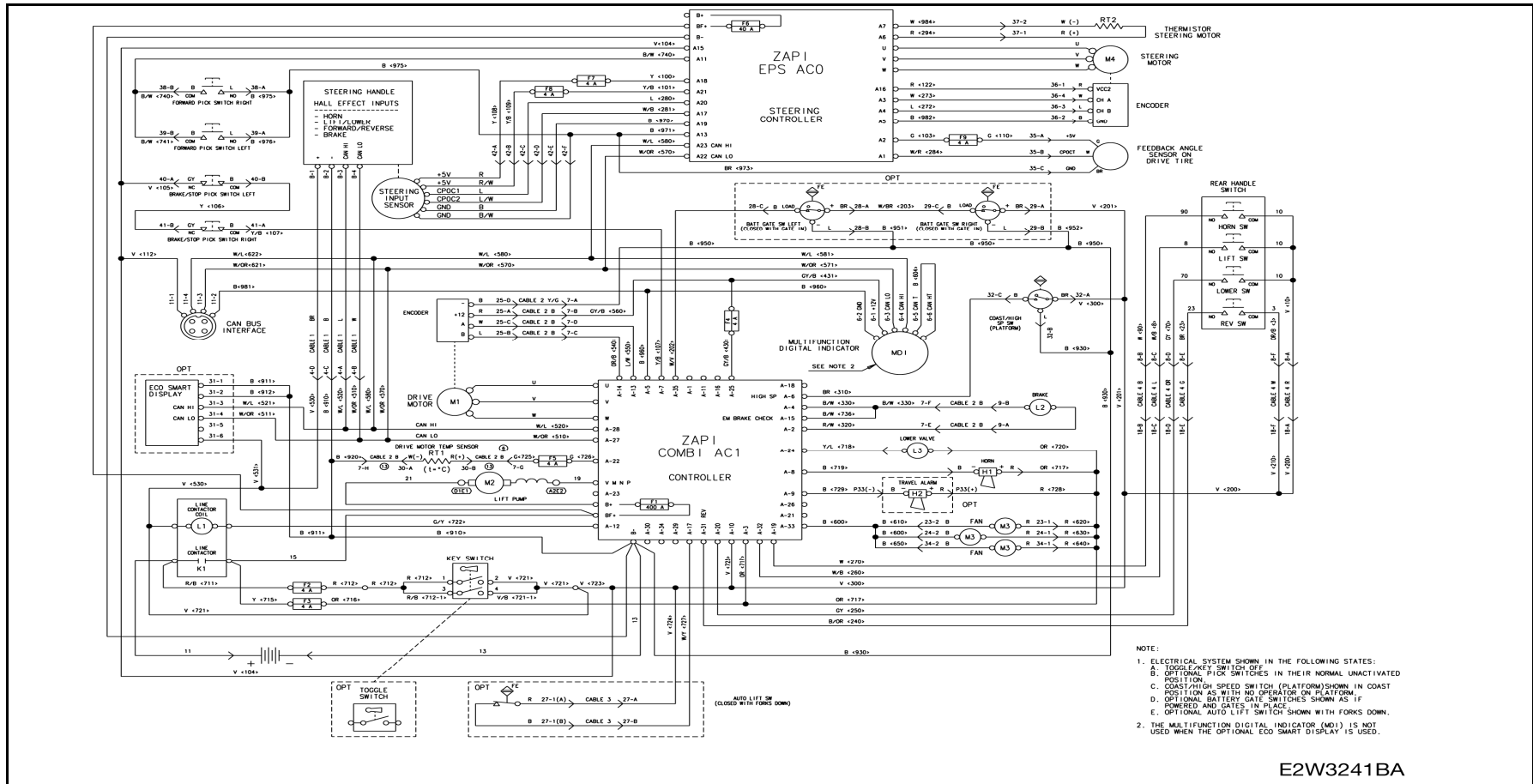

E2W3241BA

CLICK HERE TO **DOWNLOAD** THE COMPLETE MANUAL

- Thank you very much for reading the preview of the manual.
- You can download the complete manual from: [www.heydownloads.com](http://www.heydownloads.com) by clicking the link below



- Please note: If there is no response to CLICKING the link, please download this PDF first and then click on it.

CLICK HERE TO **DOWNLOAD** THE COMPLETE MANUAL















CLICK HERE TO **DOWNLOAD** THE COMPLETE MANUAL

- Thank you very much for reading the preview of the manual.
- You can download the complete manual from: [www.heydownloads.com](http://www.heydownloads.com) by clicking the link below



- Please note: If there is no response to CLICKING the link, please download this PDF first and then click on it.

CLICK HERE TO **DOWNLOAD** THE COMPLETE MANUAL