

UNI CARRIERS

UNI CARRIERS
A Lifetime of Trusted Value

TCM

BARRETT

by **UNI CARRIERS**

by **UNI CARRIERS**

PARTS MANUAL

MODEL 2W6

Platinum WSX Series Walkie Straddle Stacker
24V AC Powered
3,000-4,000 lb. Capacities



PARTS

©UniCarriers Americas Corporation
240 N. Prospect Street, Marengo, IL 60152 USA
Tel: +1-815-568-0061 Fax: +1-815-568-0179
www.unicarriersamericas.com

PART NUMBER: CF870-UBOOK
PRINTING: NOVEMBER 2014

CLICK HERE TO **DOWNLOAD** THE COMPLETE MANUAL

- Thank you very much for reading the preview of the manual.
- You can download the complete manual from: www.heydownloads.com by clicking the link below



- Please note: If there is no response to CLICKING the link, please download this PDF first and then click on it.

CLICK HERE TO **DOWNLOAD** THE COMPLETE MANUAL

CHASSIS SERIAL NUMBER

To choose correct parts always refer to the data plate, which is located above the meter panel area. On units with the Optional ECO Smart Display see illustration at right for location.

UNICARRIERS AMERICAS CORPORATION			
MODEL		BAT. TYPE	
SERIAL NO.		BAT. TYPE	
MAST		MAX. REAR TILT	DIG.
UPGRADEABILITY		VOLTAJE	V
ATTACHMENT			
BAL. W.	MAX.	MIN.	
A	LOAD CENTER	C	FOUR WHEELS
UNICARRIERS AMERICAS CORPORATION			

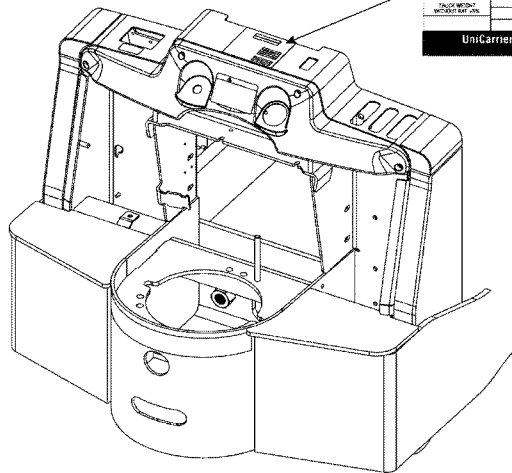

OPTIONAL ECO SMART DISPLAY

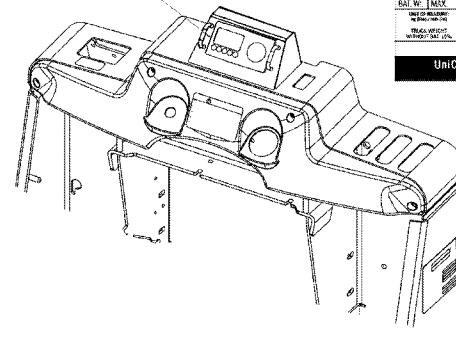

UNICARRIERS AMERICAS CORPORATION			
MODEL		BAT. TYPE	
SERIAL NO.		BAT. TYPE	
MAST		MAX. REAR TILT	DIG.
UPGRADEABILITY		VOLTAJE	V
ATTACHMENT			
BAL. W.	MAX.	MIN.	
A	LOAD CENTER	C	FOUR WHEELS
UNICARRIERS AMERICAS CORPORATION			

Chassis serial number is stamped in the frame by the transmission.

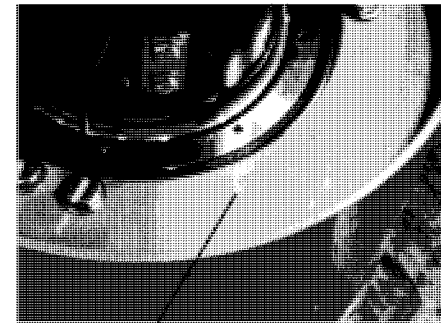

TRUCK SERIAL NUMBER IS ON CENTER PORTION OF FRAME

MODÈLE VARIATION (LONG CODE DE MODÈLE) VENTILATION

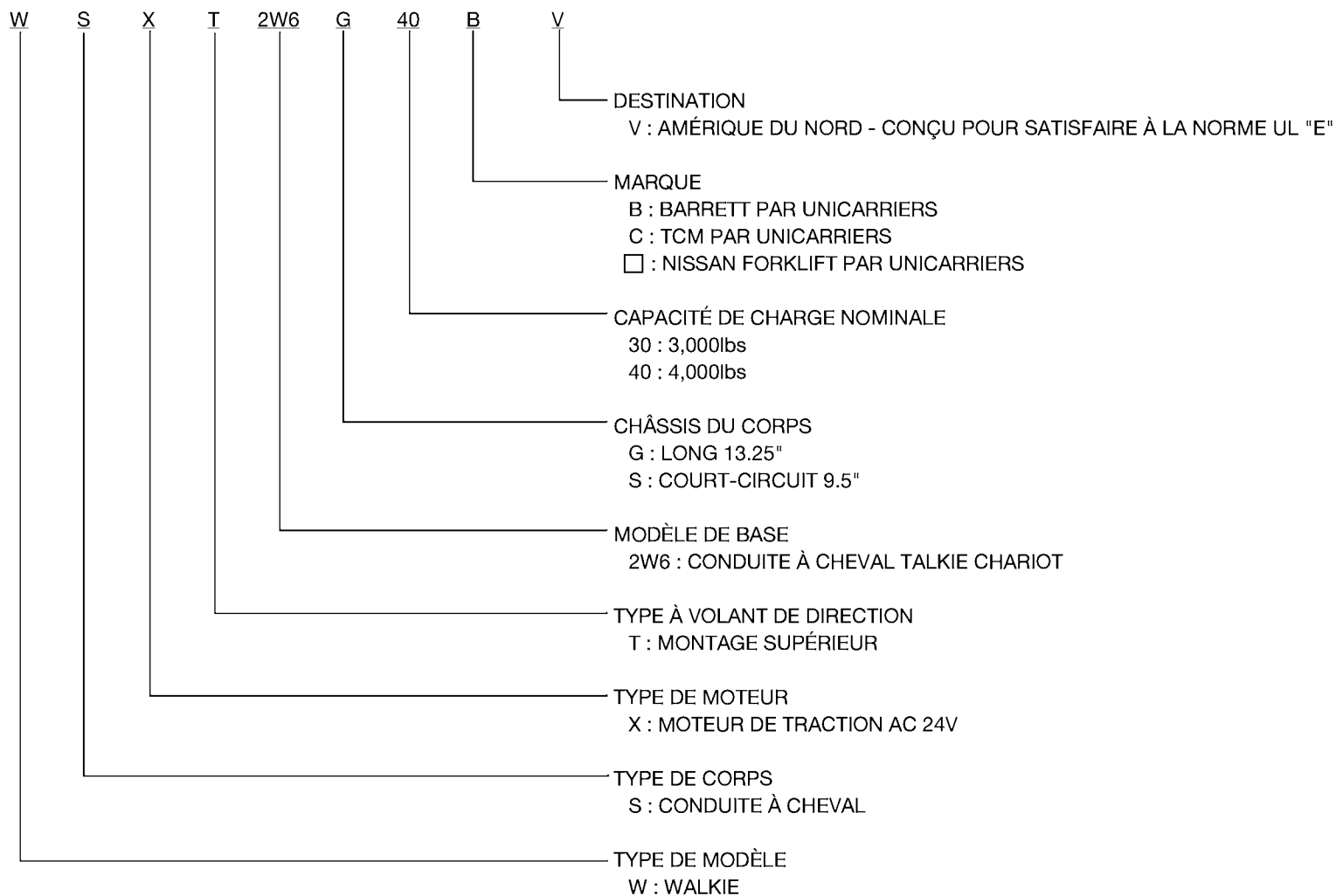

SEC. 243

CONTROL WIRING

CABLEADO DE CONTROL

FIAÇÃO DE CONTROLE

CONTRÔLE CÂBLAGE

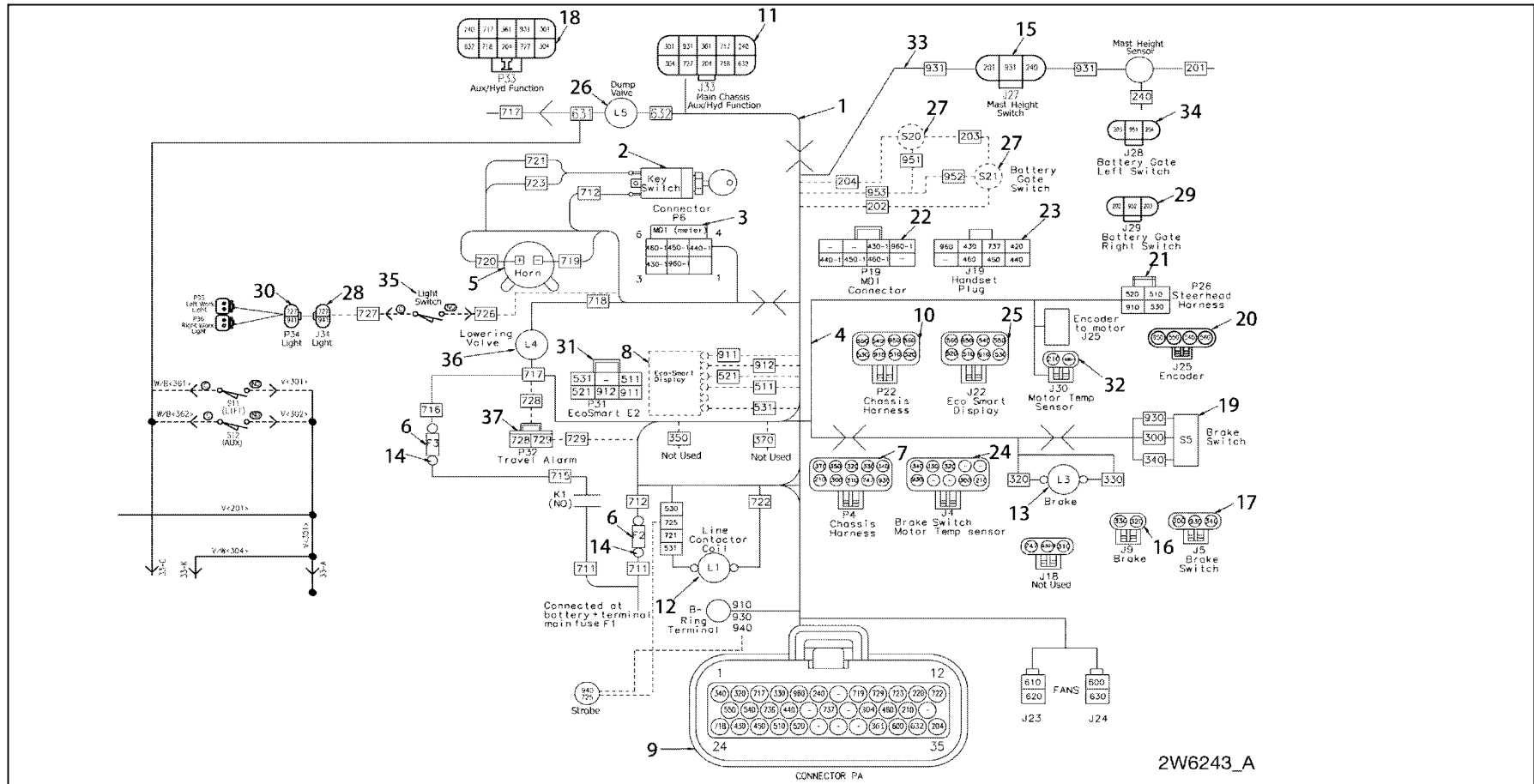

SEC. 260B

BATTERY GATE & ROLLER

PUERTA DE LA BATERÍA

TAMPA DA BATERIA

LA PORTE DE LA BATTERIE

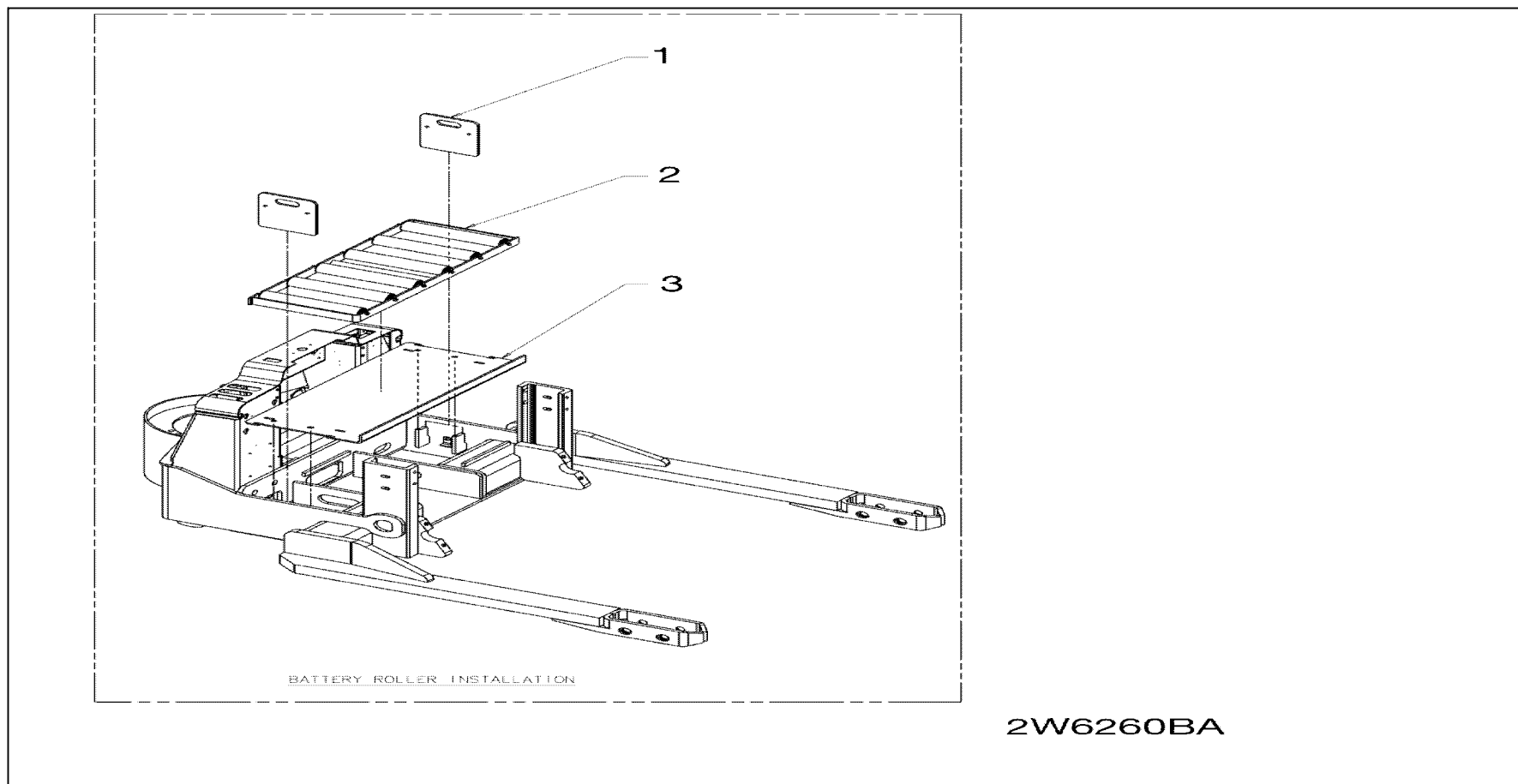

2W6260BA

260B-1

SEC. 310

TRANSMISSION ASSEMBLY

CONJUNTO DE LA TRANSMISIÓN

CONJUNTO DE TRANSMISSÃO

ENSEMBLE DE TRANSMISSION

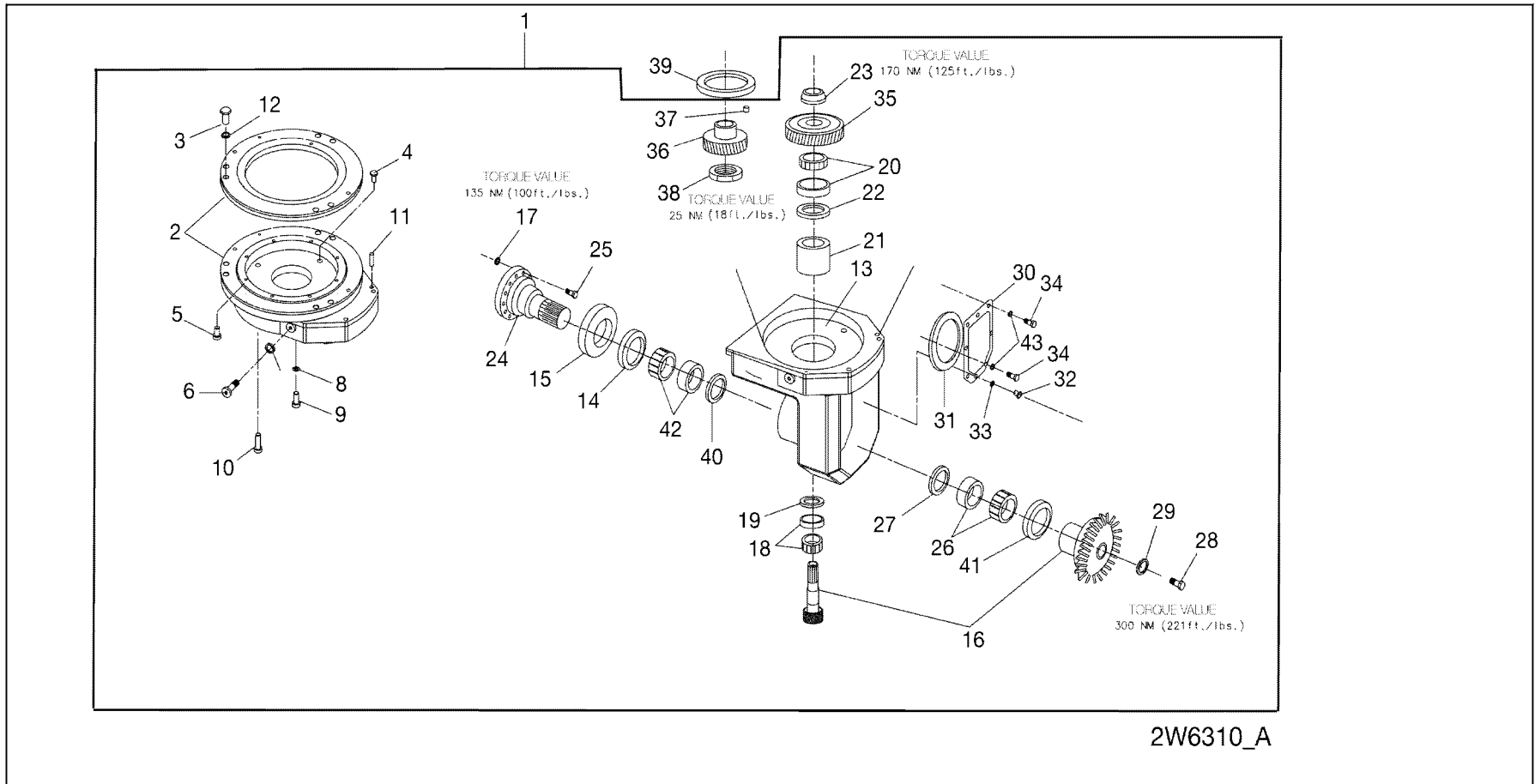

2W6310_A

CLICK HERE TO **DOWNLOAD** THE COMPLETE MANUAL

- Thank you very much for reading the preview of the manual.
- You can download the complete manual from: www.heydownloads.com by clicking the link below



- Please note: If there is no response to CLICKING the link, please download this PDF first and then click on it.

CLICK HERE TO **DOWNLOAD** THE COMPLETE MANUAL

SEC. 420

LOAD WHEEL

RUEDA DE CARGA

RODA DE CARGA

ROUE PORTEUSE

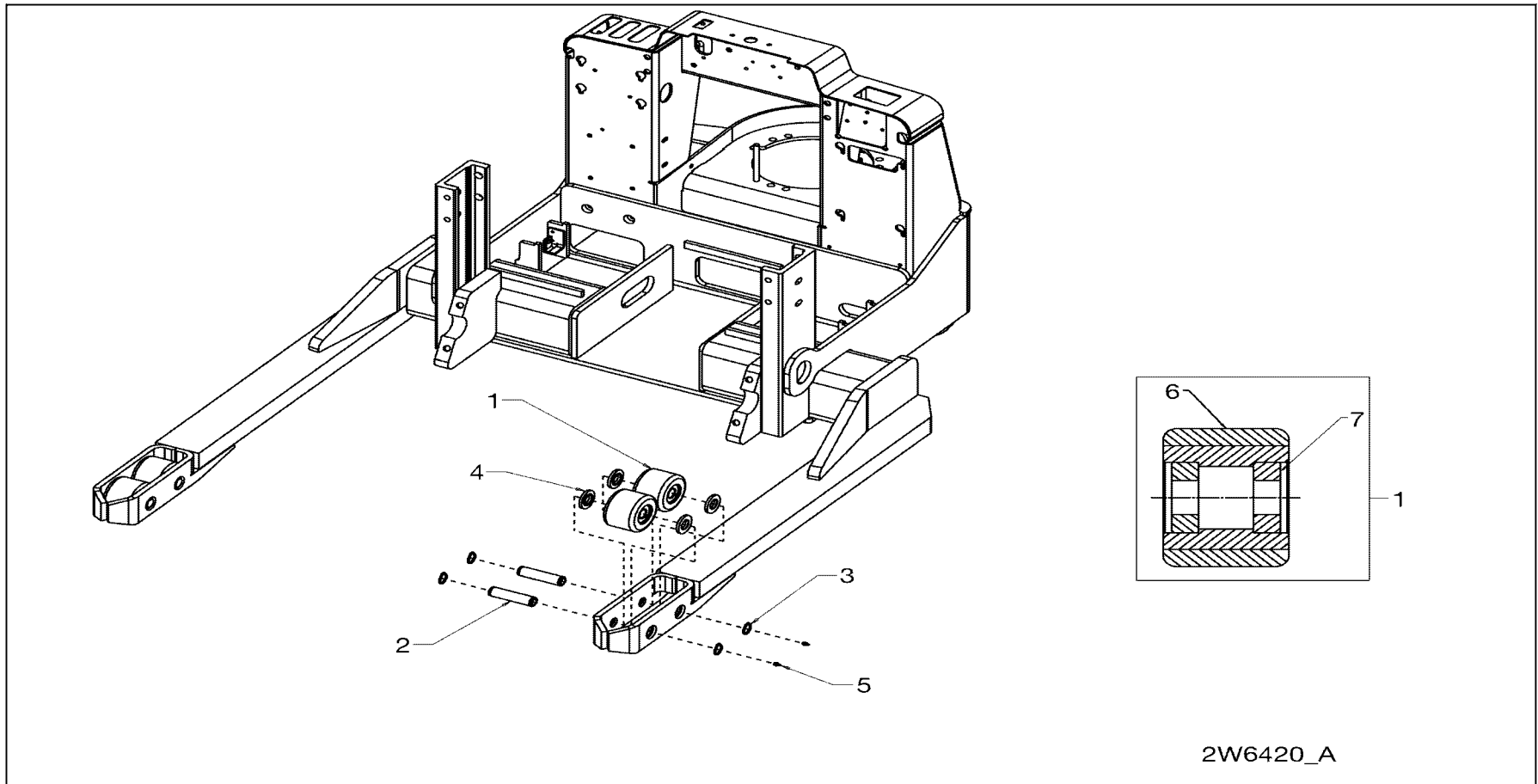

2W6420_A

420-1

SEC. 481

BRAKE HANDLE ASSEMBLY

CONJUNTO DE PALANCA DE FRENO

MONTAGEM DO CABO DO FREIO

POIGNÉE DE FREIN

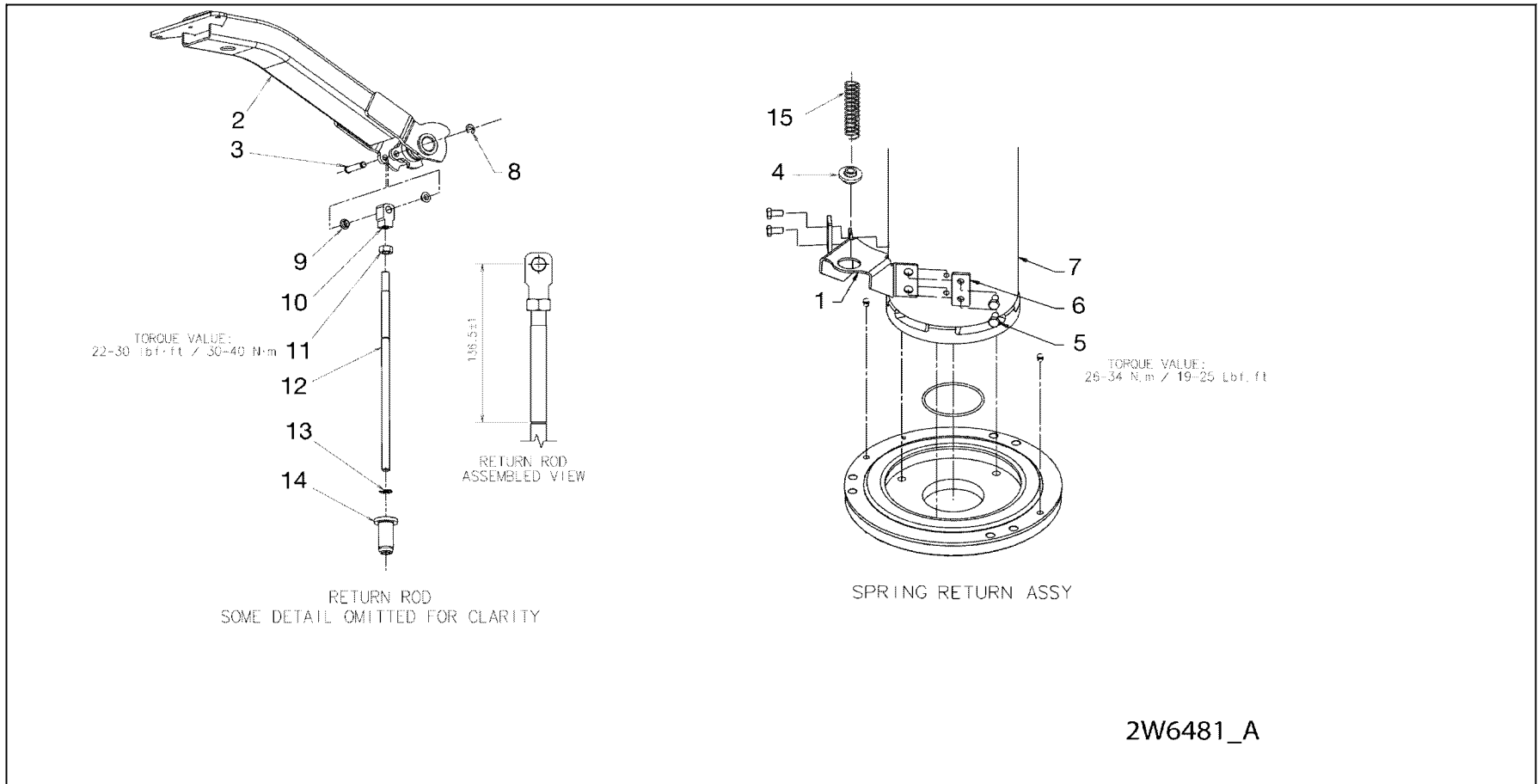

SEC. 580A

LIFT CYLINDER 2W

CILINDRO DE ELEVACION

CILINDRO DE ELEVAÇÃO

CYLINDRE DE LEVAGE

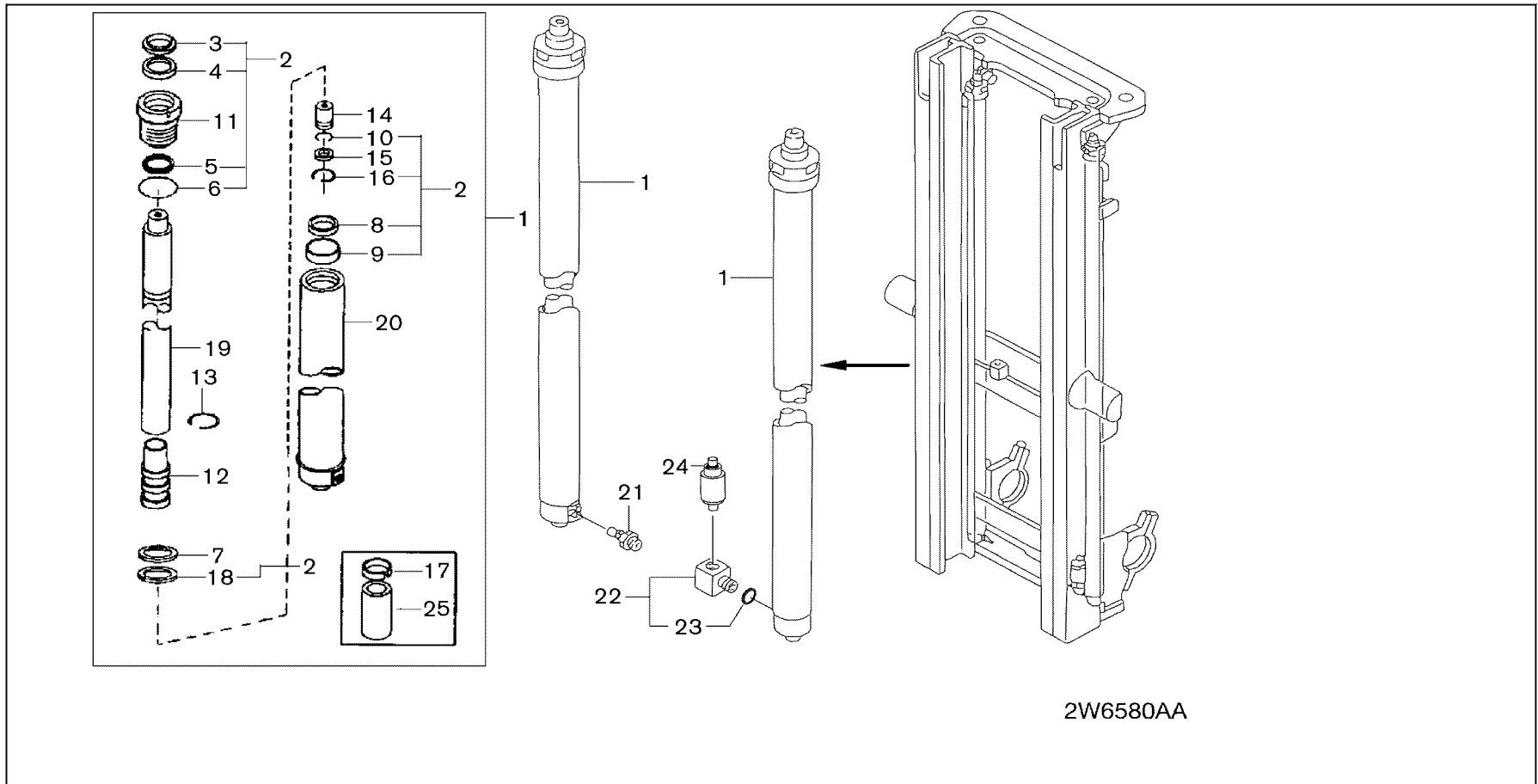

580A-1

SEC. 585B

CHAIN WHEEL SUPPORT & CHAIN 3F

SOPORTE DE LA RUEDA DE CADENA Y CADENA

SUPORTE DA RODA DA CORRENTE & CADEIA

SUPPORT DE ROUE DE CHAINE ET CHAINE

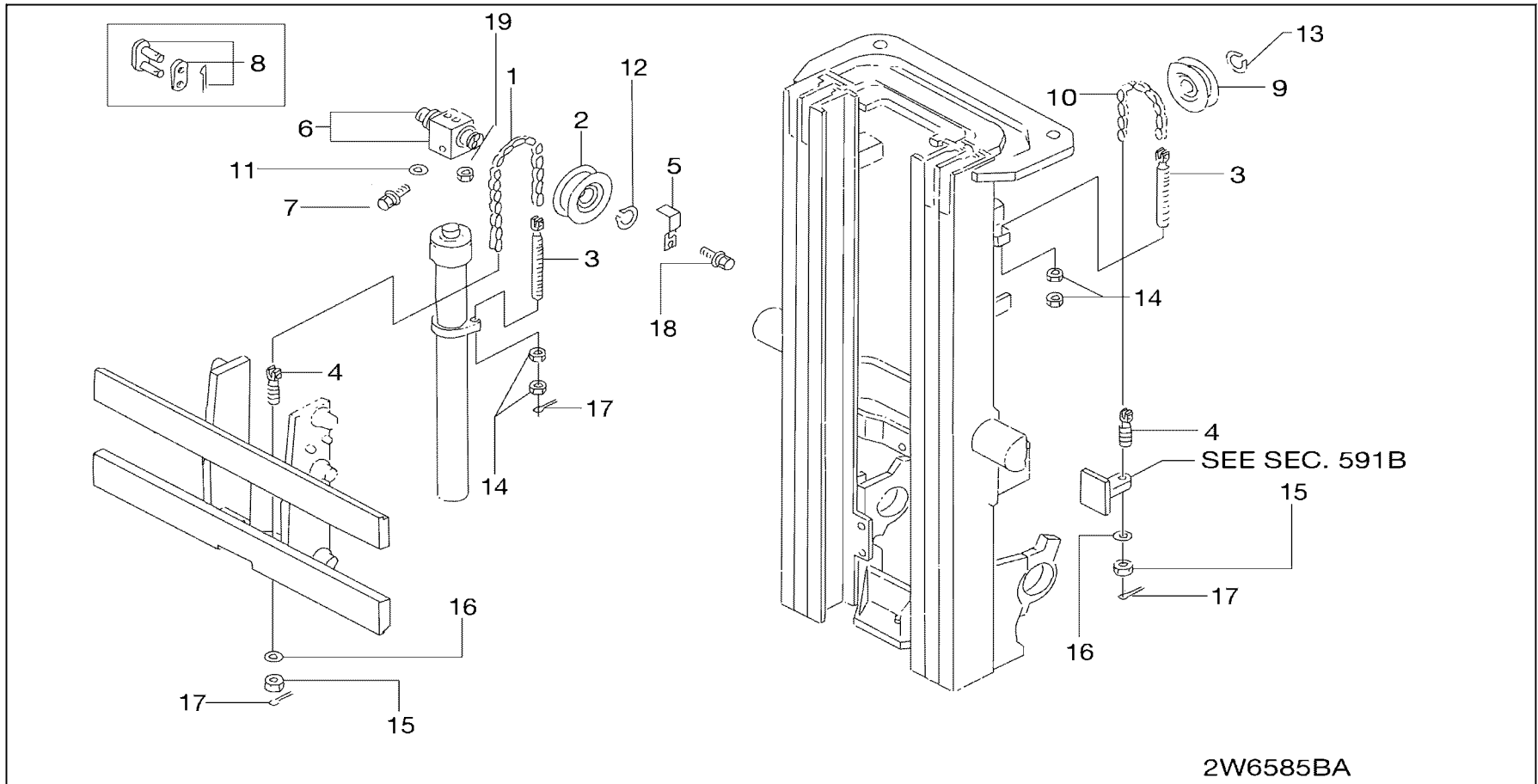

585B-1

SEC. 620*2

WASH DOWN PACKAGE PART 2

LAVE EL PAQUETE

LAVAR EMBALAGEM

LAVER LE BAS PACKAGE

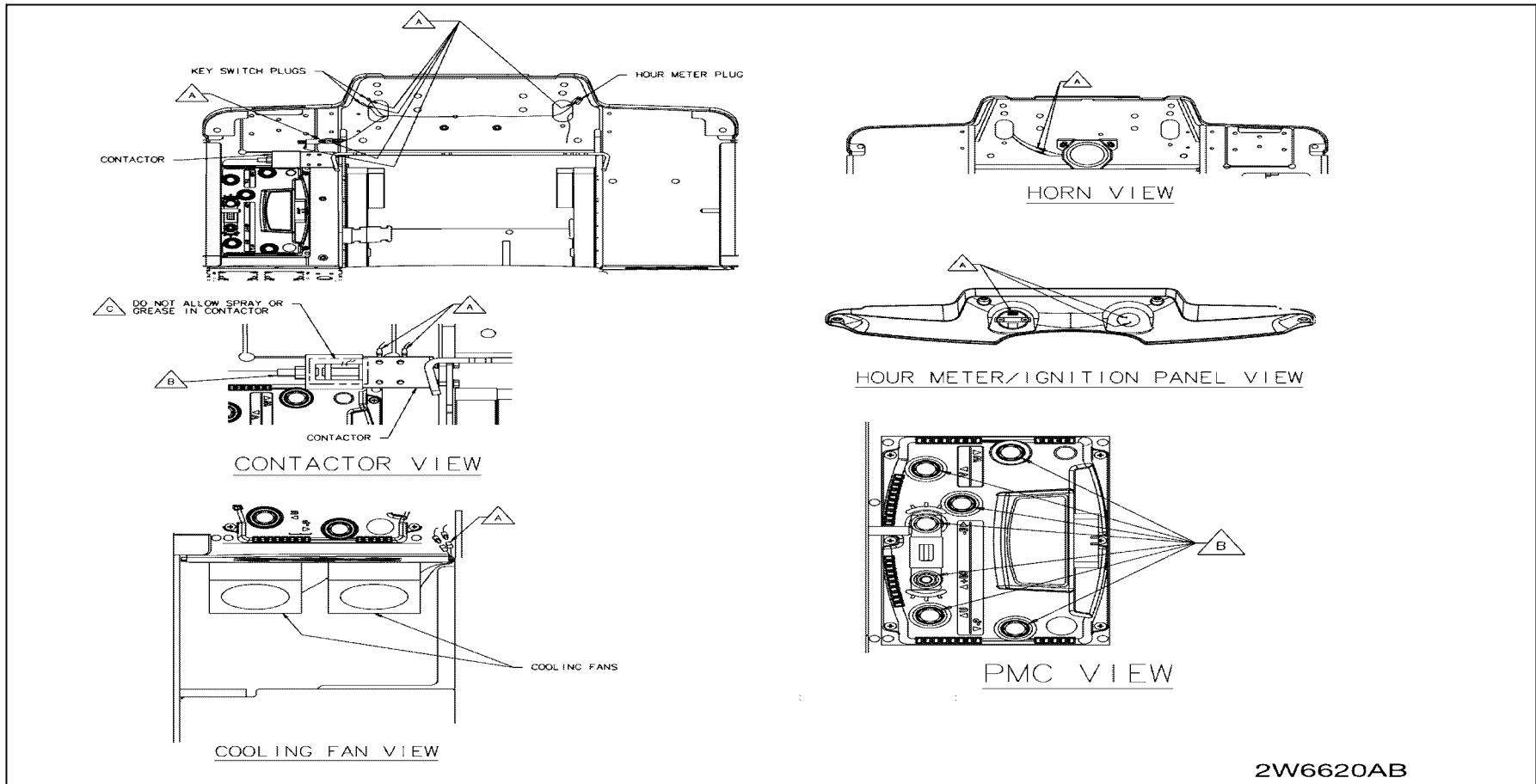

2W6620AB

620*2-1

SEC. 693B

HYDRAULIC CONTROL VALVE -COMBO MANUAL/ELECTRIC

VALVULA DE CONTROL HIDRAULICO

VÁLVULA DE CONTROLE HIDRÁULICO

SOUPAPE DE COMMANDE HYDRAULIQUE

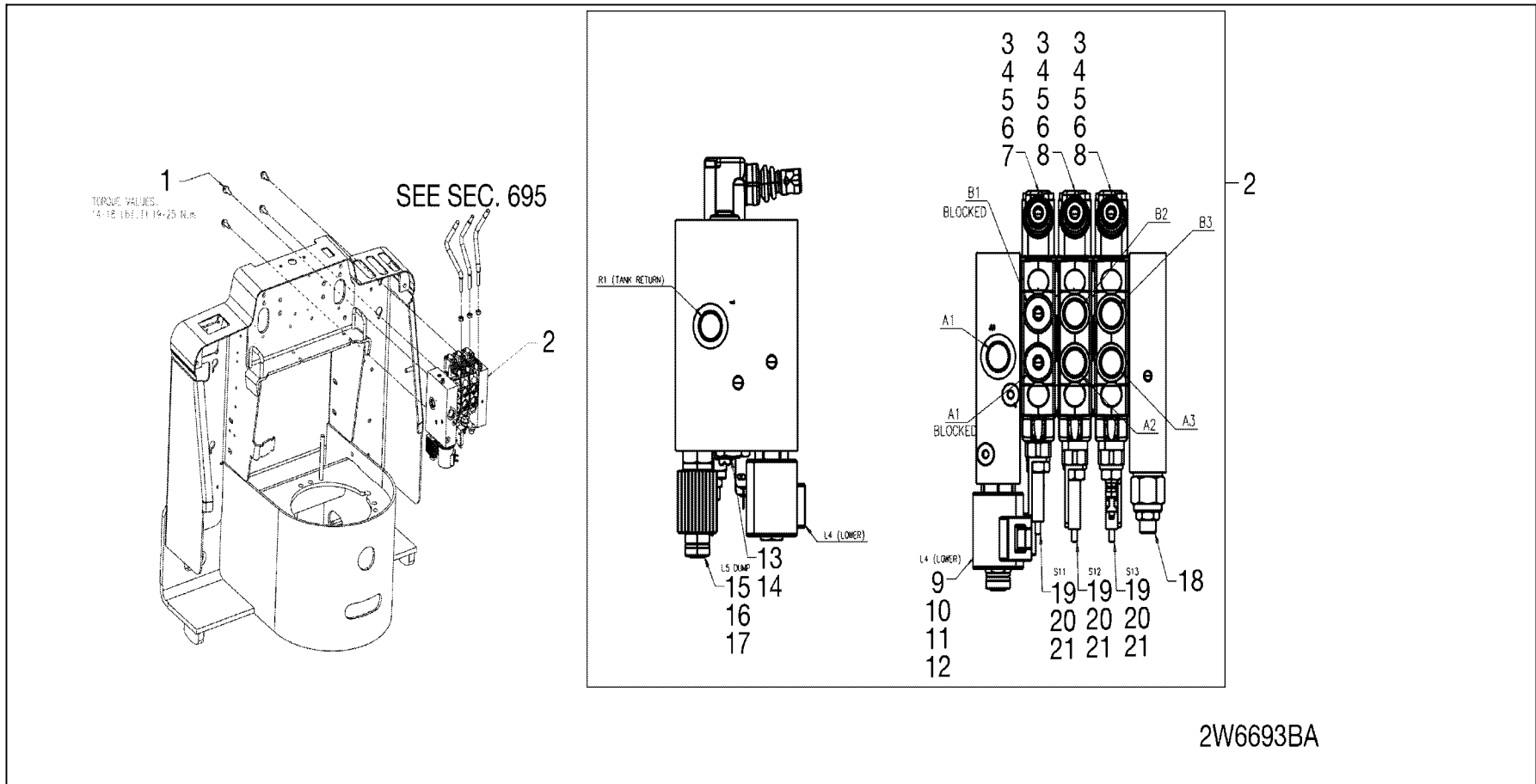

693B-1

SEC. 699B

HYDRAULIC OIL PIPING (ATTACHMENT) 2W

TUBERIA DE ACEITE HIDRAULICO ACCESORIOS

TUBULAÇÃO DE ÓLEO HIDRÁULICO (ACESSÓRIO)

CANALISATIONS HYDRAULIQUE ACCESSOIRES

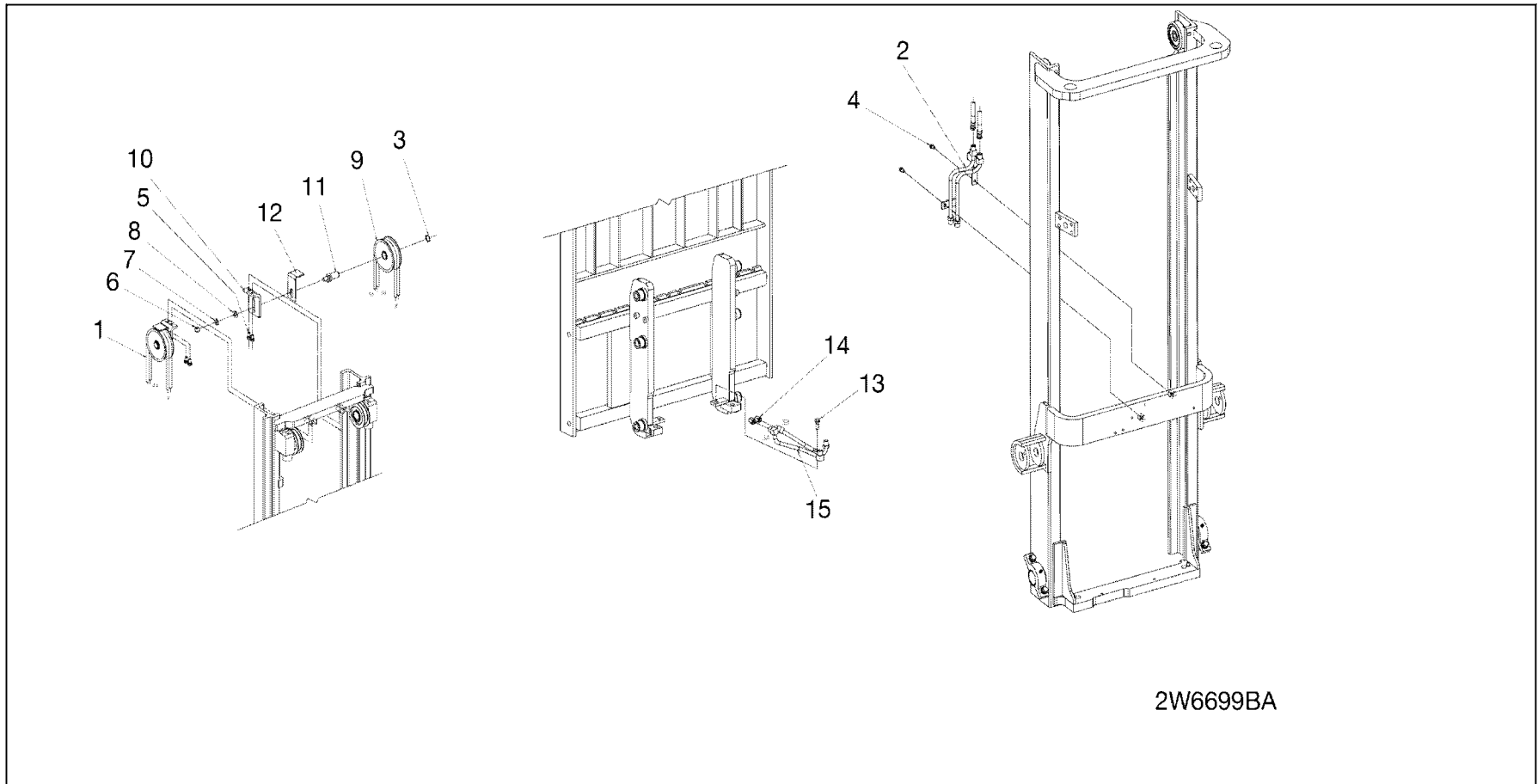

699B-1

CLICK HERE TO **DOWNLOAD** THE COMPLETE MANUAL

- Thank you very much for reading the preview of the manual.
- You can download the complete manual from: www.heydownloads.com by clicking the link below



- Please note: If there is no response to CLICKING the link, please download this PDF first and then click on it.

CLICK HERE TO **DOWNLOAD** THE COMPLETE MANUAL