

TM-ZX500 41050601274A FRAME

PB0000386-00 SYSTEM (ZX500SL,DOMESTIC)

ASSEMBLY

CLICK HERE TO **DOWNLOAD** THE COMPLETE MANUAL

- Thank you very much for reading the preview of the manual.
- You can download the complete manual from: www.heydownloads.com by clicking the link below



- Please note: If there is no response to CLICKING the link, please download this PDF first and then click on it.

CLICK HERE TO **DOWNLOAD** THE COMPLETE MANUAL

TM-ZX500 41050601274A FRAME
PB1100314-00 PUMP, HYDRAULIC (52CC:R)

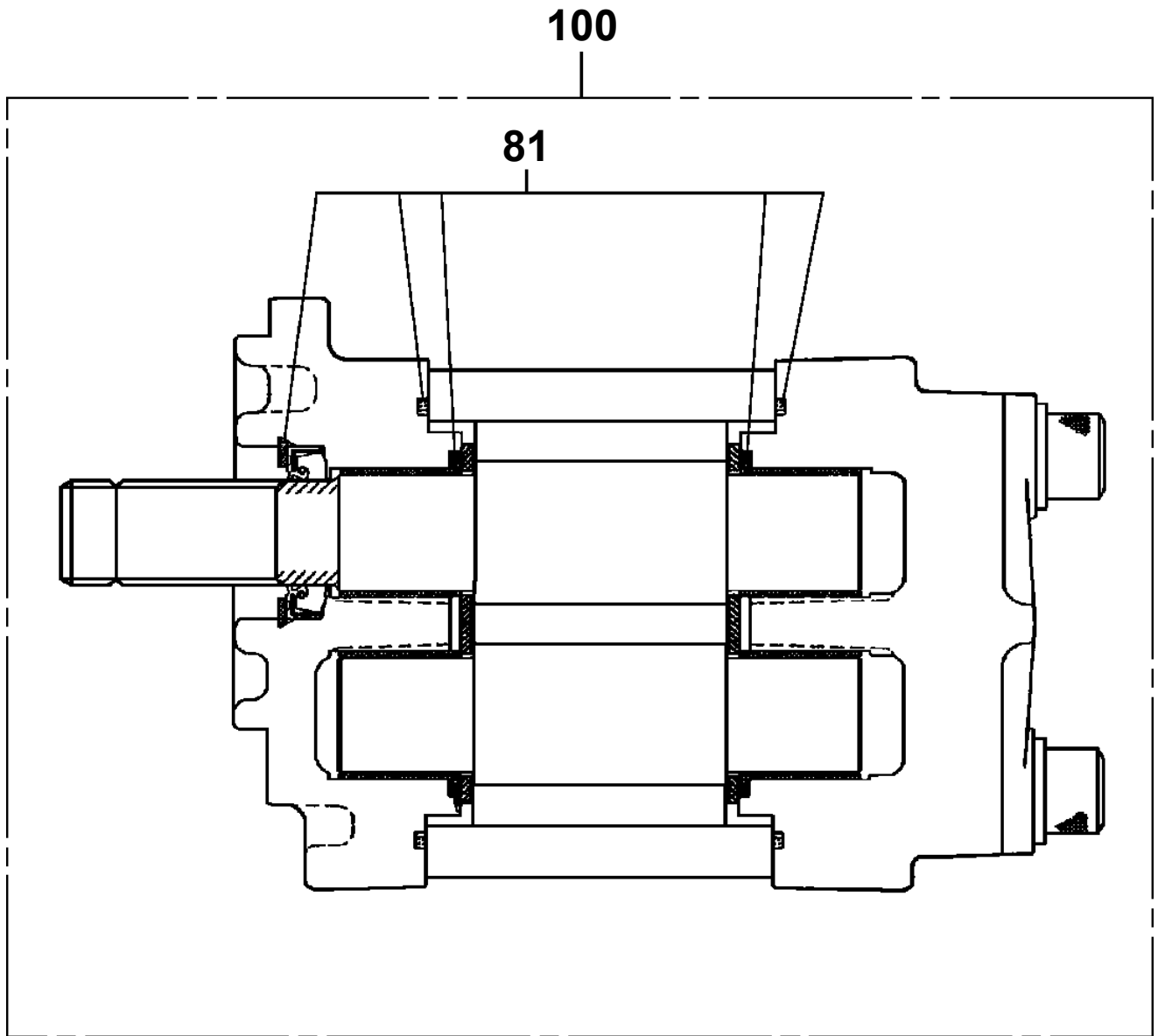

TM-ZX500 41050601274A FRAME

PB1380332-03 POWER SUPPLY (100V POWER SOURCE/1500W)

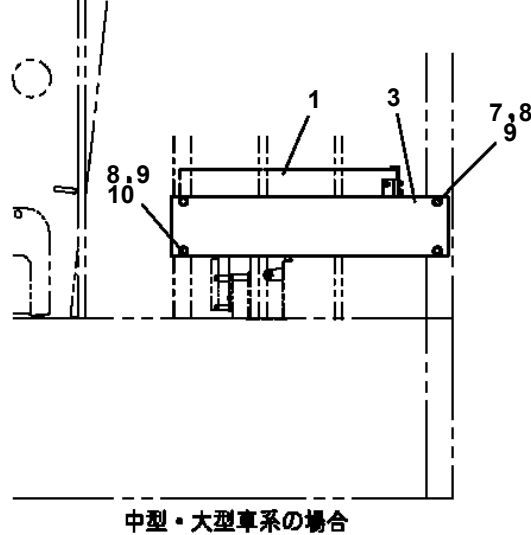
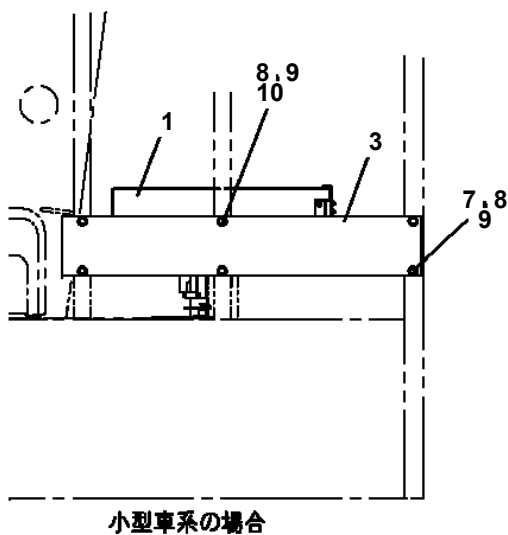
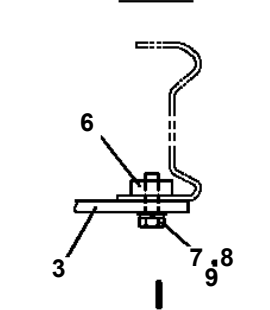
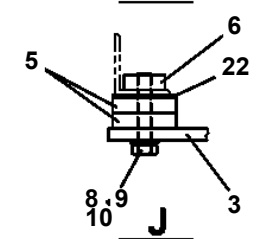
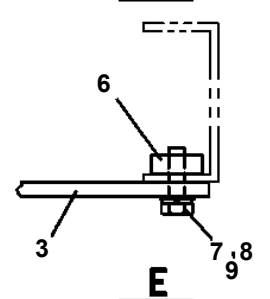
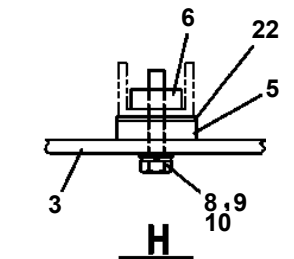
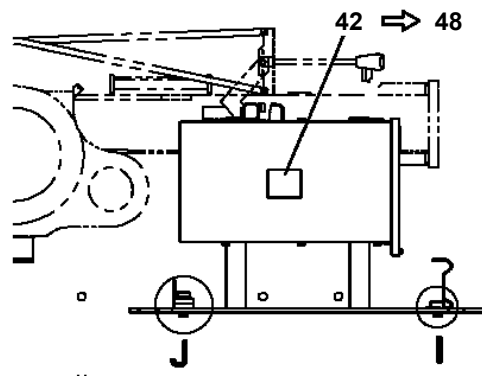
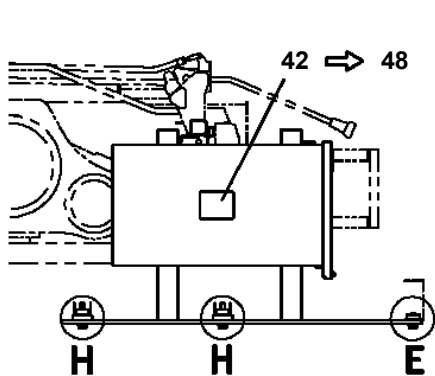
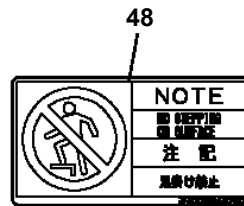
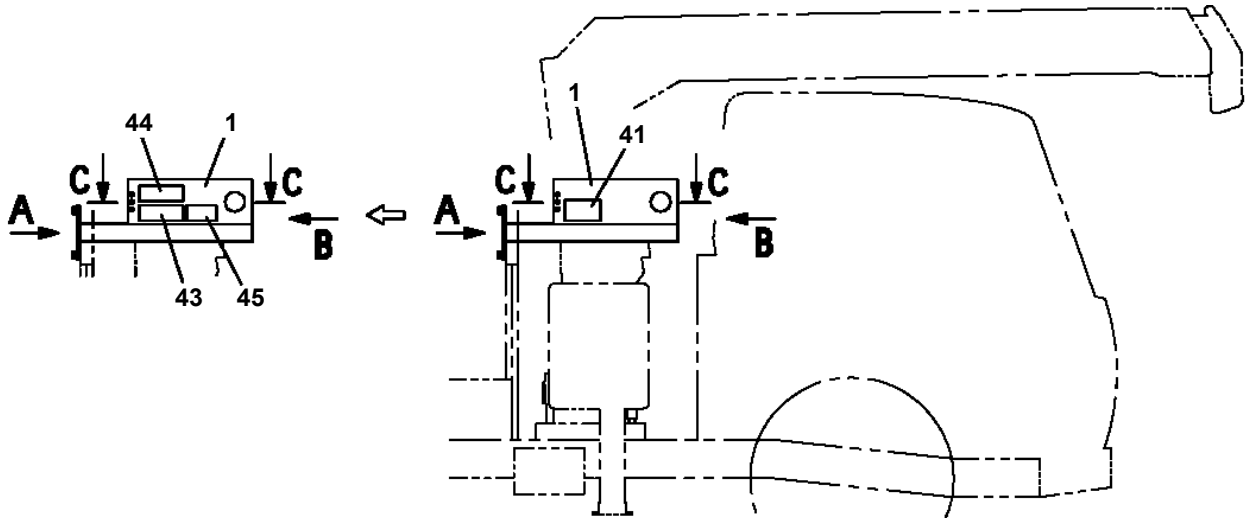

TM-ZX500 41050601274A FRAME

Pos No.	Parts No	Parts Name	Qty	Unit	Technical Data	Serial No (Start)	Serial No
1	33731351000	BLOCK	2		500X500,H=90		
10	31506860000	BLOCK (2 PIECE SET:PLATE,500X500,H=90)	1				

TM-ZX500 41050601274A FRAME

Pos No.	Parts No	Parts Name	Qty	Unit	Technical Data	Serial No (Start)	Serial No (End)
1	36620990000	VALVE,PILOT CHECK	1				
2	90172110035	BOLT,HEXAGON SOCKET	2		M10X35		
3	90172110025	BOLT,HEXAGON SOCKET	4		M10X25		
4	90302041001	WASHER,SPRING	4		10		
5	36032650001	CYLINDER,JACK	1				
11	36032651000	CYLINDER	1				
12	80136363071	PIN,SPLIT	1		6.3X71		
13	37001600000	NUT,CASTLE	1		M36		
14	36032654000	ROD	1				
15	91350207500	BEARING,PLAIN (WITH PACKINGX2)	1				
16	91002803400	O-RING	1		1B P34		
17	36032652000	PISTON	1				
18	36030643000	COVER,ROD	1				
19	91002907000	O-RING	1		1B G70		
20	91694006000	PACKING	1				
21	91410206002	RING,BACKUP	1				
22	36010130030	WASHER	1				
23	91660006000	SEAL,DUST	2				
24	80622000600	RING,RITAINING	1		SP60		
30	36032659900	PACKING SET	1		60X75		

TM-ZX500 41050601274A FRAME

Pos No.	Parts No	Parts Name	Qty	Unit	Technical Data	Serial No (Start)	Serial No (End)
1	36044301000	CYLINDER (RIGHT)	1				
2	90201201800	NUT	1		M18		
3	91100104000	SEAL,RING	1				
4	36043560100	PISTON	1				
5	36043652001	ROD	1				
6	36041541000	COVER,ROD	1				
7	91002803900	O-RING	1		1B P39		
8	91694003000	PACKING	1				
9	91411203001	RING,BACKUP	1				
10	91660003001	SEAL,DUST	1				
11	91002802000	O-RING	1		1B P20		
40	36043569900	PACKING SET	1		30X40		
100	36044300000	CYLINDER ASSY,EXTENSION (RIGHT)	1				

TM-ZX500 41050601274A FRAME
PE5020077-03 ELEC.ASSY

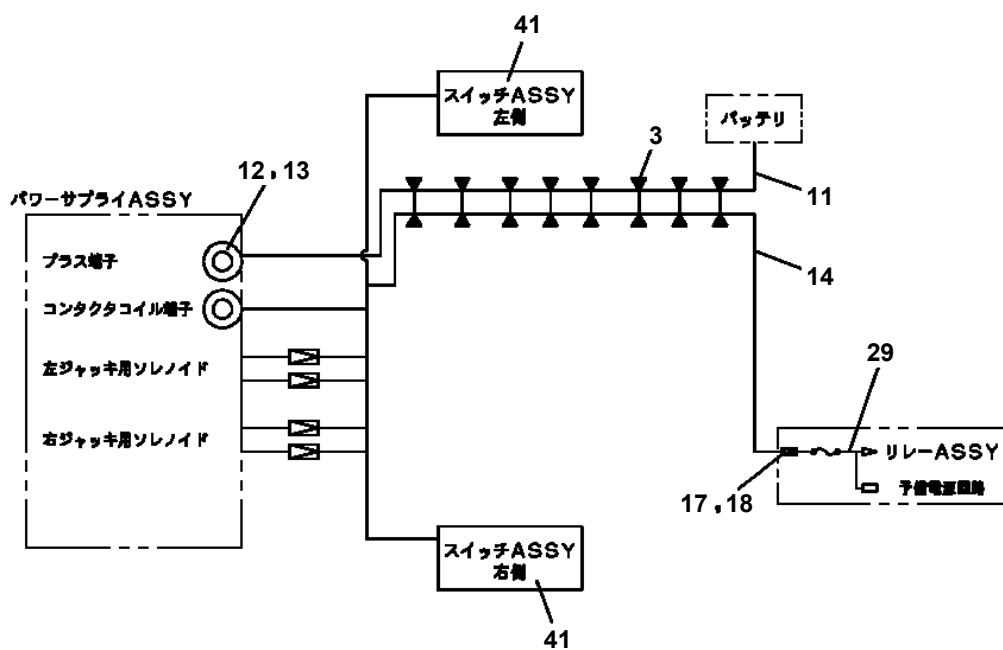
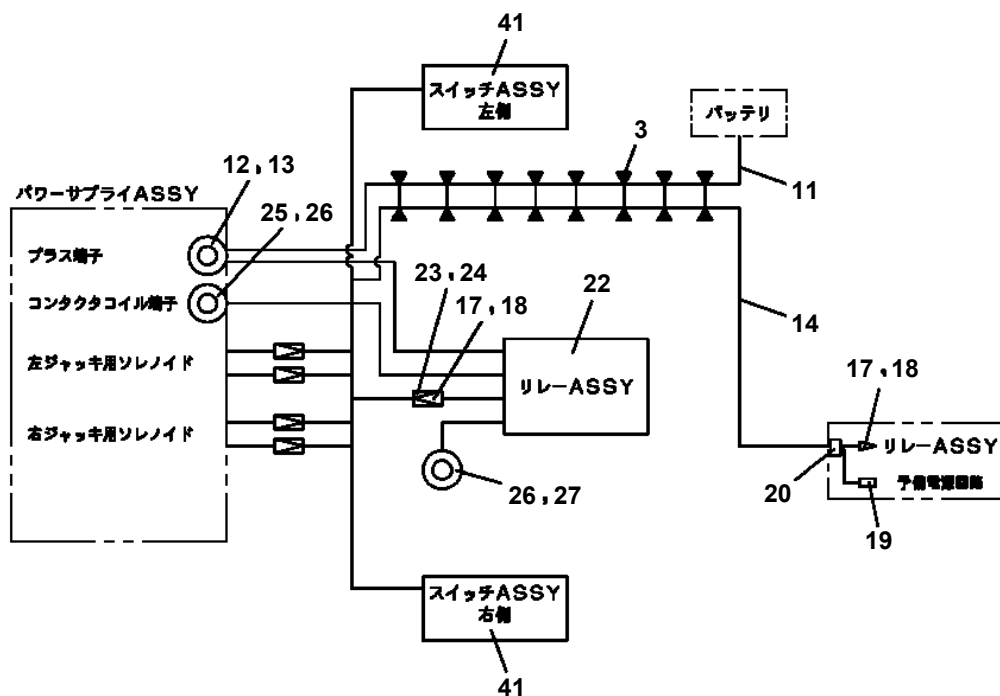

ハーネス経路

TM-ZX500 41050601274A FRAME
PE5021243-00 ELEC.ASSY (MAGNETIC DRUM ROTATION,PLUG)

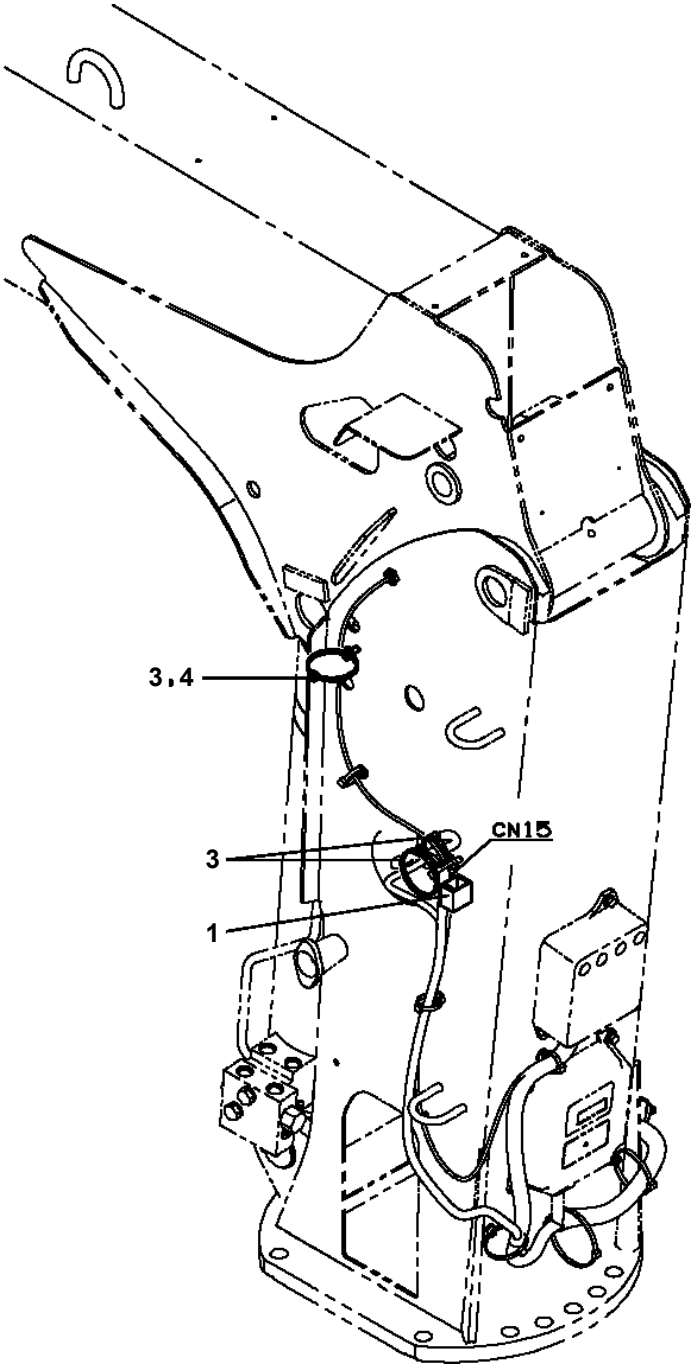

TM-ZX500 41050601274A FRAME
PE5021335-00 ELEC.ASSY (POST)

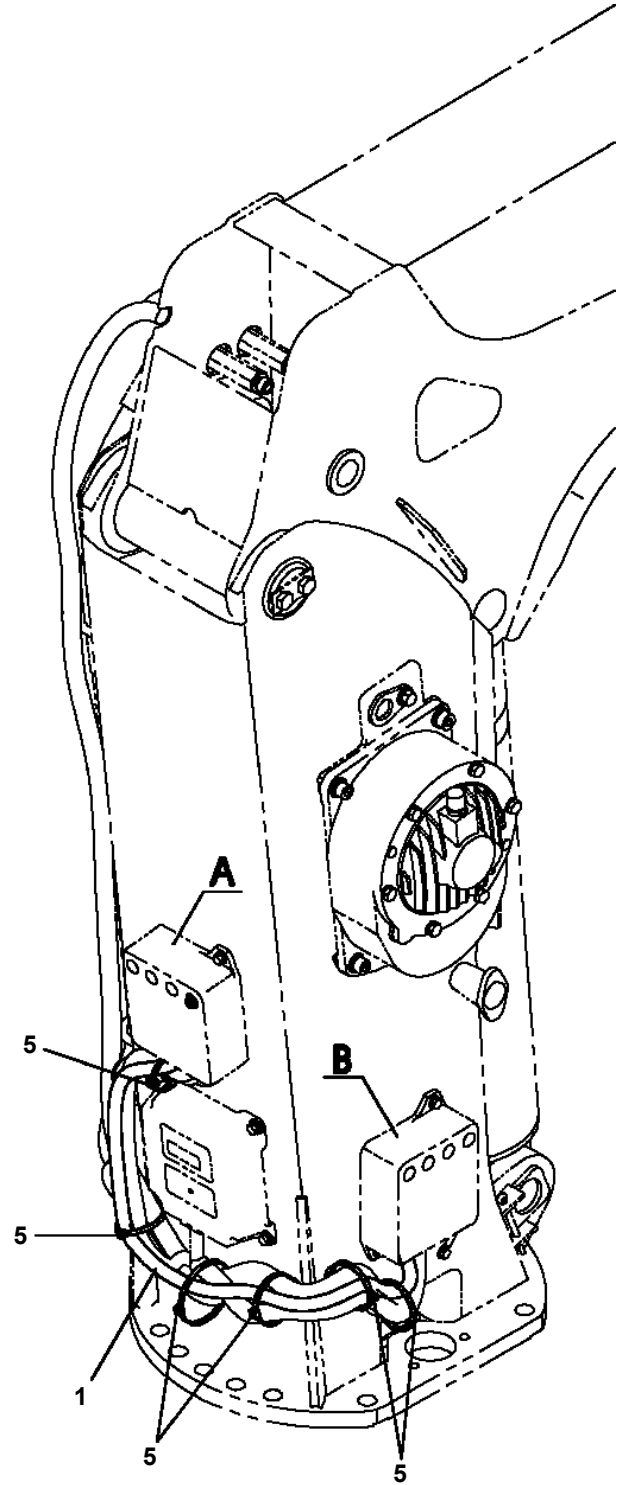
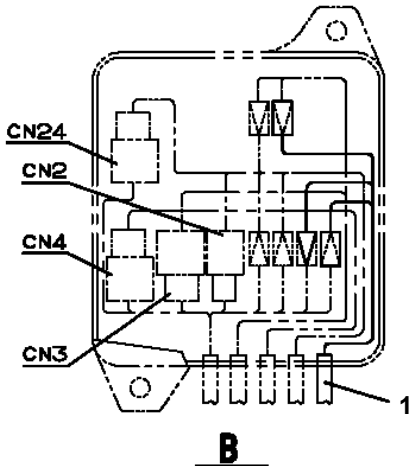
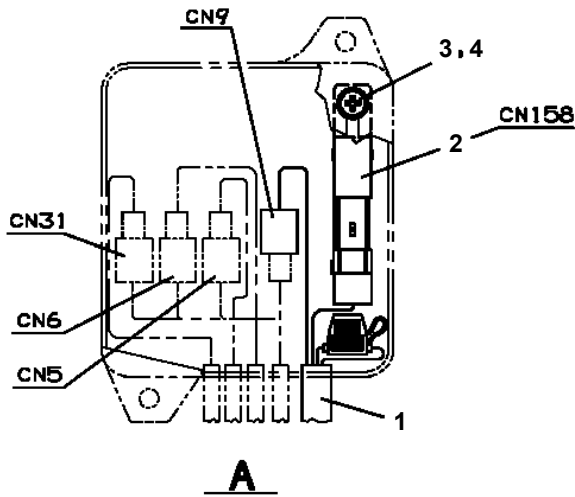

TM-ZX500 41050601274A FRAME
PE5021414-00 ELEC.ASSY

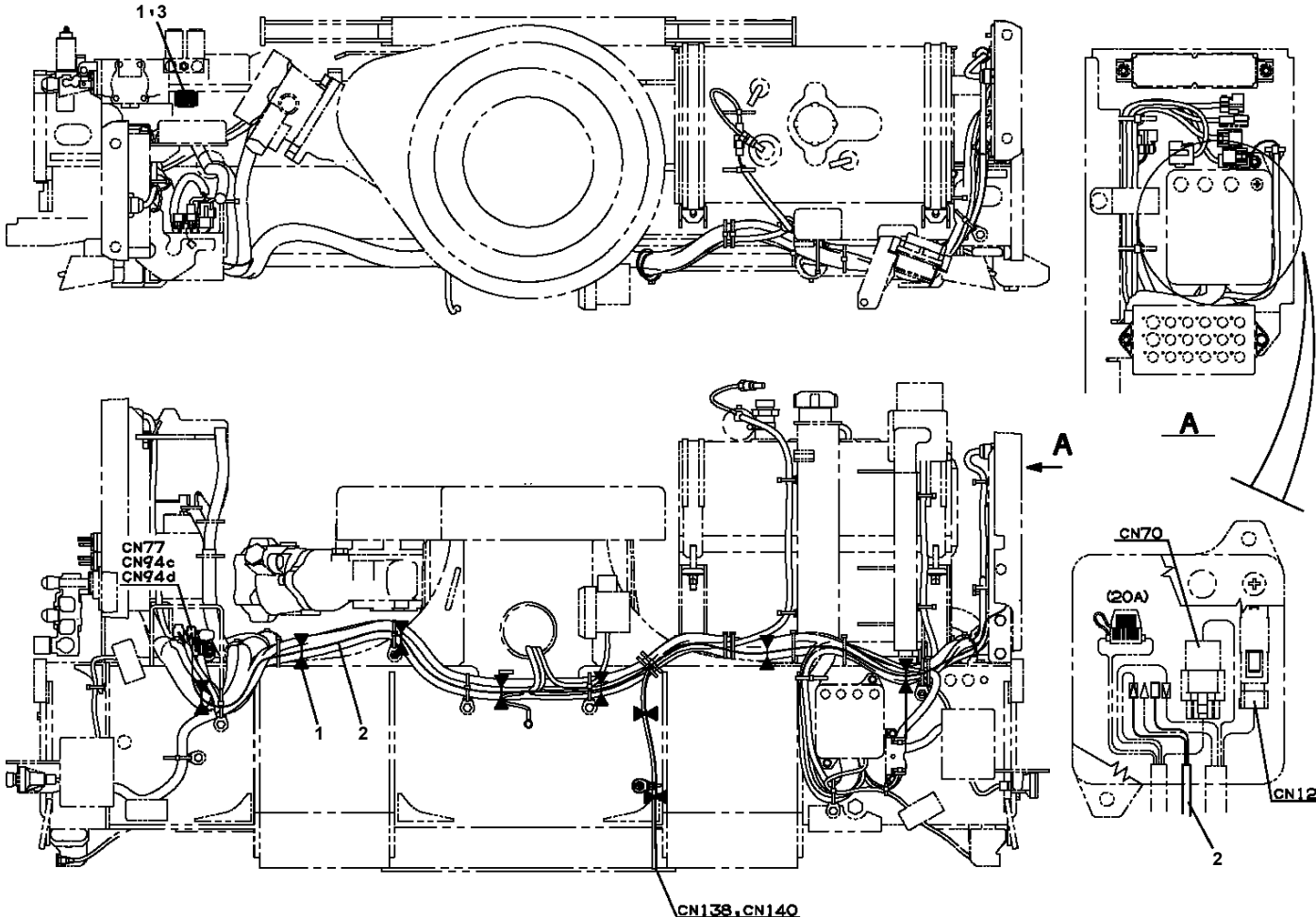

TM-ZX500 41050601274A FRAME
PF1020007-00 DRUM,WINCH (HARTYS)

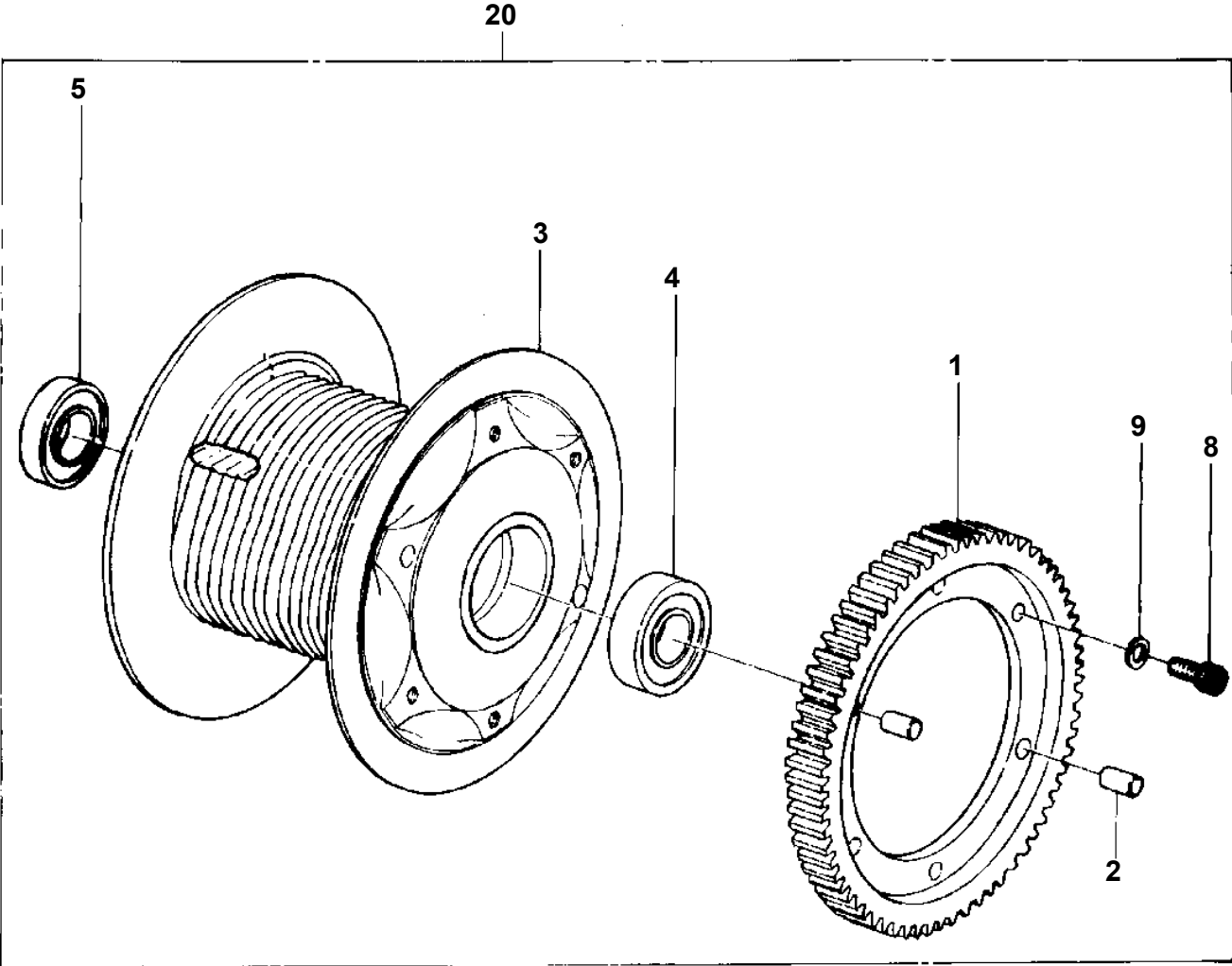

TM-ZX500 41050601274A FRAME
PF1050274-00 HOOK (10TON)

50

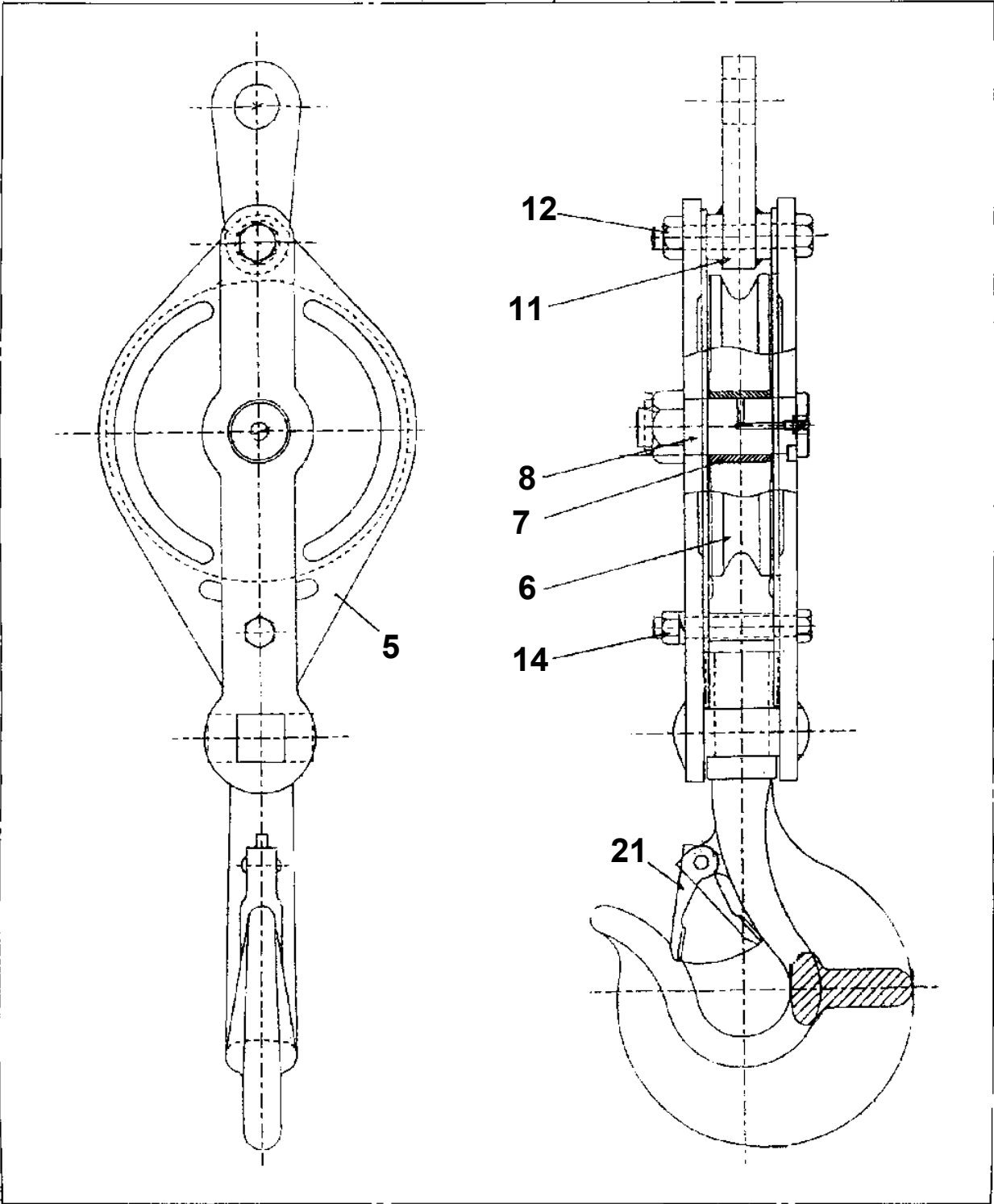

TM-ZX500 41050601274A FRAME
PF1050342-02 HOOK (SELF, 3TONX2-PART LINE)

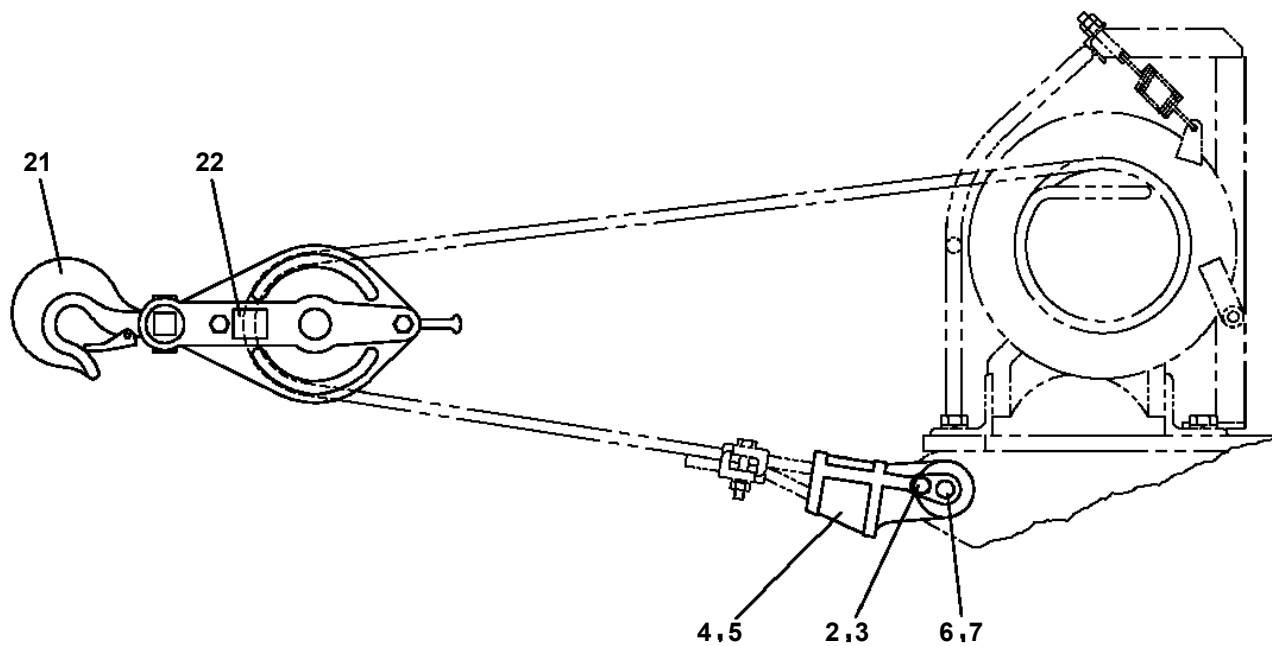

22
引込
5.0t
S14-280-11100

TM-ZX500 41050601274A FRAME
PF1400322-00 MOUNT,WINCH (3T SELF)

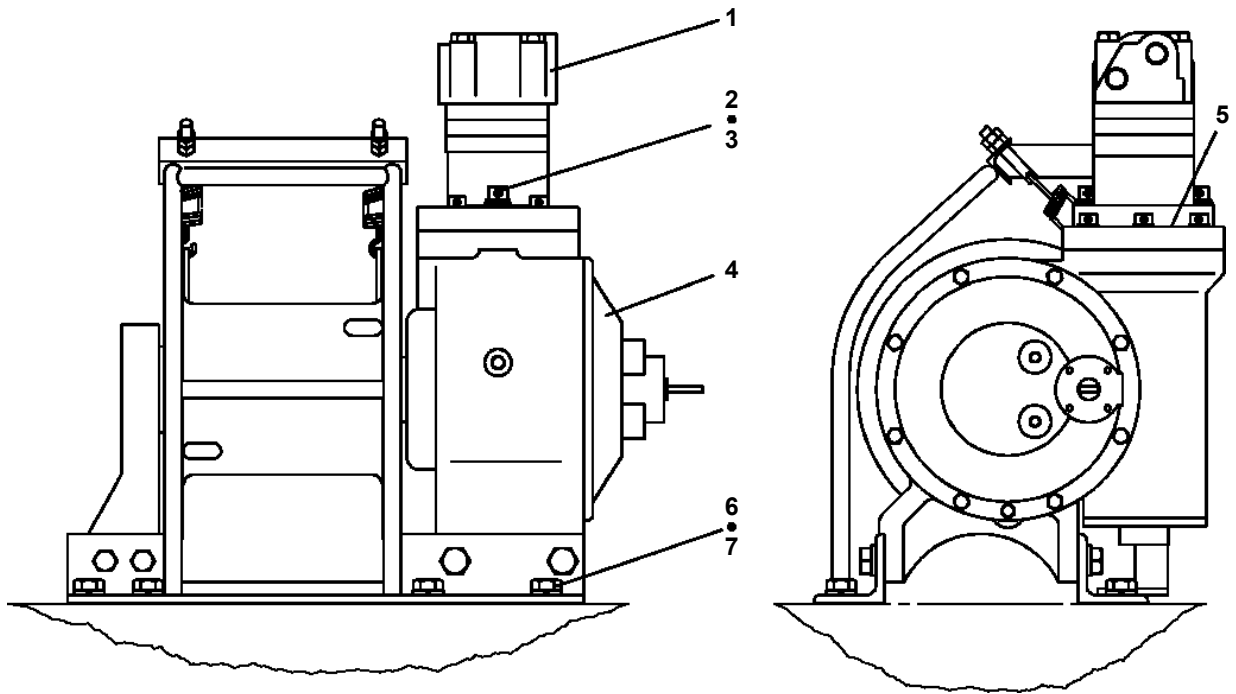

TM-ZX500 41050601274A FRAME

Pos No.	Parts No	Parts Name	Qty	Unit	Technical Data	Serial No (Start)	Serial No (End)	Remarks	Pages
1	90203201400	NUT	2		M14				
2	37000574030	PLATE	1						
3	31477171100	GUIDE ASSY	1						
4	90101214020	BOLT	1		M14X20				
5	37000532240	PLATE	1						
6	31471731600	PIN	1						
7	90101214035	BOLT	1		M14X35				
8	31477171500	SUPPORT	2						
9	90302041401	WASHER,SPRING	1		14				
10	37000303800	SPACER	1		L=48				
11	37000304020	SPACER	1		L=6				
32	80620210160	PIN,SNAP	1						
33	31471731200	PIN	1						
34	37001102960	ROLLER ASSY	1						
35	80601110150	RING,RITAINING	2		15				
36	80804035050	BUSH	2						
37	31471731500	SHEAVE ASSY	2						
38	80601110200	RING,RITAINING	2		S20				
52	80516006004	BEARING,BALL	2						
53	80602110420	RING,RITAINING	2		R42				
61	31477171201	GUIDE	1						
72	80516006002	BEARING,BALL	2						

TM-ZX500 41050601274A FRAME

Pos No.	Parts No	Parts Name	Qty	Unit	Technical Data	Serial No (Start)	Serial No (End)	Remarks	Pages
100	31478092100	HARNESS	1						

TM-ZX500 41050601274A FRAME

Pos No.	Parts No	Parts Name	Qty	Unit	Technical Data	Serial No (Start)	Serial No (End)	Remarks	Pages
100	31505222202	HARNESS	1						

TM-ZX500 41050601274A FRAME

Pos No.	Parts No	Parts Name	Qty	Unit	Technical Data	Serial No (Start)	Serial No (End)	Remarks	Pages
10	31506121100	HARNESS	1						

TM-ZX500 41050601274A FRAME

Pos No.	Parts No	Parts Name	Qty	Unit	Technical Data	Serial No (Start)	Serial No (End)	Rema
2	(*****)	NAME PLATE ASSY	1					
11	36090230000	HOOK (1-PART LINE ,OPTION)	1					
12	(*****)	NAME PLATE ASSY (0.49T)	1					

TM-ZX500 41050601274A FRAME

Pos No.	Parts No	Parts Name	Qty	Unit	Technical Data	Serial No (Start)	Serial No (End)	Remarks
6	36611675010	SPRING	2					
7	36611675020	O-RING	2		P12			
8	36611675030	O-RING	2		P24			
100	36611670000	VALVE,FLOW CONTROL	1					

TM-ZX500 41050601274A FRAME

Pos No.	Parts No	Parts Name	Qty	Unit	Technical Data	Serial No (Start)	Serial No (End)	Remarks
4	36671025020	GASKET	1					
10	36672590000	FILTER,OIL (CARTRIDGE)	1					

TM-ZX500 41050601274A FRAME

Pos No.	Parts No	Parts Name	Qty	Unit	Technical Data	Serial No (Start)	Serial No (End)	Remarks
1	36671635010	JOINT,SELF SEALING	1					
2	36671635020	JOINT,SELF SEALING	1					
10	36671630000	JOINT ASSY,SELF SEAL	1					

TM-ZX500 41050601274A FRAME

Pos No.	Parts No	Parts Name	Qty	Unit	Technical Data	Serial No (Start)	Serial No (End)	Remarks	Pages
1	31701750100	SUPPORT	1						
2	37000147840	PIN	1						
3	80620210050	PIN,SNAP	1						
4	37000165020	PIN	1						
5	80136340020	PIN,SPLIT	1		4X20				
7	31701580801	LEVER	1						
8	31322224200	PLATE	1		L=1				
9	31323330100	KNOB (BLACK)	1						

TM-ZX500 41050601274A FRAME

Pos No.	Parts No	Parts Name	Qty	Unit	Technical Data	Serial No (Start)	Serial No (End)	Remarks	Pa
2	(*****)	ELEC.ASSY (POST)	1						000
3	(*****)	ELEC.ASSY (POST/LED)	1						000

TM-ZX500 41050601274A FRAME

Pos No.	Parts No	Parts Name	Qty	Unit	Technical Data	Serial No (Start)	Serial No (End)	Remarks	Pages
1	31616277100	SUPPORT	1						
2	31616277200	SUPPORT	1						
3	91850700101	CLAMP	2		L=208				
4	91810130240	FASTENER	2						
5	91810130250	FASTENER	13						

TM-ZX500 41050601274A FRAME

Pos No.	Parts No	Parts Name	Qty	Unit	Technical Data	Serial No
1	31595761000	NAME PLATE ASSY (KNOB:U-LAYOUT)	1			
4	(*****)	NAME PLATE ASSY (TANK)	1			
5	(*****)	PLATE ASSY,NAME (HOOK)	1			
6	(*****)	NAME PLATE ASSY (OUTRIGGER CAUTION PLATE ETC.)	1			
7	(*****)	NAME PLATE ASSY (PERIODICAL VOLUNTARY INSPECTION)	1			
8	31595753000	NAME PLATE ASSY (KNOB,SL JACK)	1			

CLICK HERE TO **DOWNLOAD** THE COMPLETE MANUAL

- Thank you very much for reading the preview of the manual.
- You can download the complete manual from: www.heydownloads.com by clicking the link below



- Please note: If there is no response to CLICKING the link, please download this PDF first and then click on it.

CLICK HERE TO **DOWNLOAD** THE COMPLETE MANUAL

TM-ZX500 41050601274A FRAME

Pos No.	Parts No	Parts Name	Qty	Unit	Technical Data	Serial No (Start)	Serial No (End)	Remarks	Pages
1	31326430110	PLATE,NAME	1						

TM-ZX500 41050601274A FRAME

Pos No.	Parts No	Parts Name	Qty	Unit	Technical Data	Serial No (Start)	Serial No (End)	Remarks	Pages
1	37002241820	PLATE,NAME	2						

TM-ZX500 41050601274A FRAME

Pos No.	Parts No	Parts Name	Qty	Unit	Technical Data	Serial No (Start)	Serial No (End)	Remarks
1	31506446100	PLATE,NAME	2					
2	31506446200	PLATE,NAME	1					
3	31611823200	PLATE,CAUTION	2					
4	31506446400	PLATE,NAME	1					
5	31393180100	REFLECTOR (RED)	4					
6	31615754100	PLATE,NAME (BLUE)	4					
7	37002213970	PLATE,NAME (MARKING)	2					
8	37002240210	PLATE,CAUTION	2					
9	37002240110	PLATE,CAUTION	2					

TM-ZX500 41050601274A FRAME

Pos No.	Parts No	Parts Name	Qty	Unit	Technical Data	Serial No (Start)	Serial No (End)
100	31595753000	NAME PLATE ASSY (KNOB,SL JACK)	1				

TM-ZX500 41050601274A FRAME
PO1014946-01 PLATE ASSY,NAME (POST)

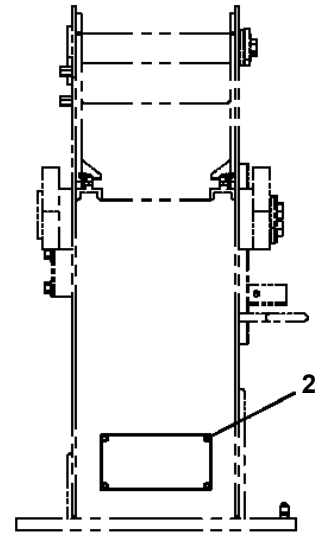
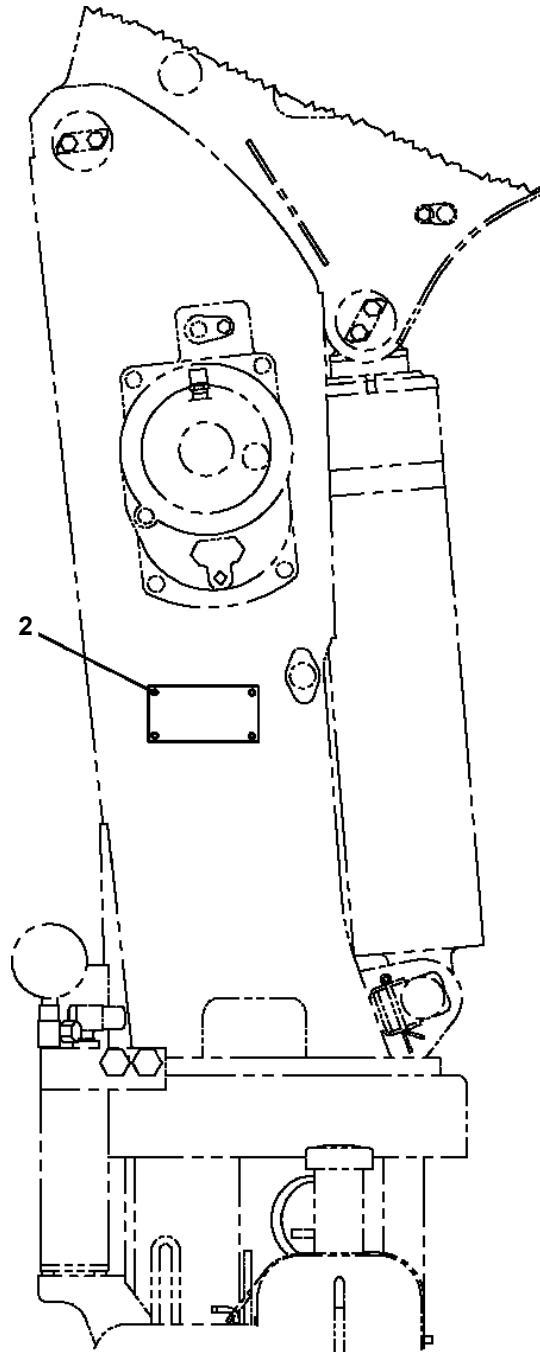

ZS220
(ポスト前面)

TM-ZX500 41050601274A FRAME
PO5080301-00 OPE.ASSY,CONT.VALVE (ELEVATING,WINCH,TELESCOPING/TDN)

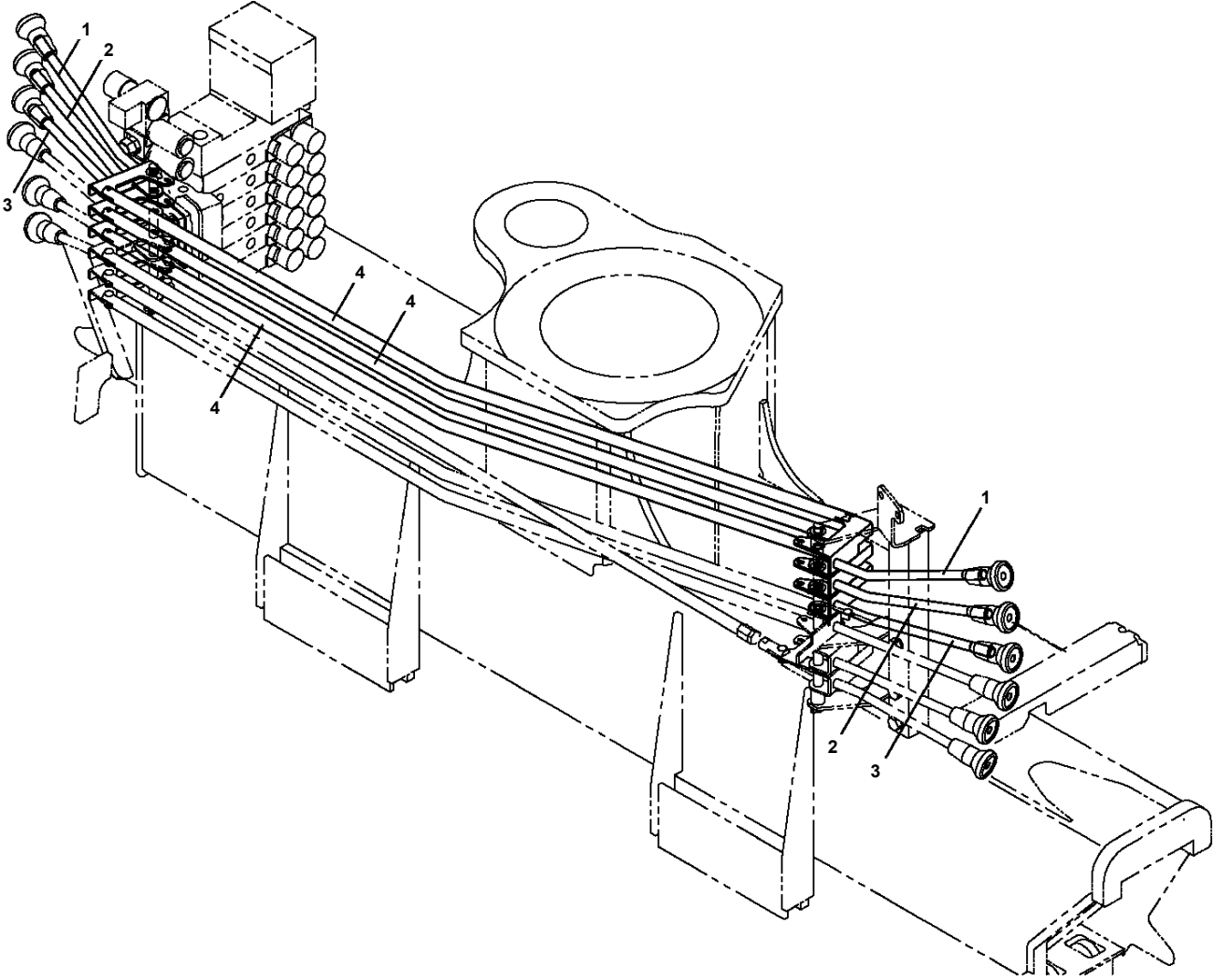

**TM-ZX500 41050601274A FRAME
PO5270402-00 OUTRIGGER ASSY**

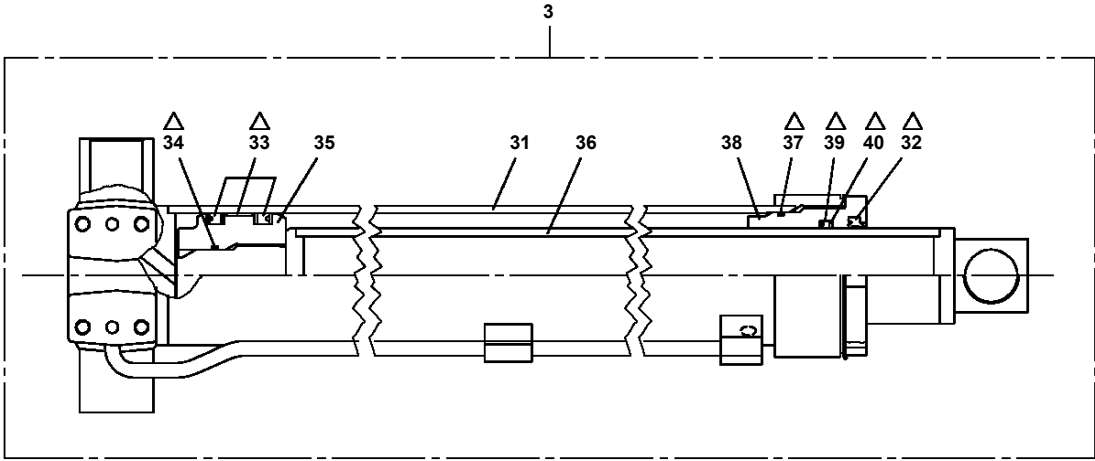
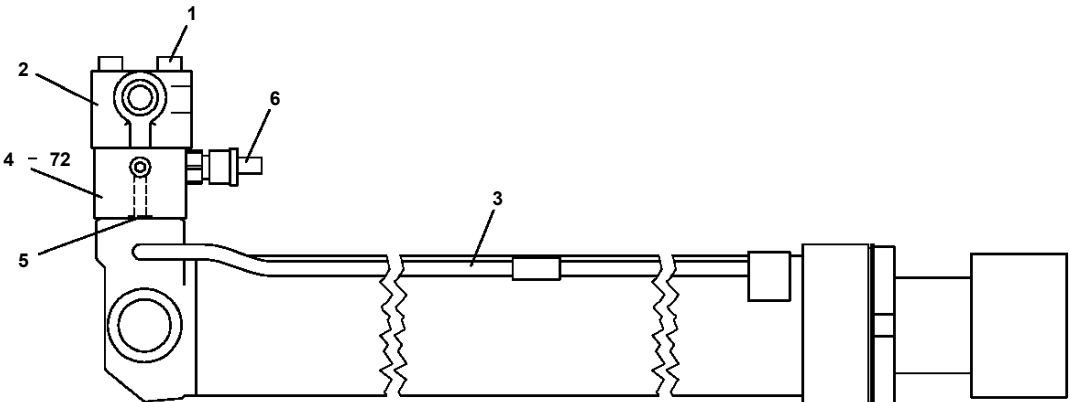

△:PACKING SET KEY NO.60 (KEY NO.32,33,34,37,39,40)

**TM-ZX500 41050601274A FRAME
PO5270462-00 OUTRIGGER ASSY (RIGHT)**

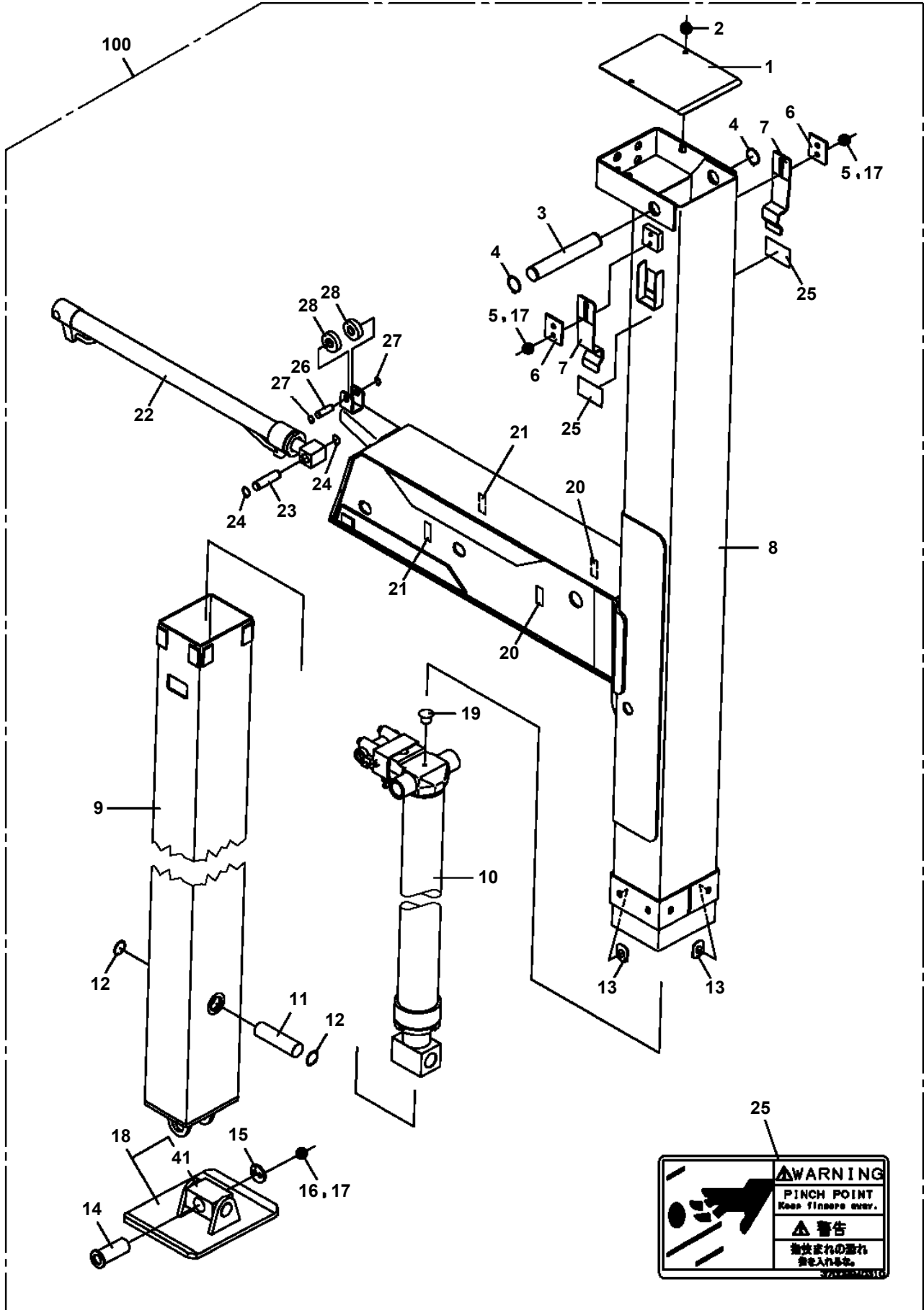

25

	▲WARNING
	PINCH POINT Keep fingers away.
	▲警告 指先の押し入れ を避けてください。

TM-ZX500 41050601274A FRAME
PO5270470-00 OUTRIGGER ASSY (L=60,ST=1400/REVERSE L-TYPE)

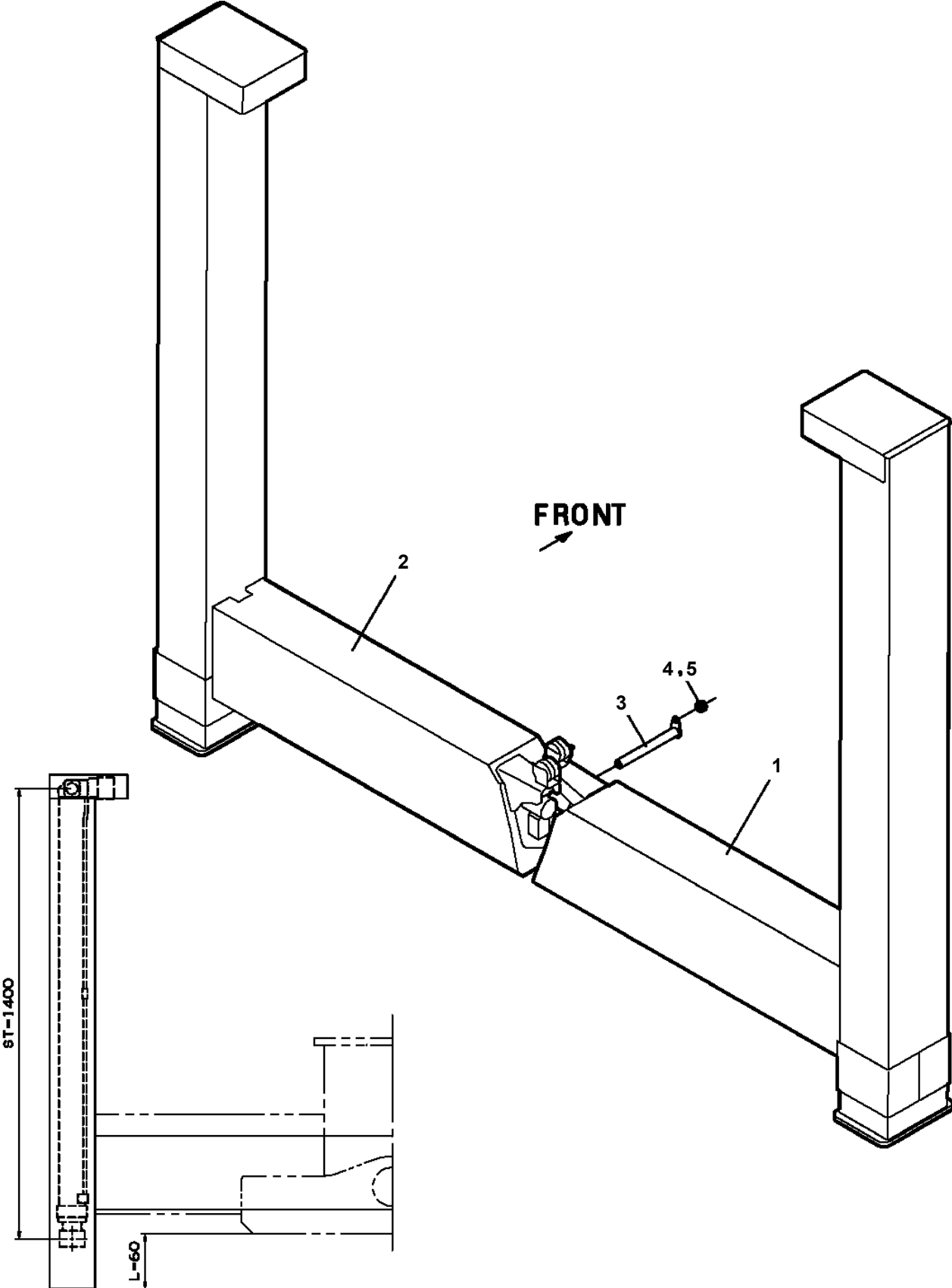

TM-ZX500 41050601274A FRAME
PP5150037-00 PARTS ASSY,RADIO CONTROLLER

ハーツASSY, ラジコン
PARTS ASSY,RADIO CONTROLLER

符号	日本語名称	英語名称	備考
2	アンテナユニット	ANTENNA UNIT	通信ユニット (RCS-FR3N)
3	ホックス, オペレーション	BOX, OPERATION	LCD送信機 (RCS-FT3N)
5	ハイゼンASSY	ELEC. ASSY	通信ユニット
6	ハック	BAG	
9	コントロールユニット	CONTROL UNIT	制御器 (RCS-FC3)

適用製造番号によっては取り付けがないものもあります。

MACHINES OF SOME SERIAL NO. ARE NOT EQUIPPED WITH THESE PARTS.

TM-ZX500 41050601274A FRAME
PP5200785-00 PERFORMANCE DATA (B)

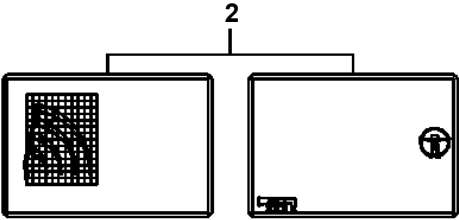

携帯用

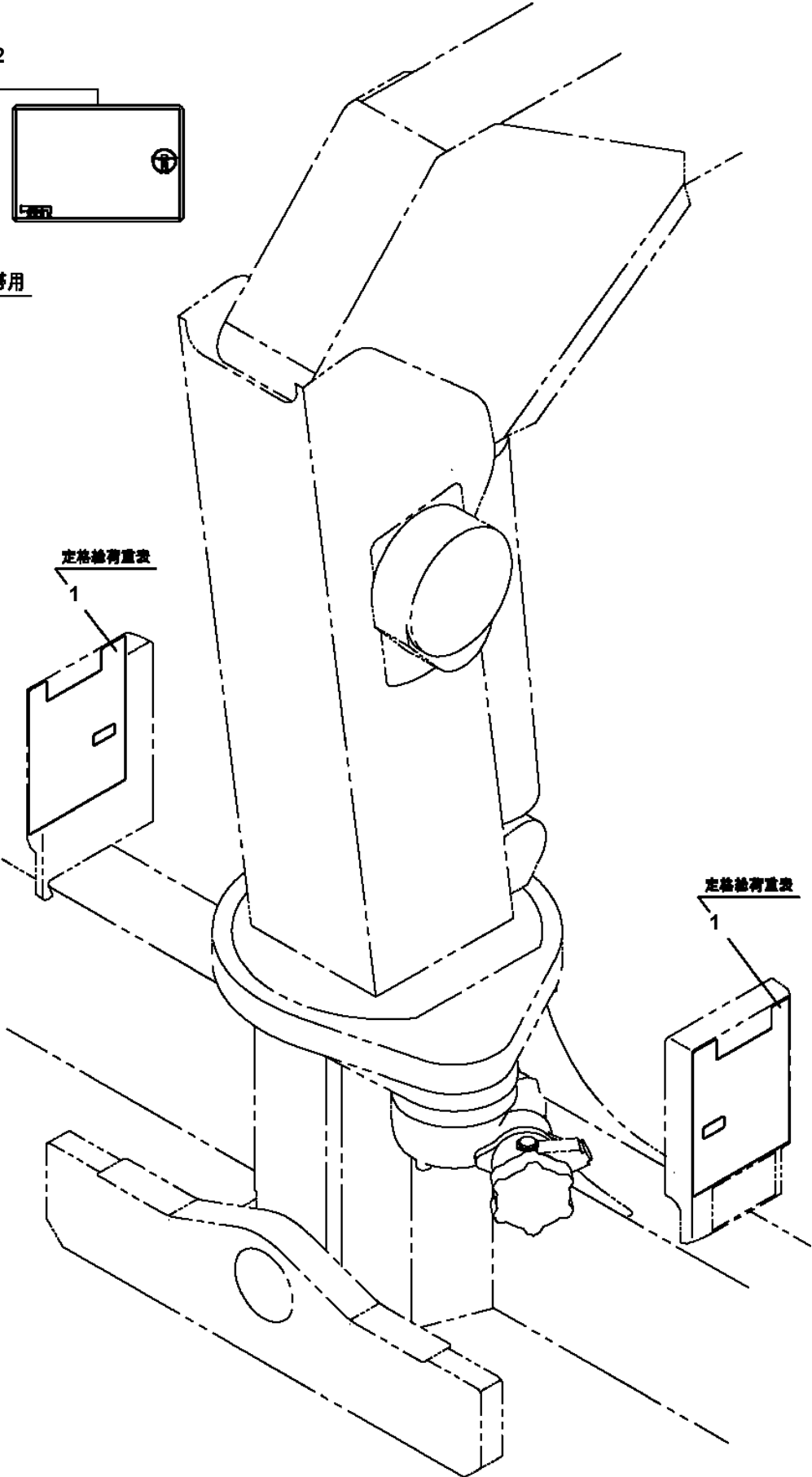

TM-ZX500 41050601274A FRAME
PP6010511-00 PIPING ASSY (UPPER)

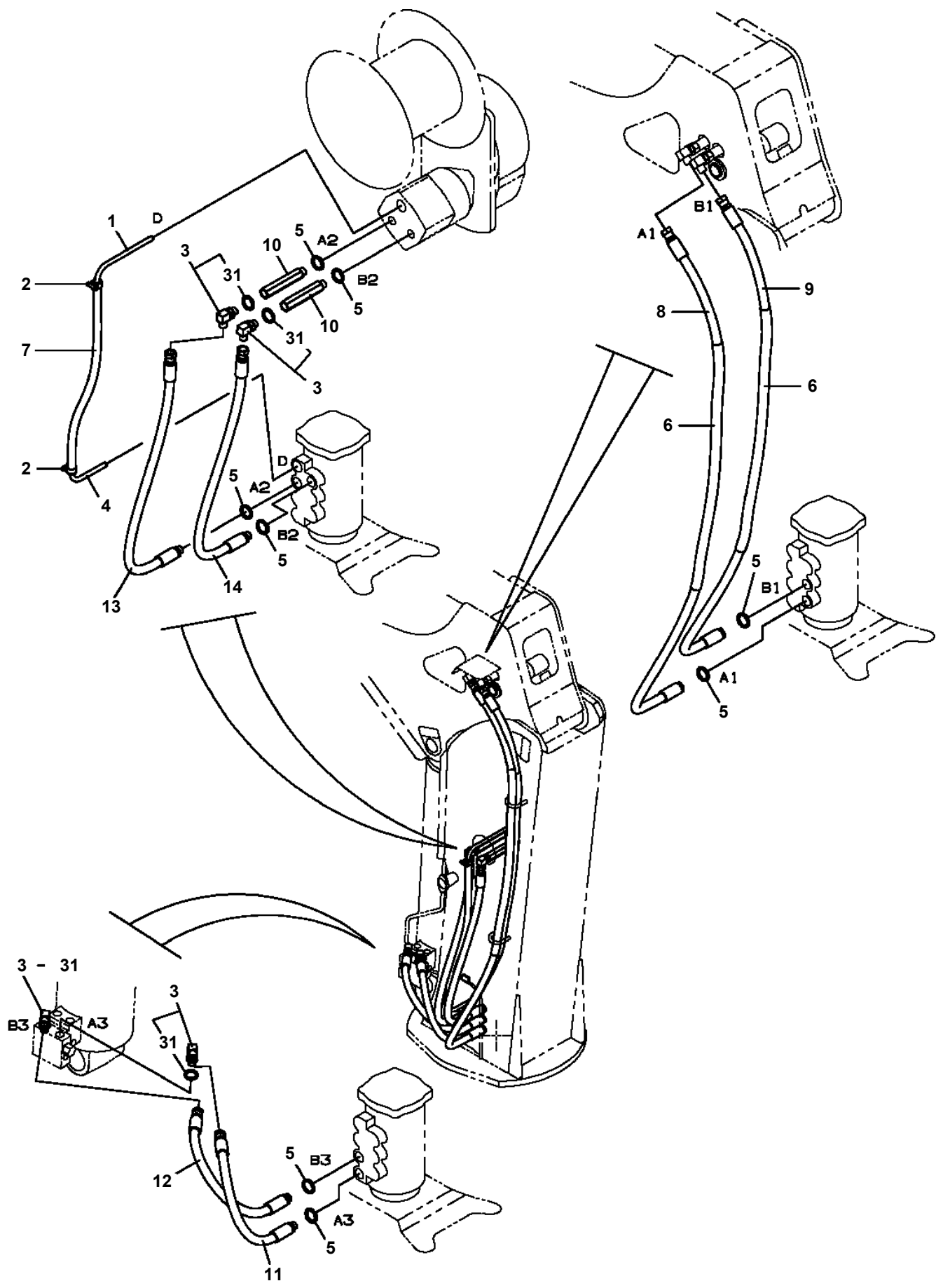

TM-ZX500 41050601274A FRAME

Pos No.	Parts No	Parts Name	Qty	Unit	Technical Data	Serial No (Start)	Serial No (End)	Remarks	Pages
1	80430450250	JOINT	1		L R1/8-G1/8				
2	80430410250	JOINT	1		S R1/8-G1/8				
3	82100002006	CLAMP	2		WR10				
4	90280200600	NUT,FLANGE	2		M6				
5	37002474140	HOSE	1		L=950				
6	91810130250	FASTENER	1						

TM-ZX500 41050601274A FRAME

Pos No.	Parts No	Parts Name	Qty	Unit	Technical Data	Serial No (Start)	Serial No (End)	Remarks
1	37002305850	BEARING,SWING	1					
2	37001507220	BOLT	25		M20X85			
3	37001510290	BOLT	10		M20X55			
4	90171116045	BOLT	5		M16X45			
5	90303501601	WASHER,PLAIN	5		16			
6	36081760000	REDUCER,SWING SPEED	1					
7	91001208500	O-RING	1		1A G85			
8	90172112035	BOLT,HEXAGON SOCKET	2		M12X35			
9	90302041201	WASHER,SPRING	2		12			
10	36663950000	MOTOR,HYDRAULIC	1					
11	37001507580	WASHER,PLAIN	31					
12	82456101000	NIPPLE,GREASE	2		A-PT1/8			

TM-ZX500 41050601274A FRAME

Pos No.	Parts No	Parts Name	Qty	Unit	Technical Data	Serial No (Start)	Serial No (End)	Re
1	(*****)	PARTS ASSY,RADIO CONTROLLER	1					

TM-ZX500 41050601274A FRAME

Pos No.	Parts No	Parts Name	Qty	Unit	Technical Data	Serial No (Start)	Serial No (End)	Remarks
7	91001000800	O-RING	1		S8			
8	36646865190	PISTON	1					
9	91001102000	O-RING	1		1A P20			
10	36648365110	FLANGE	1					
11	91001002240	O-RING	1		S22.4			
12	91650001400	SCRAPER	1					
13	36645495210	SEAT,SPRING (RETURN)	2					
14	36646865200	SPOOL (SUB)	1					
15	36645845060	SPRING (RETURN)	1					
16	36633365070	ADAPTER	1					
17	36646865210	SPACER	1					
18	36640625550	PLATE (D)	1					
19	36645615250	C-BOLT	2		M5X25			
20	36633365100	SEAL,OIL	1					
21	36633365060	PLATE (B)	1					
22	36645615260	C-BOLT	2		M5X8			
23	12635101360	SPOOL	1					
24	12635101190	SPRING	1					
25	36633365090	CAP (CHECK VALVE)	1					
27	91001002200	O-RING	2		S22			
29	36740745140	SCREW,MACHINE	4		M4X12			
30	91001100600	O-RING	5		1A P6			
31	91002905500	O-RING	1		1B G55			
51	36740855030	VALVE,SOLENOID (KIT)	2					
100	36743410050	VALVE,CONTROL	1					

**TM-ZX500 41050601274A FRAME
PY2000300-00 OPTION UNIT,2 (COMMON)**

オフ ションユニット,2 (キョウツウ)
OPTION UNIT,2 (COMMON)

符号	日本語名称	英語名称	備考
29	ハイゼンASSY	ELEC. ASSY	作業灯2灯取付用ハーネス ホースト部(LED)+フーム部(LED又はハロゲン)に適合
30	ハイゼンASSY	ELEC. ASSY	警報仕様(定格再直角指示装置)
31	ハイゼンASSY	ELEC. ASSY	停止仕様(定格再直制限装置)
32	ハイゼンASSY	ELEC. ASSY	送信機(FT3)置き忘れ警報装置
33	ネームプレートASSY	NAME PLATE ASSY	フーム・シ ッキインターロック装置付
34	ネームプレートASSY	NAME PLATE ASSY	フーム格納忘れ警報装置付
35	ネームプレートASSY	NAME PLATE ASSY	アウトリカ格納忘れ警報装置付
36	ネームプレートASSY	NAME PLATE ASSY	フーム・アウトリカ格納忘れ警報装置付
37	ネームプレートASSY	NAME PLATE ASSY	高さ制限装置付
38	ネームプレートASSY	NAME PLATE ASSY	NETIS銘板 SK-110003-VE Sサイズ

適用製造番号によっては取り付けがないものもあります。

MACHINES OF SOME SERIAL NO. ARE NOT EQUIPPED WITH THESE PARTS.

TM-ZX500 41050601274A FRAME
PZ0000000-00 ELEC.ASSY (UPPER/COMMON)

販売部品 検討中につき、イラストはありません。

**Parts for sale : Under consideration now.
Therefore not illustrated.**

TM-ZX500 41050601274A FRAME
PZ0000000-00 PARTS ASSY,REMOTE CONTROL

販売部品 検討中につき、イラストはありません。

**Parts for sale : Under consideration now.
Therefore not illustrated.**

TM-ZX500 41050601274A FRAME
PZ0000000-00 OUTRIGGER ASSY (L=590,ST=1400)

販売部品 検討中につき、イラストはありません。

**Parts for sale : Under consideration now.
Therefore not illustrated.**

TM-ZX500 41050601274A FRAME
PZ0000000-00 OUTRIGGER ASSY (L=750,ST=1400)

販売部品 検討中につき、イラストはありません。

**Parts for sale : Under consideration now.
Therefore not illustrated.**

**TM-ZX500 41050601274A FRAME
PZ0000000-00 PIPING ASSY,OUTRIGGER (REVERSE L-TYPE)**

販売部品 検討中につき、イラストはありません。

**Parts for sale : Under consideration now.
Therefore not illustrated.**

**TM-ZX500 41050601274A FRAME
PZ0000000-00 PIPING ASSY**

販売部品 検討中につき、イラストはありません。

**Parts for sale : Under consideration now.
Therefore not illustrated.**

**TM-ZX500 41050601274A FRAME
PZ0000000-00 MOUNT ASSY (ACCELERATOR)**

販売部品 検討中につき、イラストはありません。

**Parts for sale : Under consideration now.
Therefore not illustrated.**

**TM-ZX500 41050601274A FRAME
PZ0000000-00 PIPING ASSY (CRANE)**

販売部品 検討中につき、イラストはありません。

**Parts for sale : Under consideration now.
Therefore not illustrated.**

**TM-ZX500 41050601274A FRAME
PZ0000000-00 HARNESS**

販売部品 検討中につき、イラストはありません。

**Parts for sale : Under consideration now.
Therefore not illustrated.**

CLICK HERE TO **DOWNLOAD** THE COMPLETE MANUAL

- Thank you very much for reading the preview of the manual.
- You can download the complete manual from: www.heydownloads.com by clicking the link below



- Please note: If there is no response to CLICKING the link, please download this PDF first and then click on it.

CLICK HERE TO **DOWNLOAD** THE COMPLETE MANUAL