

TM-ZX500 41050601236A FRAME

PB0000386-00 SYSTEM (ZX500SL,DOMESTIC)

ASSEMBLY

CLICK HERE TO **DOWNLOAD** THE COMPLETE MANUAL

- Thank you very much for reading the preview of the manual.
- You can download the complete manual from: www.heydownloads.com by clicking the link below



- Please note: If there is no response to CLICKING the link, please download this PDF first and then click on it.

CLICK HERE TO **DOWNLOAD** THE COMPLETE MANUAL

TM-ZX500 41050601236A FRAME

Pos No.	Parts No	Parts Name	Qty	Unit	Technical Data	Serial No (Start)	Serial No (End)	Remark
81	36651645010	SEAL KIT	1					
100	36654340000	PUMP,HYDRAULIC (52CC:R)	1					

TM-ZX500 41050601236A FRAME

PB1380332-03 POWER SUPPLY (100V POWER SOURCE/1500W)

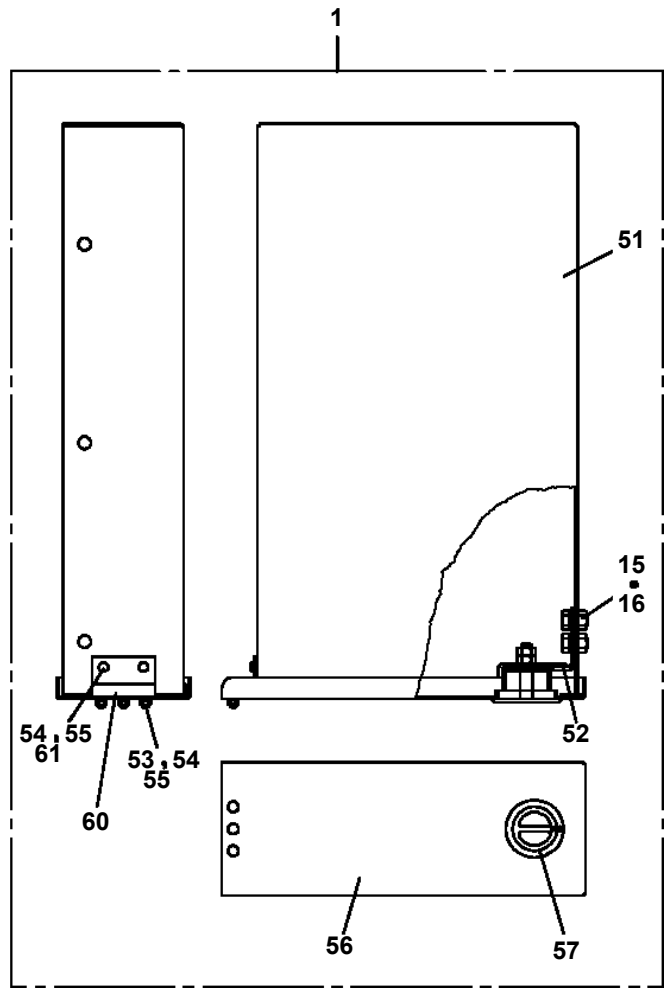
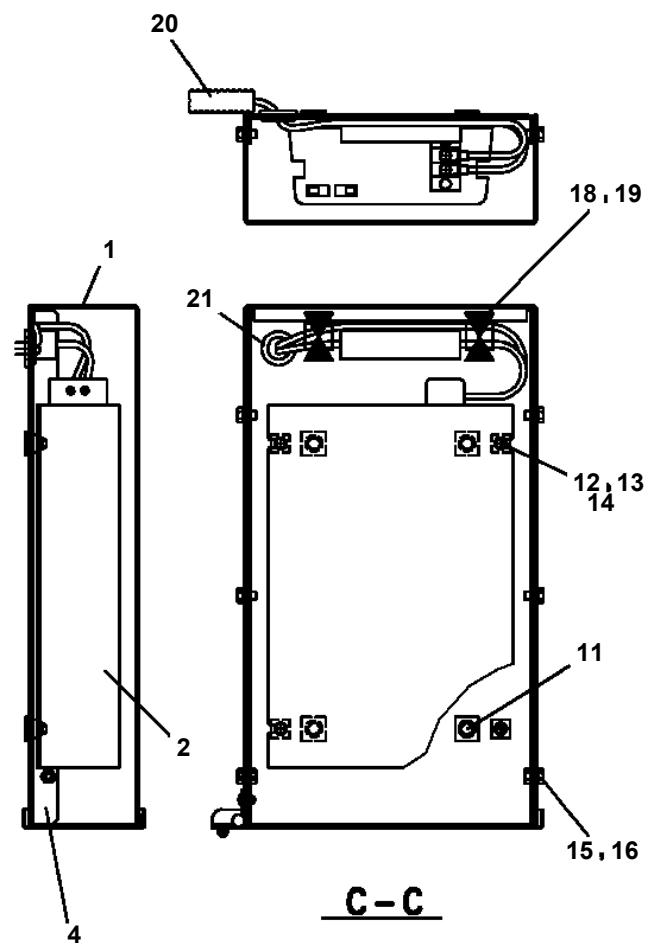
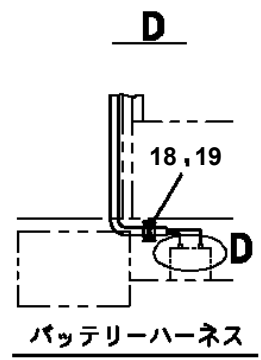
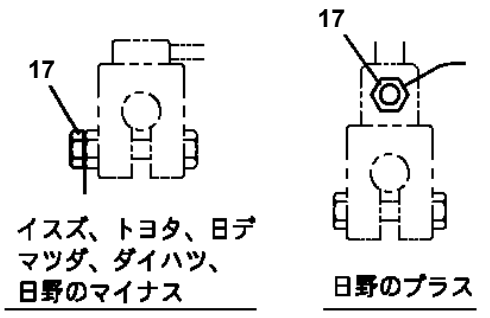
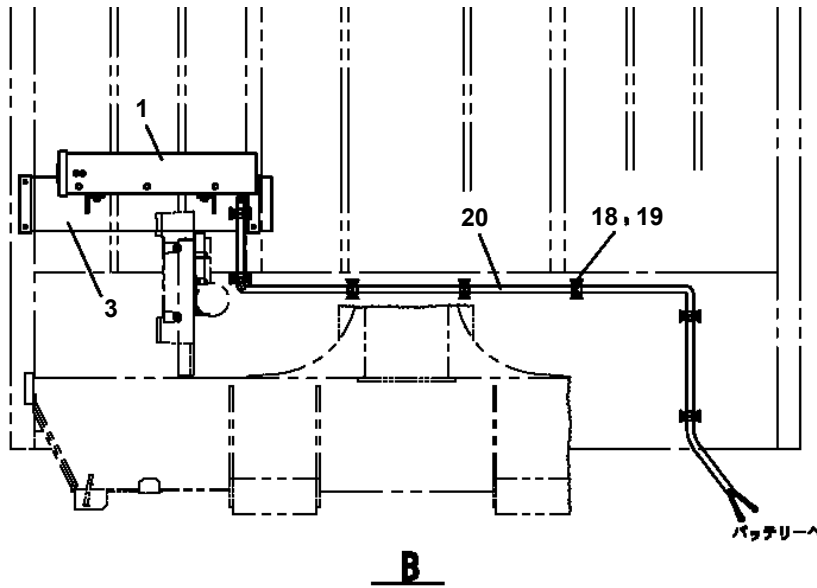

TM-ZX500 41050601236A FRAME
PB5110004-00 BLOCK (4 PIECE SET:PLATE,500X500,H=90)

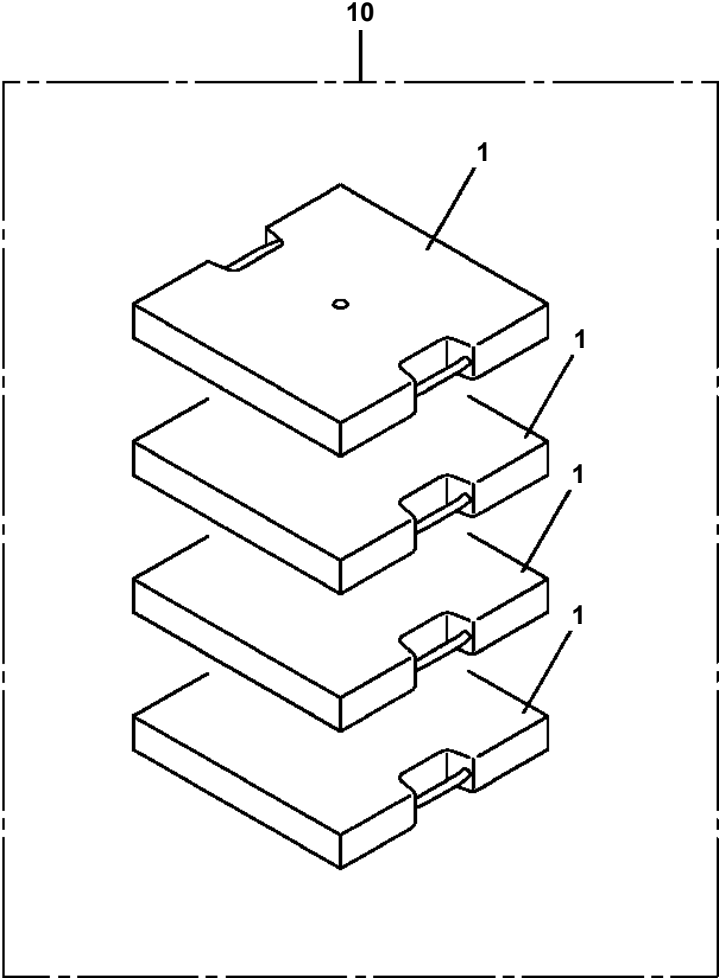

**TM-ZX500 41050601236A FRAME
PC1230023-03 PIPING,REAR JACK (ROTARY TYPE)**

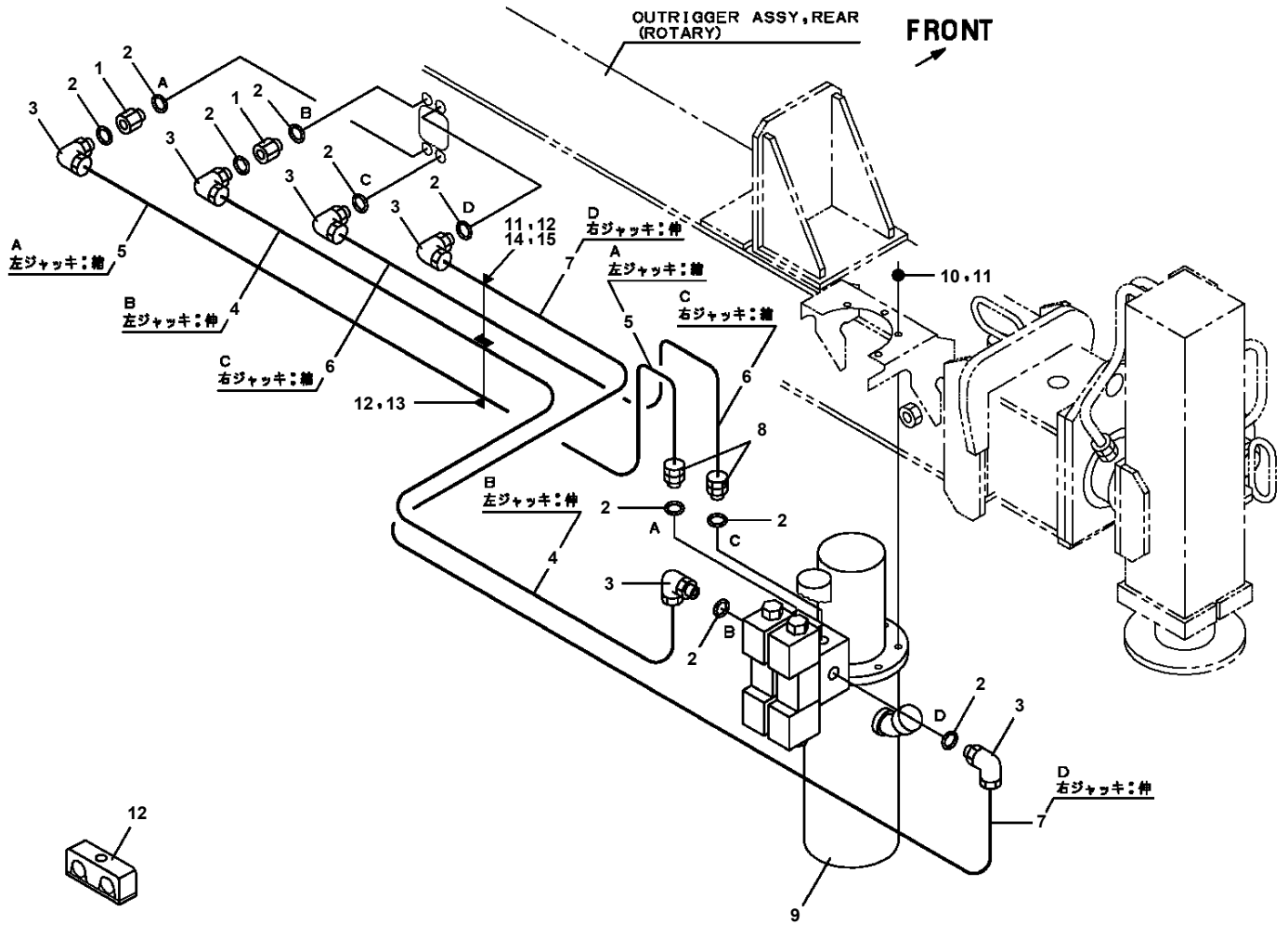

TM-ZX500 41050601236A FRAME
PC6380045-00 CYLINDER ASSY,EXTENSION (LEFT)

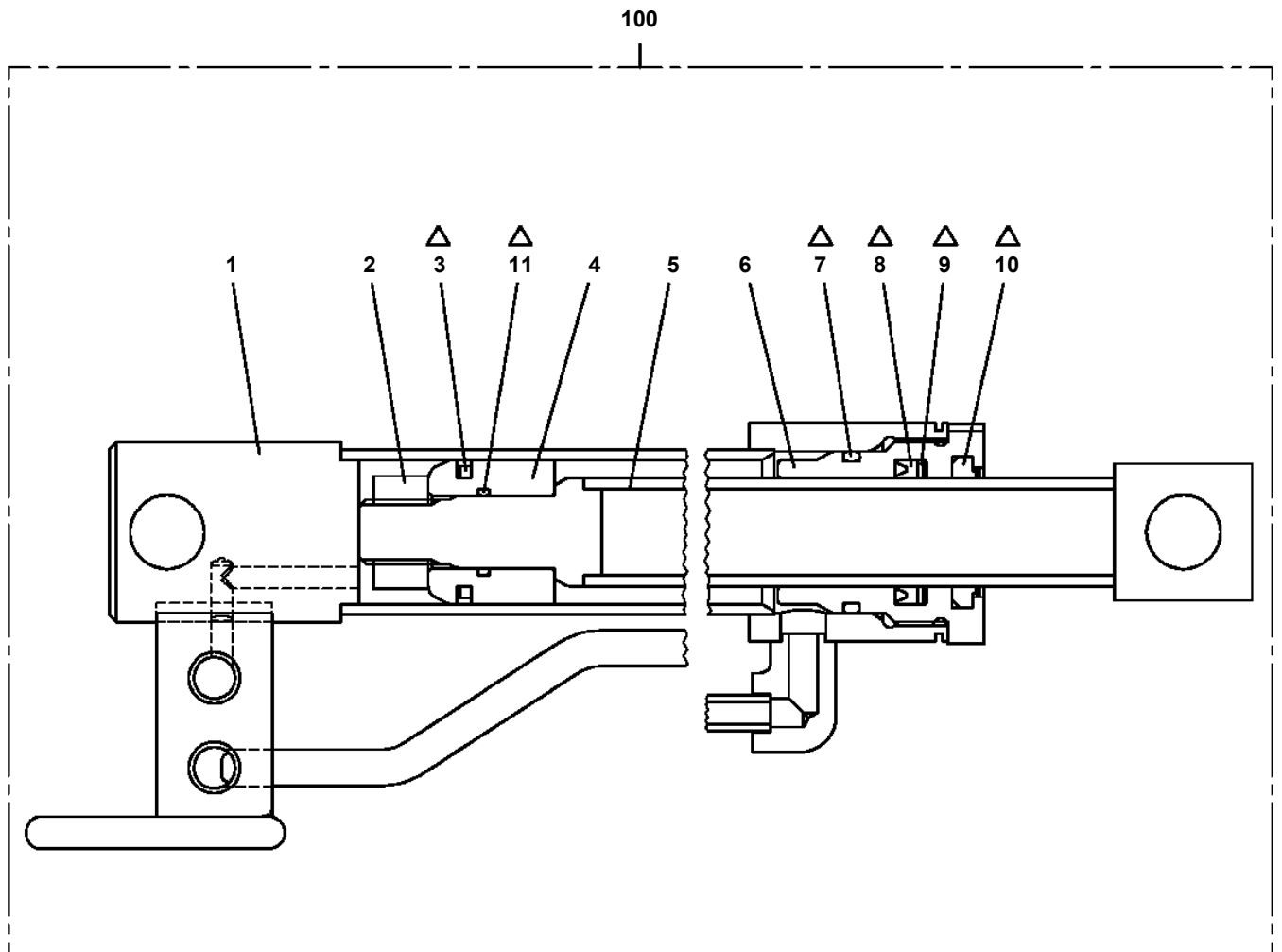

△:PACKING SET KEY NO. 40 (KEY NO. 3,7,8,9,10,11)

TM-ZX500 41050601236A FRAME

Pos No.	Parts No	Parts Name	Qty	Unit	Technical Data	Serial No (Start)	Serial No (End)
1	91850310405	CLAMP (BLACK)	9				
2	91810130240	FASTENER	18				
3	91810130250	FASTENER	8				
5	31657280200	COVER	2				
6	90186208020	BOLT,FLANGE	8		M8X20		
7	90280200800	NUT,FLANGE	8		M8		
8	31653470100	SUPPORT	1				
9	31653470200	SUPPORT	1				
10	90186206010	BOLT,FLANGE	15		M6X10		
11	31611822200	HARNESS	1		L=13000		
12	82100001371	TERMINAL	1				
13	82100001227	INSULATOR	1				
14	31478092100	HARNESS	1				
17	82100000192	TERMINAL	1				
18	82100000182	INSULATOR	1				
28	31478092400	COVER ASSY	1				
29	31478092600	HARNESS	1				
36	31478092500	COVER	1				
37	31478092301	COVER ASSY	1				
41	31653322200	SWITCH ASSY (WITH HARNESS,2-SW)	2				
42	82199514013	CAP	4				
43	82199504017	NUT	4		AT-401N		
44	31657282100	SUPPORT	2				
45	31656331200	PLATE,NAME	2				

TM-ZX500 41050601236A FRAME

Pos No.	Parts No	Parts Name	Qty	Unit	Technical Data	Serial No (Start)	Serial No (End)	Remarks
1	31652991700	PLUG (4-POLES,FEMALE)	1					
3	91810130250	FASTENER	3					
4	91850700101	CLAMP	1		L=208			

TM-ZX500 41050601236A FRAME

Pos No.	Parts No	Parts Name	Qty	Unit	Technical Data	Serial No (Start)	Serial No (End)	Remarks
1	31506121100	HARNESS	1					
2	34354781710	RELAY (WITH BRACKET)	1					
3	90280200600	NUT,FLANGE	1		M6			
4	80197586012	SCREW,MACHINE	1		M6X12			
5	91810130250	FASTENER	6					

TM-ZX500 41050601236A FRAME

Pos No.	Parts No	Parts Name	Qty	Unit	Technical Data	Serial No (Start)	Serial No (End)	Remarks
1	31734142100	SWITCH ASSY	1					
2	31656340100	SUPPORT	1					
3	91810130240	FASTENER	N					
4	91850310405	CLAMP (BLACK)	8					
5	31734142200	HARNESS	1					
6	90186208020	BOLT,FLANGE	3		M8X20			
7	90280200800	NUT,FLANGE	3		M8			
8	91850100802	CLAMP	3					
9	90101206025	BOLT	3		M6X25			
10	37000576020	PLATE	1					
11	90186206014	BOLT,FLANGE	4		M6X14			
12	31653740500	SWITCH ASSY	1					
14	90186208016	BOLT,FLANGE	2		M8X16			
16	31656101200	PLUG (2-POLES,FEMALE)	1					
31	80161302014	SCREW,MACHINE	2		M2X14			
32	90303070201	WASHER,PLAIN	2		2			
33	90302040201	WASHER,SPRING (2)	2					
34	90201200200	NUT	2		M2			
35	31652231120	SWITCH	1					
36	31653740510	SUPPORT	1					
37	31653740520	SUPPORT	1					
51	80197586012	SCREW,MACHINE	2		M6X12			
52	90280200600	NUT,FLANGE	2		M6			
53	34354781710	RELAY (WITH BRACKET)	2					
55	31658673100	COVER	1					
56	37002227560	PLATE,NAME (BLACK)	2		D=16			

TM-ZX500 41050601236A FRAME

Pos No.	Parts No	Parts Name	Qty	Unit	Technical Data	Serial No (Start)	Serial No (End)	Remarks
1	36072815010	CASE,GEAR	1					
2	36072815020	COVER	1					
3	36072815030	RETAINER (BEARING)	1					
4	36072815040	FRAME	1					
5	36072815050	FRAME	1					
6	36072815060	FLANGE (MOTOR)	1					
7	36072815070	WORM	1					
8	36072815080	WHEEL,WORM	1					
9	36072815090	DRUM,SHAFT	1					
10	36072815100	DRUM	1					
11	36072815110	CLUTCH	1					
12	36072815120	CLUTCH	1					
13	36072815130	COLLAR	1					
14	36072815140	COLLAR	1					
15	36072815150	COLLAR	1					
16	36072815160	PLATE (SHIM)	1					
17	36072815170	ROLLER	1					
18	36072815180	SHAFT (ROLLER)	1					
19	36072815190	ARM (ROLLER)	2					
20	36072815200	SPRING	2					
21	36072815210	BOLT (TENSION)	2					
22	36072815220	GUIDE (WIRE)	1					
23	36072815230	STAND (ROLLAR)	1					
24	36072815240	FORK (CHENGE)	1					
25	36072815250	SHAFT	1					
26	36072815260	GUIDE,BLOCK	1					
27	36072815270	COVER	1					
28	36072815280	PLATE	1					
29	36072815290	CASE	1					
30	36072815300	PLATE	1					
31	36072815310	COVER	1					
32	36072815320	GEAR	1					
33	36072815330	KEY	2					
34	36072815340	KEY	1					
35	36072815350	FACING	1					
36	80500006212	BEARING,BALL	1					
37	80500006012	BEARING,BALL	1					
38	80516006208	BEARING,BALL	1					
39	80516006202	BEARING,BALL	2					
40	36070525350	BEARING,ROLLER	1					
41	36070525360	BEARING,ROLLER	1					
42	91206060003	SEAL,OIL	1					
43	36072815360	SEAL,OIL	1					
44	36072815370	PACKING (SEAT)	1					
45	36072815380	SEAL,DUST	1					
46	36072815390	RING	1					
47	91001207000	O-RING	1		1A G70			
48	91001205500	O-RING	1		1A G55			
49	80601110400	RING,RITAINING	1		S40			
50	90151200100	BOLT,EYE	1		M10			
51	82400000478	BREATHER	1					
52	36070525390	PLUG	1		PT1/2X1/8			
53	80205000300	PLUG	1		PT3/8			
54	90172110060	BOLT,HEXAGON SOCKET	8		M10X60			
55	90172110040	BOLT,HEXAGON SOCKET	6		M10X40			
56	90302041001	WASHER,SPRING	14		10			
57	90101508025	BOLT	12		M8X25			
58	90171112030	BOLT	4		M12X30			
59	90171116035	BOLT	4		M16X35			
60	90171110045	BOLT	2		M10X45			
61	90171106010	BOLT,HEXAGON SOCKET	4		M6X10			
62	36072815400	PIN (PARALLEL)	2					
63	80205000200	PLUG	1		PT1/4			

TM-ZX500 41050601236A FRAME

Pos No.	Parts No	Parts Name	Qty	Unit	Technical Data	Serial No (Start)	Serial No (End)	Remarks
1	31310647530	GEAR,SPUR	1					
2	31310647540	PIN	2					
3	31310687520	DRUM	1					
4	80516006306	BEARING,BALL	1					
5	80516006206	BEARING,BALL	1					
6	90172410025	BOLT,HEXAGON SOCKET	4		M10X25			
7	90302041001	WASHER,SPRING	4		10			
100	31310680300	DRUM,WINCH (Y.G.TEC)	1					

TM-ZX500 41050601236A FRAME

Pos No.	Parts No	Parts Name	Qty	Unit	Technical Data	Serial No (Start)	Serial No (End)	Remarks	Pages
1	53037260000	HOOK	1						000051
2	83151211401	CLIP	1						
3	83151111401	CLIP	1						
4	37001806200	ROPE,WIRE	1		14X30M				
5	37002600230	WEDGE	1		14				

TM-ZX500 41050601236A FRAME

Pos No.	Parts No	Parts Name	Qty	Unit	Technical Data	Serial No (Start)	Serial No (End)	Remarks
1	90191510020	BOLT,HEXAGON SOCKET	8		M10X20			
2	90302041001	WASHER,SPRING	8		10			
3	90303071001	WASHER,PLAIN	4		10			
4	36093860021	BODY	1					
5	36093860042	SUPPORT	1					
6	37001008670	SHEAVE ASSY	2					
7	80720105056	PIN,SPRING	1		5X56			
9	36093860031	BODY	1					
10	36093860080	COVER	2					
12	80500051207	BEARING,BALL	1					
13	36093860071	TRUNNION	1					
21	36095155020	HOOK ASSY	1					
32	36093861100	BEARING,BALL	2					
40	36095150050	TRIGGER SET	1					
100	36095150000	HOOK (LOCKING)	1					

TM-ZX500 41050601236A FRAME

Pos No.	Parts No	Parts Name	Qty	Unit	Technical Data	Serial No (Start)	Serial No (End)	Remarks
1	36662650000	MOTOR,HYDRAULIC	1					
2	90302041201	WASHER,SPRING	6		12			
3	90172112035	BOLT,HEXAGON SOCKET	2		M12X35			
4	36072800000	WINCH (SELF)	1					
5	31311131000	GUARD	1					
6	90171116045	BOLT	8		M16X45			
7	90302041601	WASHER,SPRING	8		16			
8	91000515200	O-RING	1		AS568-152			
10	14124015000	BOLT	3					
11	90201201200	NUT	6		M12			
12	90101212020	BOLT	4		M12X20			
13	37000136790	PIN ASSY	1					
14	90303071201	WASHER,PLAIN	2		12			
15	80136340020	PIN,SPLIT	1		4X20			
16	31322224200	PLATE	2		L=1			
17	37001300250	SPRING	3					
31	31311139520	SUPPORT ASSY	1					
32	31311139510	ROLLER ASSY	1					
33	31311130530	PIN	1					
34	80516006203	BEARING,BALL	2					
41	80136340020	PIN,SPLIT	1		4X20			
42	37000136800	PIN	1					

TM-ZX500 41050601236A FRAME
PH1060491-01 DETECTOR,OVERWIND

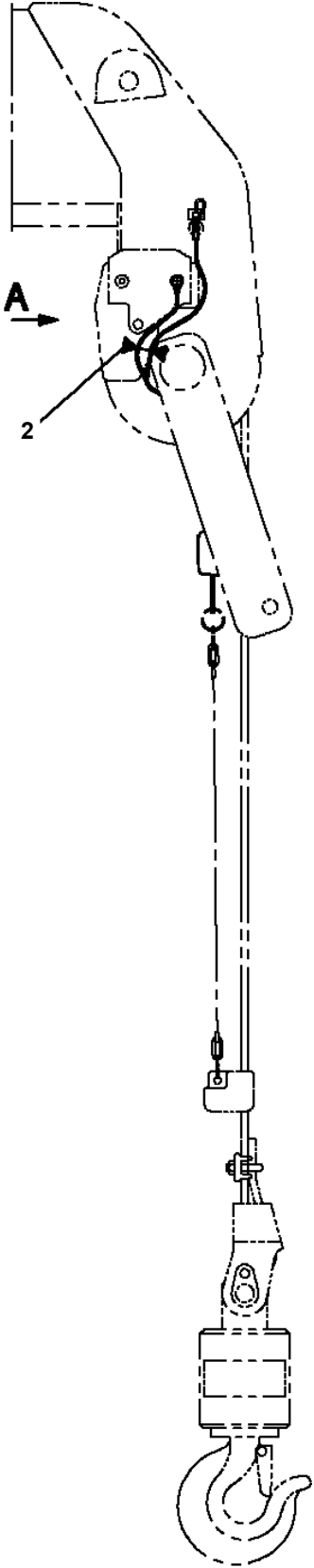
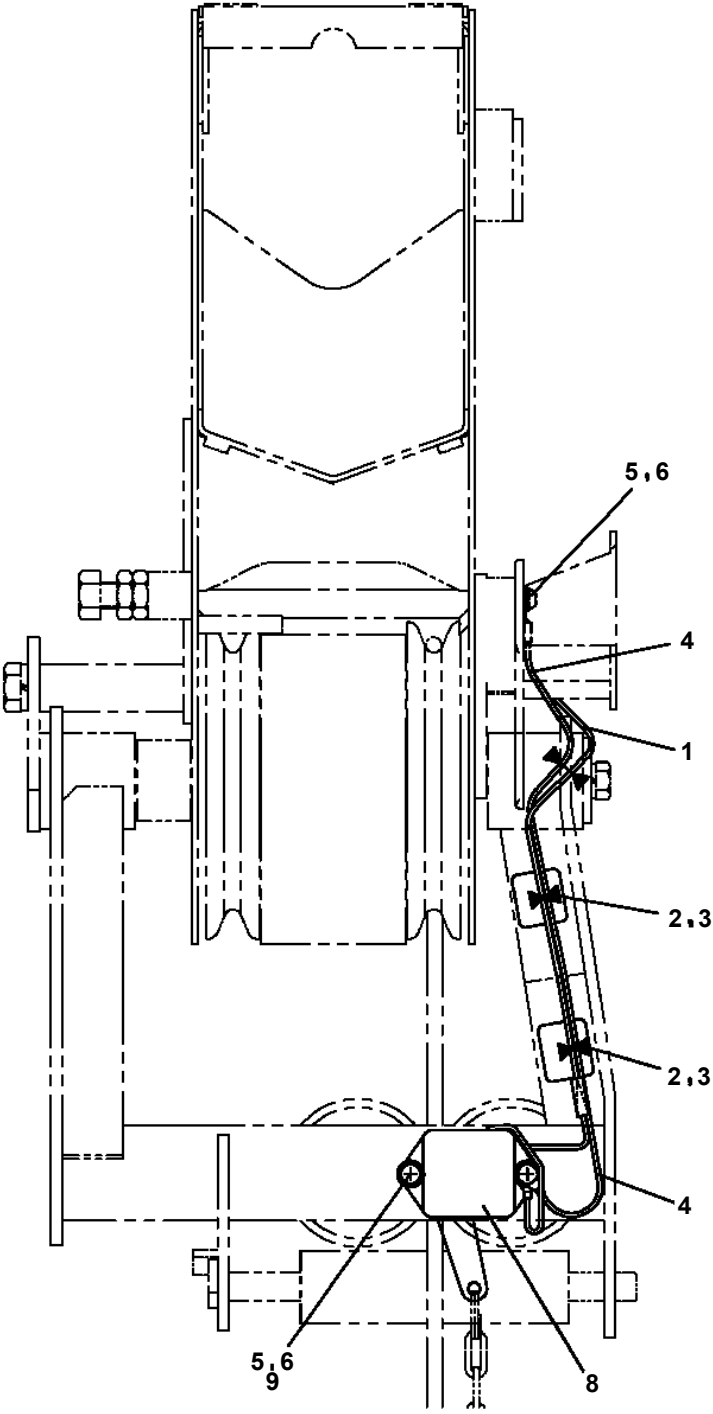

A

TM-ZX500 41050601236A FRAME
PH5033592-00 HARNESS

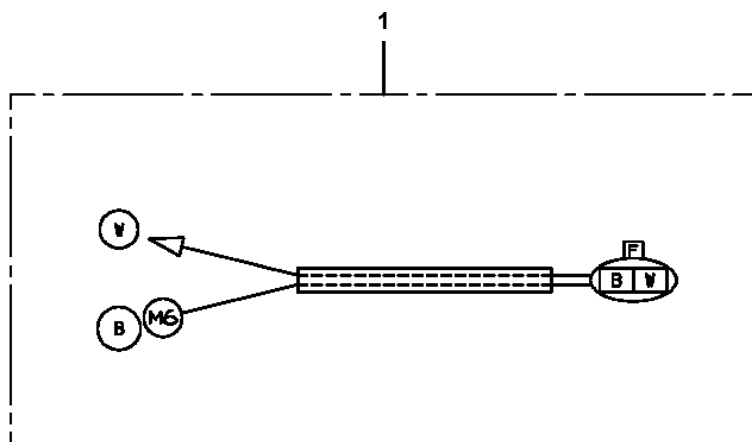

**TM-ZX500 41050601236A FRAME
PH5034112-00 HARNESS**

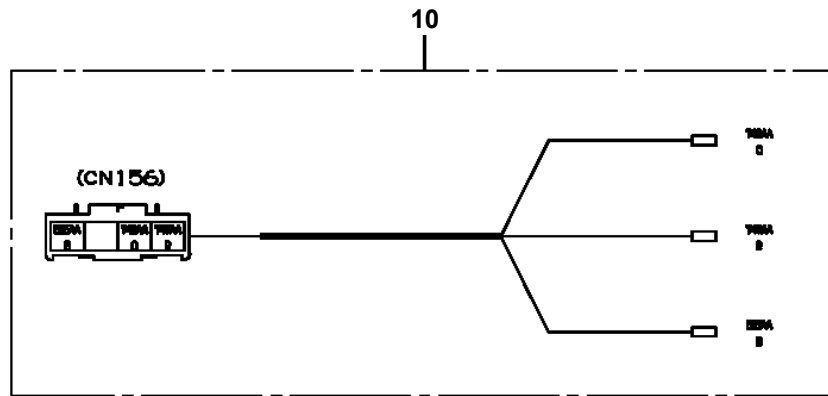

TM-ZX500 41050601236A FRAME
PH5034489-00 HARNESS

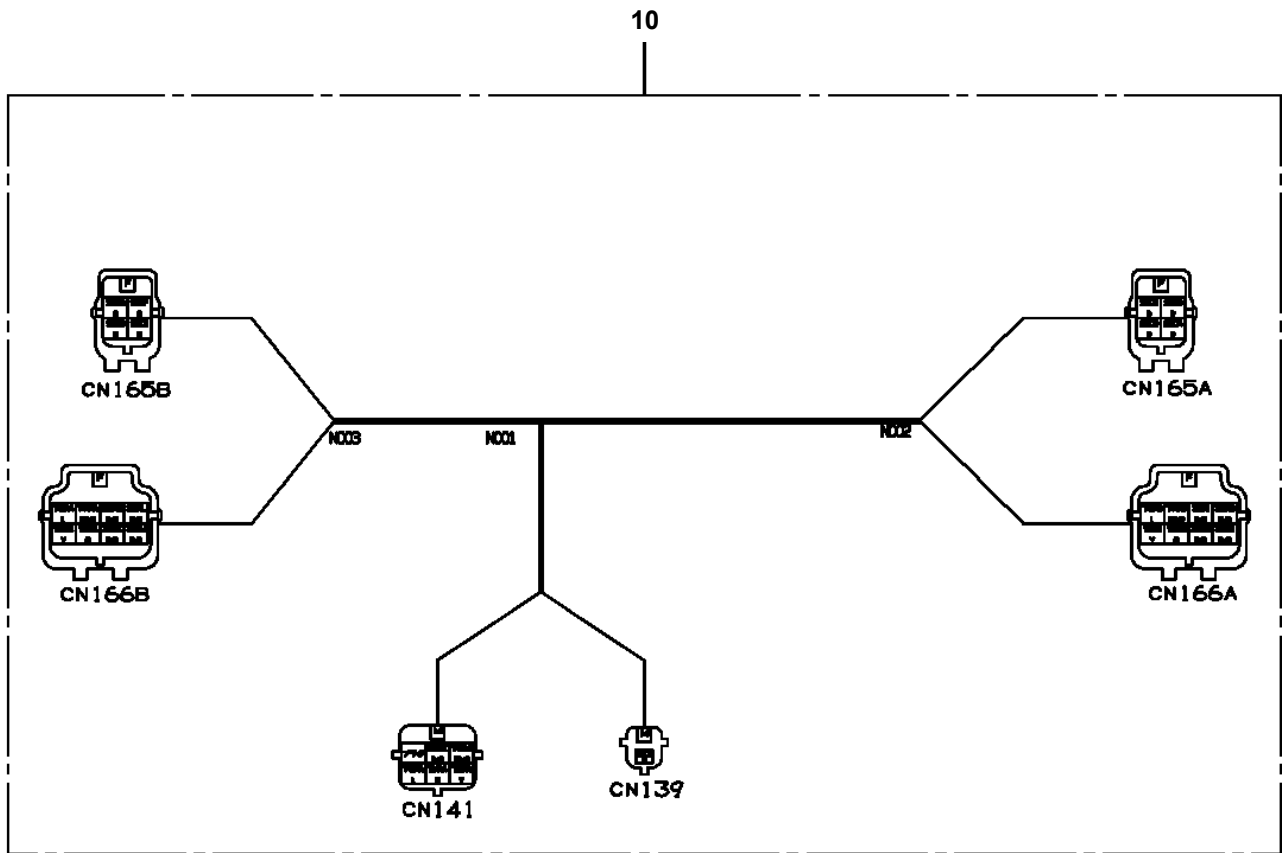

TM-ZX500 41050601236A FRAME
PI1010223-01 MOTOR, HYDRAULIC

200

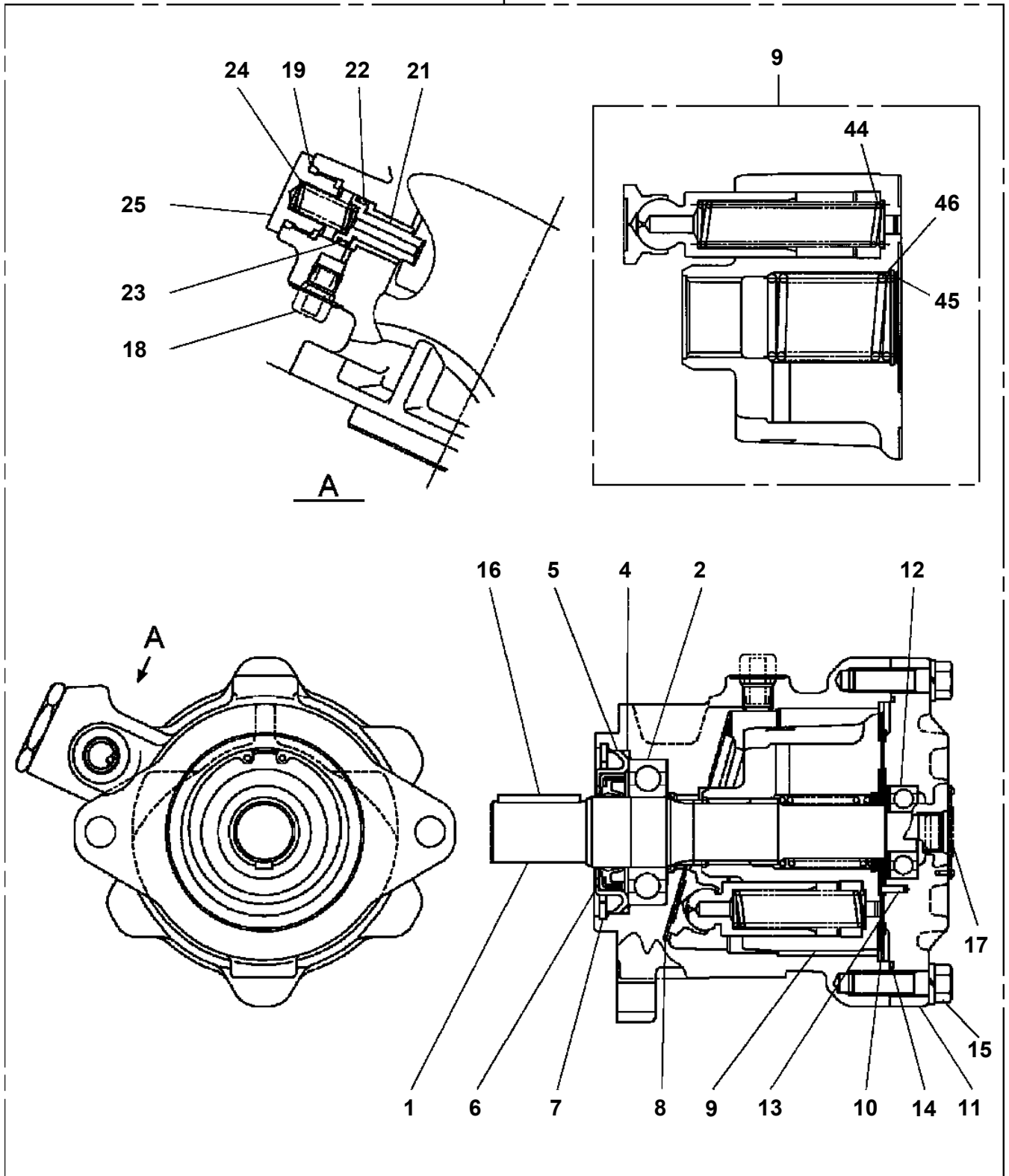

**TM-ZX500 41050601236A FRAME
PI1300026-01 FILTER,OIL (WAKO)**

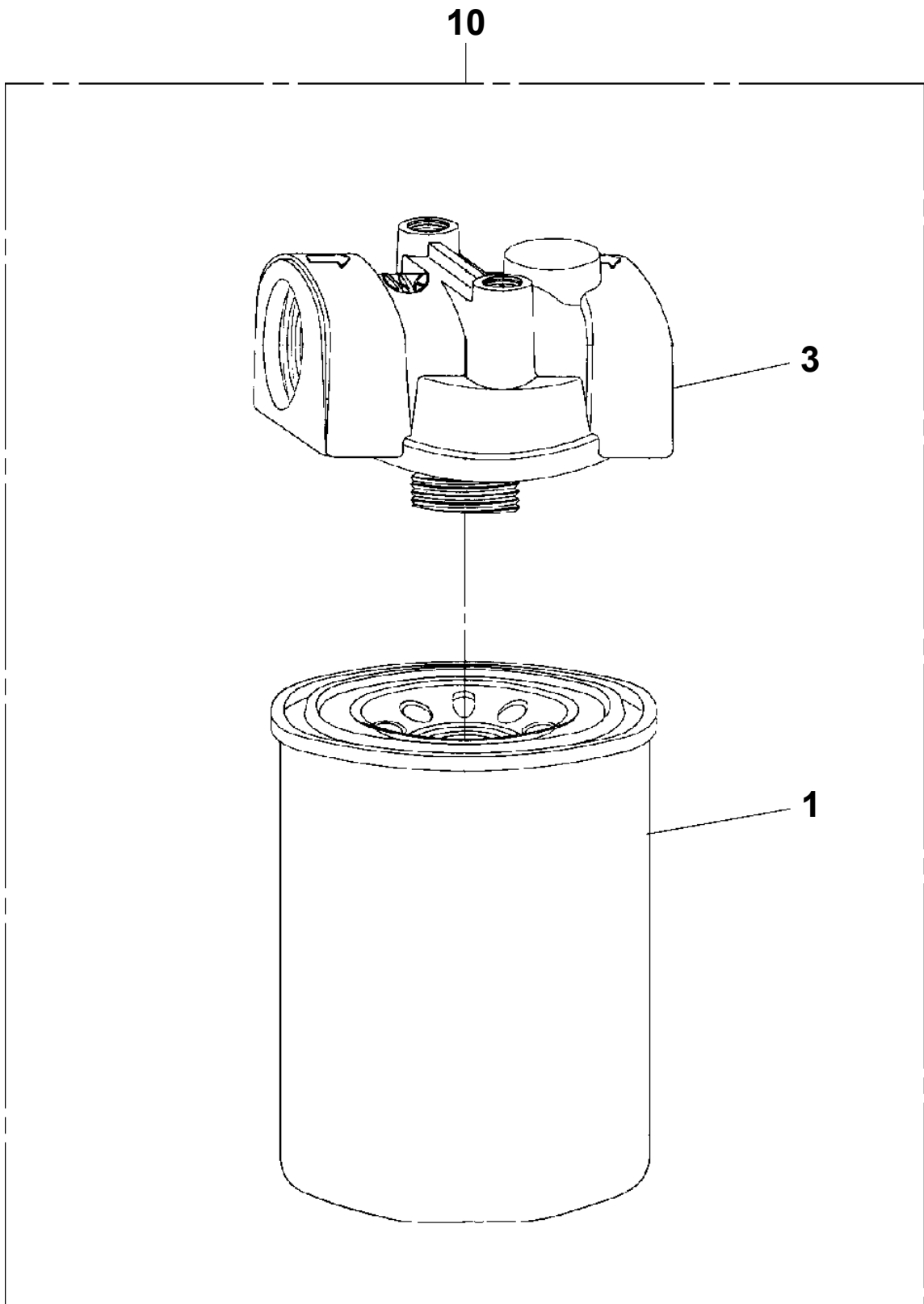

TM-ZX500 41050601236A FRAME
PJ5090137-00 JOINT ASSY, SWIVEL

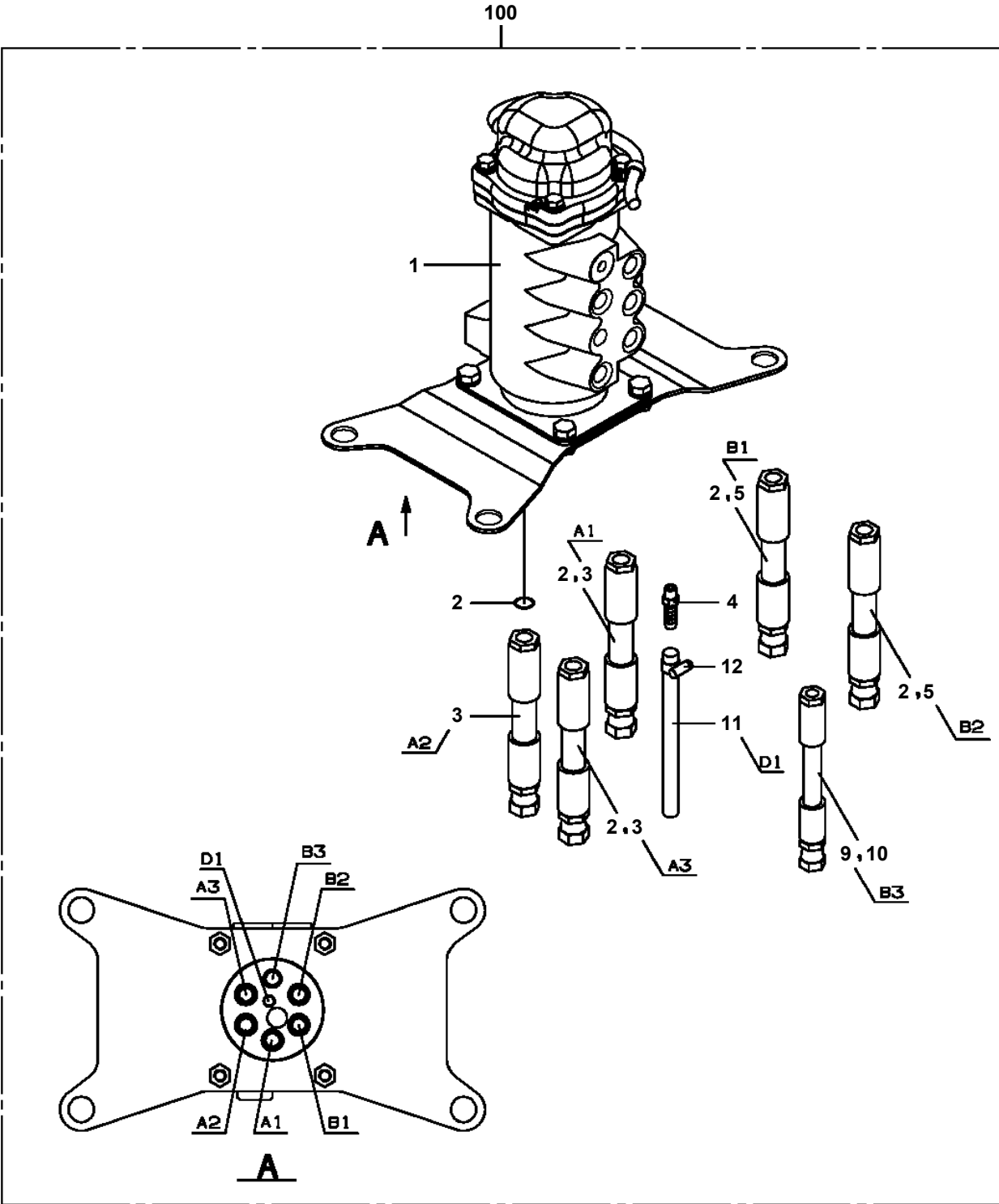

**TM-ZX500 41050601236A FRAME
PK2002546-00 FRAME UNIT (SPEC. DISTINCTION)**

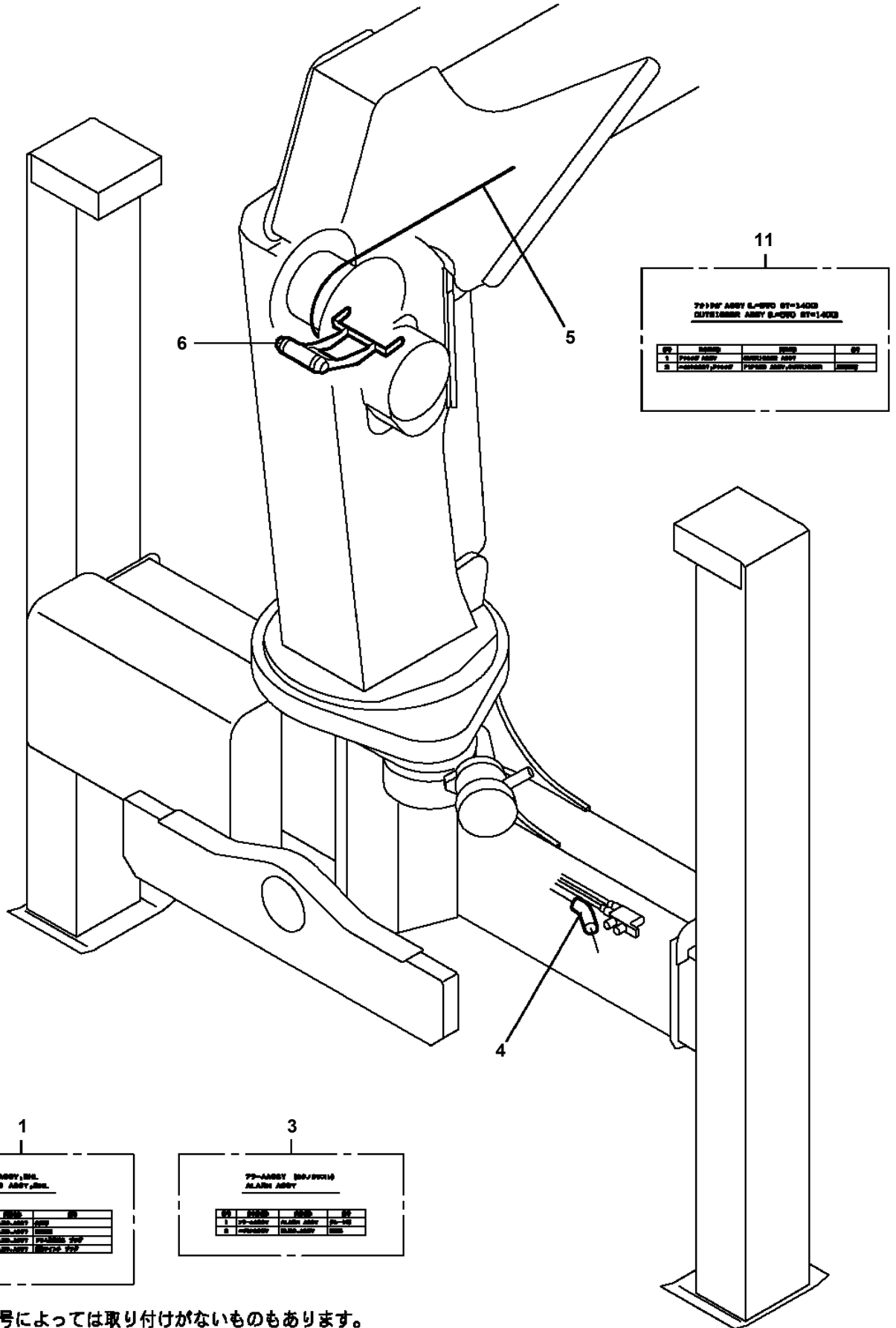

11

**791007 ASBY S-4000 BT=3400
CUTSLASER ASBY S-4000 BT=1400**

QT	NAME	UNIT	QTY
1	PINNED ASBY	DISASSEMBLY ASBY	
2	ASSEMBLY PINNED	PINNED ASBY,DISASSEMB	DISASBY

1

**79-300007,ENL.
PARTS ASBY,ENL.**

QT	NAME	UNIT	QTY
11	ASSEMBLY	DISASSEMBLY ASBY	
12	ASSEMBLY	DISASSEMBLY ASBY	
13	ASSEMBLY	DISASSEMBLY ASBY	
14	ASSEMBLY	DISASSEMBLY ASBY	

3

**79-300007,ENL.
PARTS ASBY,ENL.**

QT	NAME	UNIT	QTY
1	ASSEMBLY	DISASSEMBLY ASBY	
2	ASSEMBLY	DISASSEMBLY ASBY	

適用製造番号によっては取り付けがないものもあります。

MACHINES OF SOME SERIAL NO. ARE NOT EQUIPPED WITH THESE PARTS.

TM-ZX500 41050601236A FRAME
PL5020226-00 LAMP ASSY (BOOM/24V-20W)

ランプ ASSY (フーム/24V-20W)
LAMP ASSY (BOOM/24V-20W)

フーム取付けタイプ
ランプ仕様：24V-20W

符号	日本語名称	英語名称	備考
2	ハイセンASSY	ELEC.ASSY	ホースト部
3	ハイセンASSY	ELEC.ASSY	フーム部 (LED20W)

適用製造番号によっては取り付けがないものもあります。

MACHINES OF SOME SERIAL NO. ARE NOT EQUIPPED WITH THESE PARTS.

TM-ZX500 41050601236A FRAME
PL5330004-00 LAMP

100

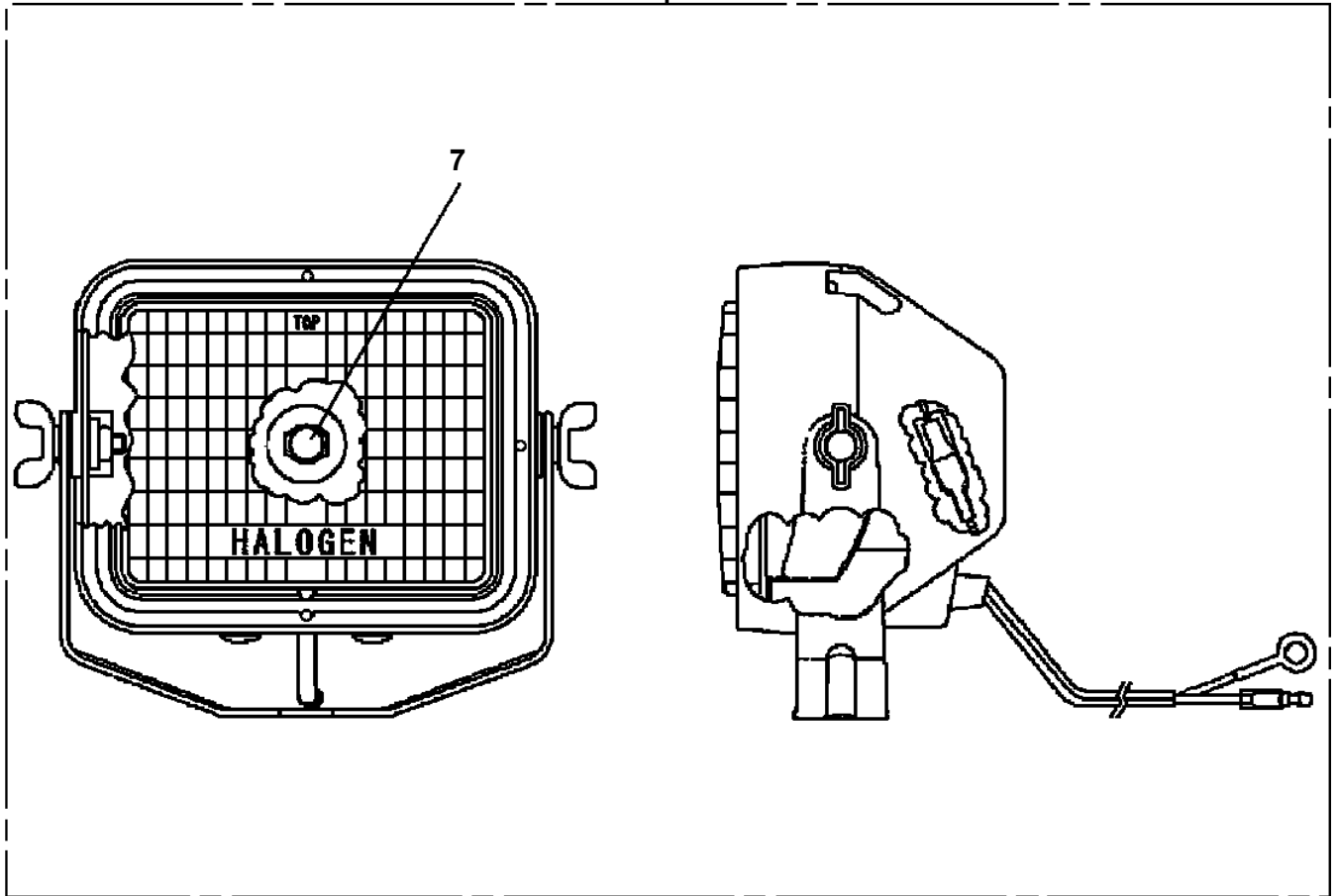

CLICK HERE TO **DOWNLOAD** THE COMPLETE MANUAL

- Thank you very much for reading the preview of the manual.
- You can download the complete manual from: www.heydownloads.com by clicking the link below



- Please note: If there is no response to CLICKING the link, please download this PDF first and then click on it.

CLICK HERE TO **DOWNLOAD** THE COMPLETE MANUAL

**TM-ZX500 41050601236A FRAME
PN5012014-02 NAME PLATE ASSY (FRAME:TDN-LAYOUT)**

ネームプレートASSY (フレーム:タタノハイレッツ)
NAME PLATE ASSY (FRAME:TDN-LAYOUT)

符号	日本語名称	英語名称	備考
1	ネームプレートASSY	NAME PLATE ASSY	ノブ銘板:タタノ配列 (SL)
4	ネームプレートASSY	NAME PLATE ASSY	タンク油量銘板:共通
5	ネームプレートASSY	NAME PLATE ASSY	フック銘板:共通
6	ネームプレートASSY	NAME PLATE ASSY	O/R注意銘板等
7	ネームプレートASSY	NAME PLATE ASSY	定期自主検査銘板
8	ネームプレートASSY	NAME PLATE ASSY	ノブ銘板 SLジャッキ

適用製造番号によっては取り付けがないものもあります。

MACHINES OF SOME SERIAL NO. ARE NOT EQUIPPED WITH THESE PARTS.

**TM-ZX500 41050601236A FRAME
PN5012020-01 NAME PLATE ASSY (TANK)**

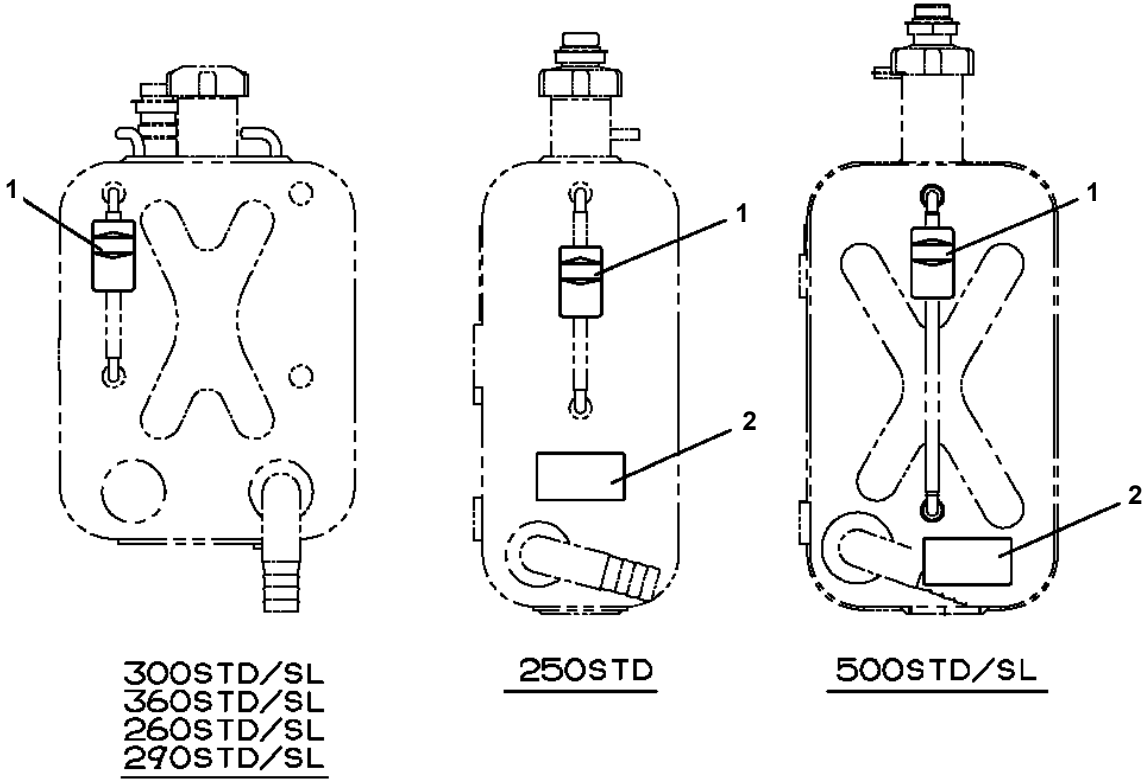
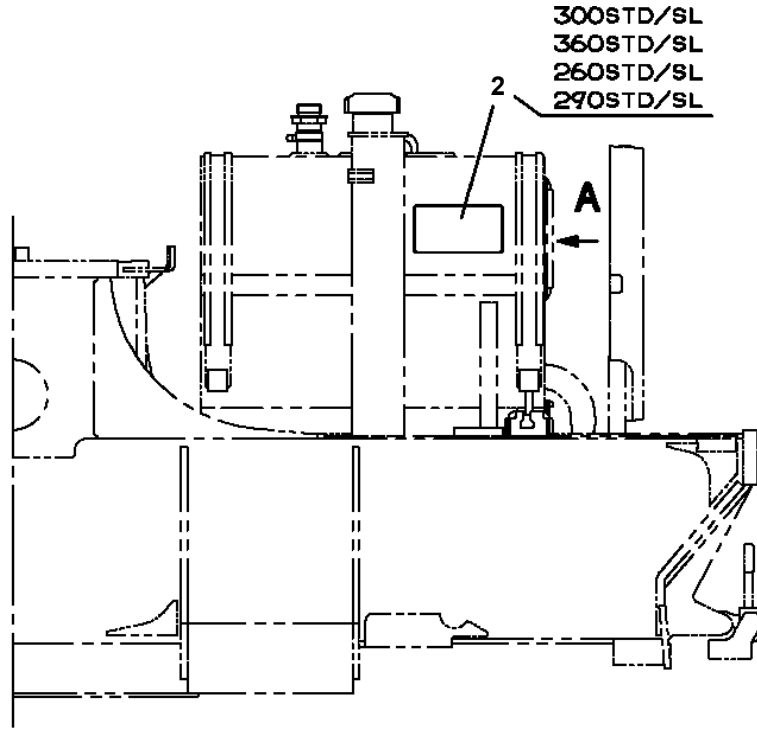

A

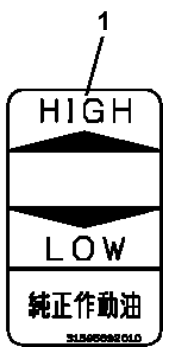

TM-ZX500 41050601236A FRAME
PN5012122-00 NAME PLATE ASSY

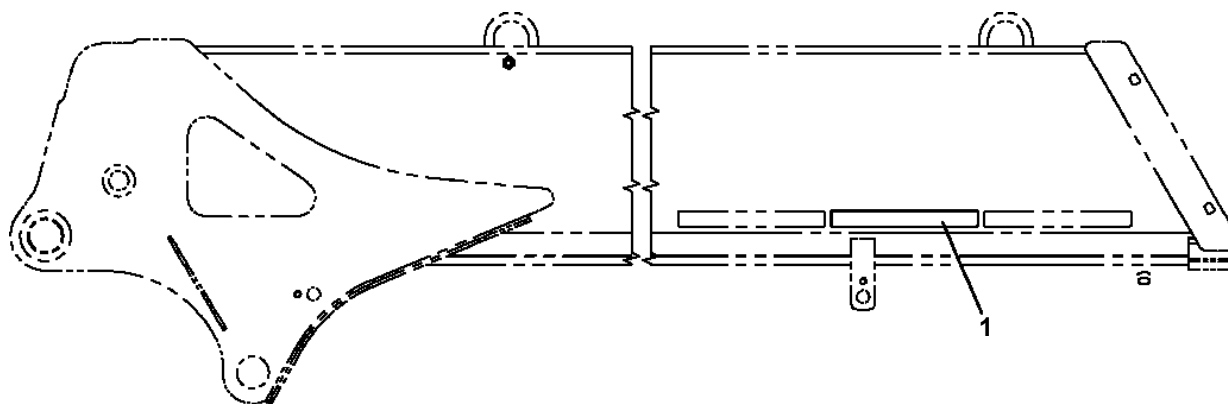

1
フォークジャッキ インターロック装置付

TM-ZX500 41050601236A FRAME
 PN5012165-01 NAME PLATE ASSY (JSAS)

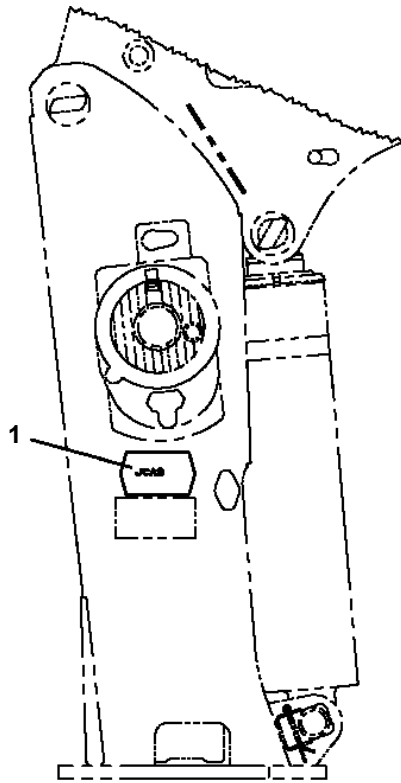

ZX250, ZX260, ZX290
 ZX300, ZX360
 ZS500, ZS580
 ZX500

ポスト側面

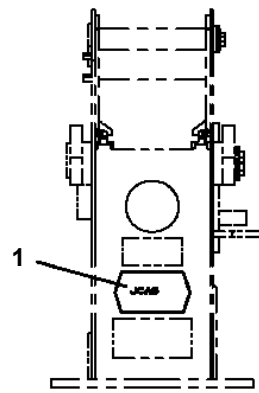

ZS220
 ポスト前面

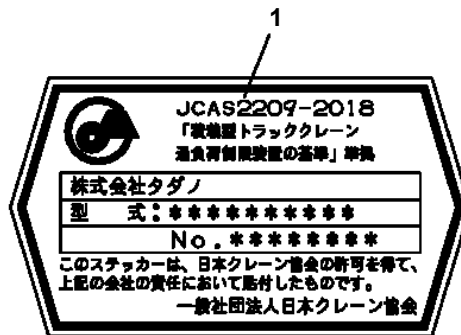

TM-ZX500 41050601236A FRAME

Pos No.	Parts No	Parts Name	Qty	Unit	Technical Data	Serial No (Start)	Serial No (E
1	(***** *****)	NAME PLATE ASSY (FRAME:U-LAYOUT)	1				
	(***** *****)	NAME PLATE ASSY (FRAME:TDN-LAYOUT)	1				
2	(***** *****)	PLATE ASSY,NAME (POST)	1				
5	(***** *****)	PERFORMANCE DATA (A)	1				
6	(***** *****)	PERFORMANCE DATA (B)	1				
7	(***** *****)	PERFORMANCE DATA (C)	1				
8	(***** *****)	NAME PLATE ASSY	1				
9	(***** *****)	NAME PLATE ASSY (JSAS)	1				
11	(***** *****)	PLATE ASSY,NAME (FRAME SERIAL NO.)	1				

TM-ZX500 41050601236A FRAME

Pos No.	Parts No	Parts Name	Qty	Unit	Technical Data	Serial No (Start)	Serial No (End)	Remarks	Pages
1	(*****)	PLATE,NAME (NETIS)	1						

TM-ZX500 41050601236A FRAME

Pos No.	Parts No	Parts Name	Qty	Unit	Technical Data	Serial
1	(*****)	OPE.ASSY,CONT.VALVE (ELEVATING,WINCH,TELESCOPING/U)	1			
2	31595701000	NAME PLATE ASSY (KNOB:U-LAYOUT)	1			
4	31323330100	KNOB (BLACK)	6			

TM-ZX500 41050601236A FRAME

Pos No.	Parts No	Parts Name	Qty	Unit	Technical Data	Serial No (Start)	Serial No (End)
1	(*****)	CYLINDER,JACK (REAR/STROKE 330MM)	2				
2	(*****)	FRAME ASSY (REAR)	1				
11	31621340300	SUPPORT	2				
12	90171116050	BOLT	8		M16X50		
13	90202781600	NUT	16		M16		
15	37000539370	PLATE	2				

TM-ZX500 41050601236A FRAME

Pos No.	Parts No	Parts Name	Qty	Unit	Technical Data	Serial No (Start)	Serial No (End)	Remarks	Pages
1	31598031500	PLATE,CAUTION	2						
2	31598031600	PLATE,NAME	1						

TM-ZX500 41050601236A FRAME

Pos No.	Parts No	Parts Name	Qty	Unit	Technical Data	Serial No (Start)	Serial No (End)	Remarks	Pages
1	31232121100	POST	1						
2	37000177540	PIN	1						
3	80136363080	PIN,SPLIT	1		6.3X80				
4	37000209240	PIN	1						
5	31230622500	COVER	1						
6	31630302000	PLATE	1		T=1.5				
7	90101210016	BOLT	2		M10X16				
8	31630482000	PLATE	1						
9	90186208010	BOLT,FLANGE	2		M8X10				
51	31230580220	SUPPORT	2						

TM-ZX500 41050601236A FRAME

Pos No.	Parts No	Parts Name	Qty	Unit	Technical Data	Serial No (Start)	Serial No (End)	Remarks	P
1	37001809030	ROPE,WIRE (KISWIRE)	1						

TM-ZX500 41050601236A FRAME

Pos No.	Parts No	Parts Name	Qty	Unit	Technical Data	Serial No (Start)	Serial No (End)	Remarks
1	82105501003	SWITCH,TOGGLE	1					
2	82101940120	SWITCH,PUSH (PLATING)	1		3PJW106F-021-AB			
10	31734142110	SWITCH ASSY	1					

TM-ZX500 41050601236A FRAME

Pos No.	Parts No	Parts Name	Qty	Unit	Technical Data	Serial No (Start)	Serial No (End)	Remarks	Pages
10	36804914000	BOX,STOWING	1						

TM-ZX500 41050601236A FRAME

Pos No.	Parts No	Parts Name	Qty	Unit	Technical Data	Serial No (Start)	Serial No (End)	R
100	36743460000	VALVE ASSY,REMOTE CONTROL	1					

TM-ZX500 41050601236A FRAME

Pos No.	Parts No	Parts Name	Qty	Unit	Technical Data	Serial No (Start)	Serial No (End)	Rema
1	37001500000	BOLT	1					
2	90302041201	WASHER,SPRING	1		12			
3	90303101201	WASHER,PLAIN	1		12			
4	90172110028	BOLT,HEXAGON SOCKET	3		M10X28			
5	90302041001	WASHER,SPRING	3		10			
6	90303071001	WASHER,PLAIN	3		10			
7	36073810000	WINCH ASSY (Y.G.TEC)	1					
8	82401800080	PLUG (FOR M8)	2					
9	31310610500	BREATHER,AIR	1					
10	90172108025	BOLT,HEXAGON SOCKET	2		M8X25			
11	90302040801	WASHER,SPRING	2		8			
12	36663100000	MOTOR,HYDRAULIC (WINCH)	1					
13	91001206000	O-RING	1		1A G60			
14	37000177560	PIN	1					
15	90186210014	BOLT,FLANGE	2		M10X14			
16	37000300350	SPACER	1		L=18.5			
17	31310391000	COVER	1					
18	31310680300	DRUM,WINCH (Y.G.TEC)	1					
	31310680100	DRUM,WINCH (HARTYS)	1					
19	37002600190	WEDGE	1		8			
20	37000312690	SPACER	1		L=26.5			

**TM-ZX500 41050601236A FRAME
PZ0000000-00 DERRICK ASSY (WITH CV)**

販売部品 検討中につき、イラストはありません。

**Parts for sale : Under consideration now.
Therefore not illustrated.**

販売部品 検討中につき、イラストはありません。

Parts for sale : Under consideration now.
Therefore not illustrated.

**TM-ZX500 41050601236A FRAME
PZ0000000-00 OUTRIGGER ASSY (LEFT)**

販売部品 検討中につき、イラストはありません。

**Parts for sale : Under consideration now.
Therefore not illustrated.**

**TM-ZX500 41050601236A FRAME
PZ0000000-00 OUTRIGGER ASSY (LEFT)**

販売部品 検討中につき、イラストはありません。

**Parts for sale : Under consideration now.
Therefore not illustrated.**

**TM-ZX500 41050601236A FRAME
PZ0000000-00 PIPING ASSY,OUTRIGGER**

販売部品 検討中につき、イラストはありません。

**Parts for sale : Under consideration now.
Therefore not illustrated.**

**TM-ZX500 41050601236A FRAME
PZ0000000-00 PIPING ASSY**

販売部品 検討中につき、イラストはありません。

**Parts for sale : Under consideration now.
Therefore not illustrated.**

**TM-ZX500 41050601236A FRAME
PZ0000000-00 MOUNT ASSY (ACCELERATOR)**

販売部品 検討中につき、イラストはありません。

**Parts for sale : Under consideration now.
Therefore not illustrated.**

**TM-ZX500 41050601236A FRAME
PZ0000000-00 PIPING ASSY (CRANE)**

販売部品 検討中につき、イラストはありません。

**Parts for sale : Under consideration now.
Therefore not illustrated.**

**TM-ZX500 41050601236A FRAME
PZ0000000-00 HARNESS**

販売部品 検討中につき、イラストはありません。

**Parts for sale : Under consideration now.
Therefore not illustrated.**

CLICK HERE TO **DOWNLOAD** THE COMPLETE MANUAL

- Thank you very much for reading the preview of the manual.
- You can download the complete manual from: www.heydownloads.com by clicking the link below



- Please note: If there is no response to CLICKING the link, please download this PDF first and then click on it.

CLICK HERE TO **DOWNLOAD** THE COMPLETE MANUAL