

TM-ZX290 41047701345A FRAME

PB0000365-00 SYSTEM (ZX290SL,DOMESTIC)

ASSEMBLY

CLICK HERE TO **DOWNLOAD** THE COMPLETE MANUAL

- Thank you very much for reading the preview of the manual.
- You can download the complete manual from: www.heydownloads.com by clicking the link below



- Please note: If there is no response to CLICKING the link, please download this PDF first and then click on it.

CLICK HERE TO **DOWNLOAD** THE COMPLETE MANUAL

TM-ZX290 41047701345A FRAME

Pos No.	Parts No	Parts Name	Qty	Unit	Technical Data	Serial No (Start)	Serial No (End)	R
5	36401650000	POWER TAKE OFF	1					
	36401600000	POWER TAKE OFF	1					
	31790860000	POWER TAKE OFF	1					
	31790870000	POWER TAKE OFF	1					
	36401600001	POWER TAKE OFF	1					
6	52230312000	POWER TAKE OFF (WITH TURBO)	1					
	36401650000	POWER TAKE OFF	1					
	36401600000	POWER TAKE OFF	1					
	31790860000	POWER TAKE OFF	1					
	52230314000	POWER TAKE OFF	1					
7	31790760000	POWER TAKE OFF	1					
	31790720000	POWER TAKE OFF	1					

TM-ZX290 41047701345A FRAME

Pos No.	Parts No	Parts Name	Qty	Unit	Technical Data	Serial No (Start)	Serial No (End)	Remarks	Pages
1	36400565010	CASE	1						
2	36400565020	GEAR	1						
3	36400235040	SHAFT	1						
4	36400565030	GEAR	1						
5	36400095040	SHAFT	1						
6	36400095050	COLLAR	1						
7	36400095100	SHIFTER ASSY	1						
8	36400095110	PACKING	2						
9	36400235050	COVER (FRONT)	1						
10	36400235060	COVER (REAR)	1						
11	36400235070	PACKING	2						
12	36400095090	SHIM	N						
13	80500006305	BEARING,BALL	2						
14	36400095120	BEARING	2						
15	91206025005	SEAL,OIL	1						
16	36400095130	WASHER	1						
17	90101206012	BOLT	1		M6X12				
18	80602110520	RING,RITAINING	2		R52				
19	90191210016	BOLT	8		M10X16				
20	90302041001	WASHER,SPRING	14		10				
21	90191208030	BOLT	4		M8X30				
22	90302040801	WASHER,SPRING	4		8				
23	36400135120	COUPLING	1						
24	36400135100	KEY	1						
25	36400135150	NUT	1		M4X1.5				
26	36400135160	WASHER,PLAIN	1						
27	36400135090	WASHER	1						
30	36400075140	COVER (1)	1						
31	90193210025	BOLT	3		M10X25				
32	36400195030	BOLT,STUD	3						
33	90267201000	NUT	3		M10				
35	31790670100	SUPPORT	1						
36	90191208025	BOLT	2		M8X25				
50	36400560000	POWER TAKE OFF	1						
100	31790730000	POWER TAKE OFF	1						

TM-ZX290 41047701345A FRAME

Pos No.	Parts No	Parts Name	Qty	Unit	Technical Data	Serial No (Start)	Serial No (End)	Remarks	Page
1	36401165010	CASE	1						
2	36401135060	GEAR (TO)	1						
3	36401165020	SHAFT	1						
4	36401125040	SLEEVE	1						
5	36401125050	SHIFTER SET	1						
6	36400095110	PACKING	1						
7	36400095070	COVER (BEARING)	1						
8	36400095080	PACKING (COVER)	1						
9	36400095090	SHIM	1						
10	36401135070	COLLAR	1						
11	80500006903	BEARING,BALL	1						
12	36401125080	BEARING,ROLLER	2						
13	36401125090	BEARING,NEEDLE	1						
14	91206030005	SEAL,OIL	1						
15	36401165030	NUT	1						
16	36401165040	WASHER	1						
17	90191208020	BOLT	4		M8X20				
18	90191208014	BOLT	3		M8X14				
19	90302040801	WASHER,SPRING	7		8				
20	36400135120	COUPLING	1						
21	36400135100	KEY	1						
22	36401165050	NUT	1		M14X1.5				
23	36400135080	WASHER,PLAIN	1						
24	36400135090	WASHER	1						
26	36401125120	PACKING (CASE)	1						
27	90191210100	BOLT	1		M10X100				
28	90191210090	BOLT	1		M10X90				
29	90191210030	BOLT	2		M10X30				
30	36400095150	BOLT,STUD	1		M10X1.25/1.5X43				
31	36401125140	BOLT	1						
32	90267201000	NUT	2		M10				
33	90302041001	WASHER,SPRING	6		10				
34	31790880100	SUPPORT	1						
35	90191208025	BOLT	2		M8X25				
50	36401160000	POWER TAKE OFF	1						
100	31790900000	POWER TAKE OFF	1						

TM-ZX290 41047701345A FRAME

Pos No.	Parts No	Parts Name	Qty	Unit	Technical Data	Serial No (Start)	Serial No (
1	36401655010	CASE,GEAR	1				
3	52230312180	BOLT (WITH WASHER)	8		M8X1.25		
4	52230312160	WASHER,SPRING	1				
5	52230308050	COVER (CASE)	1				
6	80500006305	BEARING,BALL	2				
7	52230312021	SHAFT (OUTPUT)	1				
8	36401595020	COLLAR (THRUST)	1				
9	52230312140	ROD (SHAFT)	1				
10	52230312030	SEAL,OIL	1				
11	52230308100	SHAFT (IDLE)	1				
13	52230312190	COVER (UPPER)	1				
14	52230312200	PACKING (COVER)	1				
15	52230308130	PIN,SPRING	1		4X24		
16	36401595030	ARM (SHAFT)	1				
17	52230312220	SLEEVE	1				
18	52230308170	PLUG (SHAFT)	1				
19	52230312051	SEAL,OIL	1				
20	52230312120	BOLT,STUD	2				
21	90302041001	WASHER,SPRING	2		10		
22	90267201000	NUT	2		M10		
23	52230312290	GEAR ASSY	1				
27	52230312250	GEAR	1				
28	52230312230	BOLT (WITH WASHER)	4		M8X1.25		
29	52230312090	BEARING,NEEDLE	2				
30	52230312280	BOLT	4		M8X1.25		
31	52230312270	BOLT,HEXAGON SOCKET	1		M8X1.25		
32	52230308160	SPRING (LOCK)	1				
33	52230312150	PIN (LOCK)	1				
34	52230307020	COUPLING	1				
35	52230312260	PIN,SPRING	1				
36	52230312060	ADAPTER	1				
50	36401659510	POWER TAKE OFF (WITHOUT COUPLING)	1				
100	36401650000	POWER TAKE OFF	1				

TM-ZX290 41047701345A FRAME

Pos No.	Parts No	Parts Name	Qty	Unit	Technical Data	Serial No (Start)	Serial No (End)	Remarks	Pages
1	36401725010	CASE	1						
2	36401725020	GEAR	1						
3	36401725030	SHAFT	1						
4	36400095040	SHAFT	1						
5	36400095050	COLLAR	1						
6	36401725040	GEAR	1						
7	36400095100	SHIFTER ASSY	1						
8	36400095120	BEARING	2						
9	80500006206	BEARING,BALL	2						
10	91206030005	SEAL,OIL	1						
11	36400095070	COVER (BEARING)	1						
12	36400095080	PACKING (COVER)	1						
13	36400095090	SHIM	N						
14	90101206012	BOLT	1		M6X12				
15	36400095130	WASHER	1						
16	90191208014	BOLT	3		M8X14				
17	90302040801	WASHER,SPRING	7		8				
18	36400095110	PACKING	1						
19	90191208020	BOLT	4		M8X20				
20	80602110520	RING,RITAINING	2		R52				
22	36400055070	PACKING	1						
23	36400195030	BOLT,STUD	4						
24	90267201000	NUT	4		M10				
25	90193210025	BOLT	2		M10X25				
26	90302041001	WASHER,SPRING	8		10				
27	36401725070	SUPPORT (PUMP)	1						
28	36401725080	BOLT	2		M10X35				
30	31791100100	SUPPORT	1						
31	90191208025	BOLT	2		M8X25				
50	36401730000	POWER TAKE OFF	1						
100	31791110000	POWER TAKE OFF	1						

TM-ZX290 41047701345A FRAME

Pos No.	Parts No	Parts Name	Qty	Unit	Technical Data	Serial No (Start)	Serial No (End)	Remarks
1	36401885010	CASE	1					
2	36401885020	GEAR	1					
3	36402515010	SHAFT	1					
4	36401885030	GEAR	1					
5	36400415050	SHAFT	1					
6	36400675030	COLLAR	1					
7	36401725050	SHIFTER ASSY	1					
8	36400095110	PACKING	1					
9	36400095070	COVER (BEARING)	1					
10	36400095080	PACKING (COVER)	1					
11	36400095090	SHIM	N					
12	80500006206	BEARING,BALL	2					
13	91206030005	SEAL,OIL	1					
14	91001102100	O-RING	1		1A P21			
15	90710006200	SCREW,SET	1		M6X20			
16	90191208020	BOLT	4		M8X20			
17	90191208014	BOLT	3		M8X14			
18	90302040801	WASHER,SPRING	7		8			
19	36400135070	BEARING	2					
20	80602110620	RING,RITAINING	2		R62			
22	36401885040	PACKING	1					
23	36400095150	BOLT,STUD	2		M10X1.25/1.5X43			
24	90191210030	BOLT	6		M10X30			
25	90267201000	NUT	2		M10			
26	90302041001	WASHER,SPRING	8		10			
27	90191208025	BOLT	2		M8X25			
28	31790670100	SUPPORT	1					
50	36402510000	POWER TAKE OFF ASSY	1					
100	31792480000	POWER TAKE OFF	1					

TM-ZX290 41047701345A FRAME

Pos No.	Parts No	Parts Name	Qty	Unit	Technical Data	Serial No (Start)	Serial No (End)	Remarks	Pages
1	36401420000	POWER TAKE OFF	1						00001
2	31790990100	SUPPORT	1						
50	31790990000	POWER TAKE OFF	1						

TM-ZX290 41047701345A FRAME
PB1030209-01 POWER TAKE OFF

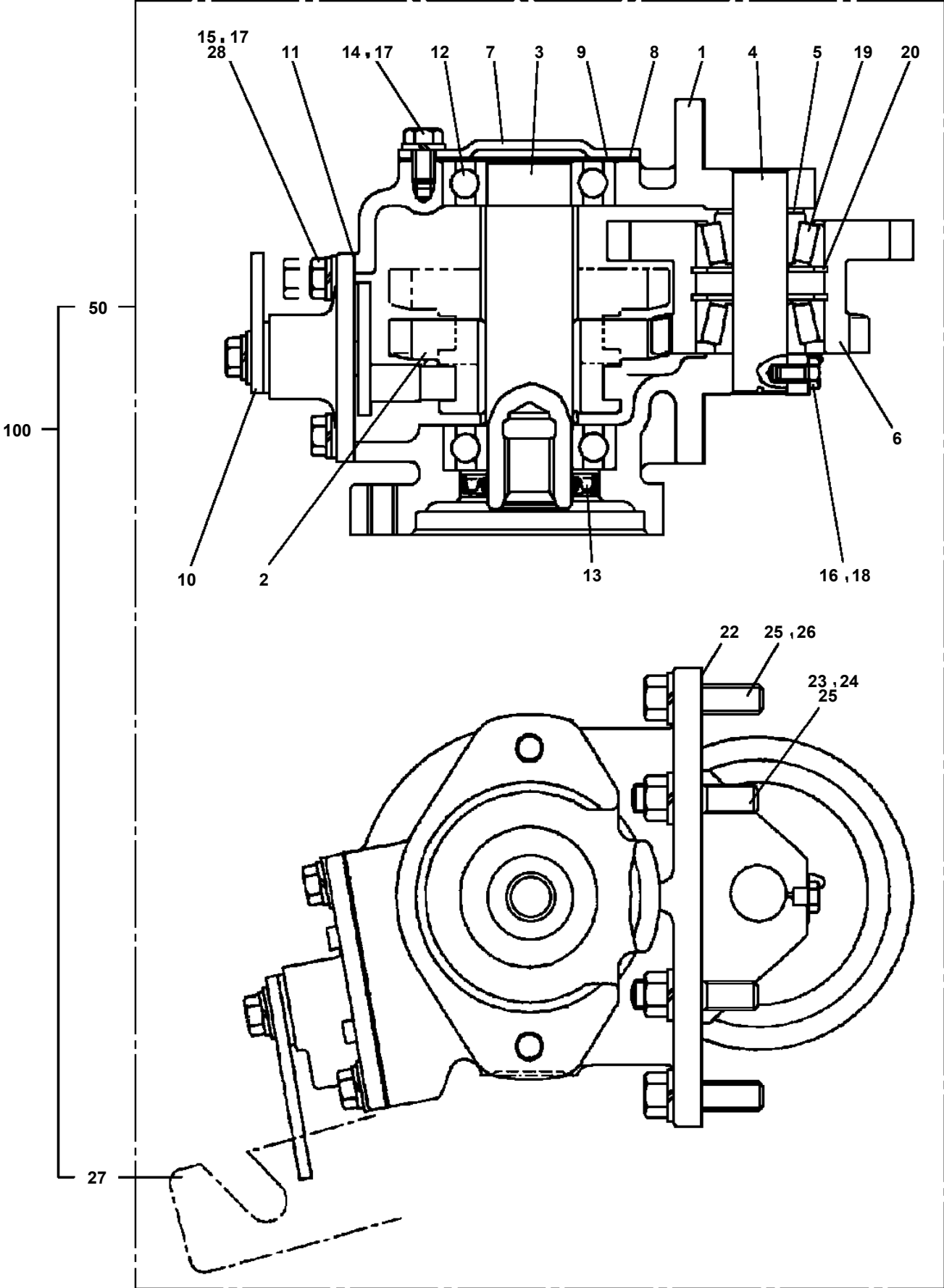

TM-ZX290 41047701345A FRAME
PB1030222-00 POWER TAKE OFF

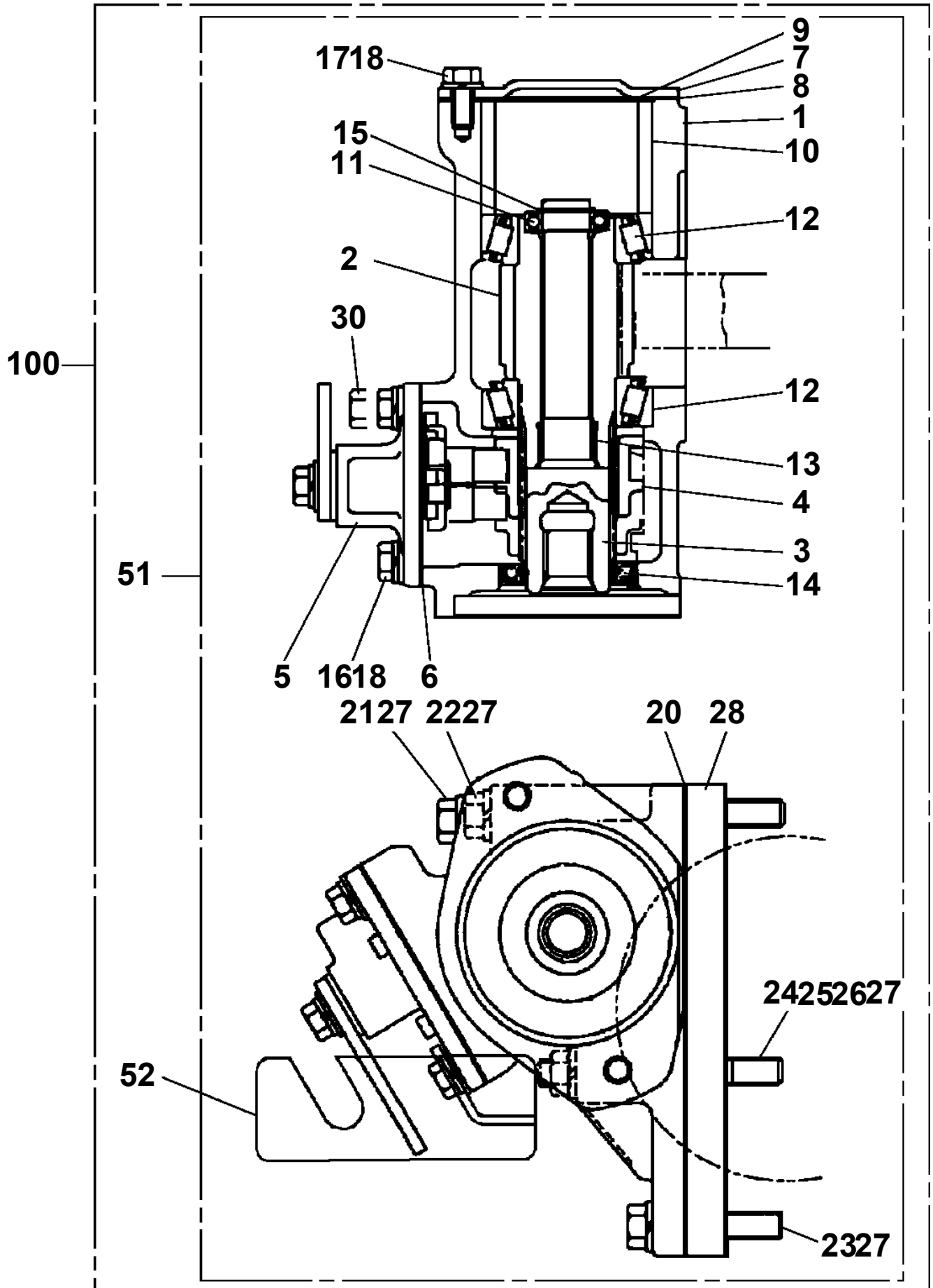

TM-ZX290 41047701345A FRAME
PB1030228-00 POWER TAKE OFF

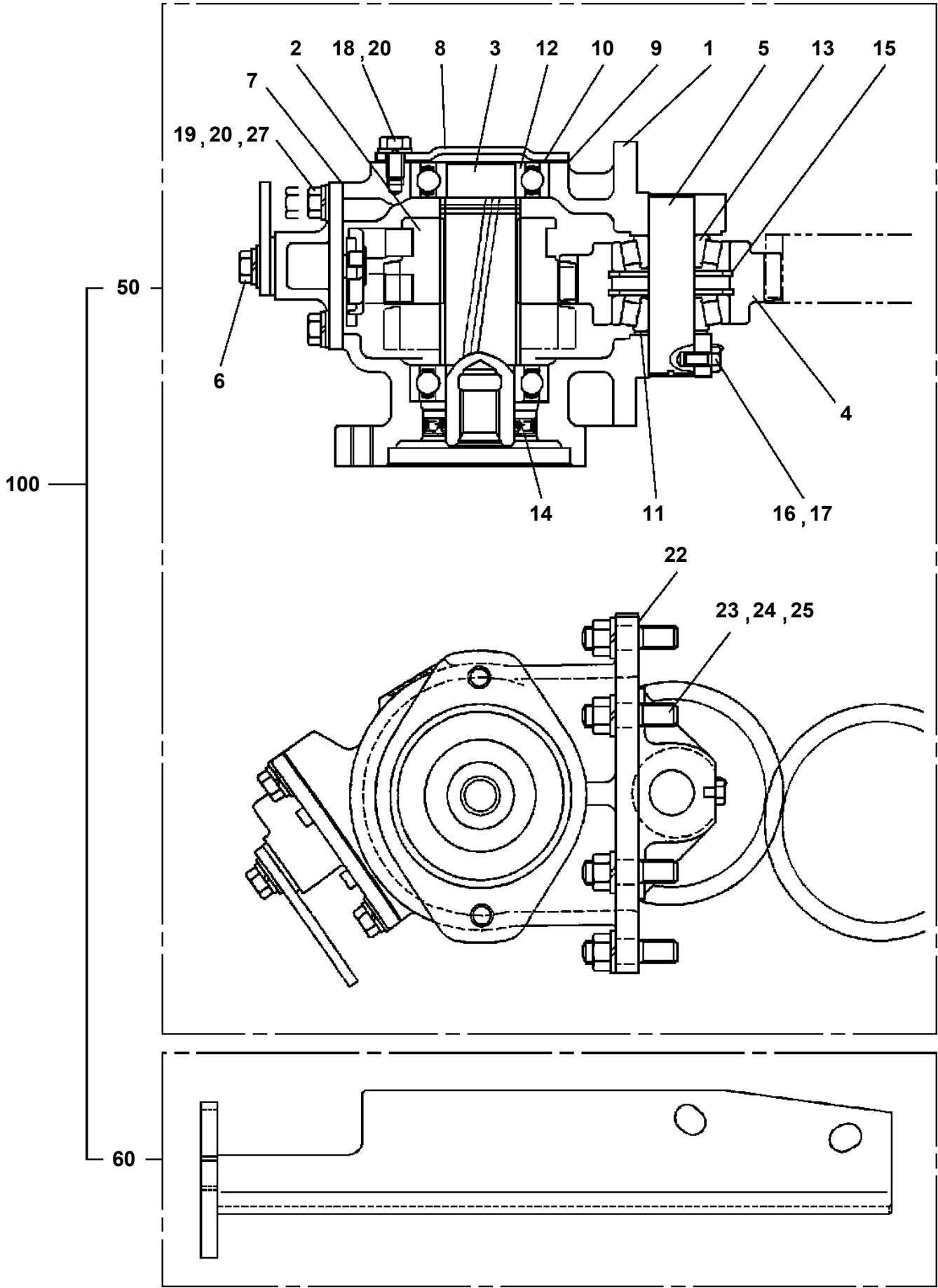

TM-ZX290 41047701345A FRAME
PB1030235-01 POWER TAKE OFF

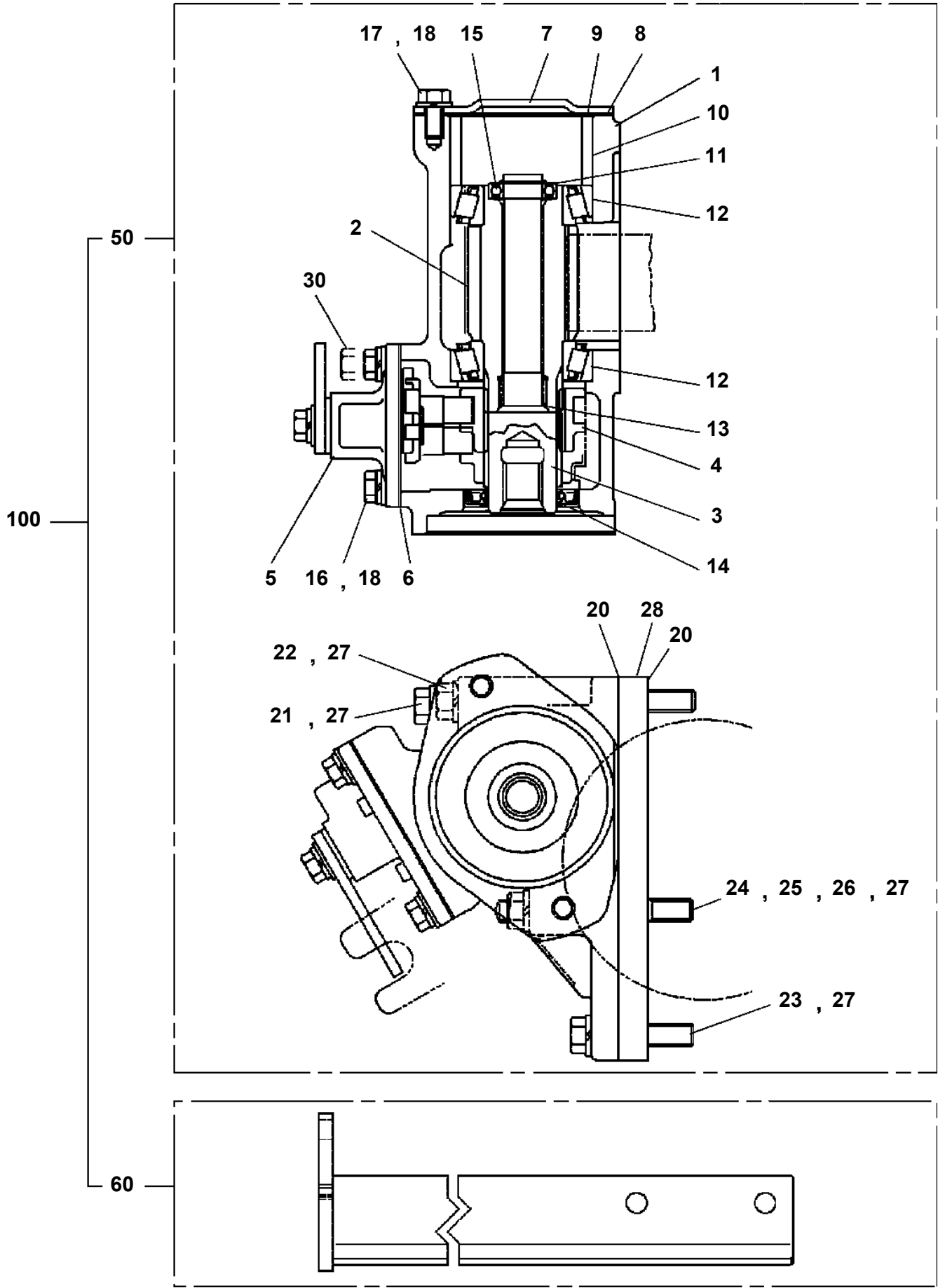

TM-ZX290 41047701345A FRAME

PB1380332-03 POWER SUPPLY (100V POWER SOURCE/1500W)

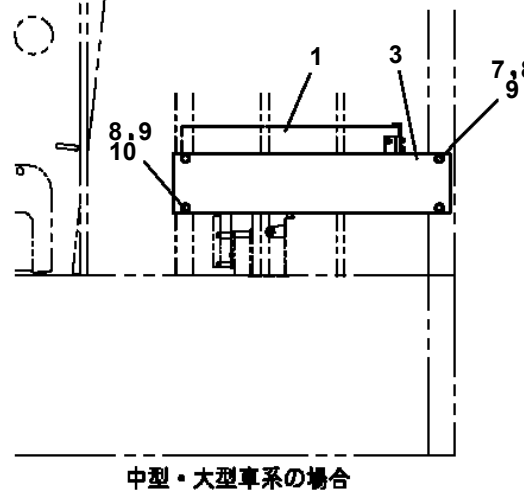
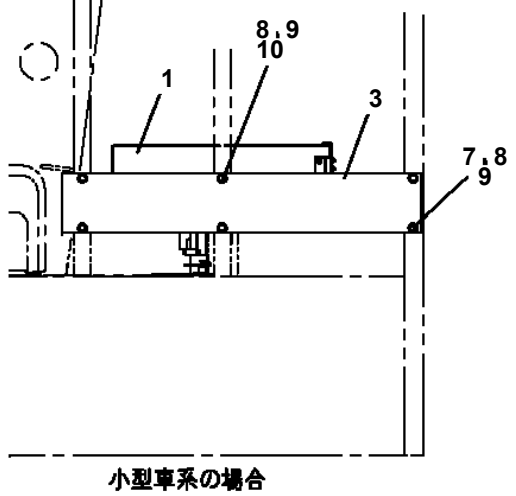
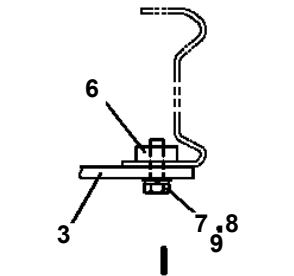
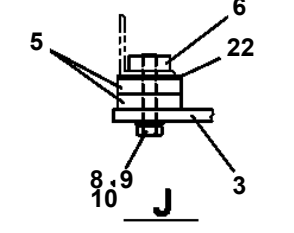
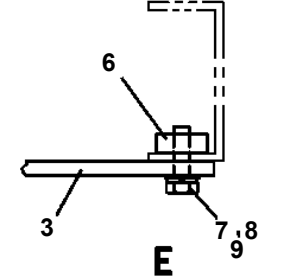
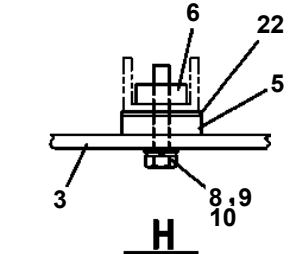
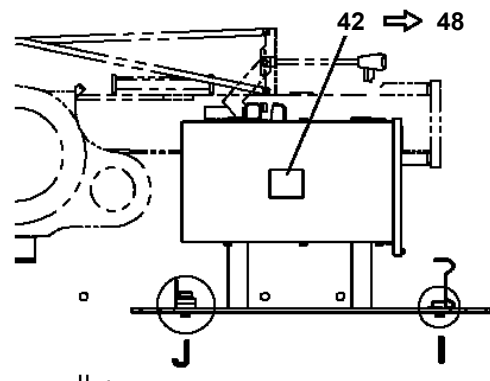
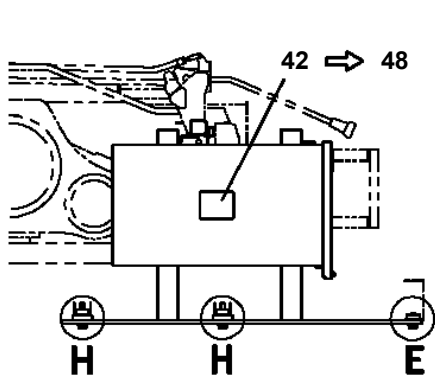
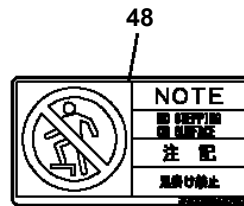
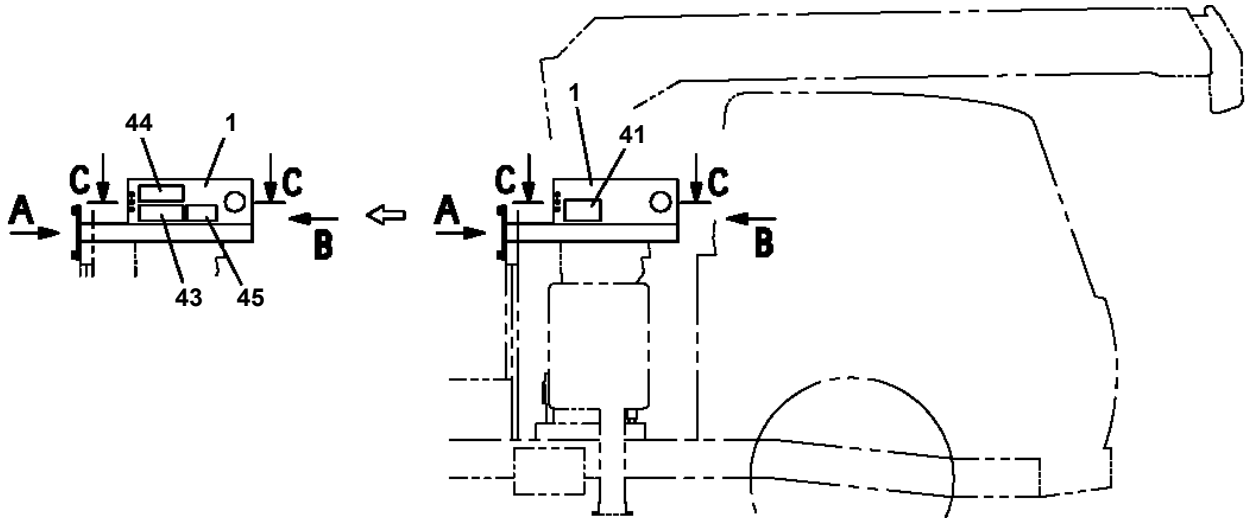

TM-ZX290 41047701345A FRAME

Pos No.	Parts No	Parts Name	Qty	Unit	Technical Data	Serial No (Start)	Serial No
1	42474201000	BLOCK	4		355X355,H=80		
10	31506350000	BLOCK (4 PIECE SET:PLATE,355X355,H=80)	1				

**TM-ZX290 41047701345A FRAME
PC1030301-03 CYLINDER,JACK (REAR OUTRIGGER)**

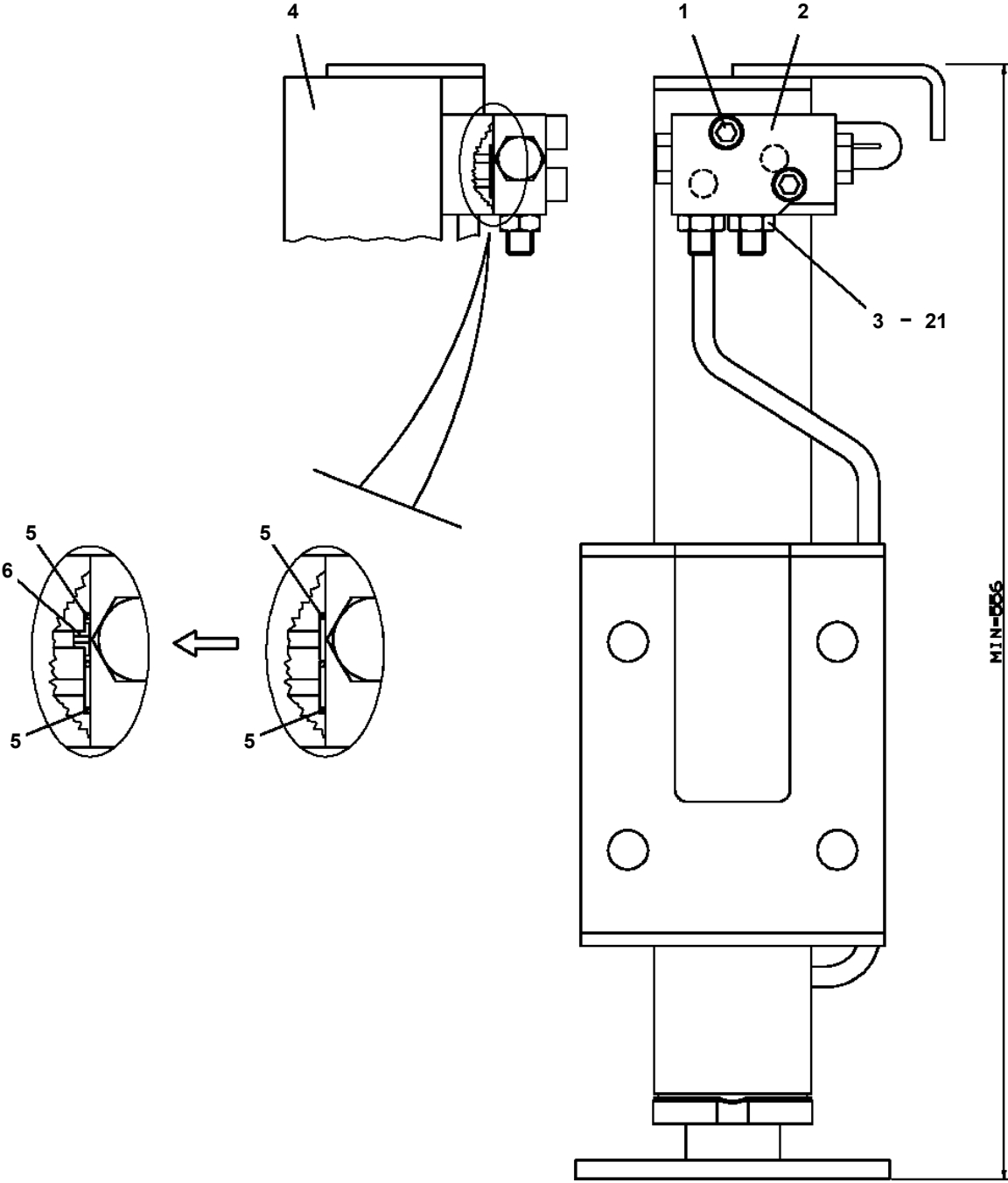

**TM-ZX290 41047701345A FRAME
PC5570231-00 COVER ASSY (SWITCH PANEL)**

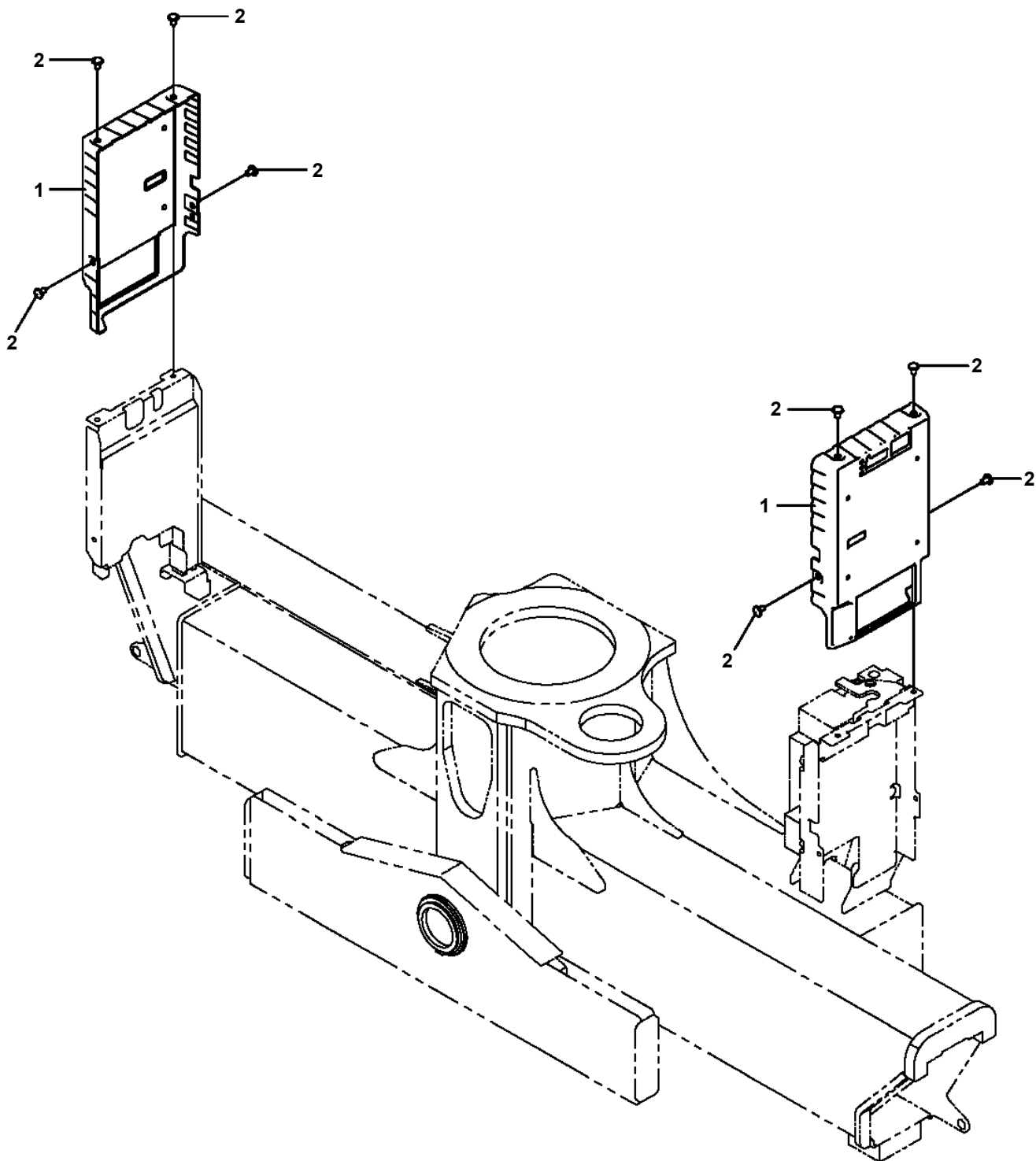

注 意：本図は参考用に掲載しており、形状などは実機と異なります。

NOTE: THE ABOVE FIGURE IS FOR REFERENCE AND MAY DIFFER FROM THE ACTUAL APPEARANCE OF YOUR MACHINE.

TM-ZX290 41047701345A FRAME
PD5120001-00 DETECTOR ASSY,MOMENT

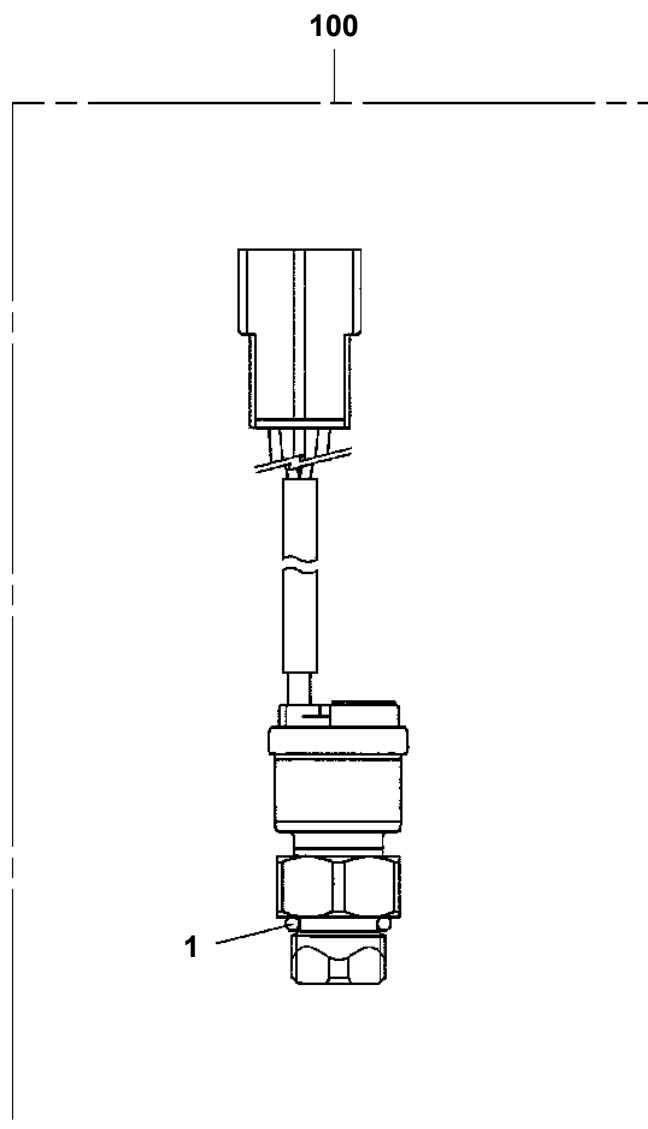

**TM-ZX290 41047701345A FRAME
PE5021233-03 ELEC.ASSY**

ZX290, 260の場合は不要 ZX260の場合は不要

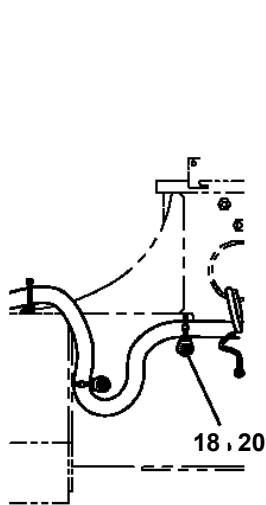
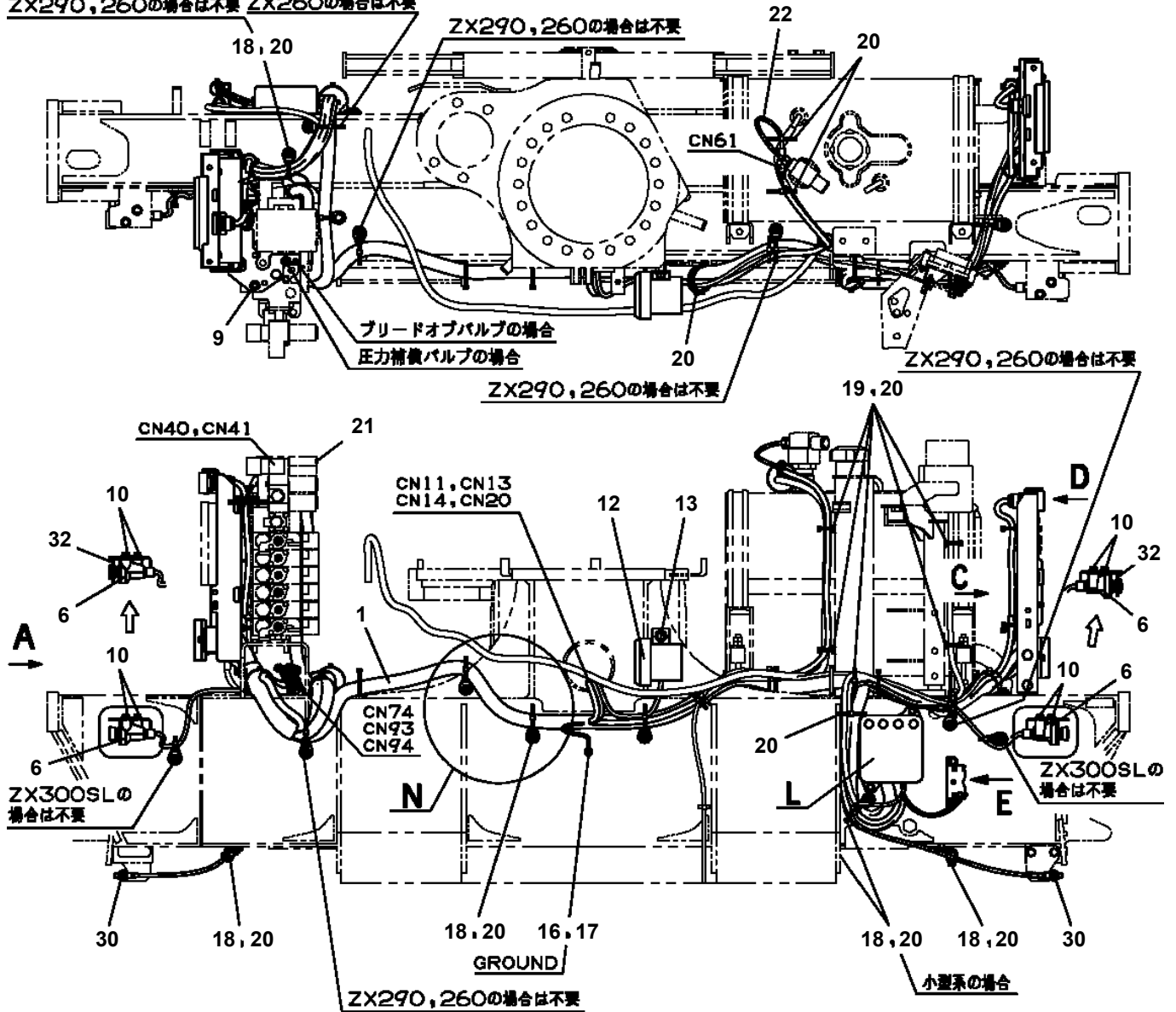

N
小型系の場合

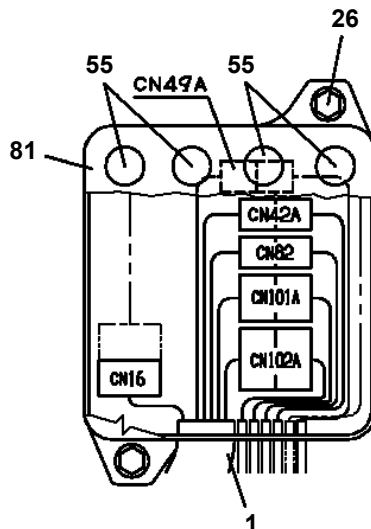

L

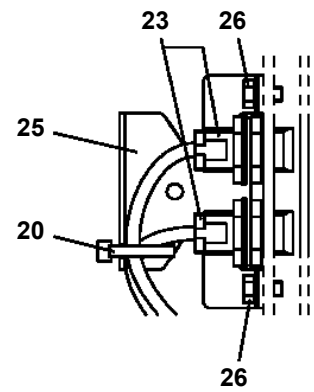

E

**TM-ZX290 41047701345A FRAME
PE5021331-00 ELEC.ASSY**

ハイセンASSY (ソウシンキオキワスレケイホウソウチ)
ELEC.ASSY

置き忘れ警報

符号	日本語名称	英語名称	備考
1	ハイセンASSY	ELEC.ASSY	車両部

適用製造番号によっては取り付けがないものもあります。

MACHINES OF SOME SERIAL NO. ARE NOT EQUIPPED WITH THESE PARTS.

TM-ZX290 41047701345A FRAME
PE5021336-00 ELEC.ASSY (POST/HEAD BULB)

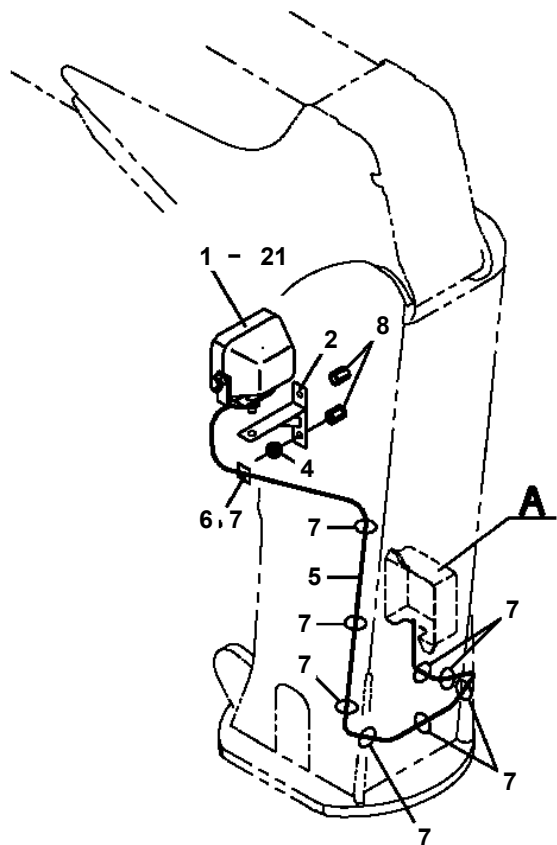

N仕様の場合 (ZX250を除く)

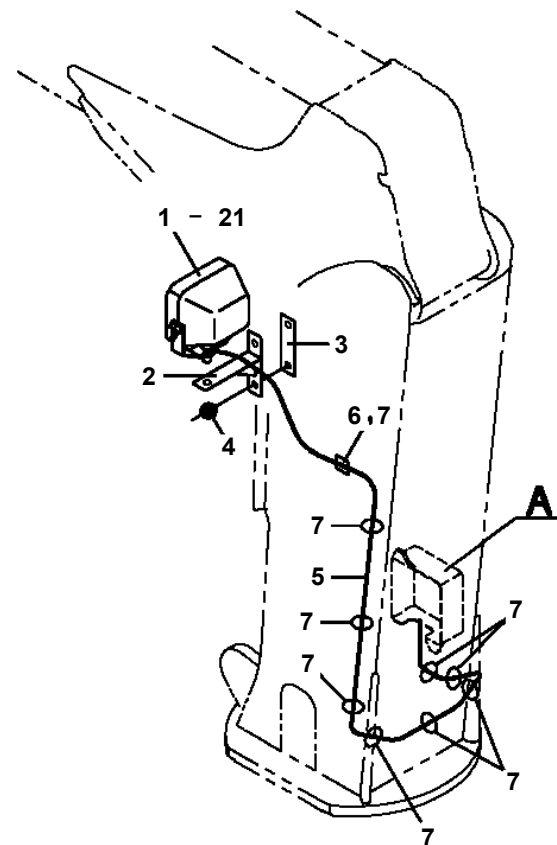

非N仕様の場合

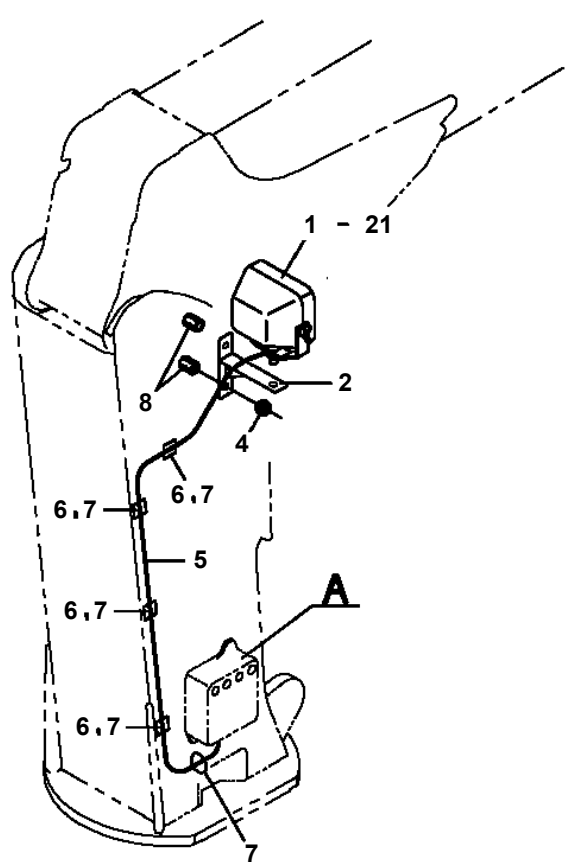
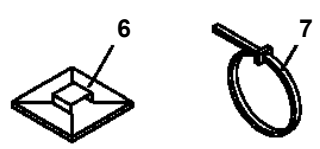
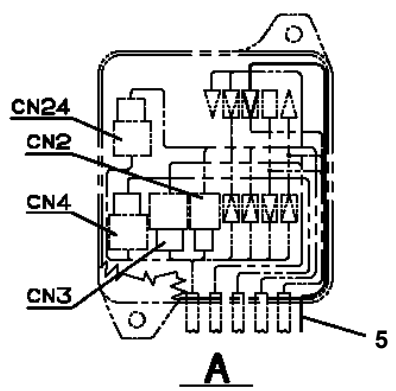

N仕様の場合 (ZX250のみ)

TM-ZX290 41047701345A FRAME
PE5021342-00 ELEC.ASSY

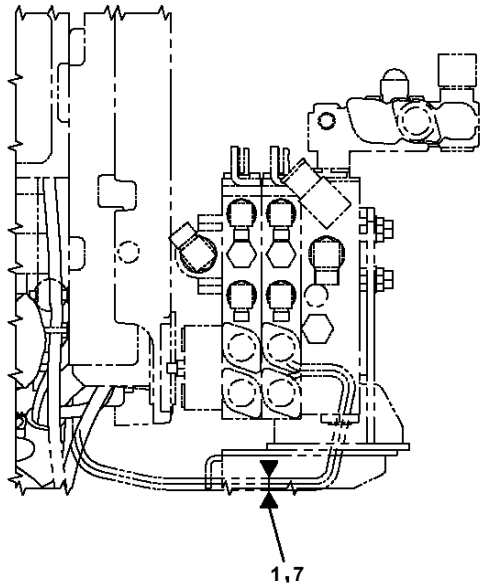

(ZX250, 260)

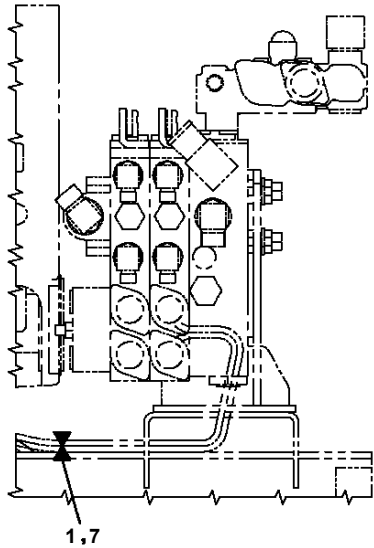

(ZX290)

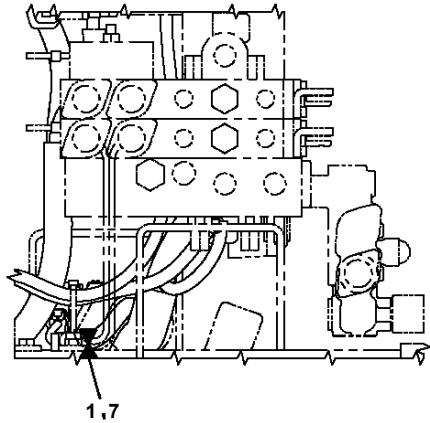

(ZX300, 360)

TM-ZX290 41047701345A FRAME

Pos No.	Parts No	Parts Name	Qty	Unit	Technical Data	Serial No (Start)	Se
1	(*****)	ELEC.ASSY	1				
2	(*****)	ROLLER ASSY (FOR OVER-UNWINDING DETECTOR)	1				
3	(*****)	INDICATOR ASSY	1				

TM-ZX290 41047701345A FRAME
PE5021401-00 ELEC.ASSY

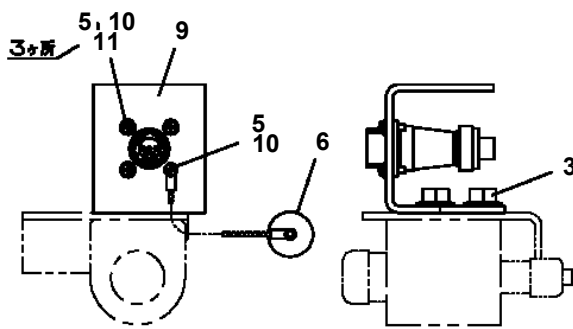
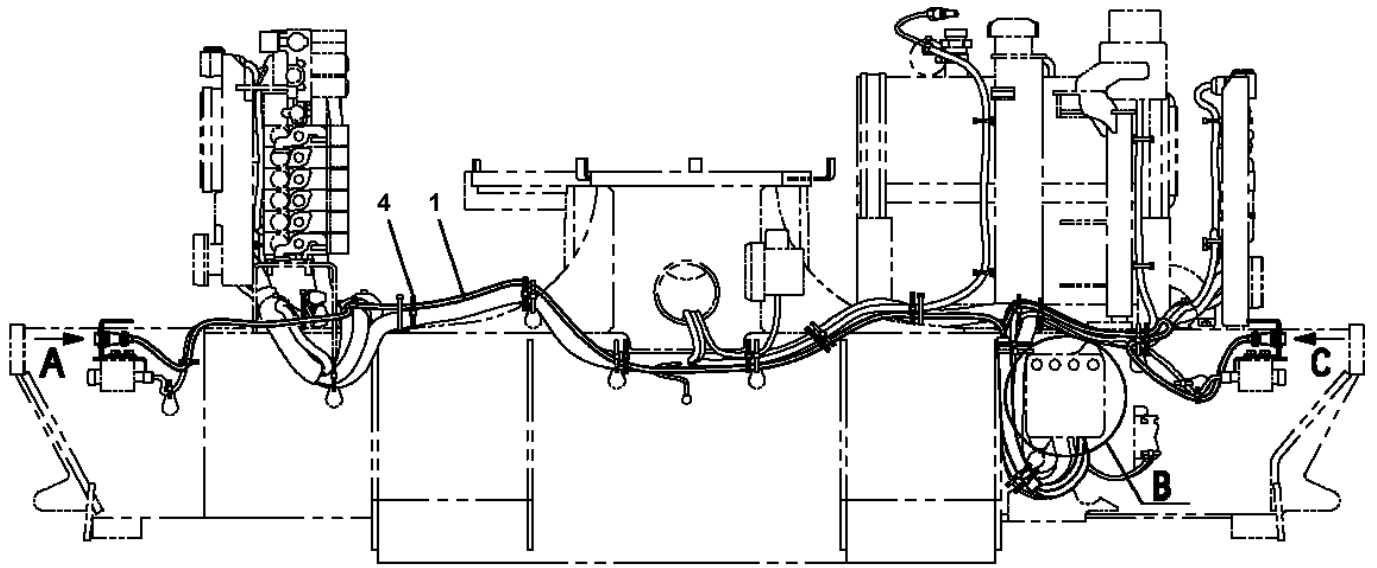

ZX300/360SL 以外の場合

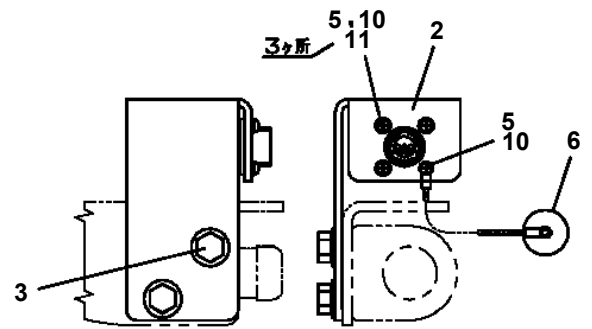

ZX300/360SL の場合

A

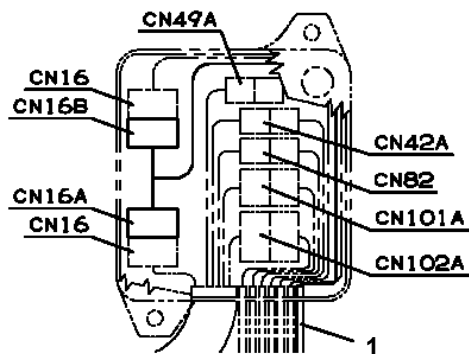

B

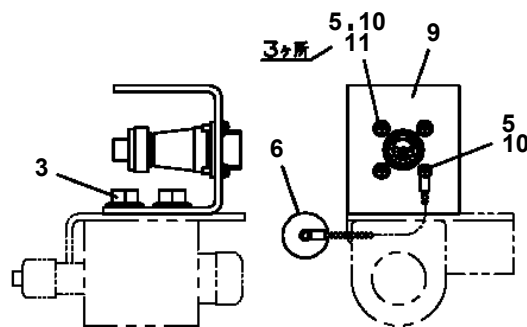

ZX300/360SL 以外の場合

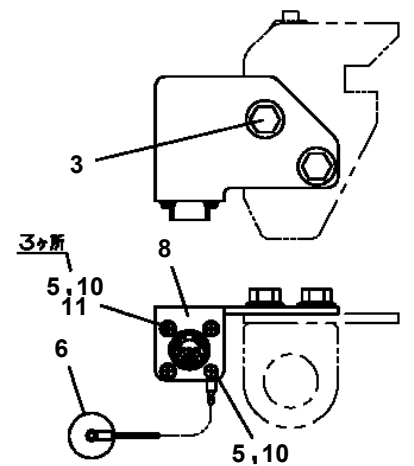

ZX300/360SL の場合

C

TM-ZX290 41047701345A FRAME
PF1010224-02 WINCH

200

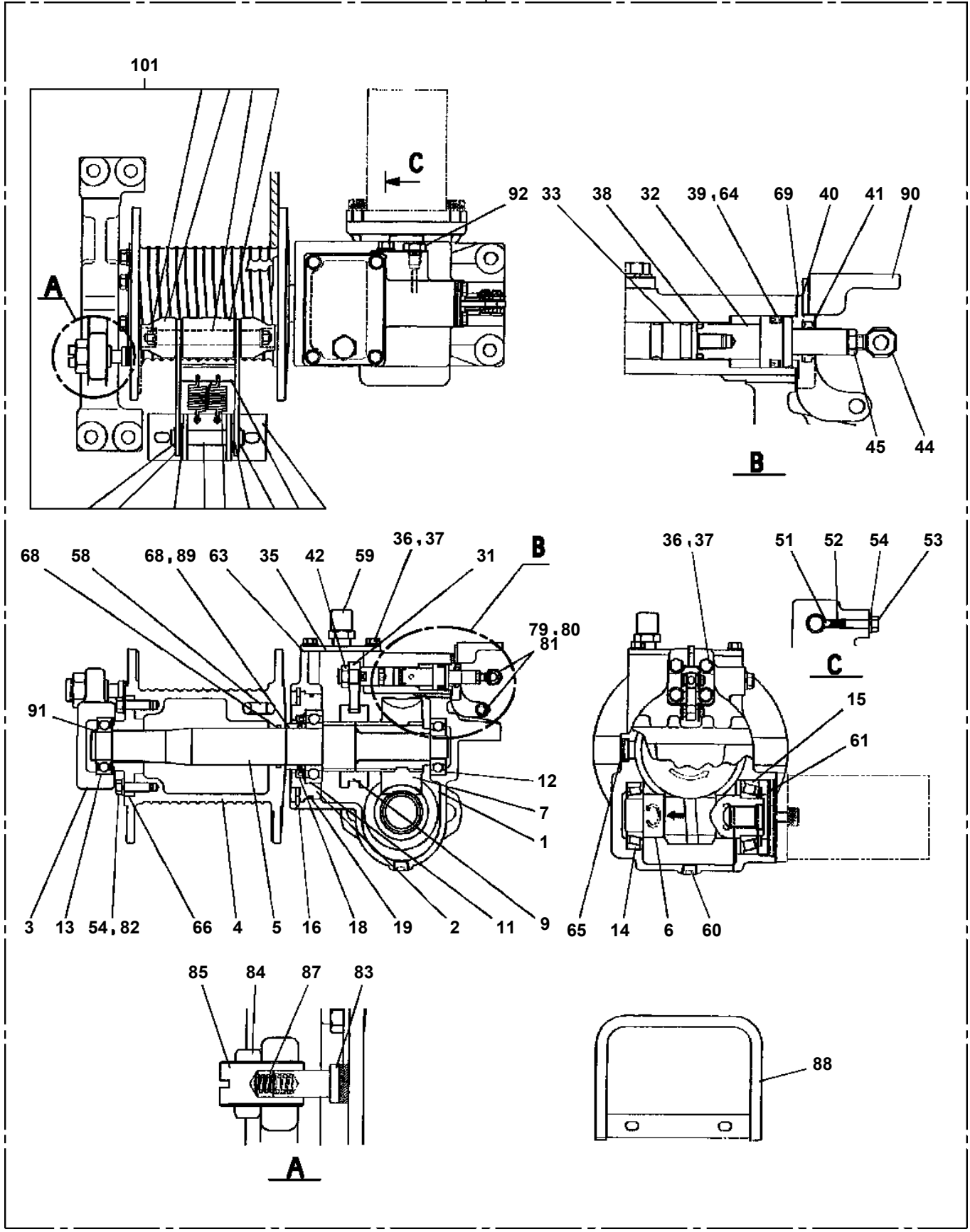

TM-ZX290 41047701345A FRAME
PF1080288-00 SUPPORT

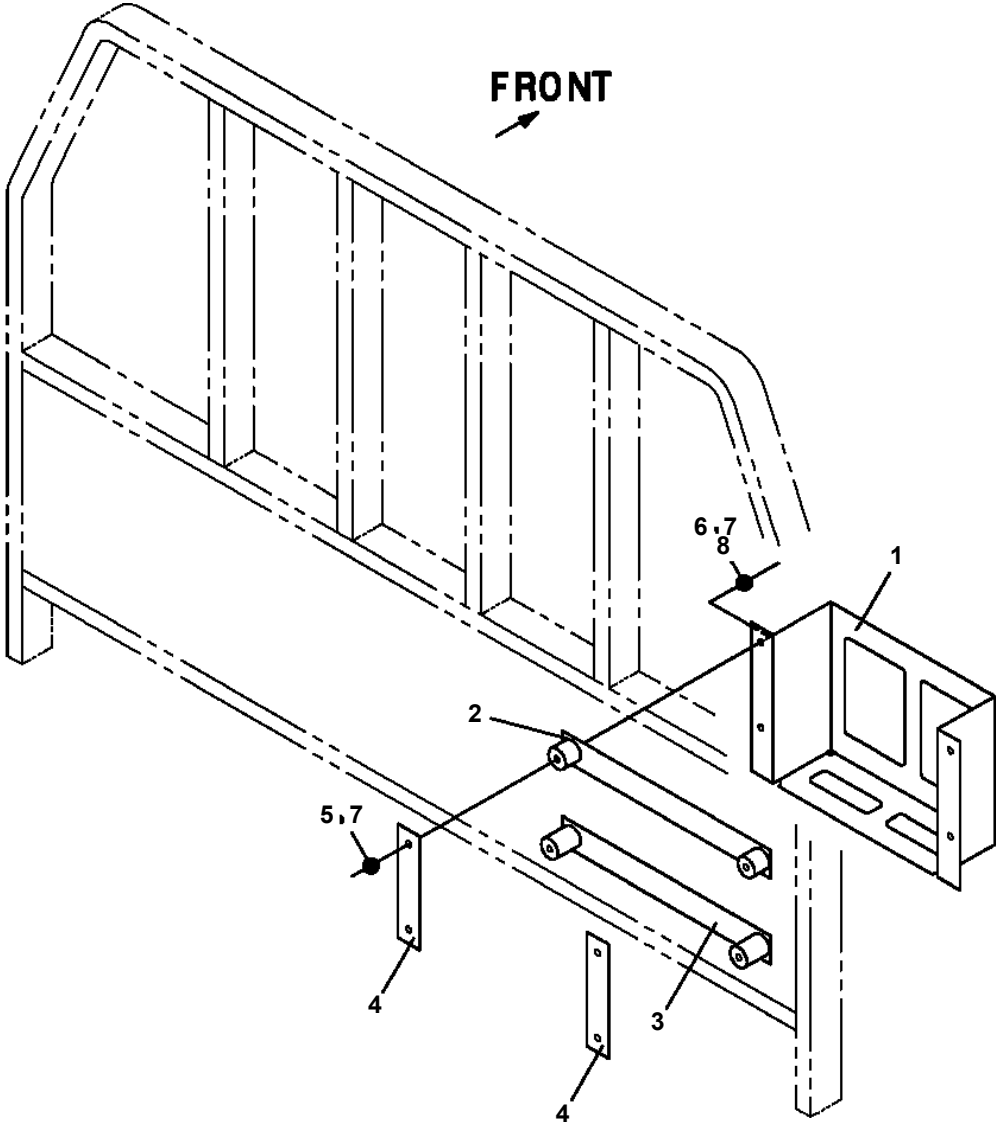

TM-ZX290 41047701345A FRAME

Pos No.	Parts No	Parts Name	Qty	Unit	Technical Data	Serial No (Start)	Serial No (End)	Rema
1	37001500000	BOLT	1					
2	90302041201	WASHER,SPRING	1		12			
3	90303101201	WASHER,PLAIN	1		12			
4	90172110028	BOLT,HEXAGON SOCKET	3		M10X28			
5	90302041001	WASHER,SPRING	3		10			
6	90303071001	WASHER,PLAIN	3		10			
7	36072620000	WINCH (HARTYS)	1					
8	82401800080	PLUG (FOR M8)	2					
9	31310610500	BREATHER,AIR	1					
10	90172108025	BOLT,HEXAGON SOCKET	2		M8X25			
11	90302040801	WASHER,SPRING	6		8			
12	36663100000	MOTOR,HYDRAULIC (WINCH)	1					
13	91001206000	O-RING	1		1A G60			
14	37000137550	PIN	1					
15	90186210014	BOLT,FLANGE	2		M10X14			
16	37000306110	SPACER	1		L=16 TO 16.5			
17	31310391000	COVER	1					
18	31311240100	DRUM,WINCH (HARTYS)	1					
	31311240300	DRUM,WINCH (Y.G.TEC)	1					
19	37002600190	WEDGE	1		8			
20	37000306550	SPACER	1		L=18			
21	90101208020	BOLT	4		M8X20			
22	31311210200	PLATE	1					
23	31311210301	SPACER	4		L=6			
24	31311250200	PLATE	3		T=1			

**TM-ZX290 41047701345A FRAME
PH5031204-00 HARNESS**

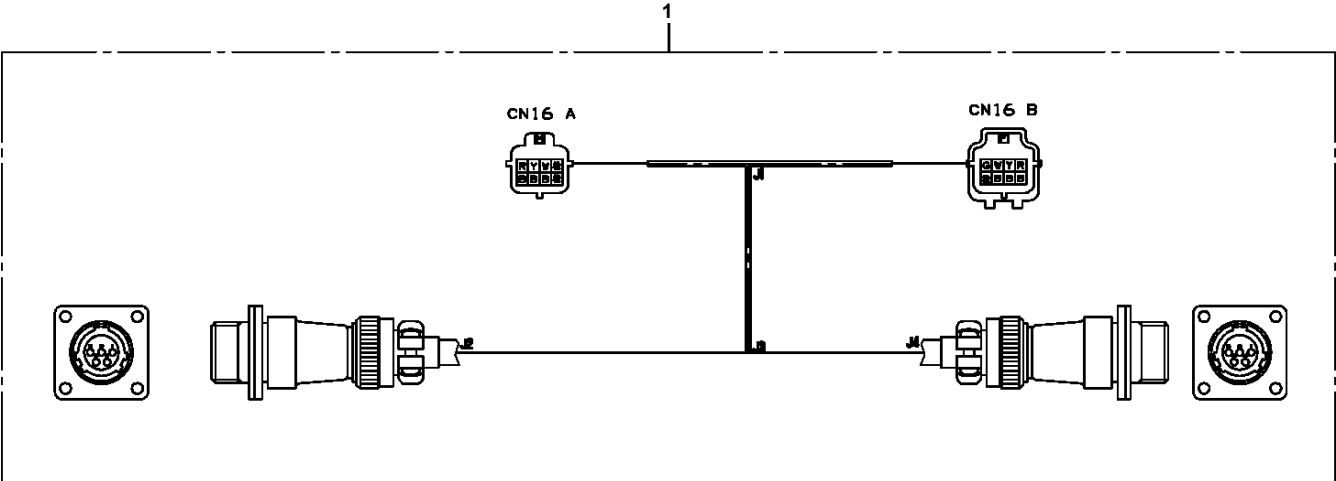

TM-ZX290 41047701345A FRAME
PH5033590-00 HARNESS

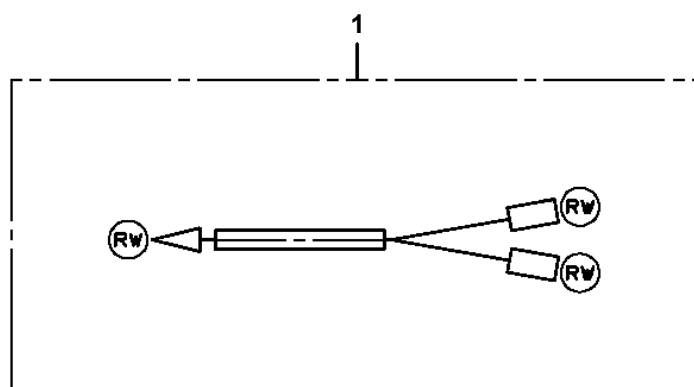

**TM-ZX290 41047701345A FRAME
PH5033870-00 HARNESS**

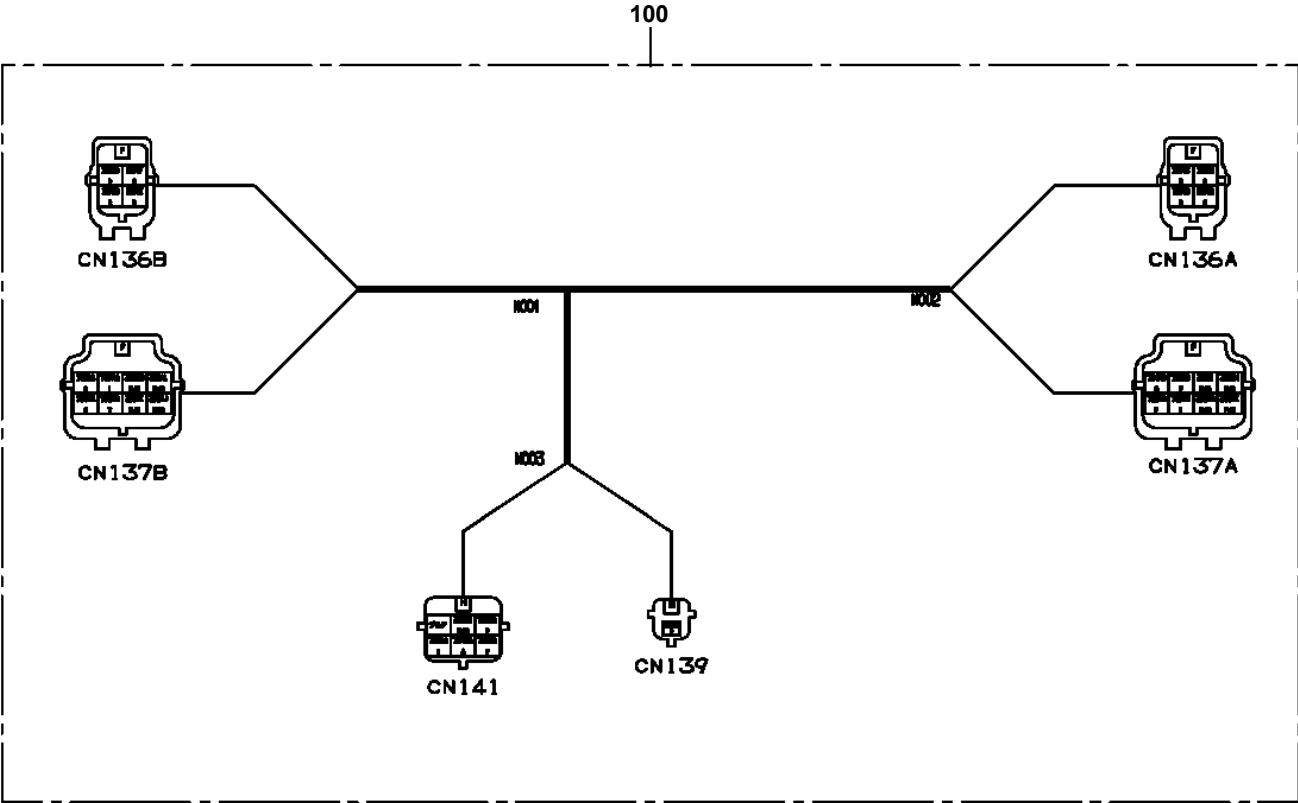

TM-ZX290 41047701345A FRAME
PH5034114-00 HARNESS

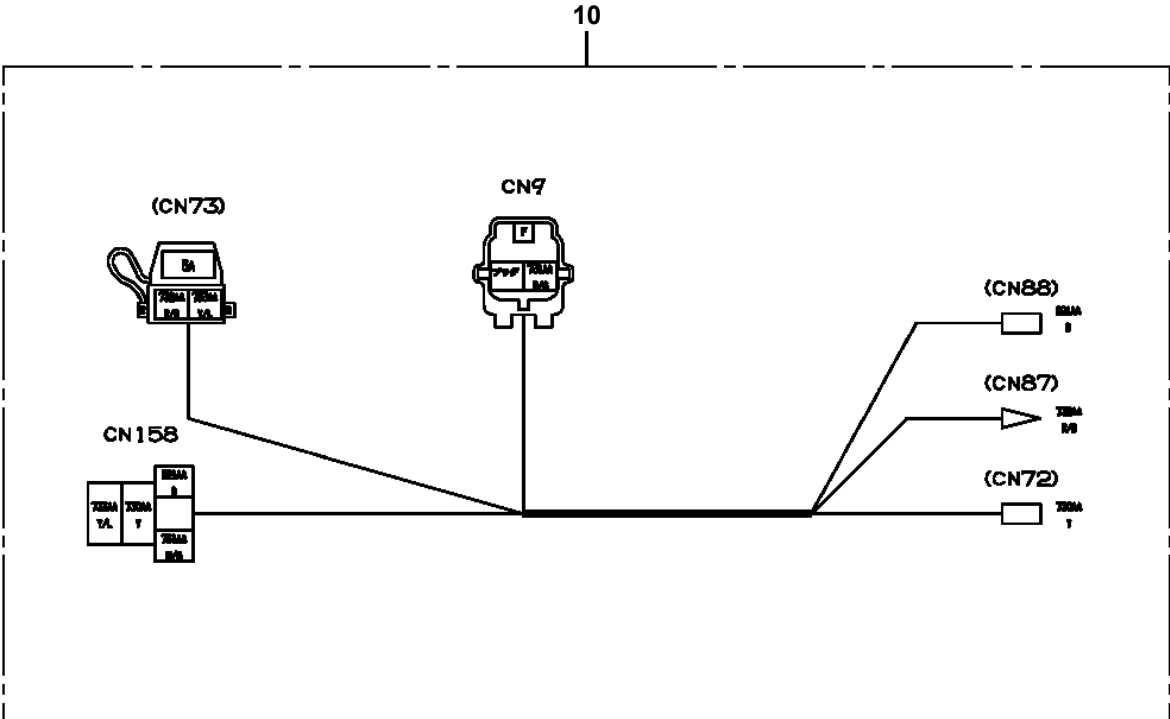

**TM-ZX290 41047701345A FRAME
PH5034359-00 HARNESS**

100

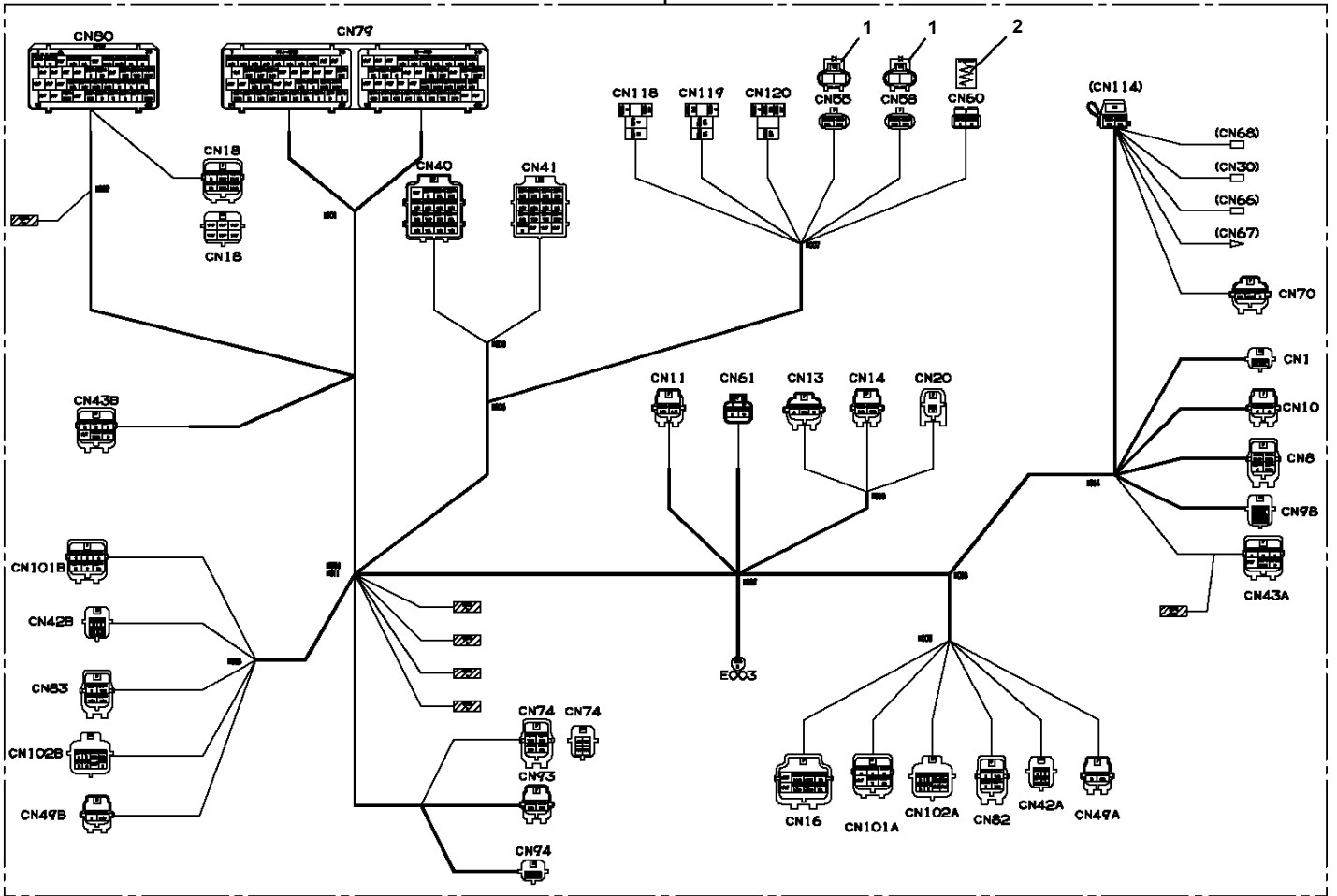

**TM-ZX290 41047701345A FRAME
PI1010152-00 MOTOR, HYDRAULIC (WINCH)**

50

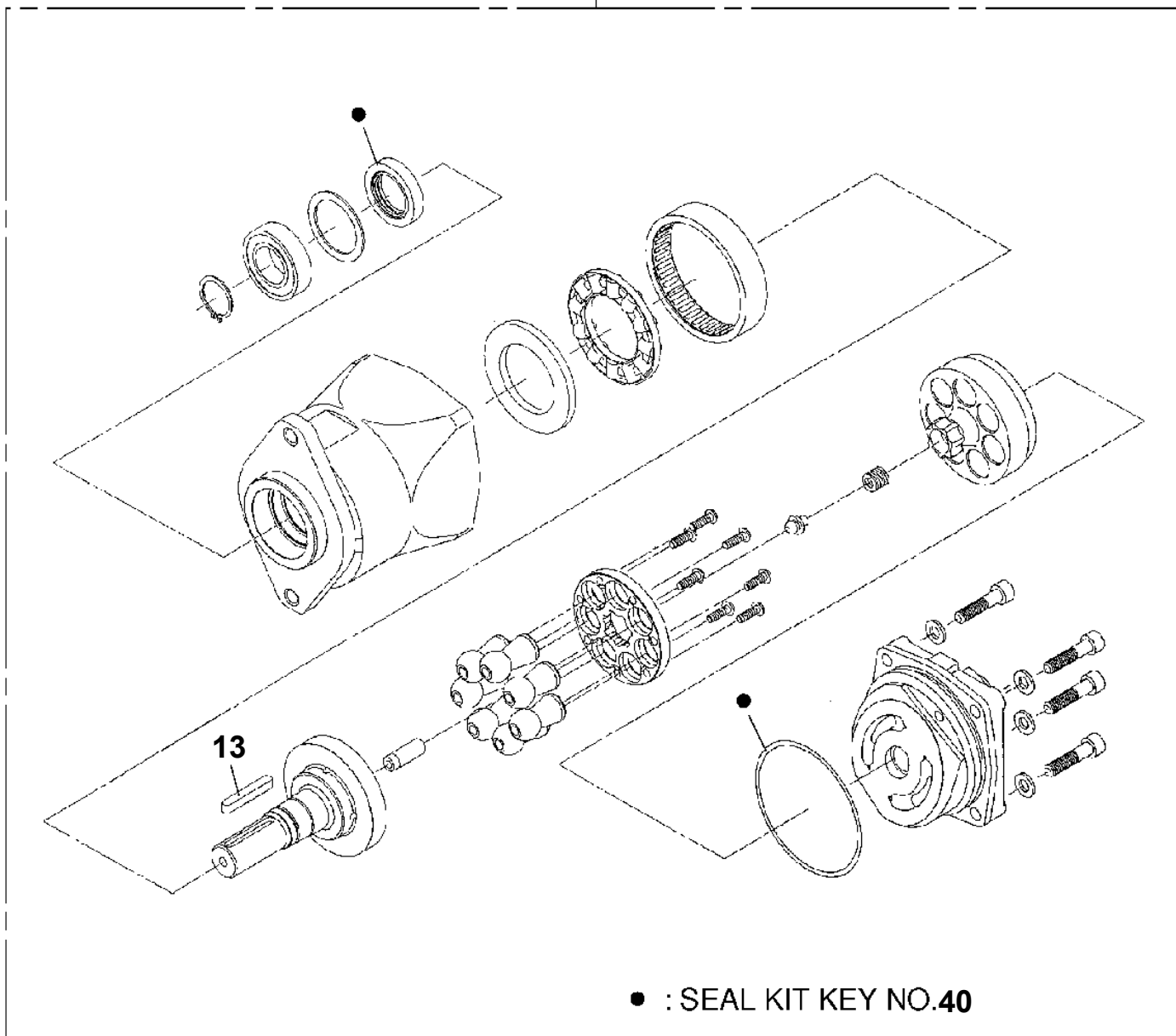

CLICK HERE TO **DOWNLOAD** THE COMPLETE MANUAL

- Thank you very much for reading the preview of the manual.
- You can download the complete manual from: www.heydownloads.com by clicking the link below



- Please note: If there is no response to CLICKING the link, please download this PDF first and then click on it.

CLICK HERE TO **DOWNLOAD** THE COMPLETE MANUAL

**TM-ZX290 41047701345A FRAME
PI1280051-00 VALVE,PILOT CHECK**

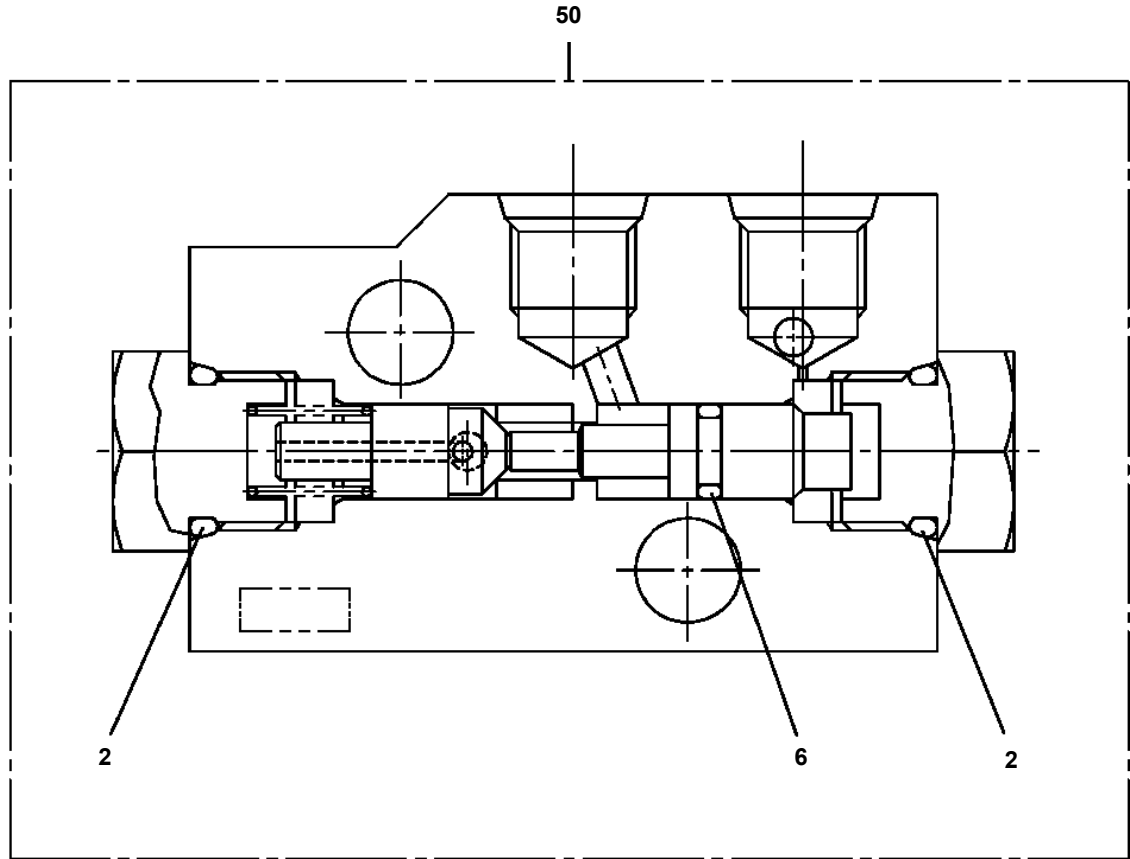

TM-ZX290 41047701345A FRAME
PI5200001-00 INDICATOR

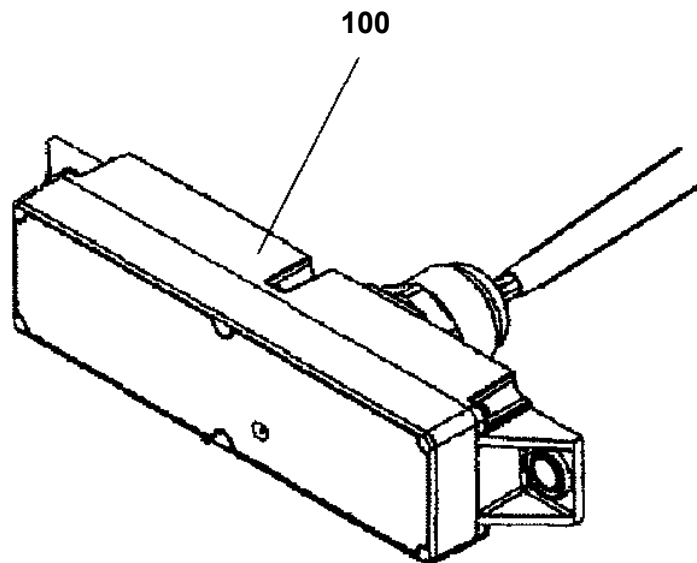

TM-ZX290 41047701345A FRAME
PJ5140001-00 JOINT ASSY,SELF SEAL

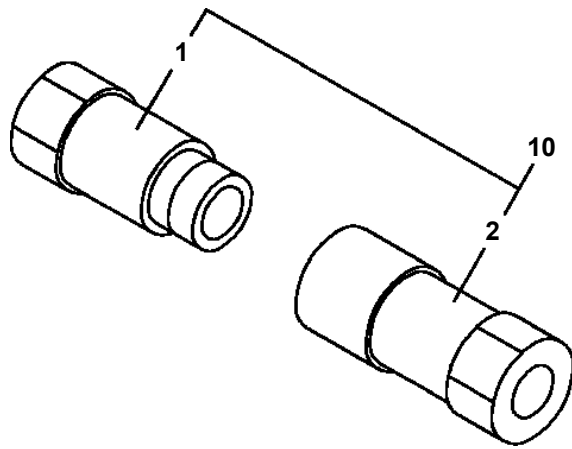

**TM-ZX290 41047701345A FRAME
PL1010734-01 OPE.ASSY,CONT.VALVE (POWER SUPPLY)**

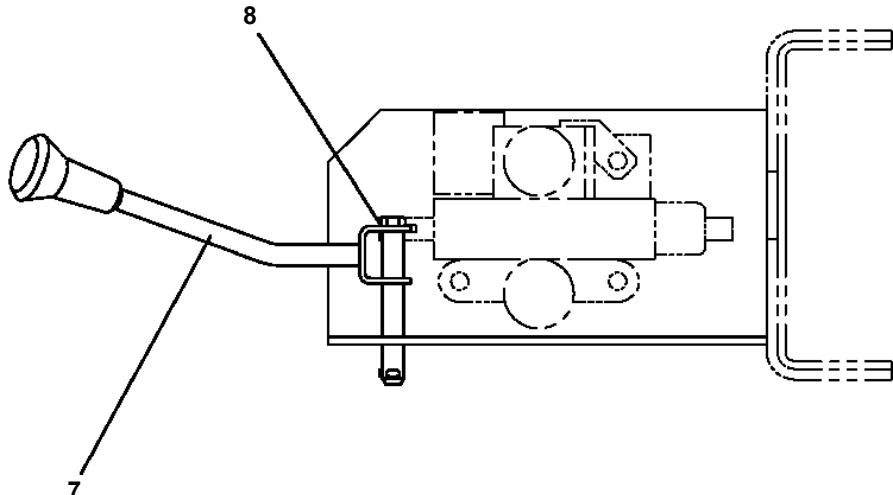
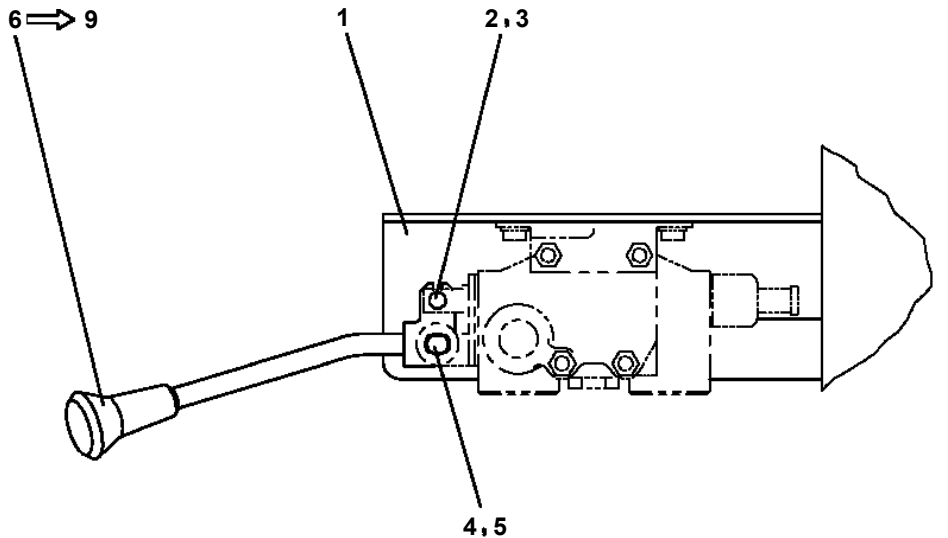

TM-ZX290 41047701345A FRAME
PL5020225-00 LAMP ASSY (POST/24V-60W)

ランプ ASSY (ホスト/24V-60W)
LAMP ASSY (POST/24V-60W)

ポスト取付けタイプ
ランプ仕様：24V-60W

符号	日本語名称	英語名称	備考
2	ハイセンASSY	ELEC. ASSY	ホスト部
3	ハイセンASSY	ELEC. ASSY	ホスト部 (ハット球60W)

適用製造番号によっては取り付けがないものもあります。

MACHINES OF SOME SERIAL NO. ARE NOT EQUIPPED WITH THESE PARTS.

**TM-ZX290 41047701345A FRAME
PL5190008-00 LEVER ASSY**

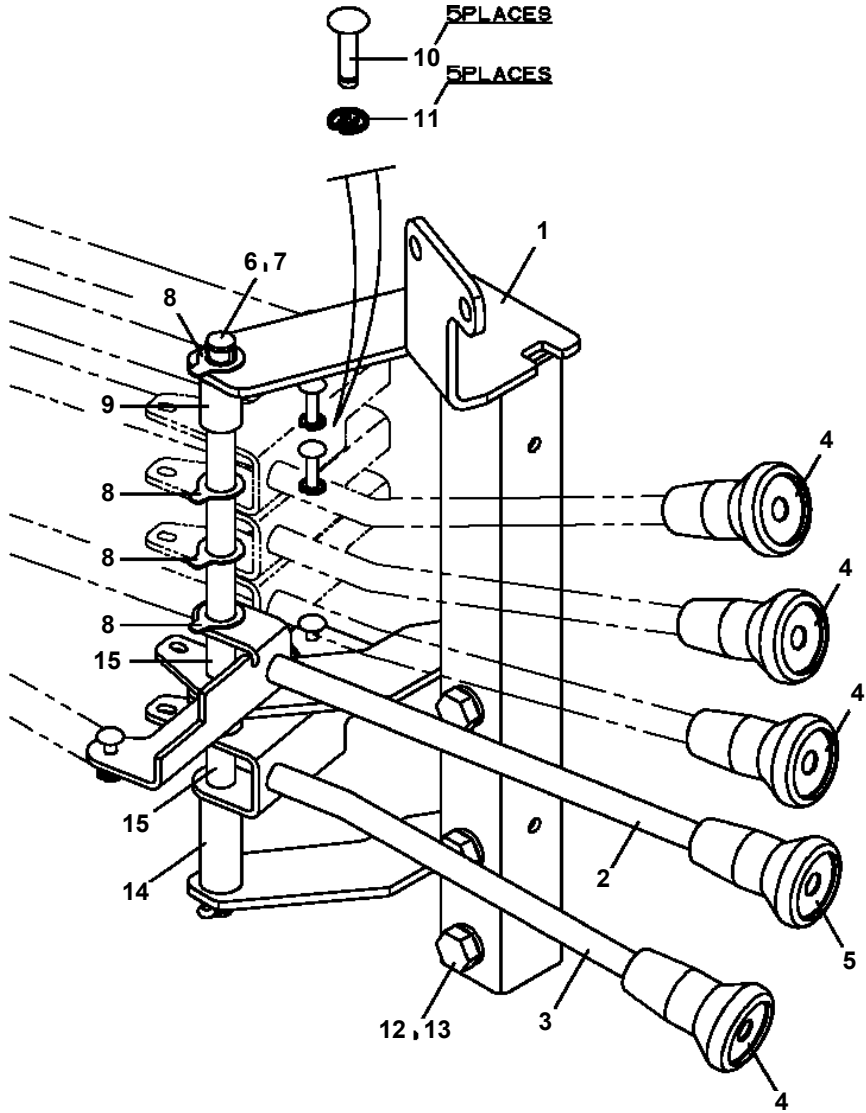

TM-ZX290 41047701345A FRAME
 PM5150697-01 MODIFICATION ASSY (PLANKING CASE:FOR WHEEL BASE)

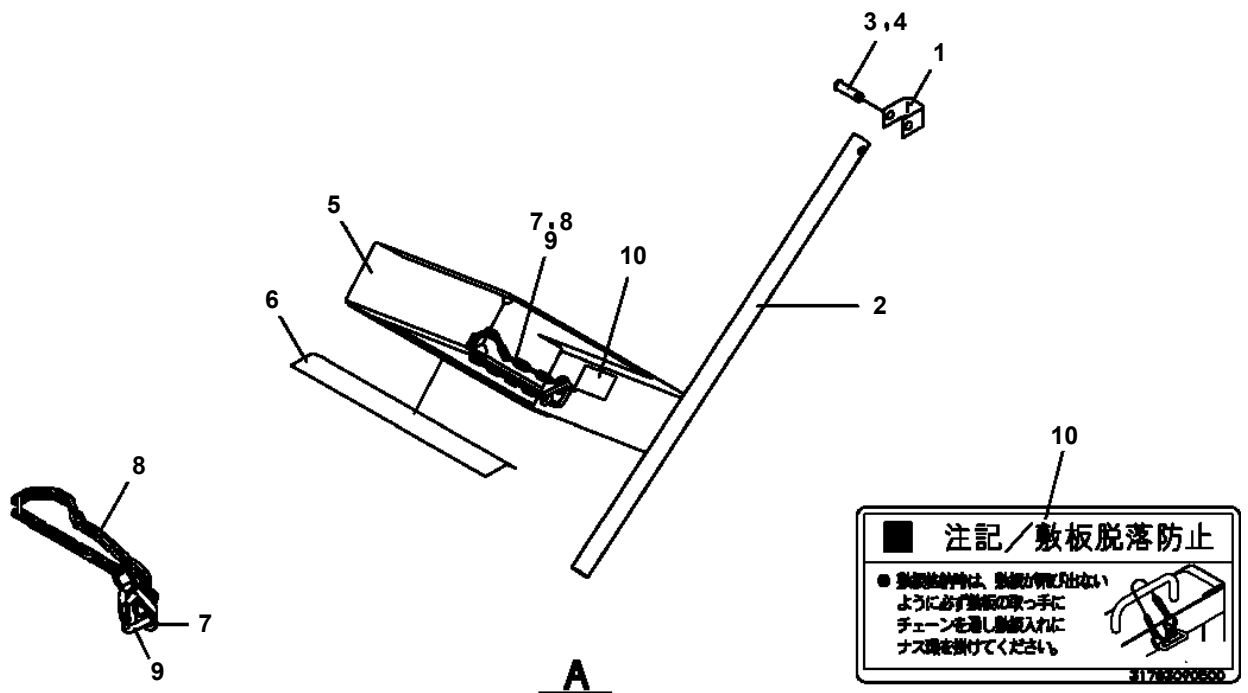
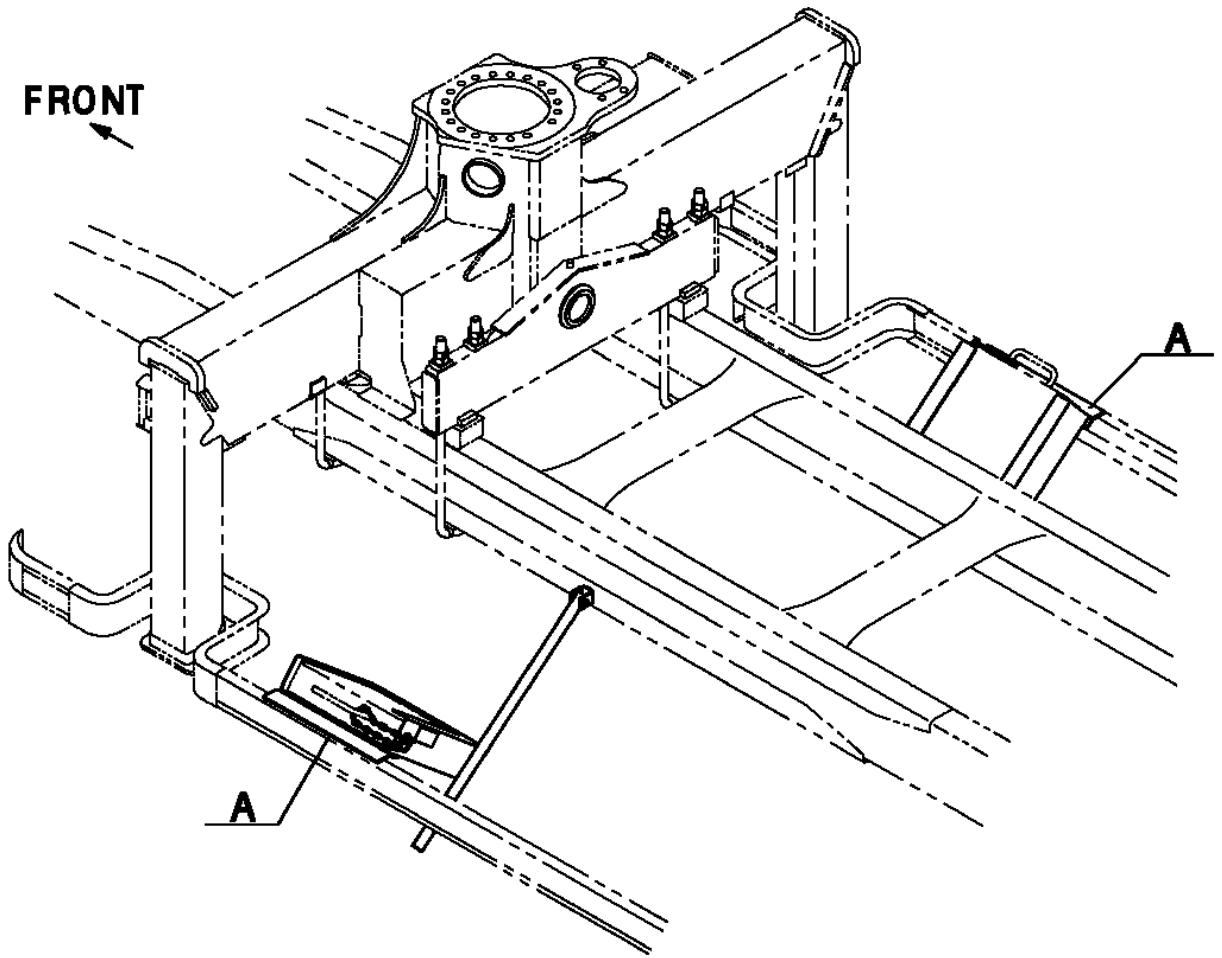

KEY NO.1~NO.10のセットNO.はNO. 100 です。
 THE NO.OF THE KEY SET OF NO.1 TO NO.10 IS NO. 100 .

**TM-ZX290 41047701345A FRAME
PN1014687-03 ELEC.ASSY (UPPER/WORKING LAMP)**

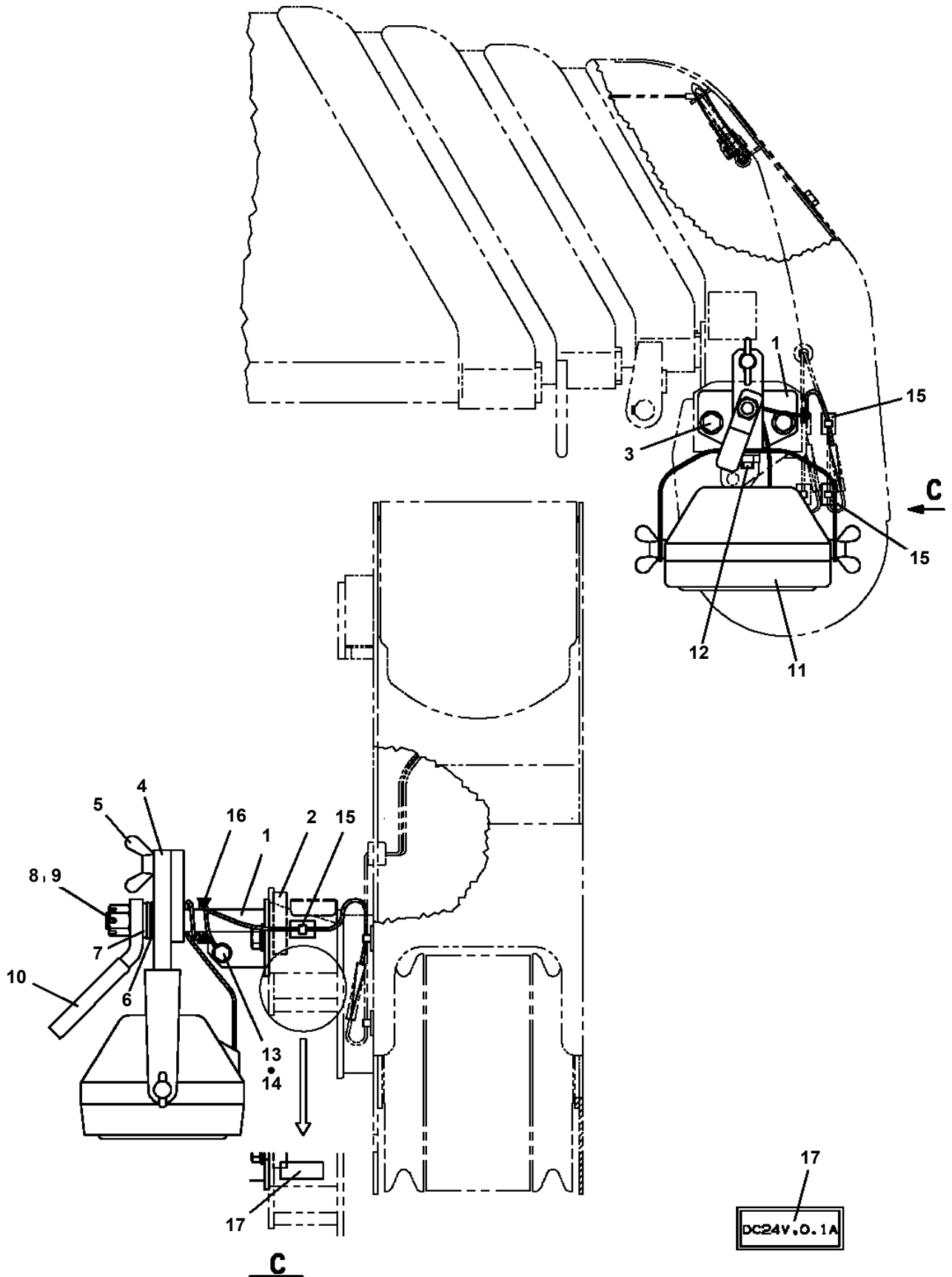

注 意：本図は参考用に掲載しており、形状などは実機と異なります。

NOTE: THE ABOVE FIGURE IS FOR REFERENCE AND MAY DIFFER FROM THE ACTUAL APPEARANCE OF YOUR MACHINE.

TM-ZX290 41047701345A FRAME
PN5012017-01 NAME PLATE ASSY (KNOB:U-LAYOUT)

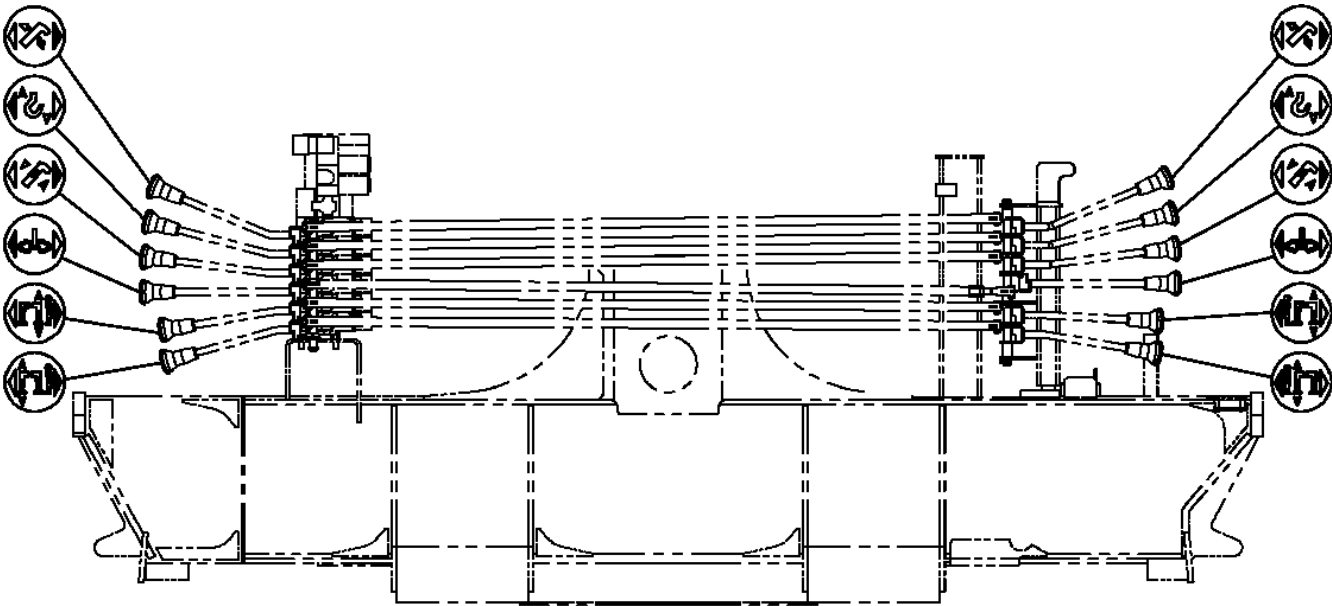

100

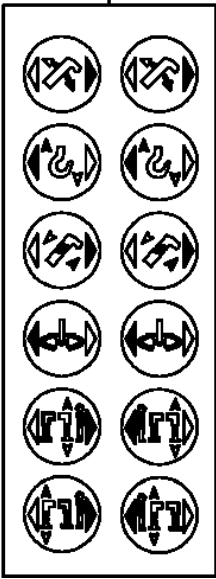

TM-ZX290 41047701345A FRAME
PN5012051-01 NAME PLATE ASSY (FRAME:U-LAYOUT)

ネームプレートASSY (フレーム:Uシヤハイレッツ)
NAME PLATE ASSY (FRAME:U-LAYOUT)

符号	日本語名称	英語名称	備考
1	ネームプレートASSY	NAME PLATE ASSY	ノブ銘板:U社配列 (SL)
4	ネームプレートASSY	NAME PLATE ASSY	タンク油量銘板:共通
5	ネームプレートASSY	NAME PLATE ASSY	フック銘板:共通
6	ネームプレートASSY	NAME PLATE ASSY	O/R注意銘板等
7	ネームプレートASSY	NAME PLATE ASSY	定期自主検査銘板
8	ネームプレートASSY	NAME PLATE ASSY	ノブ銘板 SLジャッキ

適用製造番号によっては取り付けがないものもあります。

MACHINES OF SOME SERIAL NO. ARE NOT EQUIPPED WITH THESE PARTS.

TM-ZX290 41047701345A FRAME
PN5012122-00 NAME PLATE ASSY

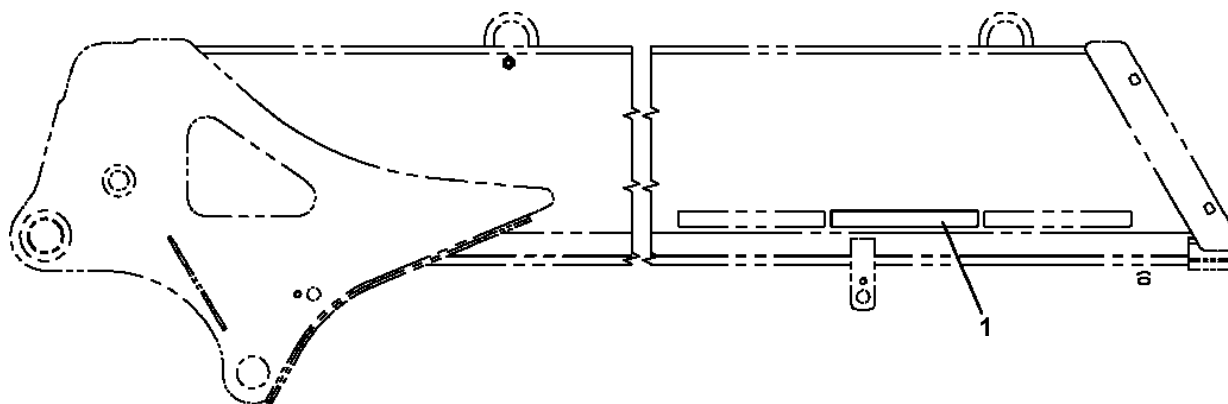

1
ブームジャッキ インターロック装置付

TM-ZX290 41047701345A FRAME
 PN5012165-01 NAME PLATE ASSY (JSAS)

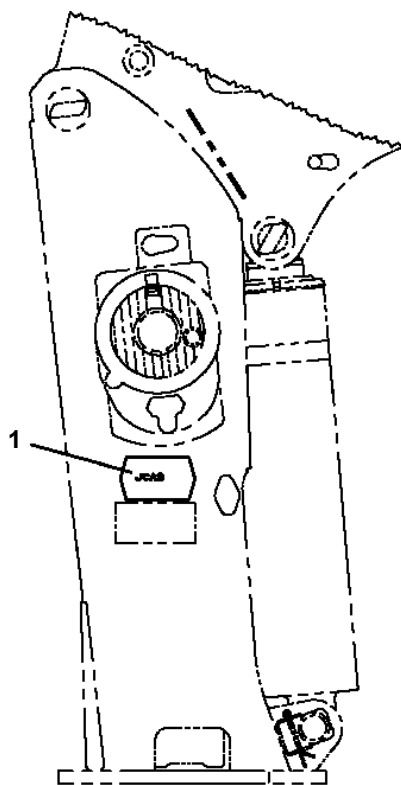

ZX250, ZX260, ZX290
 ZX300, ZX360
 ZS500, ZS580
 ZX500

ポスト側面

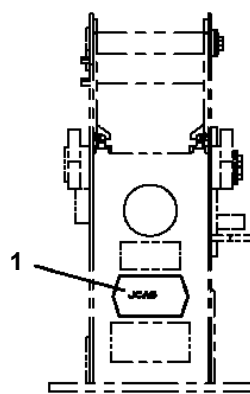

ZS220
 ポスト前面

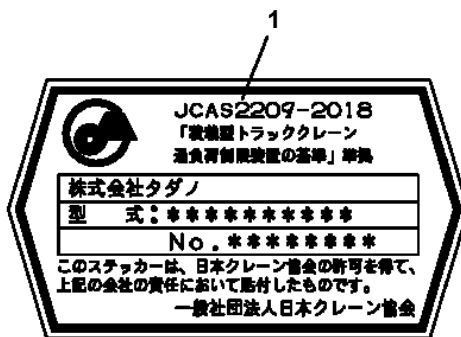

TM-ZX290 41047701345A FRAME
PN5012194-00 NAME PLATE ASSY (NETIS/S-SIZE)

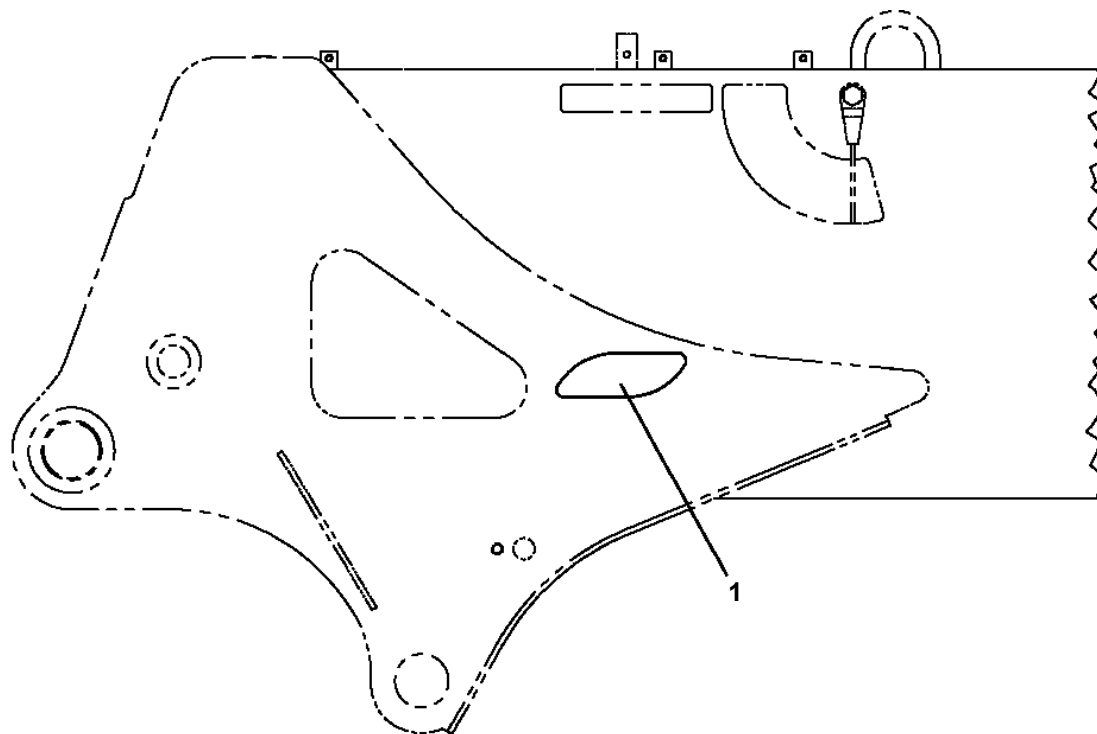

TM-ZX290 41047701345A FRAME
PN5012296-00 NAME PLATE ASSY

1

警報仕様(定格荷重指示装置付)

27002941.840

TM-ZX290 41047701345A FRAME
PO1015028-02 PLATE ASSY,NAME (FRAME SERIAL NO.)

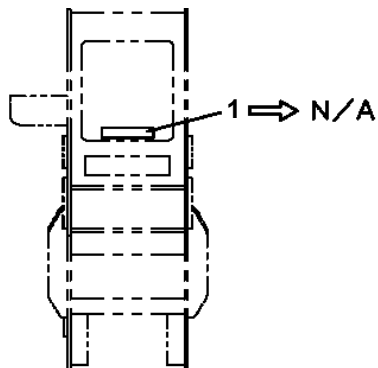

ブーム後端
BOOM END

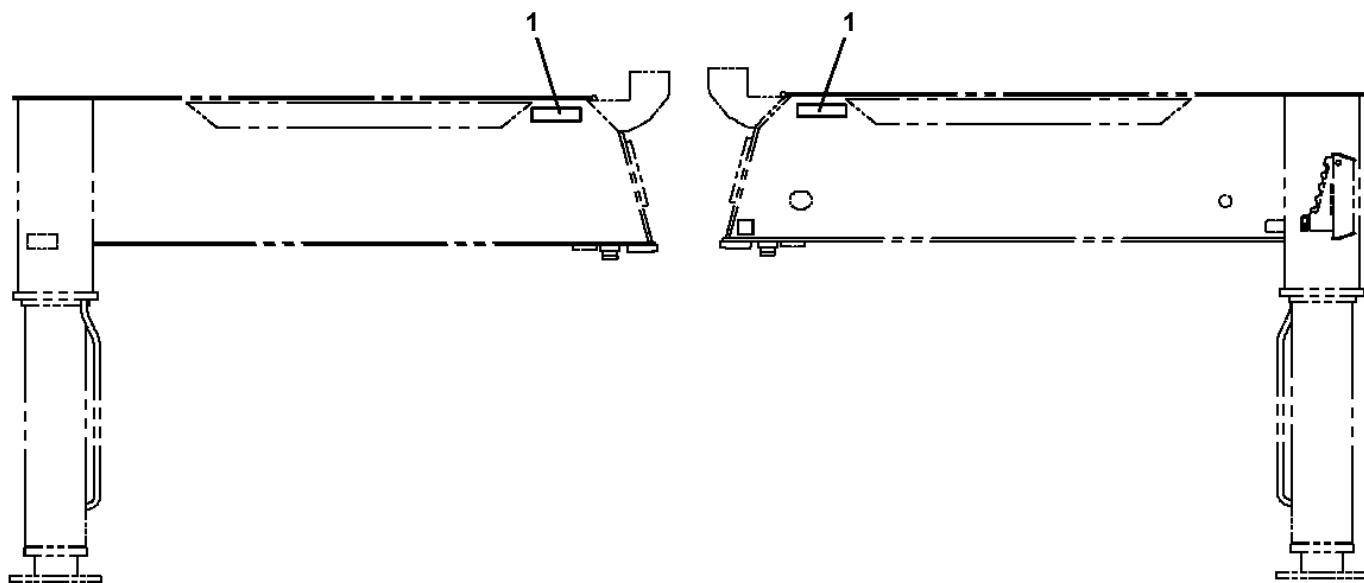

TM-ZX290 41047701345A FRAME
PO5080311-01 OPE.ASSY,CONT.VALVE (JACK,SWING)

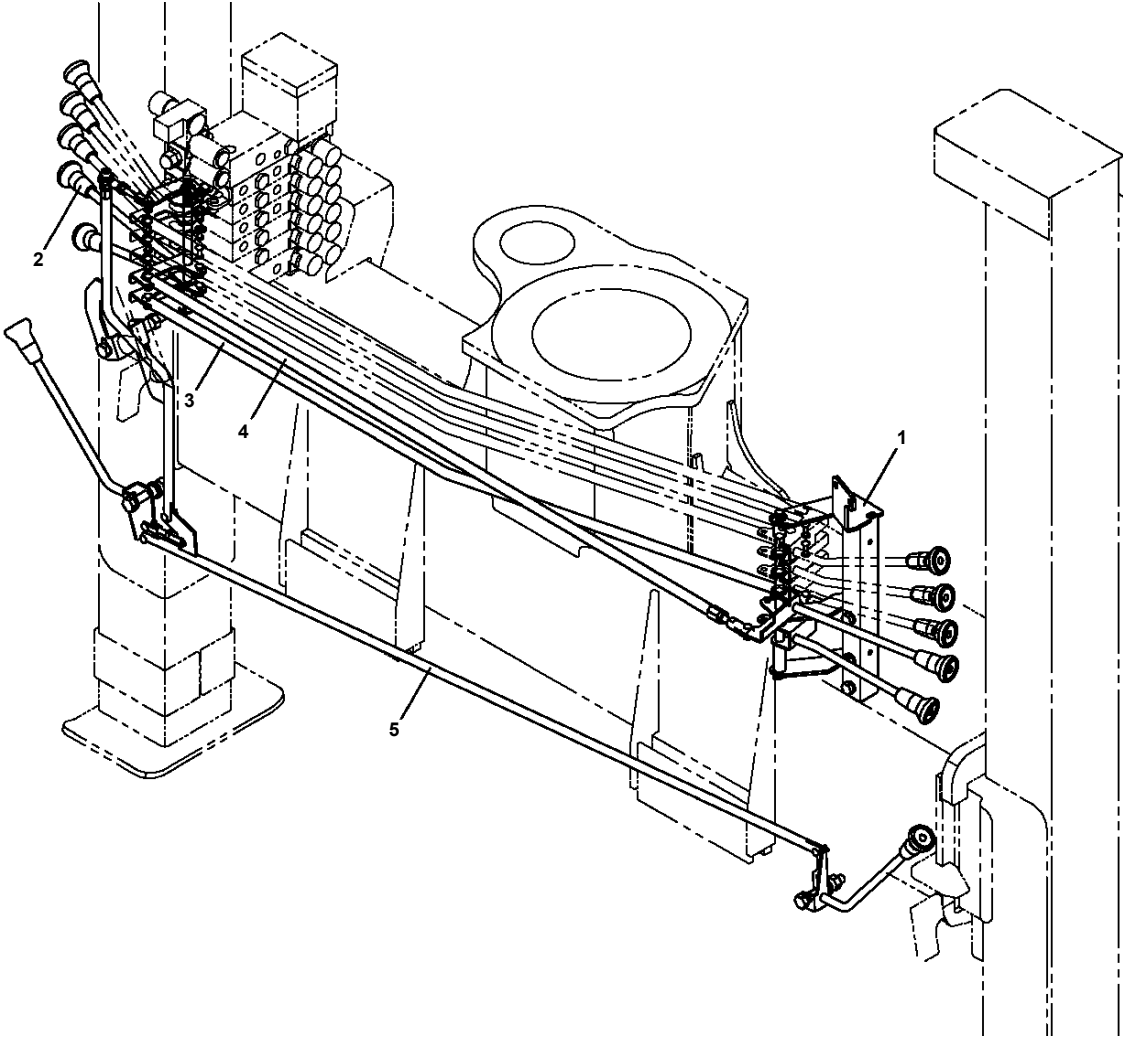

TM-ZX290 41047701345A FRAME
PO5290101-00 OUTRIGGER ASSY,REAR (ROTARY/POWER PACKAGE)

アウトリガ ASSY,リヤ (カイトンシキ/ハ ワーパ ツケーシ)
 OUTRIGGER ASSY,REAR (ROTARY/POWER PACKAGE)

符号	日本語名称	英語名称	備考
2	パイピング,リヤ ジャッキ	PIPING,REAR JACK	
3	ハイゼンASSY	ELEC.ASSY	ハ ワーパ ツケーシ 式 R/J部
4	ネームプレートASSY	NAME PLATE ASSY	
21	アウトリガ,リヤ	OUTRIGGER,REAR	回転式
22	ロックASSY {リヤアウトリガ}	LOCK ASSY	

適用製造番号によっては取り付けがないものもあります。

MACHINES OF SOME SERIAL NO. ARE NOT EQUIPPED WITH THESE PARTS.

TM-ZX290 41047701345A FRAME
PP5150047-00 PARTS ASSY,RADIO CONTROLLER (U)

パーツASSY,ラジコン(キノウシヤラジコン/Uヨウ)
PARTS ASSY,RADIO CONTROLLER (U)

符号	日本語名称	英語名称	備考
1	パーツASSY,ラジコン	PARTS ASSY,RADIO CONTROLLER	既納車ラジコン
2	ネームプレートASSY	NAME PLATE ASSY	送信機給板 (U社配列用)

適用製造番号によっては取り付けがないものもあります。

MACHINES OF SOME SERIAL NO. ARE NOT EQUIPPED WITH THESE PARTS.

TM-ZX290 41047701345A FRAME
PP5300023-00 POST ASSY

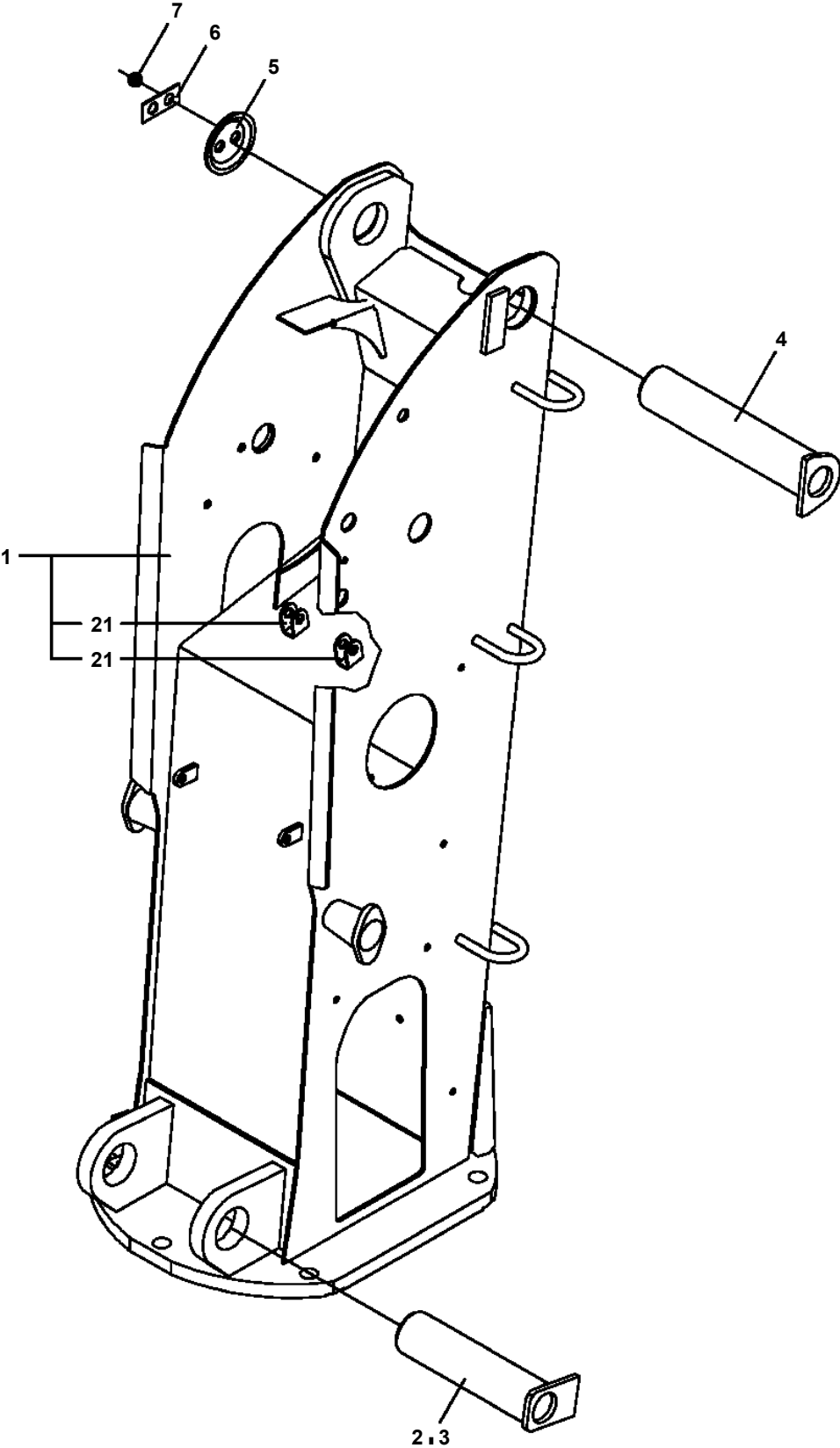

TM-ZX290 41047701345A FRAME

Pos No.	Parts No	Parts Name	Qty	Unit	Technical Data	Serial No (Start)	Serial No (End)	Remarks
1	91002801400	O-RING	2		1B P14			
2	37000912810	JOINT	1					
3	31641050100	JOINT	1					
4	36671630000	JOINT ASSY,SELF SEAL	1					
5	37000932150	JOINT	1		S,G3/8-G3/8			
6	37000924860	JOINT	1					
7	37012409650	HOSE	1		L=2250			
8	37002512880	HOSE	1		L=2500			
9	90191208030	BOLT	3		M8X30			
10	90201200800	NUT	3		M8			
11	90302040801	WASHER,SPRING	3		8			
12	80400160205	JOINT (WITH O-RING)	1					
13	80400160182	JOINT (WITH O-RING)	2					
14	91803930440	CLIP	2		32-45			
15	91002801800	O-RING	7		1B P18			
17	80400160131	JOINT	1					
18	91810150020	FASTENER	4		L=488			
21	31734222100	PLATE	1					
22	90101210020	BOLT	2		M10X20			
23	90302041001	WASHER,SPRING	2		10			
26	82100001413	TUBE,SPIRAL	1	M	SE-15BK			
27	42882090100	JOINT	1		L,G1/2-G1/2			
28	80481104046	JOINT	1					
29	37012409600	HOSE	1		L=2100			
30	37002457350	HOSE	1		L=2360			
31	90186208025	BOLT,FLANGE	6		M8X25			
32	90280200800	NUT,FLANGE	6		M8			
33	91860100022	CLAMP	4		KCR-W22			
34	91860100040	CLAMP	4		KCR-W40			
35	82100002535	TUBE,SPIRAL	1	M	SE-29BK			
37	91810160010	HOLDER	1					
38	91810130270	FASTENER	4					
51	36671635010	JOINT,SELF SEALING	1					
52	36671635020	JOINT,SELF SEALING	1					
202	36638550000	VALVE,MANUAL CONTROL	1					

**TM-ZX290 41047701345A FRAME
PP6160004-02 PIPING ASSY, GREASE**

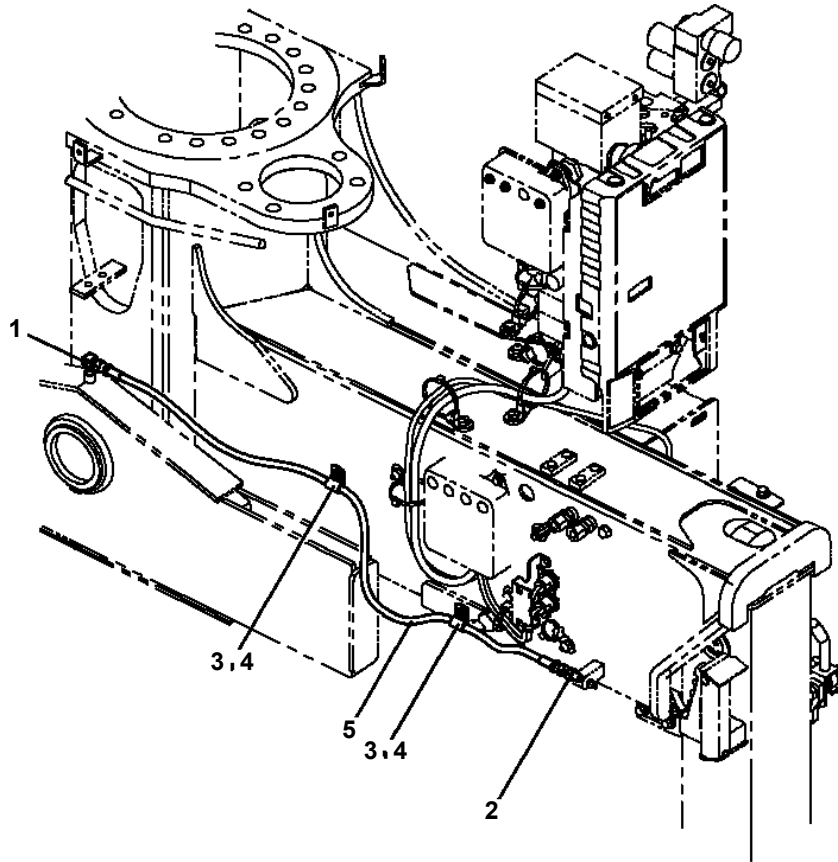

TM-30Z-7、TM-36Z-6 (STD/SL) の場合

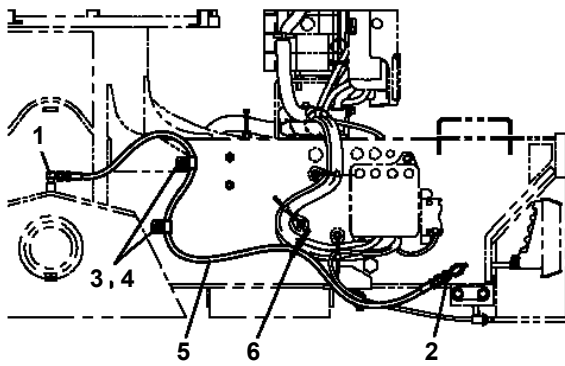

TM-29Z-7 (STD/SL) の場合

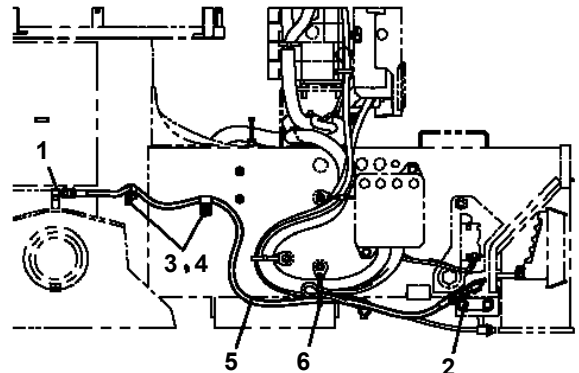

TM-26Z-6 (STD/SL) の場合

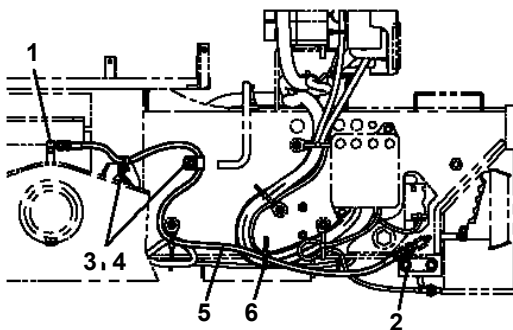

TM-25Z-4の場合

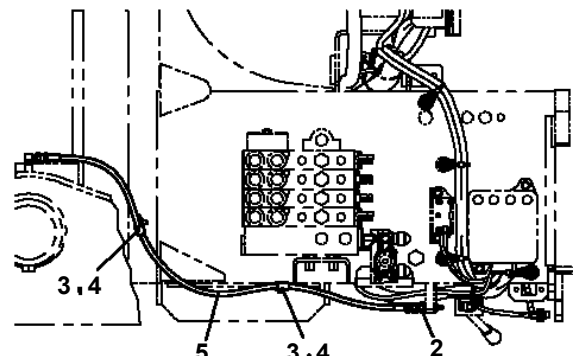

TM-50Z-6 (STD/SL) の場合

TM-ZX290 41047701345A FRAME
PS5500016-00 SWING ASSY

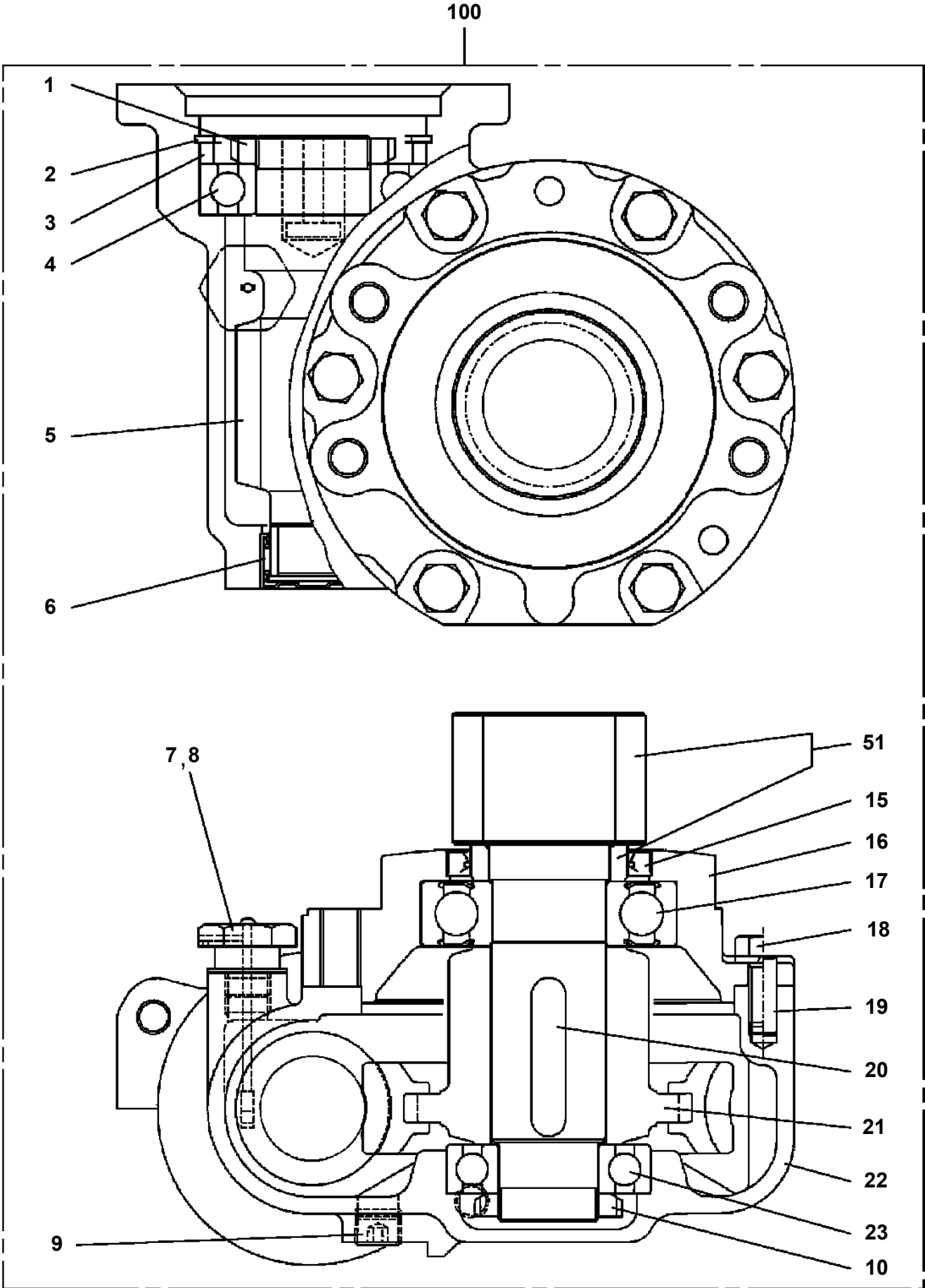

**TM-ZX290 41047701345A FRAME
PS5540019-00 SWITCH (S/W 2PC'S)**

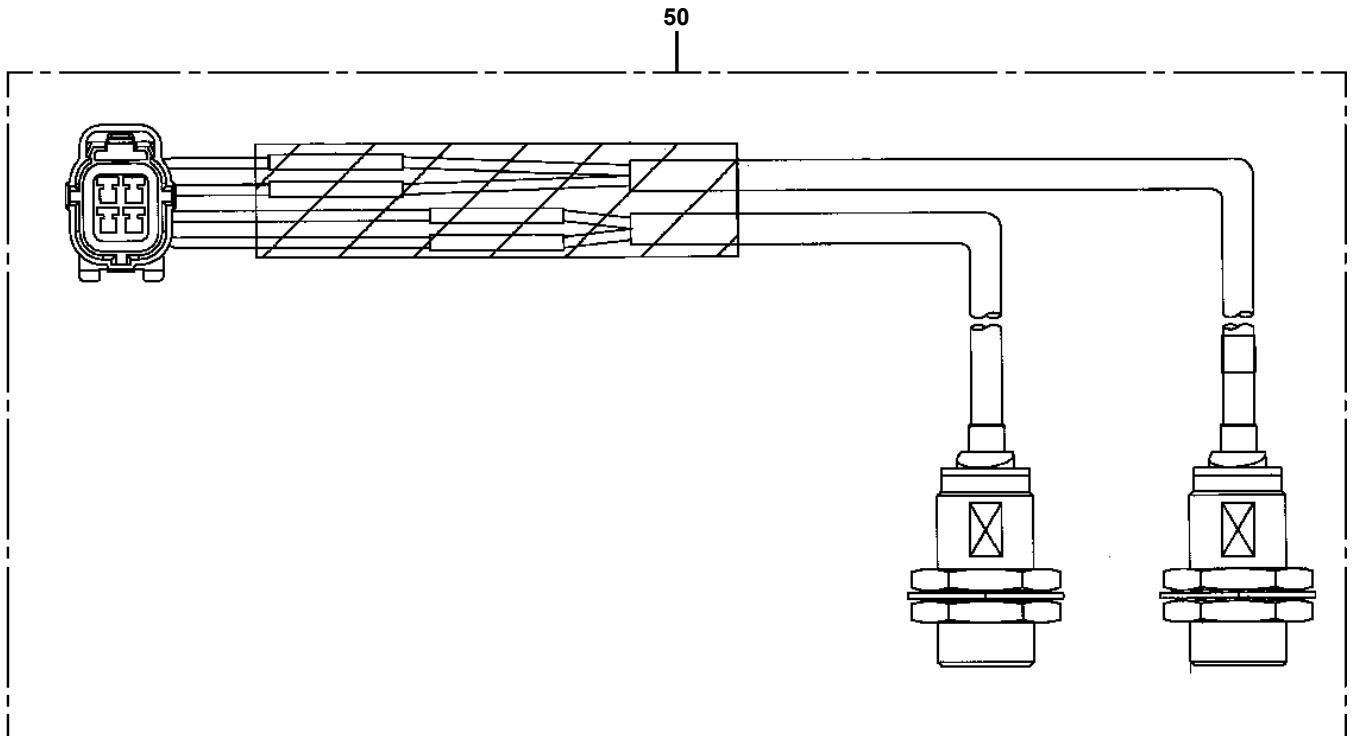

TM-ZX290 41047701345A FRAME
PV1050013-02 CYLINDER,ACCELERATOR

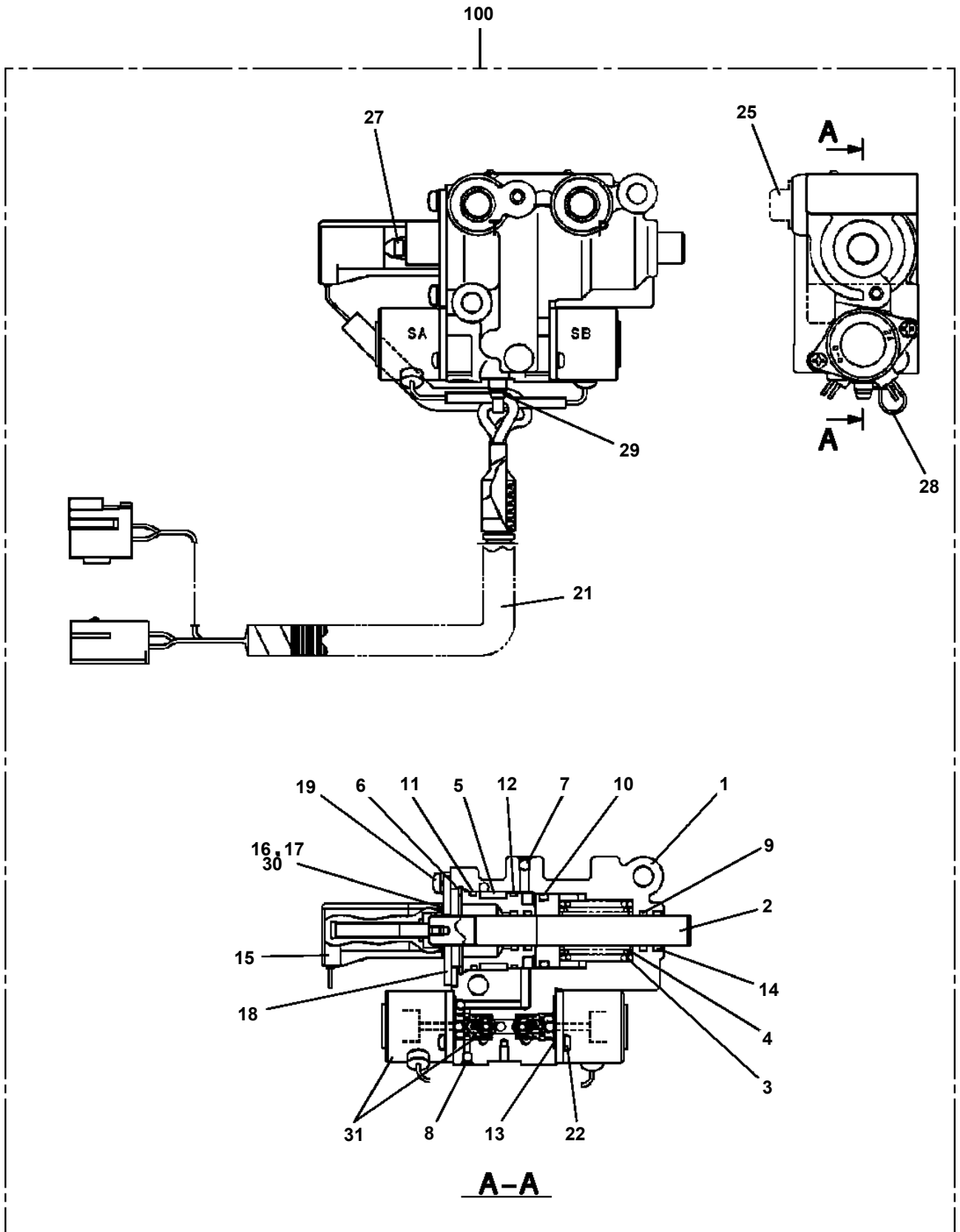

TM-ZX290 41047701345A FRAME
PV5060054-00 VALVE ASSY,CONTROL

100

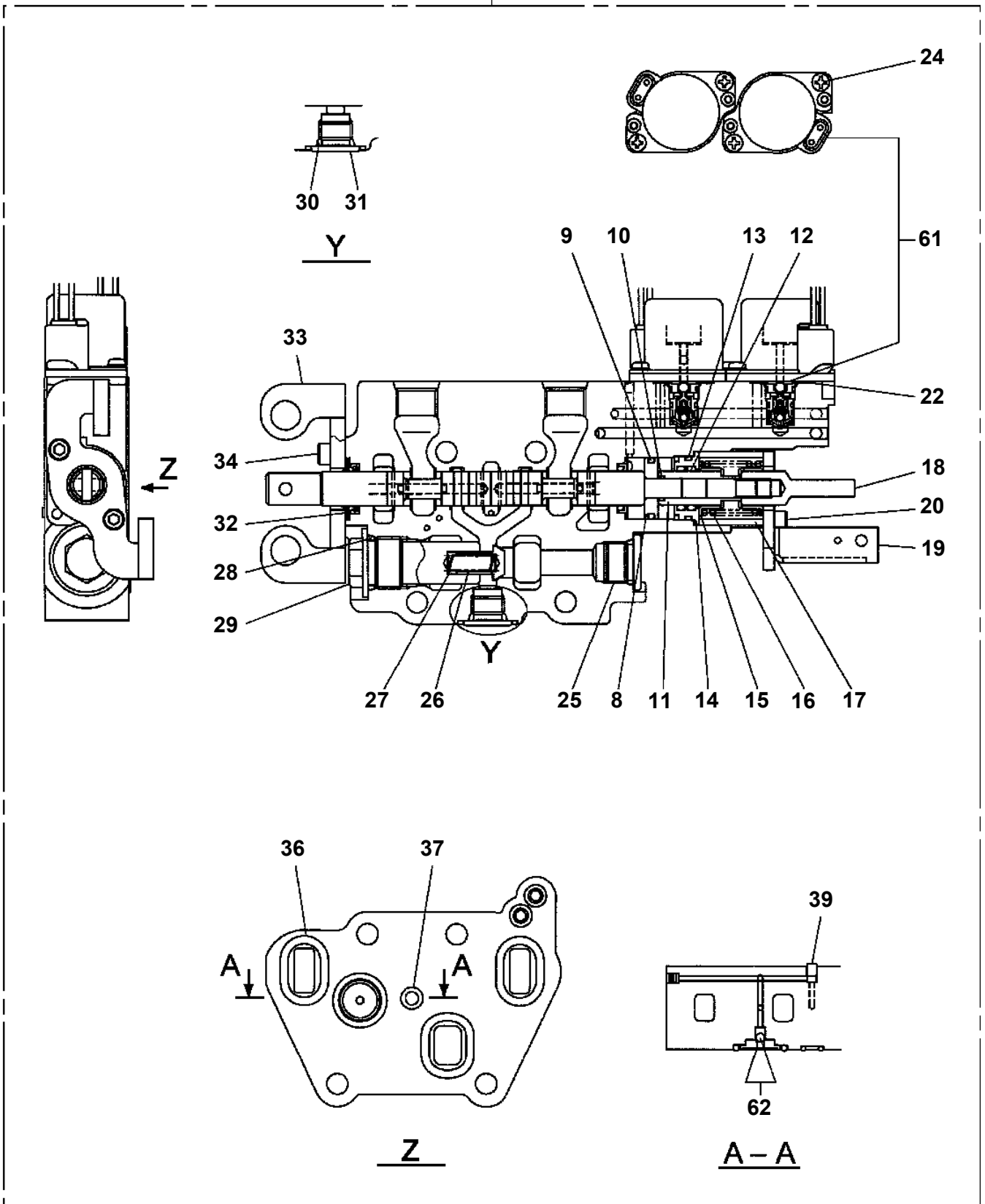

TM-ZX290 41047701345A FRAME

Pos No.	Parts No	Parts Name	Qty	Unit	Technical Data	Serial No (Start)	Serial No (End)	Remarks	Pa
8	91001100600	O-RING	1		1A P6				
9	36743055010	SCRAPER	1						
10	91001101800	O-RING	1		1A P18				
11	36637805090	RING,RETAINING	1						
13	36743055020	SPRING	1						
14	91001001600	O-RING	3		1A S16				
15	36743055030	COVER	3						
16	80172304010	SCREW,MACHINE	10		M4X10				
19	36740745160	CHOKE	1						
20	36646875150	ORIFICE	1		M3				
21	91002800700	O-RING	2		1B P7				
26	36647175100	SEAT,SPRING	1						
27	12635101140	SPRING	1						
28	36743055060	SPRING	1						
29	36743185150	SCREW (ADJUST)	1						
30	12635101130	SCREW (ADJUSTING)	1						
31	11629431040	PACKING	4						
32	36646575090	NUT	2						
33	36630195030	NUT,CAP	2						
34	36647055160	SEAT,SPRING	2						
35	36635735130	SPRING (A)	2						
36	36635735140	SPRING (B)	2						
37	36645405030	O-RING	2						
38	36646865170	ROD,PUSH	2		8				
39	36645495240	SOLENOID ASSY	1						
40	36743055070	SOLENOID ASSY	1						
41	91001102200	O-RING	1		1A P22				
43	36740745170	SPRING	1						
44	36740745180	SPRING	1						
45	91002802100	O-RING	1		1B P21				
46	16623320390	TUBE (SEAL)	2						
47	36743055090	TUBE	1						
100	36743180101	VALVE ASSY,RELIEF	1						

TM-ZX290 41047701345A FRAME

Pos No.	Parts No	Parts Name	Qty	Unit	Technical Data	Serial No (Start)	Serial No (End)	R
174	36646265090	SPRING (B)	1					
175	36646265080	SPRING (A)	1					
176	36645615210	PLUG	1		24			
177	80316030060	PLUG	1		PT3/8			
180	90303070401	WASHER,PLAIN	1		4			
300	36743380000	VALVE ASSY,REMOTE CONTROL	1					

**TM-ZX290 41047701345A FRAME
PW5060111-00 WINCH ASSY (SELF,2.5TONX1:FULL-RADIO CONTROL)**

ウインチASSY (セルフ,2.5トンX1:フルラジ コン)
WINCH ASSY (SELF,2.5TONX1:FULL-RADIO CONTROL)

符号	日本語名称	英語名称	備考
1	マウントASSY,ウインチ	MOUNT ASSY,WINCH	セルフウインチ装置
2	バルブ ASSY,リモコン	VALVE ASSY,REMOTE CONTROL	2速電磁バルブ (株)三輪精機製
3	パイカンASSY	PIPING ASSY	キャリーオーバーバルブ部
4	パイカンASSY,ウインチ	PIPING ASSY,WINCH	セルフウインチ部
5	ネームプレートASSY	NAME PLATE ASSY	セルフウインチ銘板(警告、ノブ)
10	オペレーターASSY,ソウサバルブ	OPERATOR ASSY,CONT.VALVE	キャリーオーバーバルブ部
12	ハイセンASSY	ELEC.ASSY	セルフウインチ部
14	ハイセンASSY	ELEC.ASSY	キャリーオーバーバルブ部

適用製造番号によっては取り付けがないものもあります。

MACHINES OF SOME SERIAL NO. ARE NOT EQUIPPED WITH THESE PARTS.

**TM-ZX290 41047701345A FRAME
PY2000290-02 OPTION UNIT,2 (COMMON)**

オプションユニット,2 (キョウツウ)
OPTION UNIT,2 (COMMON)

符号	日本語名称	英語名称	備考
1	フックASSY	HOOK ASSY	単乗フック
2	ガイド ASSY	GUIDE ASSY	塵埃防止 (単乗フック金)
3	フックASSY	HOOK ASSY	ロッキンク フック
4	ブロック	BLOCK	2個セット 敷板 (□355×t80)
5	ブロック	BLOCK	4個セット 敷板 (□355×t80)
6	ストッパー,タイヤ	STOPPER,TIRE	出荷部品
7	ジョイントASSY,セルフシール	JOINT ASSY,SELF SEAL	サービースポーツ用カプラー
8	マウントASSY {パワーサブライ}	MOUNT ASSY	サービースポーツ
9	パワーサブライ	POWER SUPPLY	AC100V電圧取出し (1500W)
10	パーツASSY,ラジコン	PARTS ASSY,RADIO CONTROLLER	既納車ラジコン
11	パーツASSY,ラジコン	PARTS ASSY,RADIO CONTROLLER	既納車ラジコン (U社配列用)
12	カイズ ASSY	MODIFICATION ASSY	敷板入れ (ホイールベース取付用) (□355×t80敷板用)
13	サポート	SUPPORT	敷板入れ、太陽建機レンタル向 日野小型車の東洋ポデー製ポデー及び日野中型車用
14	サポート	SUPPORT	敷板入れ、太陽建機レンタル向 日野小型車の日野内作ホデー用
15	カイズ ASSY	MODIFICATION ASSY	敷板入れ (リヤオーバークラック取付用) (□355×t80敷板用)
16	バッテリーチャージャー	BATTERY CHARGER	単三電池充電器 (ニッケル水素電池適合)
17	ディテクタ,ディソータリ Wind	DETECTOR,DISORDERLY WIND	乱進防止ローラ
18	ケーブル ASSY	CABLE ASSY	ラジコンアンテナユニット取付用 延長ハーネス (2m) (ラジコン装着機のみ)
19	パーツASSY,リモコン	PARTS ASSY,REMOTE CONTROL	ZX用リモコン
20	ボックス,ストロイング	BOX,STOWING	リモコン用ボックス
21	マウントASSY {アケル}	MOUNT ASSY	メカ式カハナ車用エンジンコントロール
22	オペレーター ASSY,ソウサババルブ	OPER. ASSY,CONT. VALVE	U社配列交換キット 小型系
23	ランプ ASSY	LAMP ASSY	ハロゲン55Wフューム作業灯
24	ランプ ASSY	LAMP ASSY	ヘッドランプ60Wホースト作業灯
25	ランプ ASSY	LAMP ASSY	LED20Wフューム作業灯
26	ランプ ASSY	LAMP ASSY	高さ制限ランプ
27	ランプ ASSY	LAMP ASSY	LED20Wホースト作業灯

適用製造番号によっては取り付けがないものもあります。

MACHINES OF SOME SERIAL NO. ARE NOT EQUIPPED WITH THESE PARTS.

TM-ZX290 41047701345A FRAME

Pos No.	Parts No	Parts Name	Qty	Unit	Technical Data	Serial No (Start)	Serial No
1	31351381103	HARNESS	1				
2	36120740000	TRANSMITTER ASSY,SIGNAL (ASSY ONLY)	1				
3	91810130250	FASTENER	16				
4	82108501340	SWITCH	1				
5	90186206010	BOLT,FLANGE	9		M6X10		
7	91850700101	CLAMP	9		L=208		
21	31659171100	COVER	2				
22	37002227560	PLATE,NAME (BLACK)	8		D=16		

TM-ZX290 41047701345A FRAME

Pos No.	Parts No	Parts Name	Qty	Unit	Technical Data	Serial No (Start)	Serial No (End)	Remarks	Pages
100	31506041000	BOX,OPERATION	1						

TM-ZX290 41047701345A FRAME

Pos No.	Parts No	Parts Name	Qty	Unit	Technical Data	Serial No (Start)	Serial
1	37000163600	PIN	1				
2	80601110300	RING,RITAINING	2		S30		
3	31616034000	CASE,OUTER	1		L=1537		
4	31611592000	CASE,INNER	1				
5	(*****)	OUTRIGGER ASSY (MIN.1149)	1				
6	37000112060	PIN	1				
7	80602110300	RING,RITAINING	2		R30		
8	37000112070	PIN	1				
9	31611594000	FLOAT ASSY	1				
10	31201770100	PLATE,SLIDE	4		T=3.0		
11	31200030530	PLATE	1				
12	90191210020	BOLT	2		M10X20		
13	90302041001	WASHER,SPRING	4		10		
14	90186208014	BOLT,FLANGE	2		M8X14		
15	31614060110	COVER	1				
16	31611300600	PLATE,NAME (YELLOW)	2				
17	31615754100	PLATE,NAME (BLUE)	2				
18	(*****)	OPE.ASSY,OUTRIGGER	1				
19	50822014000	PLATE	1				
20	37001400200	SPRING	1				
21	37002240310	PLATE,CAUTION	1				
22	37000150360	PIN	1				
23	80601110150	RING,RITAINING	2		15		
24	37000310360	SPACER	1		L=15		
25	31620582020	BEARING,BALL (KOYO)	1				
26	90171110020	BOLT	2		M10X20		
27	31615754200	PLATE,NAME (RED)	2				
47	31621963200	SUPPORT	1				
62	31610175010	TRUNNION	1				
75	31615912500	SUPPORT	1				
80	31616049510	SUPPORT	1				
100	31616030201	OUTRIGGER ASSY (LEFT,CYLINDER:MIN.1149)	1				

TM-ZX290 41047701345A FRAME

Pos No.	Parts No	Parts Name	Qty	Unit	Technical Data	Serial No (Start)	Serial No (End)	Remarks	Pa
3	90186210014	BOLT,FLANGE	2		M10X14				
4	37000924350	FITTING	4						
5	91002801100	O-RING	4		1B P11				
10	80491002020	JOINT (WITH O-RING)	4						
11	91810130240	FASTENER	6						
12	82100002039	CLAMP	4						
13	90240200800	NUT,CAP	8		M8				
14	90302040801	WASHER,SPRING	8		8				
15	37000600920	CLAMP	2		L=90				
16	31671433000	SUPPORT	2						
17	31671434000	SUPPORT	2						
18	90180208012	BOLT,BUTTON	8		M8X12				
41	37002406530	HOSE (TWIN)	2		L=3050				
42	80491002020	JOINT (WITH O-RING)	4						
43	31644591450	JOINT	2						
44	31671601101	HARNESS	2						
45	91810130240	FASTENER	14						
46	31648501300	CLAMP	2						
61	91002801100	O-RING	8		1B P11				

CLICK HERE TO **DOWNLOAD** THE COMPLETE MANUAL

- Thank you very much for reading the preview of the manual.
- You can download the complete manual from: www.heydownloads.com by clicking the link below



- Please note: If there is no response to CLICKING the link, please download this PDF first and then click on it.

CLICK HERE TO **DOWNLOAD** THE COMPLETE MANUAL