

TM-ZF500 31093010120A FRAME/SL,REMOTE-RADIO CONT.

PB2000004-01 POWER TAKE OFF & PUMP

PK2000778-00 FRAME UNIT

PO1000122-01 INDICATION PLATES

PV1000075-02 REMOTE CONTROL SYSTEM

PY1000988-00 OPTIONS (SL)

ASSEMBLY

CLICK HERE TO **DOWNLOAD** THE COMPLETE MANUAL

- Thank you very much for reading the preview of the manual.
- You can download the complete manual from: www.heydownloads.com by clicking the link below



- Please note: If there is no response to CLICKING the link, please download this PDF first and then click on it.

CLICK HERE TO **DOWNLOAD** THE COMPLETE MANUAL

TM-ZF500 31093010120A FRAME/SL,REMOTE-RADIO CONT.

Pos No.	Parts No	Parts Name	Qty	Unit	Technical Data	Serial No
1	(*****)	REMOTE CONTROL (KIT)	1			
2	(*****)	RADIO CONTROL (PARTS)	1			
3	(*****)	PARTS ASSY,RADIO CONTROLLER (KIT:LED/SANWA)	1			
	(*****)	PARTS ASSY,RADIO CONTROLLER (KIT:LED/NACHI)	1			
4	(*****)	RADIO CONTROLLER ASSY (F-TYPE:LED/WITH HOOK-IN)	1			
	(*****)	RADIO CONTROLLER ASSY (F-TYPE:LED/WITHOUT HOOK-IN)	1			
5	(*****)	PARTS,BML (3,4 SECT.MANUAL)	1			
	(*****)	PARTS,BML (3,4 SECT.HOOK-IN)	1			
	(*****)	PARTS,BML (5,6 SECT.HOOK-IN)	1			
	(*****)	PARTS,BML (5,6 SECT.MANUAL)	1			
	(*****)	PARTS,BML (3,4 SECT.RADICON HOOK-IN)	1			
	(*****)	PARTS,BML (5,6 SECT.RADICON HOOK-IN)	1			
6	(*****)	PARTS,AWL (5.6 SECT./RADICON OR MH)	1			
	(*****)	PARTS,AWL (3.4 SECT./RADICON OR MH)	1			
	(*****)	PARTS,AWL	1			
7	36800280000	CABLE,REMOTE CONTROL (T,OPTION 20M)	1			
8	36800150000	ANTENNA (15M.TRAVELLING TYPE A,B)	1			
	36802760000	ANTENNA (15M.TRAVELLING TYPE C,D,E)	1			
9	(*****)	DETECTOR,DISORDERLY WINDING	1			
10	(*****)	PLATE (355X355,H=80)	1			
11	(*****)	HOOK	1			
	(*****)	HOOK (3TON SL WINCH, 2-PART LINE/MOUNT)	1			
12	(*****)	WINCH (DRUM FREE)	1			
13	(*****)	WINCH (10TON SELF WINCH)	1			
	(*****)	WINCH (10TON SELF WINCH,REMOCON)	1			
	(*****)	WINCH (10TON SL WINCH,RADICON)	1			
	(*****)	WINCH (3TON SELF WINCH,REMOCON)	1			
	(*****)	WINCH (3TON SELF WINCH)	1			
	(*****)	WINCH (3TON SL WINCH,RADICON)	1			
14	(*****)	ROPE,GUIDE	1			
15	(*****)	OUTRIGGER,REAR (ROTARY/LOW TRUK BED)	1			
	(*****)	OUTRIGGER,REAR (ROTARY/HIGH TRUK BED)	1			
17	(*****)	LAMP (MOUNT,POST/24V-60W)	1			
18	(*****)	LAMP (MOUNT,BOOM/24V-45W)	1			
19	(*****)	ALARM SYSTEM	1			
	(*****)	ALARM SYSTEM	1			
	(*****)	ALARM SYSTEM	1			
	(*****)	ALARM SYSTEM	1			
	(*****)	ALARM SYSTEM	1			
	(*****)	ALARM SYSTEM	1			
20	(*****)	ELEC.ASSY	1			
	(*****)	ELEC.ASSY	1			
21	(*****)	ELEC.ASSY (AWL LAMP/STOP TO CONFIGURATION)	1			
22	(*****)	COOLER,OIL	1			
23	(*****)	JOINT,ROTARY (RING ASSY,SLIP)	1			
24	(*****)	PLATE ASSY,NAME (FOR FIXING AWL)	1			

EH4190
EH4190

TM-ZF500 31093010120A FRAME/SL,REMOTE-RADIO CONT.

Pos No.	Parts No	Parts Name	Qty	Unit	Technical Data	Serial No (Start)	Serial No (End)	Remarks	Page
1	36400015010	CASE	1						
2	36400015020	GEAR	1						
3	36400015030	SHAFT	1						
4	36400015040	ADAPTER	1						
5	36400015050	SHAFT (FORK)	1						
6	36400015060	FORK	1						
7	52430604200	BALL,STEEL	1		10				
8	52430604190	SPRING	1						
9	52430304150	BOLT (ADJUSTING)	1						
10	52430604180	PACKING	1						
11	52430604210	NUT	1		M12				
12	80500006306	BEARING,BALL	1						
13	80500006007	BEARING,BALL	1						
14	91206035002	SEAL,OIL	1						
15	91216020001	SEAL,OIL	1						
16	36400015070	O-RING	1						
17	36400015080	PLUG	1						
18	36400015090	PACKING	1						
19	52630203020	PACKING	1						
20	36400015100	BOLT	2		M12X50X1.15				
21	90264201200	NUT	2		M12				
22	90302041201	WASHER,SPRING	2		12				
23	90191210030	BOLT	2		M10X30				
24	36400015110	BOLT	6		M10X40X1.5				
25	90264201000	NUT	6		M10				
26	90302041001	WASHER,SPRING	8		10				
50	36400010000	POWER TAKE OFF	1						

TM-ZF500 31093010120A FRAME/SL,REMOTE-RADIO CONT.

Pos No.	Parts No	Parts Name	Qty	Unit	Technical Data	Serial No (Start)	Serial No (End)	Remarks	Page
1	51630401010	CASE	1						
2	51630401020	GEAR	1						
3	51630401030	SHAFT	1						
4	51630401040	SHAFT (FORK)	1						
5	51630401050	FORK	1						
6	90192210016	BOLT	8		M10X16				
7	90302041001	WASHER,SPRING	8		10				
8	80500006305	BEARING,BALL	1						
9	51630401140	BEARING,ROLLER	1						
10	91204020001	SEAL,OIL	1						
11	91204025003	SEAL,OIL	1						
12	51630401060	SHIM	1						
13	51630401070	COVER (FRONT)	1						
14	51630401080	COVER (REAR)	1						
15	51630401090	PACKING	2						
16	51630401100	BOLT (ADJUSTING)	1						
17	51630401110	SPRING	1						
18	90211201600	NUT	1		M16				
19	80560061000	BALL,STEEL	1		3/8				
20	52130404310	KEY	1						
21	52130102030	COUPLING	1						
22	36400135150	NUT	1		M4X1.5				
23	52230102330	STOPPER	1						
24	36400135160	WASHER,PLAIN	1						
25	51630401130	PACKING (CASE)	1						
26	90193712110	BOLT (N4B)	4		M12X110				
27	90302041201	WASHER,SPRING	4		12				
30	51630401000	POWER TAKE OFF	1						

TM-ZF500 31093010120A FRAME/SL,REMOTE-RADIO CONT.

Pos No.	Parts No	Parts Name	Qty	Unit	Technical Data	Serial No (Start)	Serial No (End)	Remarks	Page
1	52430104010	CASE	1						
2	52430103020	PACKING	1						
3	52430604050	PACKING	2						
4	90302041001	WASHER,SPRING	6		10				
5	52130404310	KEY	1						
6	52130105070	WASHER,PLAIN	1						
7	52230102330	STOPPER	1						
8	52130105090	NUT,LOCK	1						
9	91206025010	SEAL,OIL	1						
11	80500006205	BEARING,BALL	2						
12	52430103040	GEAR,OUTPUT	1						
13	52430104020	SHAFT (OUTPUT)	1						
14	52130404040	COVER	1						
15	52130105100	COVER	1						
16	52430103060	FORK	1						
17	52430604200	BALL,STEEL	1		10				
18	52430604190	SPRING	1						
19	52430304150	BOLT (ADJUSTING)	1						
20	52430604180	PACKING	1						
21	52430604210	NUT	1		M12				
22	52430103030	SHAFT (SHIFTER)	1						
23	91206020007	SEAL,OIL	1						
24	90302040801	WASHER,SPRING	3		8				
25	90191208020	BOLT	8		M8X20				
26	90191210028	BOLT	4						
27	52430104040	BOLT	2						
28	90264251000	NUT	2						
29	52130102030	COUPLING	1						
50	52430104000	POWER TAKE OFF	1						

TM-ZF500 31093010120A FRAME/SL,REMOTE-RADIO CONT.

Pos No.	Parts No	Parts Name	Qty	Unit	Technical Data	Serial No (Start)	Serial No (End)	Remarks	Page
1	52130307050	CASE	1						
2	52130307020	GEAR,INPUT	1						
3	52130307030	GEAR,OUTPUT	1						
4	52130307040	SHAFT (INPUT)	1						
5	52130307010	SHAFT (OUTPUT)	1						
6	52130307060	SHAFT (SHIFTER)	1						
7	52130307070	SHAFT	1						
8	52130307080	FORK (SHIFTER)	1						
9	52130202330	COVER	1						
10	52130202320	COVER (BEARING)	1						
11	52130202030	YOKE	1						
12	52130307120	COLLAR	1						
13	52130307120	COLLAR	1						
14	80500006206	BEARING,BALL	2						
15	80500006205	BEARING,BALL	2						
16	91206030009	SEAL,OIL	1						
17	91206020007	SEAL,OIL	1						
18	52130307180	KEY	1						
19	52430304110	KEY	1						
20	52130105070	WASHER,PLAIN	1						
21	52430101090	WASHER,PLAIN	1						
22	52430604180	PACKING	1						
23	90209201200	NUT	1		M12				
24	90209201200	NUT	1		M12				
25	52430304150	BOLT (ADJUSTING)	1						
26	52130003200	SCREW,SET	1						
27	80560010000	BALL,STEEL	1		10				
28	52430604190	SPRING	1						
29	52130307290	PACKING	2						
30	90191210020	BOLT	8		M10X20				
31	90302041001	WASHER,SPRING	8		10				
32	52130307320	PLUG	1						
33	52130307330	PACKING	1						
50	52130307000	POWER TAKE OFF	1						

TM-ZF500 31093010120A FRAME/SL,REMOTE-RADIO CONT.

Pos No.	Parts No	Parts Name	Qty	Unit	Technical Data	Serial No (Start)	Serial No (End)	Remarks	Pages
1	36400435010	CASE	1						
2	36400435020	GEAR	1						
3	36400435030	SHAFT	1						
4	36400435040	SLEEVE	1						
5	36400435050	BEARING,PLAIN	1						
6	36400435060	SHIFTER SET	1						
7	36400095110	PACKING	1						
8	36400095070	COVER (BEARING)	1						
9	36400095080	PACKING (COVER)	1						
10	36400095090	SHIM	N						
11	36400435070	COLLAR	1						
12	80500006206	BEARING,BALL	1						
13	80500006007	BEARING,BALL	1						
14	80801002520	BEARING,PLAIN	2						
15	91216035002	SEAL,OIL	1						
16	90191208014	BOLT	3		M8X14				
17	90191208020	BOLT	4		M8X20				
18	90302040801	WASHER,SPRING	7		8				
19	36400435080	PLATE,NAME	1						
21	36400435090	PACKING (CASE)	1						
22	36400435100	BOLT,STUD	2						
23	36400435110	BOLT,STUD	2						
24	36400435120	BOLT,STUD	2						
25	90267401200	NUT	6						
26	90302041201	WASHER,SPRING	6		12				
27	31790680100	SUPPORT	1						
28	90191208025	BOLT	2		M8X25				
50	36400430000	POWER TAKE OFF	1						
100	31791760000	POWER TAKE OFF	1						

TM-ZF500 31093010120A FRAME/SL,REMOTE-RADIO CONT.

Pos No.	Parts No	Parts Name	Qty	Unit	Technical Data	Serial No (Start)	Serial No (End)	Remarks	Pa
1	36400845060	CASE	1						
2	36400845020	GEAR	1						
3	36400845030	SHAFT	1						
4	36400845040	GEAR	1						
5	36400395050	SHAFT	1						
6	36400095100	SHIFTER ASSY	1						
7	36400095110	PACKING	1						
8	36400095070	COVER (BEARING)	1						
9	36400095080	PACKING (COVER)	1						
10	36400095090	SHIM	1						
11	36400675030	COLLAR	1						
12	80500006206	BEARING,BALL	2						
13	36400675050	BEARING	2						
14	91206030005	SEAL,OIL	1						
15	80602110520	RING,RITAINING	2		R52				
16	36400095130	WASHER	1						
17	90101206015	BOLT	1		M6X15				
18	90191208020	BOLT	4		M8X20				
19	90191208014	BOLT	3		M8X14				
20	90302040801	WASHER,SPRING	7		8				
21	36401025060	PLUG	1						
22	36401025070	WASHER,PLAIN	1						
24	36401025090	PLATE,NAME	1						
25	36401025100	PACKING	1						
26	36400095150	BOLT,STUD	6		M10X1.25/1.5X43				
27	90267201000	NUT	6		M10				
28	90302041001	WASHER,SPRING	6		10				
29	31790770100	SUPPORT	1						
30	90191208025	BOLT	2		M8X25				
31	36401025120	NUT (REINFORCER)	1						
50	36400840000	POWER TAKE OFF	1						
100	31790770000	POWER TAKE OFF	1						

TM-ZF500 31093010120A FRAME/SL,REMOTE-RADIO CONT.

Pos No.	Parts No	Parts Name	Qty	Unit	Technical Data	Serial No (Start)	Serial No (End)	Remark
2	51630103010	CASE (P.T.O)	1					
3	51630103020	SHAFT (POWER TAKE OFF)	1					
4	51630103030	BEARING,NEEDLE	1					
6	36400955010	GEAR	1					
7	51630103050	WASHER	2					
8	51630103060	PIN,SPRING	1					
9	36400955020	SHAFT (OUTPUT)	1					
10	51630103080	BEARING,NEEDLE	2					
12	51630103090	GEAR,OUTPUT	1					
13	51630103100	WASHER	1					
15	51630103110	SLEEVE	1					
16	80500006206	BEARING,BALL	3					
17	52630106230	COVER (FRONT)	1					
18	36400955030	ADAPTER	1					
19	51630103140	GASKET	2					
20	51630103150	BOLT	4					
21	36400955040	BOLT	4		M8X25X1.25			
22	36400955050	SEAL,OIL	1					
25	51630103170	SHAFT	1					
26	51630103180	FORK	1					
27	51630103190	BOLT	1					
28	52630106200	BALL,STEEL	1					
29	52630106190	SPRING	1					
30	51630103200	PLUG	1					
31	51630103210	PLUG	1					
32	51630103220	SEAL,OIL	1					
33	51630103230	BOLT	1					
35	51630103240	NUT	1					
36	51630103250	GASKET	1					
37	51630103260	GASKET	1					
38	36400315040	BOLT	6					
40	36400955060	COUPLING	1					
41	36400955070	RING,STOP	1					
50	36400950000	POWER TAKE OFF	1					

TM-ZF500 31093010120A FRAME/SL,REMOTE-RADIO CONT.

Pos No.	Parts No	Parts Name	Qty	Unit	Technical Data	Serial No (Start)	Serial No (End)	Remarks	Pages
1	36401105010	CASE	1						
2	36401105100	GEAR	1						
3	36401105030	SHAFT	1						
4	36401105110	GEAR	1						
5	36401105050	COLLAR	1						
6	36400395050	SHAFT	1						
7	36400095070	COVER (BEARING)	1						
8	36400095080	PACKING (COVER)	1						
9	36400095090	SHIM	1						
10	36401105060	SHIFTER SET	1						
11	36400995080	PACKING	1						
12	80500006206	BEARING,BALL	2						
14	36400675050	BEARING	2						
15	80602110520	RING,RITAINING	2		R52				
16	91206030005	SEAL,OIL	1						
17	90101206015	BOLT	1		M6X15				
18	36400095130	WASHER	1						
19	90191208020	BOLT	4		M8X20				
20	90191208014	BOLT	3		M8X14				
21	90302040801	WASHER,SPRING	7		8				
23	36400915060	PACKING	2						
24	36401105120	SPACER	1						
25	36401105080	BOLT	6						
26	90267401200	NUT	6						
27	90302041201	WASHER,SPRING	6		12				
29	90191208025	BOLT	2		M8X25				
30	31790790100	SUPPORT	1						
50	36401100000	POWER TAKE OFF	1						
100	31790850000	POWER TAKE OFF	1						

TM-ZF500 31093010120A FRAME/SL,REMOTE-RADIO CONT.

Pos No.	Parts No	Parts Name	Qty	Unit	Technical Data	Serial No (Start)	Serial No (End)	Remarks	Page
1	36401785010	CASE	1						
2	36401785020	GEAR	1						
3	36401785030	SHAFT	1						
4	36401785040	GEAR	1						
5	36401785050	SHAFT	1						
6	36401105060	SHIFTER SET	1						
7	36400995080	PACKING	1						
8	36400995040	COVER	1						
9	36400995050	PACKING (COVER)	1						
10	36400995060	SHIM	N						
11	36401785060	COLLAR	1						
12	80500006306	BEARING,BALL	2						
13	36400135070	BEARING	2						
14	91206030005	SEAL,OIL	1						
15	80602110620	RING,RITAINING	2		R62				
16	90101206012	BOLT	1		M6X12				
17	36400095130	WASHER	1						
18	90191210016	BOLT	4		M10X16				
19	90302041001	WASHER,SPRING	12		10				
20	90191208020	BOLT	4		M8X20				
21	90302040801	WASHER,SPRING	4		8				
22	36401785070	PLUG	1						
25	36401375050	PACKING	1						
26	36400095150	BOLT,STUD	4		M10X1.25/1.5X43				
27	90191210030	BOLT	4		M10X30				
28	90267201000	NUT	4		M10				
30	90191208025	BOLT	2		M8X25				
31	31790790100	SUPPORT	1						
50	36401780000	POWER TAKE OFF	1						
100	31790820000	POWER TAKE OFF	1						

TM-ZF500 31093010120A FRAME/SL,REMOTE-RADIO CONT.

Pos No.	Parts No	Parts Name	Qty	Unit	Technical Data	Serial No (Start)	Serial No (End)	Remarks
1	36651645010	SEAL KIT	1					
10	36653390000	PUMP,HYDRAULIC (SGP2-36)	1					

TM-ZF500 31093010120A FRAME/SL,REMOTE-RADIO CONT.

Pos No.	Parts No	Parts Name	Qty	Unit	Technical Data	Serial No (Start)	Serial No (End)	Remarks
1	31630475100	BODY	1					
2	31630635200	CORE	1					
3	91531208000	PACKING	2					
4	91100308000	RING,SEAL	7					
5	31630735500	RING,SLIP (WITH BRUSH)	1				EW0427	
	31631631100	RING,SLIP	1			EW0428		
6	82121502030	PLATE	1					
7	82114203030	CONNECTOR (CAP)	1					
10	90180208016	BOLT,BUTTON	2		M8X16			
11	90302040801	WASHER,SPRING	6		8			
12	90102208014	BOLT	4		M8X14			
13	90303070801	WASHER,PLAIN	4		8		EW0427	
	90303070801	WASHER,PLAIN	6		8	EW0428		
14	90303100801	WASHER,PLAIN	2		8		EW0427	
20	31630479910	PACKING SET	1					
30	31630801000	JOINT,ROTARY (MURAKAMI)	1					

**TM-ZF500 31093010120A FRAME/SL,REMOTE-RADIO CONT.
PB1410779-00 PIPING,HYDRAULIC LOWER**

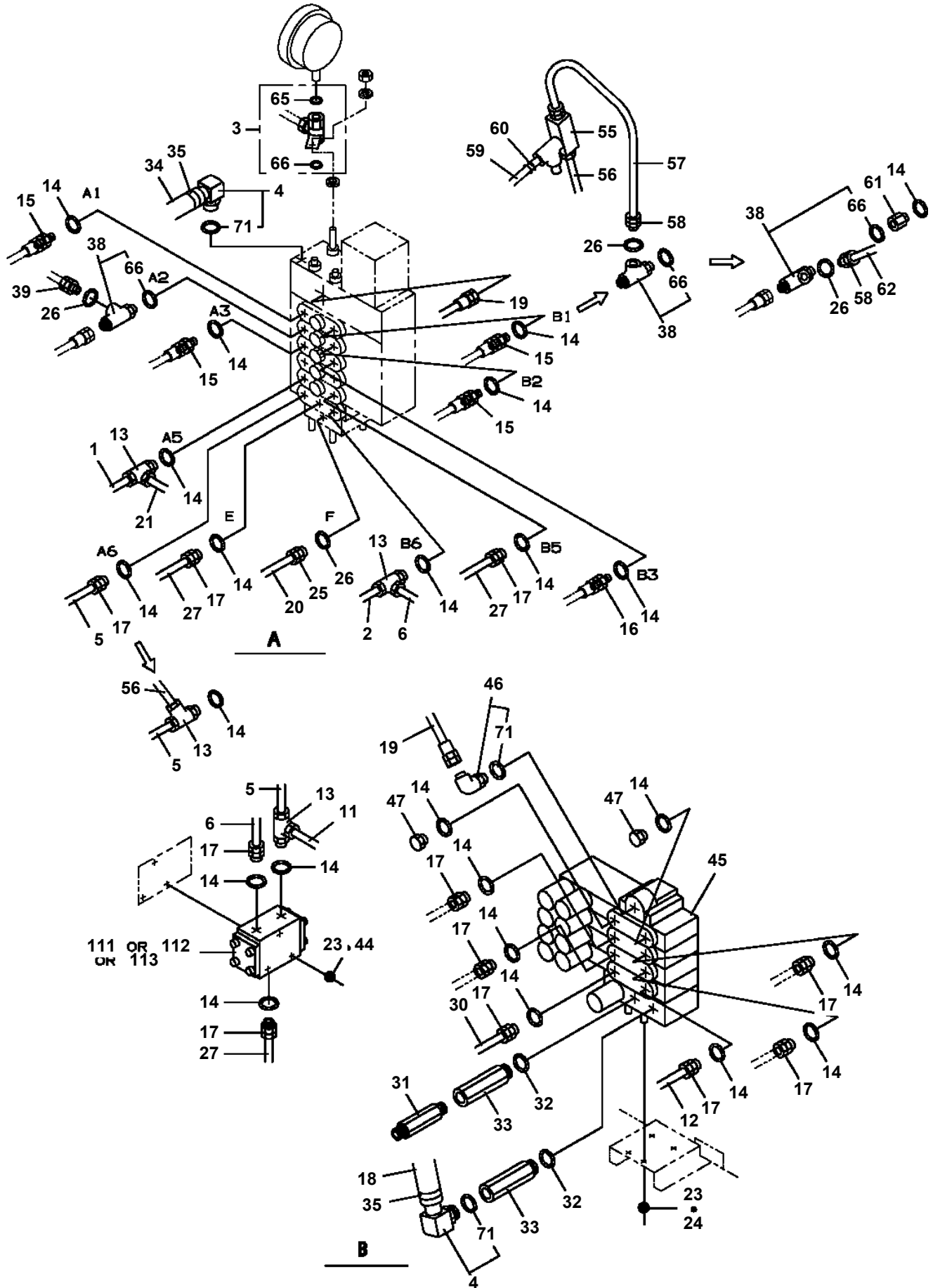

TM-ZF500 31093010120A FRAME/SL,REMOTE-RADIO CONT.

Pos No.	Parts No	Parts Name	Qty	Unit	Technical Data	Serial No (Start)	Serial N
96	90303070801	WASHER,PLAIN	2		8		
97	90302040801	WASHER,SPRING	2		8		
98	90201200800	NUT	2		M8		
99	31642851530	SUPPORT	2				
111	91002802900	O-RING	1		1B P29		
122	36611130000	VALVE,DIVIDING & COMBINING (MURAKAMI)	1				
131	91002801100	O-RING	4		1B P11		

TM-ZF500 31093010120A FRAME/SL,REMOTE-RADIO CONT.

Pos No.	Parts No	Parts Name	Qty	Unit	Technical Data	Serial No (Start)	Serial No (End)	Rem
1	(*****)	OUTRIGGER (SL.RIGHT,L=550)	1					
2	(*****)	OUTRIGGER (SL.LEFT,L=550)	1					
3	37000165470	PIN	2					
4	90101210016	BOLT	4		M10X16		EH7134	
	90101210018	BOLT	4		M10X18	EH7135		
5	90302041001	WASHER,SPRING	4		10			
6	37000920970	JOINT	4		S,G1/4-G1/4			
7	91002801100	O-RING	4		1B P11			
8	90303071001	WASHER,PLAIN	2		10	EH7135		

TM-ZF500 31093010120A FRAME/SL,REMOTE-RADIO CONT.

Pos No.	Parts No	Parts Name	Qty	Unit	Technical Data	Serial No (Start)	Serial No
1	(*****)	CYLINDER,JACK (REAR/STROKE 330MM)	2				
11	31478091550	CASE,OUTER	1				
12	31622102000	CASE,INNER	2				
13	31621343000	CASE (LEFT H=555)	1				
14	31621344000	CASE (RIGHT H=555)	1				
15	31622103000	SUPPORT	1				
16	31622104000	SUPPORT	1				
17	90171118040	BOLT	8		M18X40		
18	90302041801	WASHER,SPRING	8		18		
19	31200713400	SHIM	2		T=0.6		
20	31621340401	COVER	2				
21	90186208016	BOLT,FLANGE	4		M8X16		
22	37000162930	PIN	2				
23	80314110060	NUT	4		PT10		
24	80314120060	SLEEVE	4		PT10		
25	31620386000	BOLT	2				
26	90203252000	NUT	2				
27	37000300170	SPACER	4		L=16		
28	42310210500	PIN	2				
29	37000308620	SPACER	4				
31	37003100030	GRIP	2				
32	37001200720	SPRING	2				
33	31621340200	PIN	2				
34	31621340100	PLATE	2				
35	90172112030	BOLT,HEXAGON SOCKET	12		M12X30		
36	90302401201	WASHER,SPRING (12)	12				
37	31620437000	GUIDE	8				
38	90101210025	BOLT	8		M10X25		
39	90302041001	WASHER,SPRING	12		10		
40	81408000130	PIPE,STEEL	4	M	10X1.8T		
44	80314130080	FITTING	4		PA10PT1/4		
45	82456201000	NIPPLE,GREASE	2		A-TYPE PT1/8		
46	82400000459	CAP	2				
47	80601110200	RING,RITAINING	8		S20		
48	37001100660	ROLLER ASSY	6				
49	37000303100	SPACER	2		L=129		
61	31621340300	SUPPORT	2				
62	90171116045	BOLT	8		M16X45		EH2598
	90171116050	BOLT	8		M16X50	EH2599	
63	90201781600	NUT	8		M6		EH2598
	90202781600	NUT	16		M16	EH2599	
64	90302041601	WASHER,SPRING	8		16		EH2598
65	37000539370	PLATE	2				
71	31622141200	PIN ASSY	2				
81	31642900100	PIPE ASSY (LEFT)	1				
82	31642900200	PIPE ASSY (RIGHT)	1				
83	37002408200	HOSE	4		L=1060		
84	44340295000	JOINT,SWIVEL	4		PT1/4XPF1/4		
85	90101210020	BOLT	4		M10X20		
91	44340297520	REPAIR KIT (O-RINGX2 BACKUPX2SEALX2)	4				
122	80516006004	BEARING,BALL	6				

TM-ZF500 31093010120A FRAME/SL,REMOTE-RADIO CONT.

Pos No.	Parts No	Parts Name	Qty	Unit	Technical Data	Serial No (Start)	Serial No (End)
1	36620990000	VALVE,PILOT CHECK	1				
2	90172110035	BOLT,HEXAGON SOCKET	2		M10X35		
3	90172110025	BOLT,HEXAGON SOCKET	4		M10X25		
4	90302041001	WASHER,SPRING	4		10		
5	36032650001	CYLINDER,JACK	1				
11	36032651000	CYLINDER	1				
12	80136363071	PIN,SPLIT	1		6.3X71		
13	37001600000	NUT,CASTLE	1		M36		
14	36032654000	ROD	1				
15	91350207500	BEARING,PLAIN (WITH PACKINGX2)	1				
16	91002803400	O-RING	1		1B P34		
17	36032652000	PISTON	1				
18	36030643000	COVER,ROD	1				
19	91002907000	O-RING	1		1B G70		
20	91694006000	PACKING	1				
21	91410206002	RING,BACKUP	1				
22	36010130030	WASHER	1				
23	91660006000	SEAL,DUST	2				
24	80622000600	RING,RITAINING	1		SP60		
30	36032659900	PACKING SET	1		60X75		

TM-ZF500 31093010120A FRAME/SL,REMOTE-RADIO CONT.

Pos No.	Parts No	Parts Name	Qty	Unit	Technical Data	Serial No (Start)	Serial No (End)	Remarks	Pages
1	82401600506	CLAMP	8		D6.5				
2	31360204100	HARNESS	1						
3	91810130250	FASTENER	8						
4	91810130240	FASTENER	8						
5	31360204300	SWITCH ASSY	2						
6	90101206008	BOLT	4		M6X8				
7	90302040601	WASHER,SPRING	4		6				
8	82100002596	RELAY	1						
9	80192486010	SCREW,MACHINE	1		M6X10				
10	31360204200	BUZZER ASSY	1						
21	31360204400	SWITCH ASSY	2						
22	31360204310	SUPPORT	2						
31	82108101100	SWITCH	2						

TM-ZF500 31093010120A FRAME/SL,REMOTE-RADIO CONT.

Pos No.	Parts No	Parts Name	Qty	Unit	Technical Data	Serial No (Start)	Serial No (End)	Remarks
1	80602110850	RING,RITAINING	1		R85			
2	36080755010	SPACER	1					
3	80561100090	NUT	1		AN09			
5	80500005209	BEARING,BALL	1					
6	36080755020	WORM	1					
7	36080755030	BEARING,NEEDLE	1		BK3020+IR25*30*18			
8	36080755040	GAUGE,OIL	1					
9	36080235080	WASHER,SEAL	1		M16			
10	80316090060	PLUG	1		KKT PT3/8			
13	36080015091	SEAL,OIL	1					
14	36080755060	CASE,GEAR	1					
15	80520045010	BEARING,ROLLER	1					
16	36080505110	BOLT (WITH WASHER)	9		M10X30			
17	36080505080	KEY	1					
18	36080755070	WHEEL,WORM	1					
19	36080755080	CASE,GEAR	1					
20	80500006209	BEARING,BALL	1					
21	80601110450	RING,RITAINING	1		S45			
22	36080015000	PIN	2					
23	14123000400	BREATHER	1		PT1/8			
26	82400000478	BREATHER	1			EH2606		EH2605
31	36080755100	GEAR,SPUR	1					
50	36080750000	REDUCER,SWING SPEED	1					

TM-ZF500 31093010120A FRAME/SL,REMOTE-RADIO CONT.

Pos No.	Parts No	Parts Name	Qty	Unit	Technical Data	Serial No (Start)	Serial No (End)	Remarks	Pa
1	80400160131	JOINT	1						
2	91002801800	O-RING	1		1B P18				
3	91810130240	FASTENER	4						
4	80400160190	JOINT (WITH O-RING)	1						
5	91803880070	CLIP	2		D=13.1-16.2				
6	80302120080	FITTING	4		POA10PF3/8				
7	91002801400	O-RING	4		1B P14				
8	37002504790	HOSE	1		L=1500				
9	81408000100	PIPE,STEEL	2	M	10X1.2T				
10	81408000100	PIPE,STEEL	2	M	10X1.2T				
11	37000602910	CLAMP	2						
12	90101208045	BOLT	1		M8X45				
13	90302040801	WASHER,SPRING	1		8				
14	90201200800	NUT	1		M8				
31	91002801100	O-RING	1		1B P11				

TM-ZF500 31093010120A FRAME/SL,REMOTE-RADIO CONT.

Pos No.	Parts No	Parts Name	Qty	Unit	Technical Data	Serial No (Start)	Serial No (End)	Rem
1	82401601002	CLAMP	4					
2	91810130240	FASTENER	10					
3	31360201600	COVER	1					
4	82100002596	RELAY	2					
5	31475371100	HARNESS	1					
6	80192486010	SCREW,MACHINE	3		M6X10			
7	31473460300	HARNESS (RED)	1		L=1600			
8	31380291200	RELAY ASSY (WITH HARNESS)	1					

TM-ZF500 31093010120A FRAME/SL,REMOTE-RADIO CONT.

Pos No.	Parts No	Parts Name	Qty	Unit	Technical Data	Serial No (Start)	Serial No (End)	Remarks
1	31500701100	HARNESS	1					
2	82100002596	RELAY	1				PA2685	
	34354781720	RELAY (WITH HARNESS)	1			PA2686		
3	31473744700	HARNESS (L=1000)	1					
4	91810130240	FASTENER	4					
5	44630111170	SPACER	1					
6	90186206045	BOLT,FLANGE	1		M6X45			
7	90303070601	WASHER,PLAIN	1		6			

**TM-ZF500 31093010120A FRAME/SL,REMOTE-RADIO CONT.
PF1010132-00 WINCH (SELF 3TX1,OPTION)**

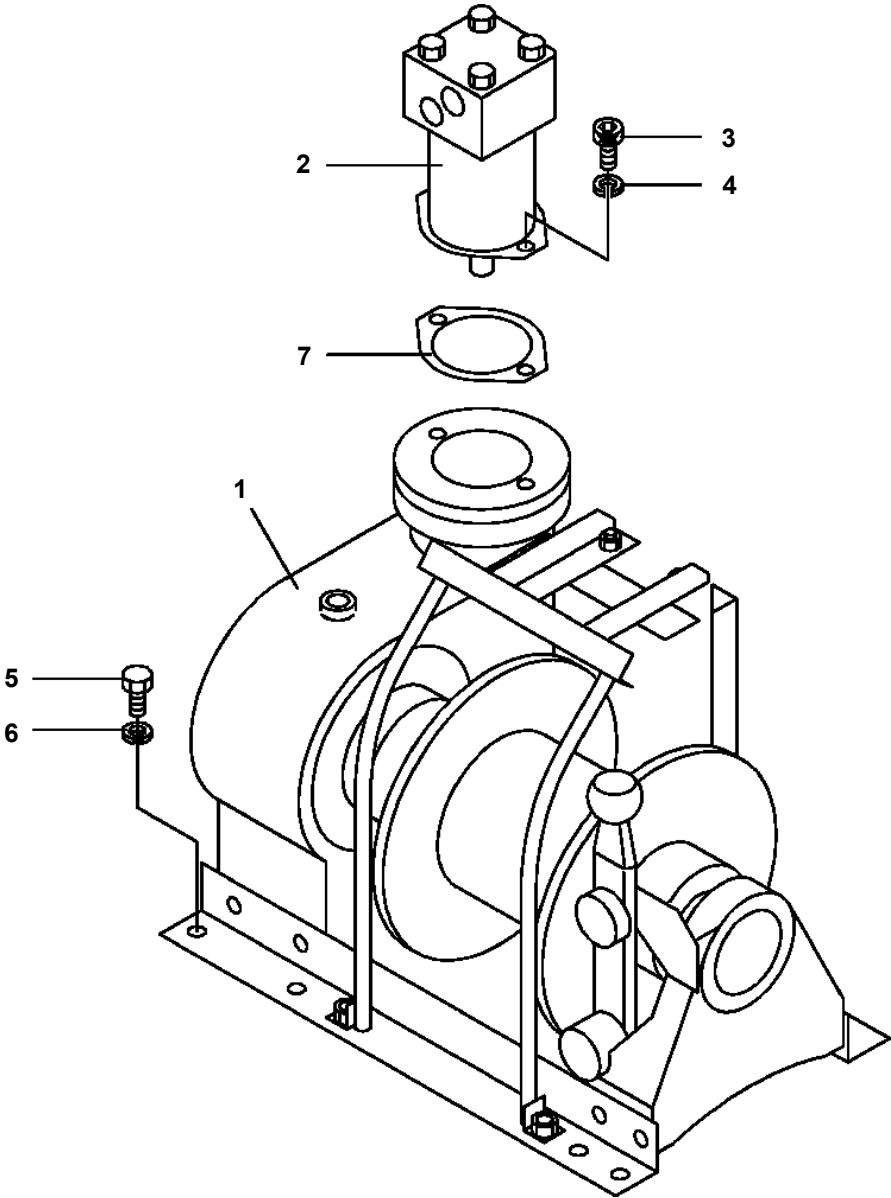

**TM-ZF500 31093010120A FRAME/SL,REMOTE-RADIO CONT.
PF1010167-02 WINCH (HARTYS)**

100

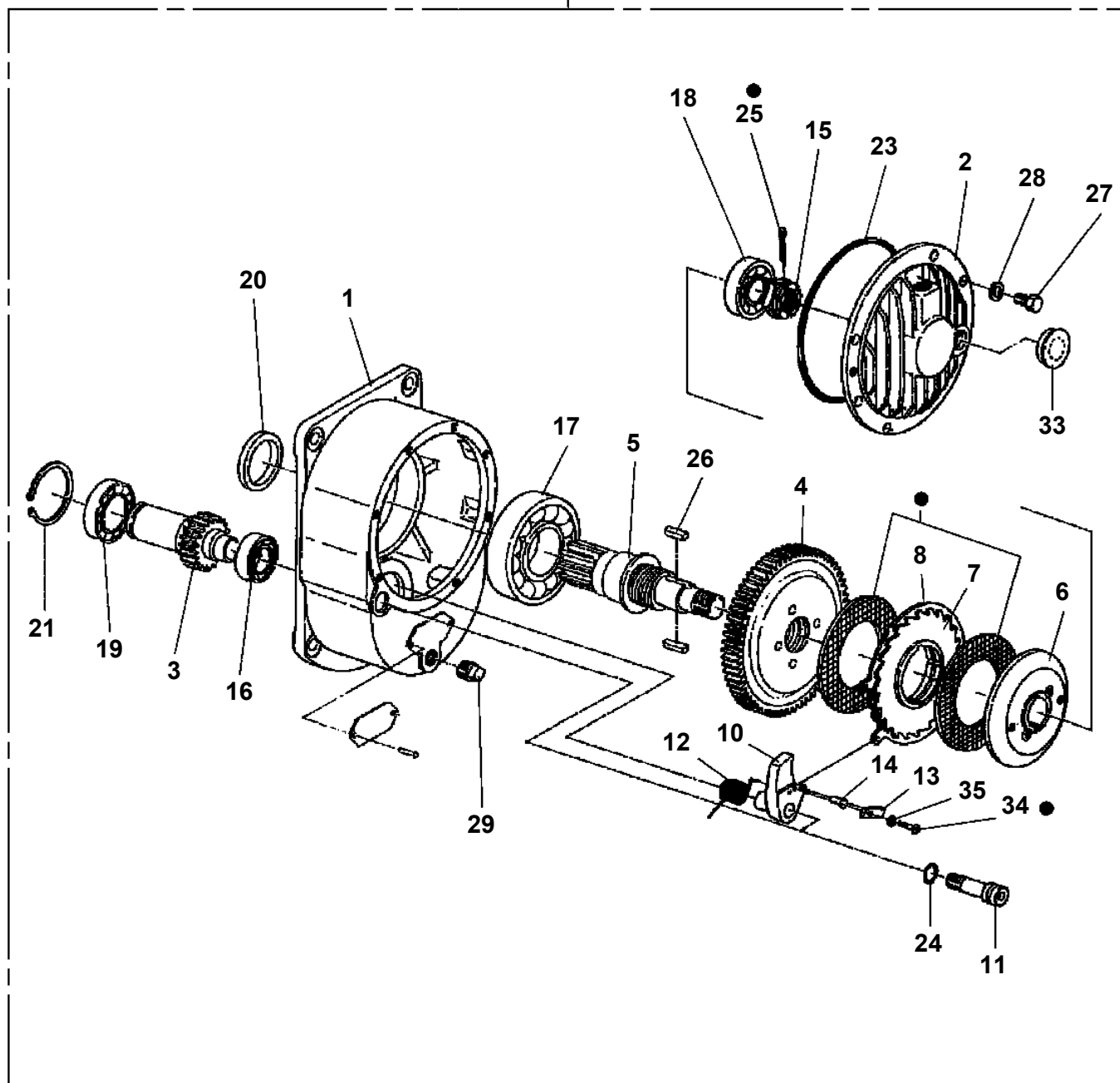

● : FACING KIT KEY NO.101 (JAPANESE)

● : FACING KIT KEY NO.102 (ENGLISH)



● Protective seal

● Replacement interval name plate

TM-ZF500 31093010120A FRAME/SL,REMOTE-RADIO CONT.

Pos No.	Parts No	Parts Name	Qty	Unit	Technical Data	Serial No (Start)	Serial No (End)	Remarks
1	36072255010	CASING	1					
2	36072255020	COVER	1					
3	36072255030	GEAR (1)	1					
6	36072255060	DISK	1				EW0427	
	36073425030	DISK	1			EW0428		
7	36073425020	WHEEL,RATCHET	1					
8	36072255080	BUSH	1				EW0427	
	36073425040	BUSH	1			EW0428		
9	36072255091	RING,SLIP	1					
10	36072255101	RATCHET	1					
11	36072255110	PIN	1					
12	36072255120	SPRING	1					
13	36072255130	PIN	1					
14	36072255140	PLATE (LOCK)	1					
15	80172304010	SCREW,MACHINE	1		M4X10			
17	36072255160	BOLT (WITH WASHER)	6		M8X25			
19	36072255180	GAUGE,OIL	1					
20	36072255240	PLUG	1					
21	80500006004	BEARING,BALL	1					
22	80500006212	BEARING,BALL	1					
23	80500006305	BEARING,BALL	1					
24	80500006007	BEARING,BALL	1					
25	36072255190	KEY	2		7X7X20			
26	36072255250	O-RING	1					
27	91001101500	O-RING	1		1A P15			
28	36072255210	SEAL,OIL	1					
29	36072255220	NUT,CASTLE	1		M24			
30	80136350035	PIN,SPLIT	1		5X35			
31	80602110620	RING,RITAINING	1		R62			
41	36073435010	GEAR SET	1				EW0427	
	36073435011	GEAR SET	1			EW0428		
50	36073430000	WINCH (OOKUBO)	1					
101	36072251000	FACING KIT(JAPANESE)	1					
102	36072252000	FACING KIT (ENGLISH)	1					

TM-ZF500 31093010120A FRAME/SL,REMOTE-RADIO CONT.

Pos No.	Parts No	Parts Name	Qty	Unit	Technical Data	Serial No (Start)	Serial No (
1	(*****)	WINCH (SELF)	1				
2	(*****)	HOOK (SELF WINCH 10TON OPTION)	1				
3	(*****)	OPERATION SYSTEM, CONTROL VALVE	1				
4	(*****)	PIPING,WINCH	1				
6	31470511000	STOPPER,TIRE	4				
7	(*****)	PLATE ASSY,NAME (SELF WINCH,10TON)	1				
8	(*****)	ELEC.ASSY (SL)	1				
9	(*****)	RADIO CONTROL (KIT:MITSUMI)	1				

TM-ZF500 31093010120A FRAME/SL,REMOTE-RADIO CONT.

Pos No.	Parts No	Parts Name	Qty	Unit	Technical Data	Serial No (Start)	Serial No (End)	Remarks
1	36091929520	BODY ASSY	1					
2	80720104028	PIN,SPRING	1		4X28			
4	90303071801	WASHER,PLAIN	1		18			
5	12231505000	BEARING,PLAIN	1					
11	36091929510	HOOK ASSY	1					
12	90710008160	SCREW,SET	1		M8X16			
30	36094049510	STOPPER ASSY	1					
50	36091920000	HOOK (DRUM FREE,OPTION)	1					

TM-ZF500 31093010120A FRAME/SL,REMOTE-RADIO CONT.

Pos No.	Parts No	Parts Name	Qty	Unit	Technical Data	Serial No (Start)	Serial No (End)	Remarks	Pages
2	50620119000	PIN	1						
3	90101208014	BOLT	1		M8X14				
4	90302040801	WASHER,SPRING	1		8				
21	36090710000	HOOK (5TON)	1						000136
22	31478211100	PLATE,NAME	1						

TM-ZF500 31093010120A FRAME/SL,REMOTE-RADIO CONT.

Pos No.	Parts No	Parts Name	Qty	Unit	Technical Data	Serial No (Start)	Serial No (End)	Remarks	Pages
1	31440250100	ROLLER ASSY	1						
2	37000105740	PIN	2						
3	80136332020	PIN,SPLIT	2		3.2X20				
4	90303071001	WASHER,PLAIN	4		10				
5	37001300000	SPRING	2						
6	14124015000	BOLT	2						
7	90201201200	NUT	4		M12				
21	37001107470	ROLLER ASSY	2						
22	37001108310	ROLLER ASSY	1						
23	31440250300	PIN	1						
24	31440250150	SUPPORT	1						
25	31440150350	WASHER,PLAIN	2						
26	90286001007	NUT	2		M10 P=1.25				
31	80516006001	BEARING,BALL	4						

TM-ZF500 31093010120A FRAME/SL,REMOTE-RADIO CONT.
PG1130016-02 DETECTOR,BOOM LENGTH

60

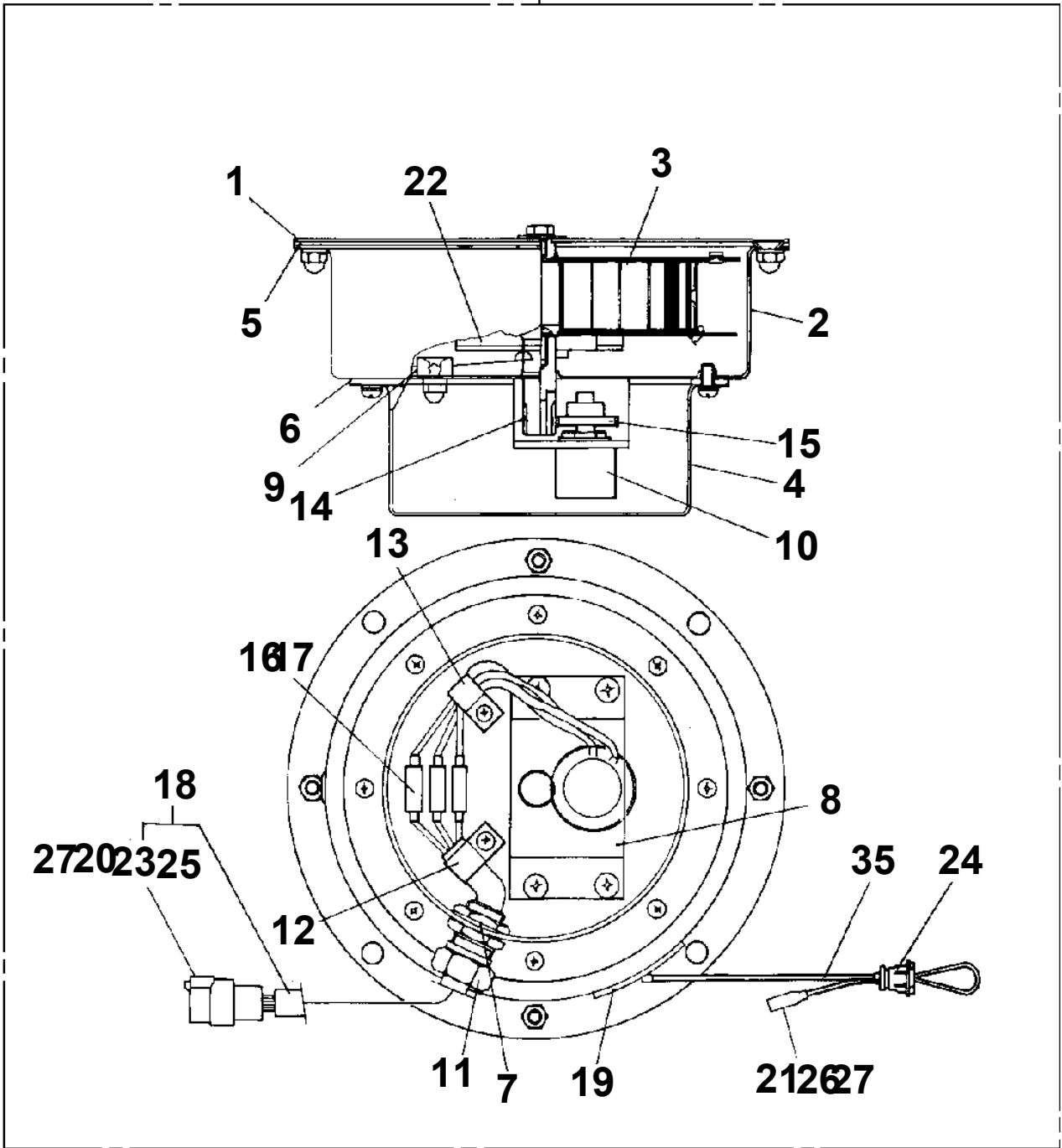

**TM-ZF500 31093010120A FRAME/SL,REMOTE-RADIO CONT.
PG1130144-01 DETECTOR,BOOM LENGTH (MOUNT)**

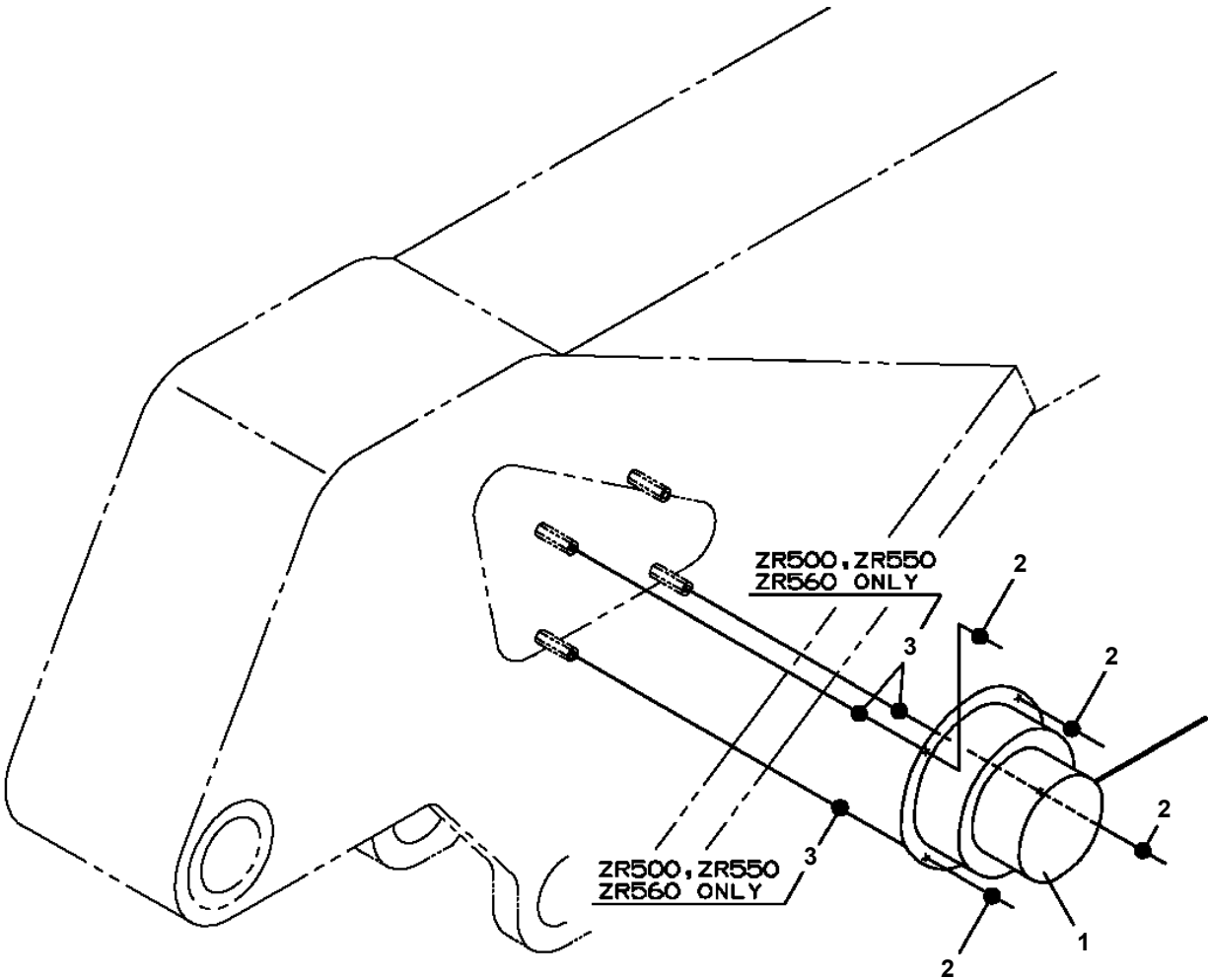

TM-ZF500 31093010120A FRAME/SL,REMOTE-RADIO CONT.
PH1100055-00 DETECTOR,OVER FRONT AREA

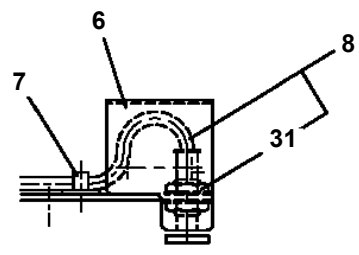
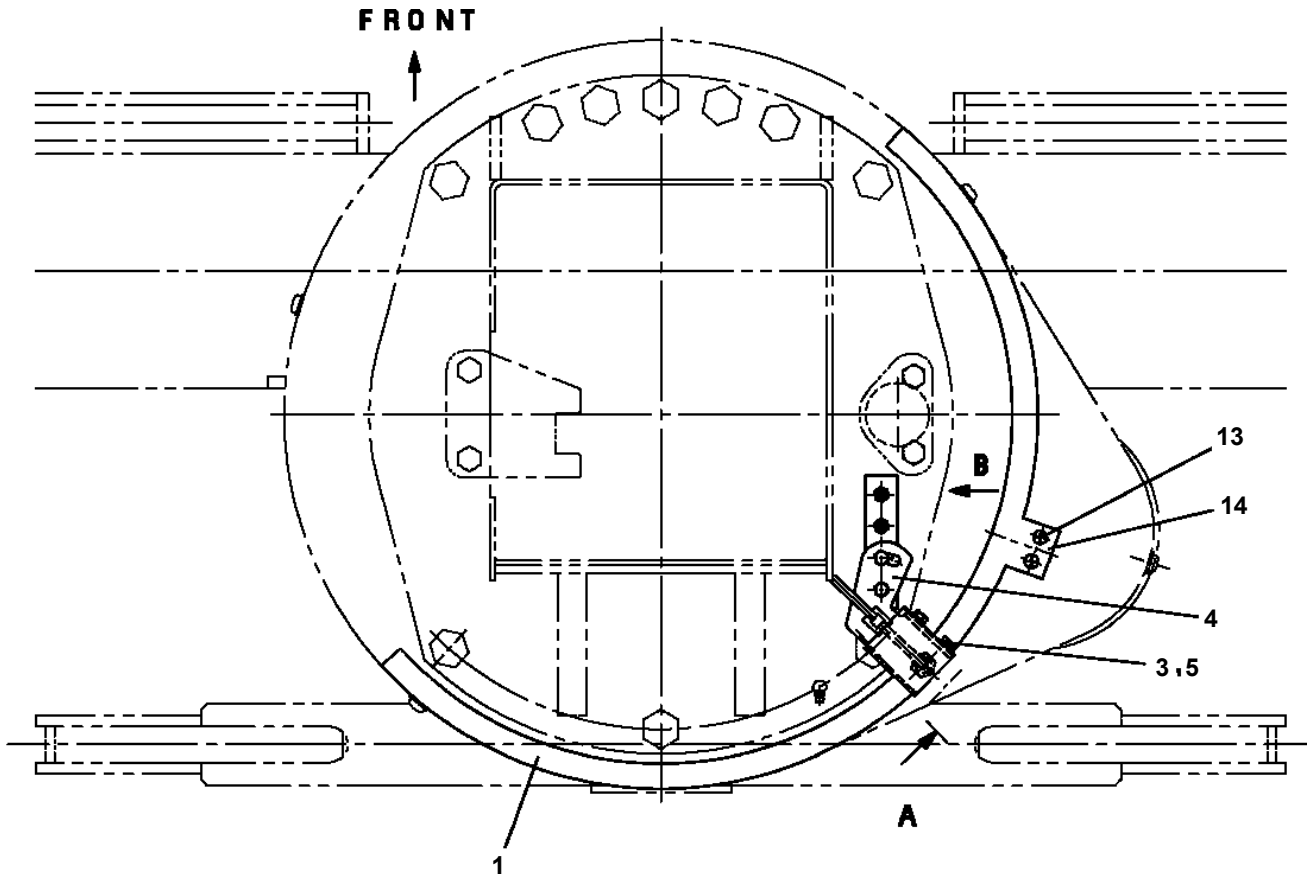

A

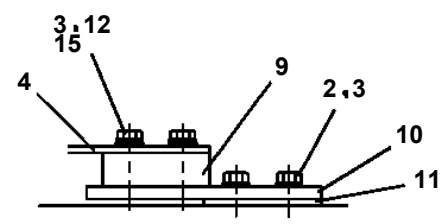

B

TM-ZF500 31093010120A FRAME/SL,REMOTE-RADIO CONT.
PH5032321-00 HARNESS

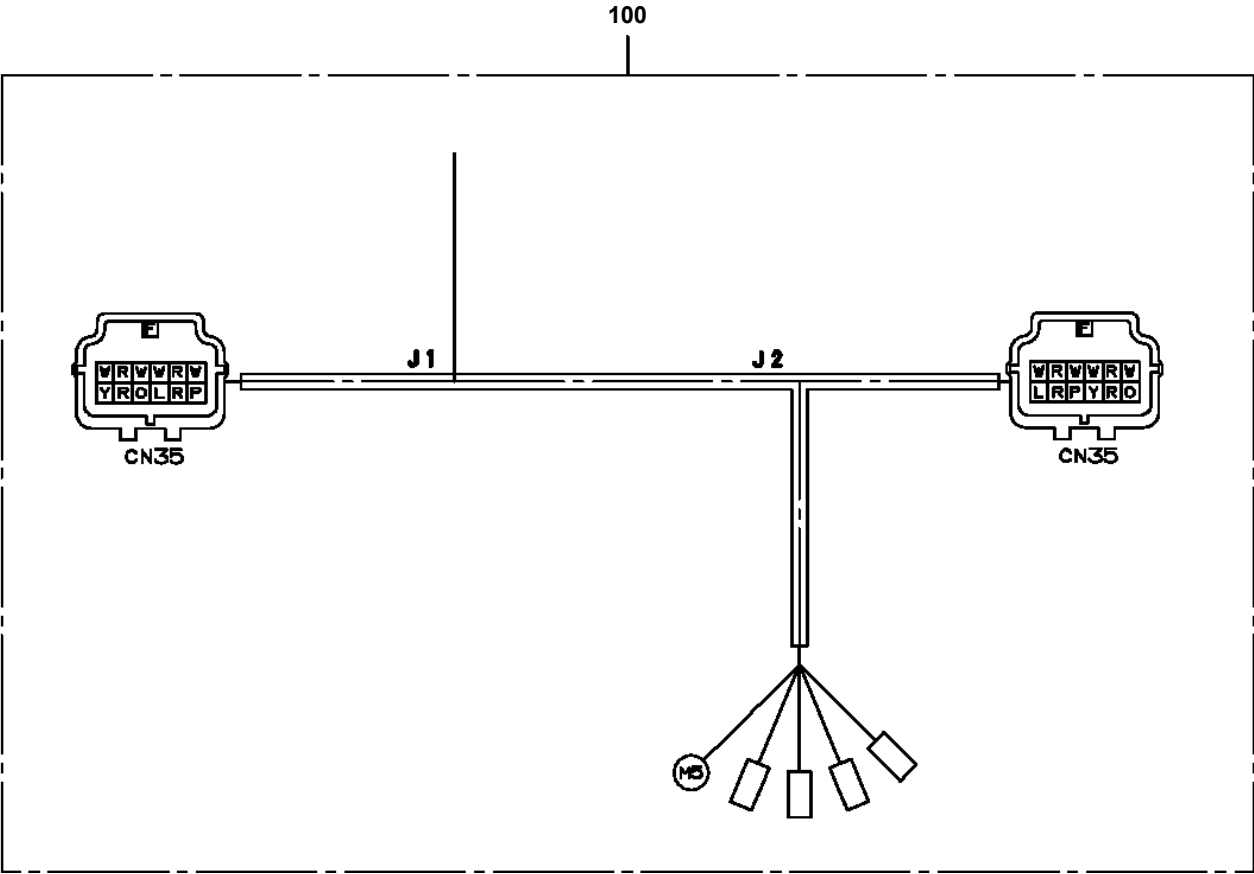

TM-ZF500 31093010120A FRAME/SL,REMOTE-RADIO CONT.
PI1010074-00 MOTOR,HYDRAULIC (SWING)

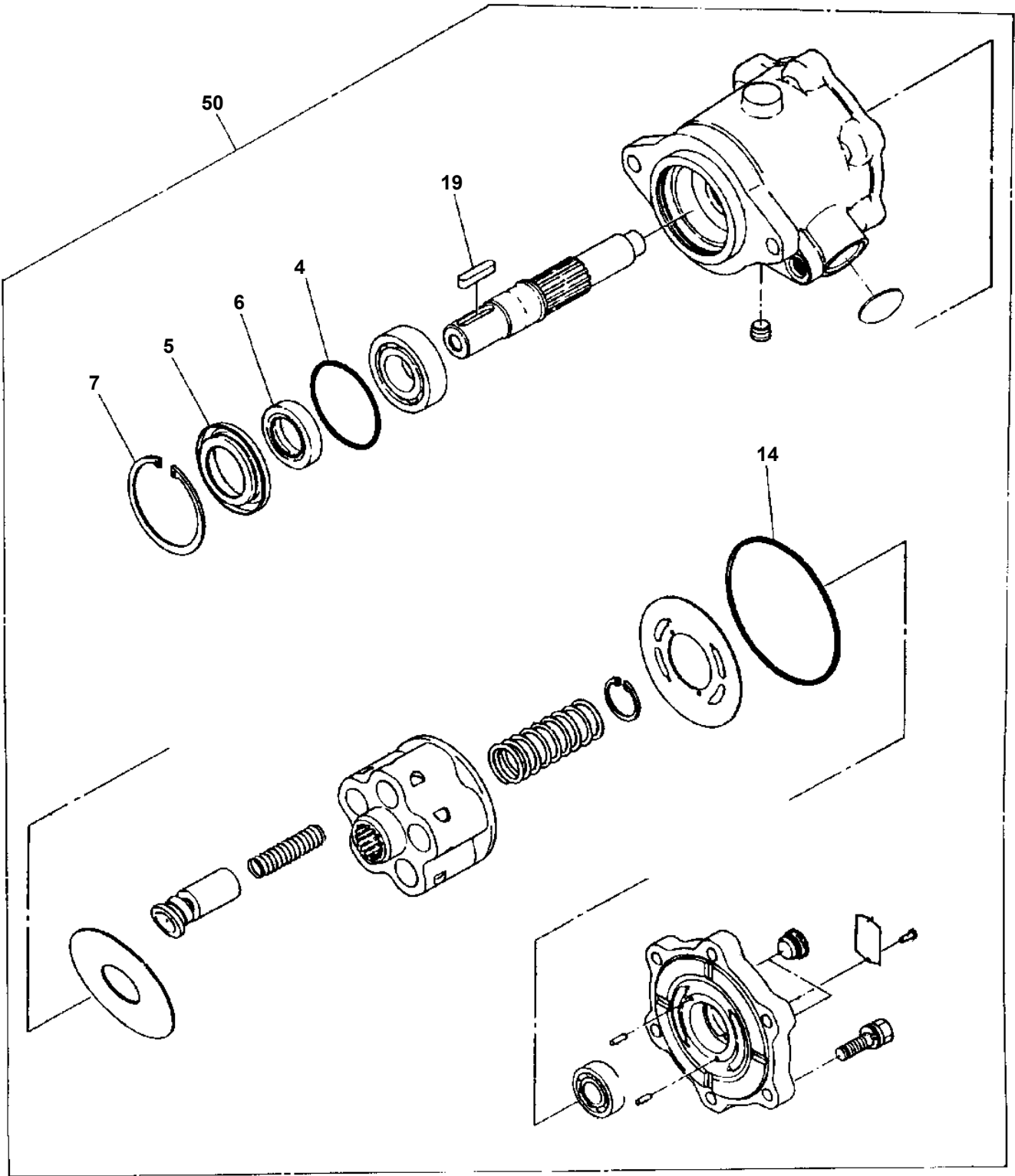

**TM-ZF500 31093010120A FRAME/SL,REMOTE-RADIO CONT.
PI1010152-00 MOTOR,HYDRAULIC (WINCH)**

50

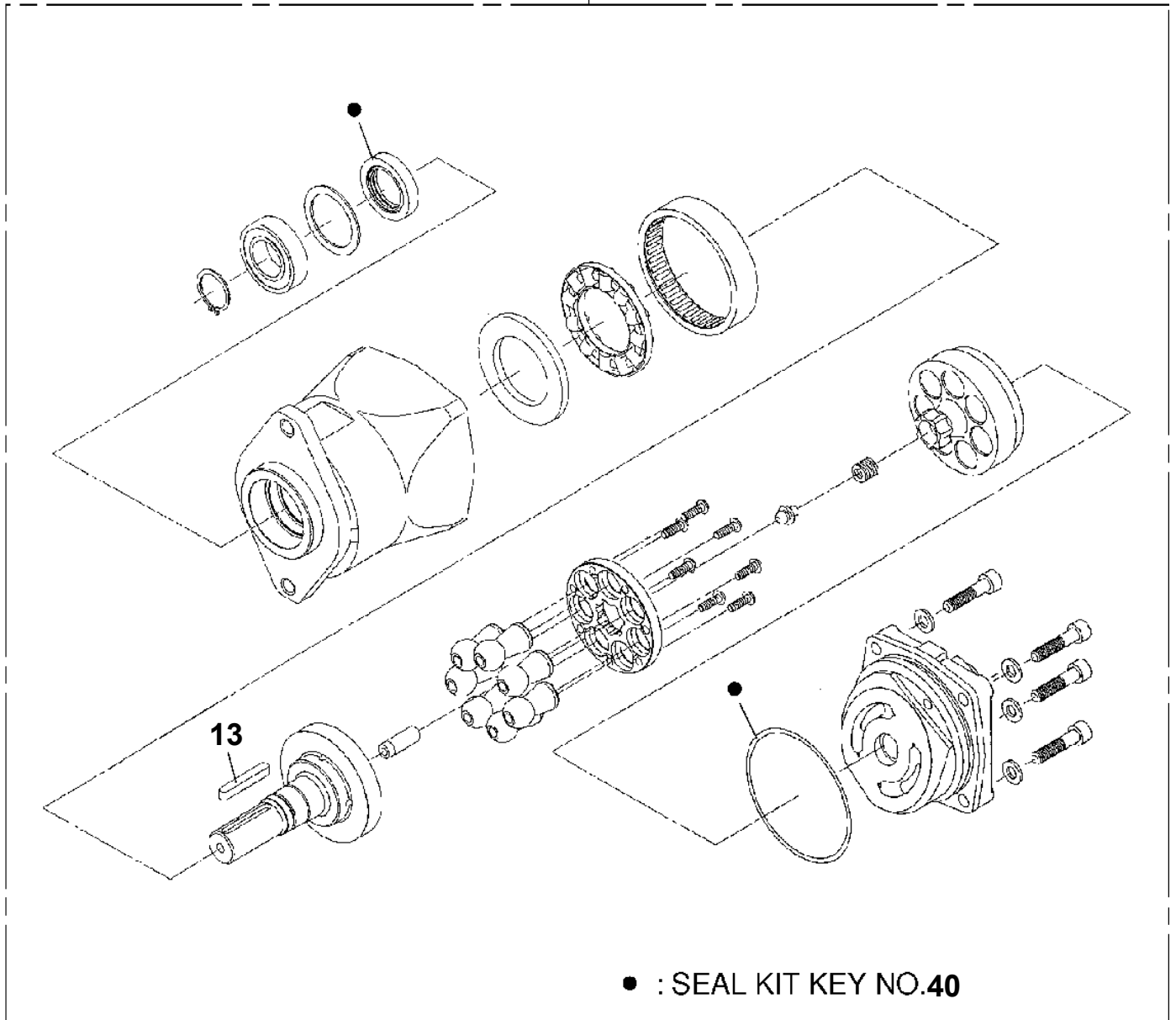

TM-ZF500 31093010120A FRAME/SL,REMOTE-RADIO CONT.
PI1250073-01 VALVE,COUNTERBALANCE (ELEVATING)

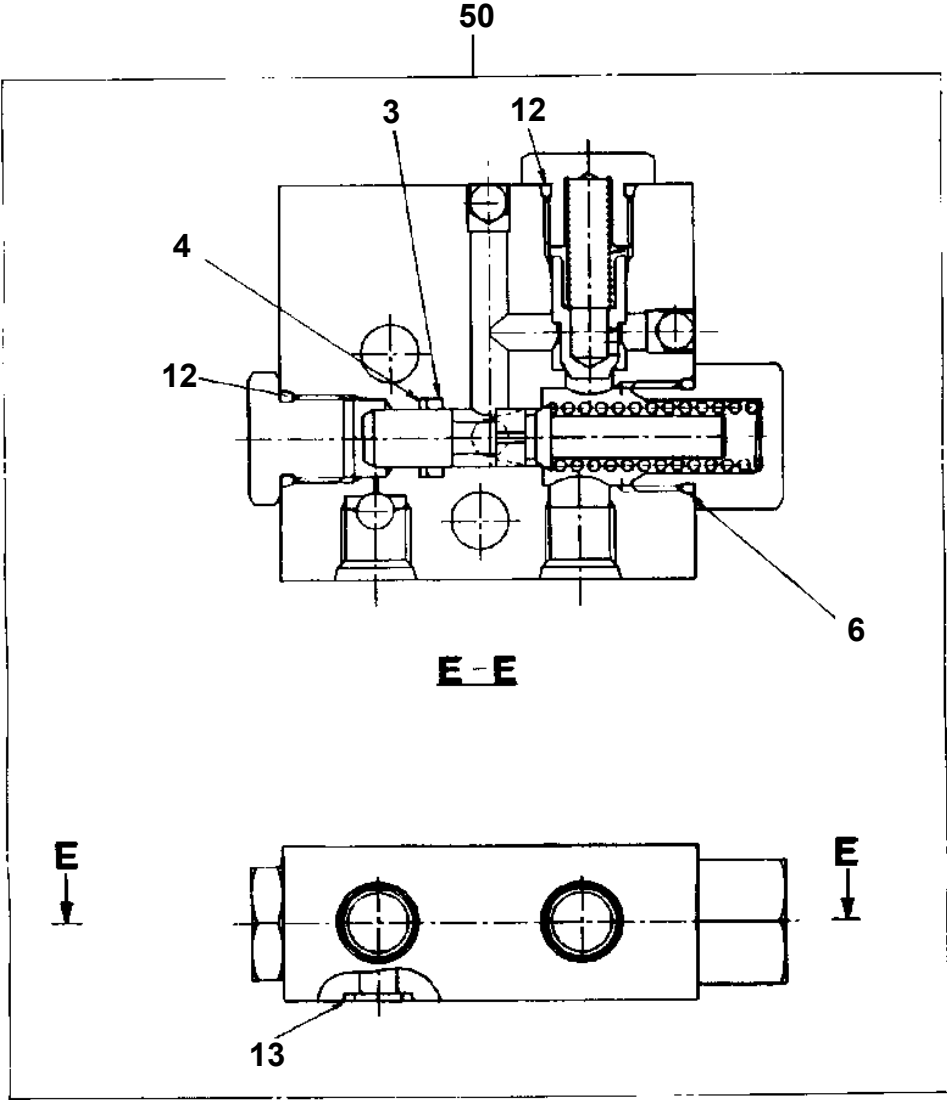

TM-ZF500 31093010120A FRAME/SL,REMOTE-RADIO CONT.
PI1300028-01 FILTER,OIL (CARTRIDGE)

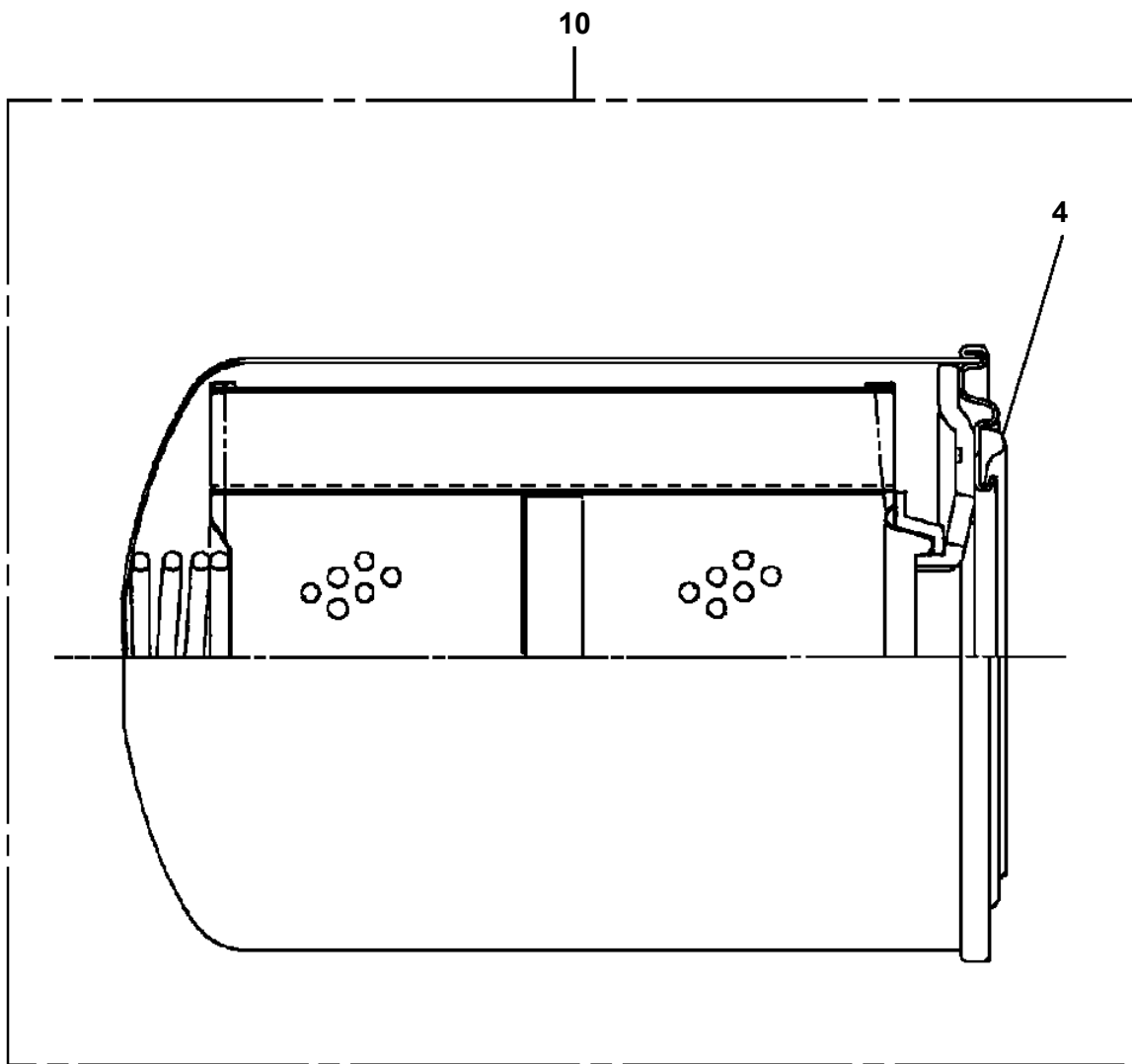

TM-ZF500 31093010120A FRAME/SL,REMOTE-RADIO CONT.
PI1440018-00 METER,LOAD (3.2TON KUSABA/ENGLISH)

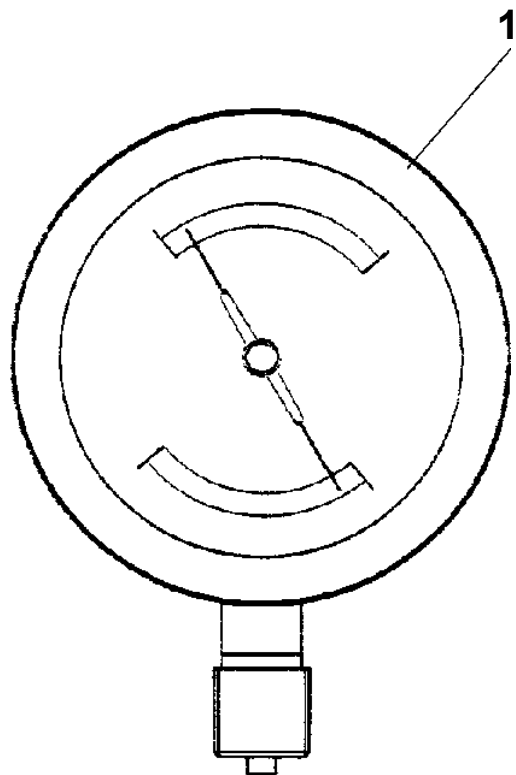

CLICK HERE TO **DOWNLOAD** THE COMPLETE MANUAL

- Thank you very much for reading the preview of the manual.
- You can download the complete manual from: www.heydownloads.com by clicking the link below



- Please note: If there is no response to CLICKING the link, please download this PDF first and then click on it.

CLICK HERE TO **DOWNLOAD** THE COMPLETE MANUAL

TM-ZF500 31093010120A FRAME/SL,REMOTE-RADIO CONT.
PK1010369-01 FRAME

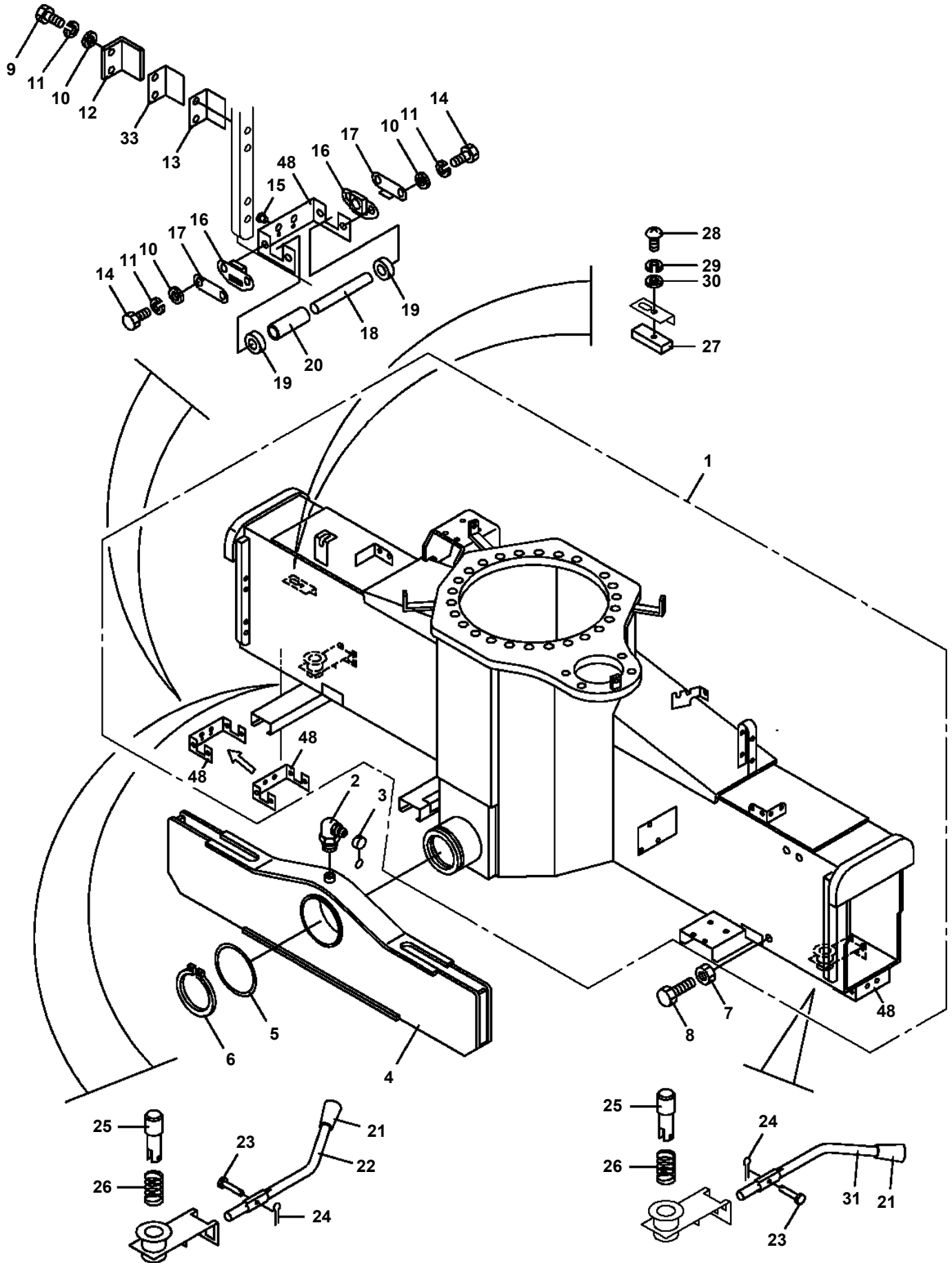

TM-ZF500 31093010120A FRAME/SL,REMOTE-RADIO CONT.

Pos No.	Parts No	Parts Name	Qty	Unit	Technical Data	Serial No (Start)	Serial No (End)	Re
83	90202200600	NUT	1		M6			
84	90101206020	BOLT	1		M6X20			
91	31322371100	SUPPORT	1					
92	31322050550	KNOB (RED)	1				EH2037	
	31322050560	KNOB (RED)	1			EH2038		
93	31322050500	KNOB (BLACK)	5				EH2037	
	31322050510	KNOB (BLACK)	5			EH2038		
94	31322373400	LEVER	1				EH2037	
	31322373401	LEVER	1			EH2038		
95	31322373150	LEVER	1				EH2037	
	31322373151	LEVER	1			EH2038		
96	31322373200	LEVER	1				EH2037	
	31322373201	LEVER	1			EH2038		
97	31322373250	LEVER	1				EH2037	
	31322373251	LEVER	1			EH2038		
98	37000136790	PIN ASSY	1					
99	80136340020	PIN,SPLIT	4		4X20			
100	37000155570	PIN ASSY	1					
101	37000301830	SPACER	1		L=16		EH4189	
	37000311190	SPACER	1		L=16	EH4190		
102	31322224200	PLATE	9		L=1		EH4189	
	31322224200	PLATE	6		L=1	EH4190		
103	31322053100	LEVER	1				EH2037	
105	31322052500	LEVER	1				EH2037	
	31322052501	LEVER	1			EH2038		
107	82440901030	PLUG	1					
109	37000310640	SPACER	1				EH4189	
112	90303071201	WASHER,PLAIN	1		12			
113	31322053101	LEVER	1			EH2038		
114	37000311520	SPACER	1		L=35	EH4190		
122	37000136800	PIN	1					
131	80136340020	PIN,SPLIT	1		4X20			
132	37000163020	PIN	1					

TM-ZF500 31093010120A FRAME/SL,REMOTE-RADIO CONT.
PN1011420-00 ELEC.ASSY (REMOTE CONTROL)

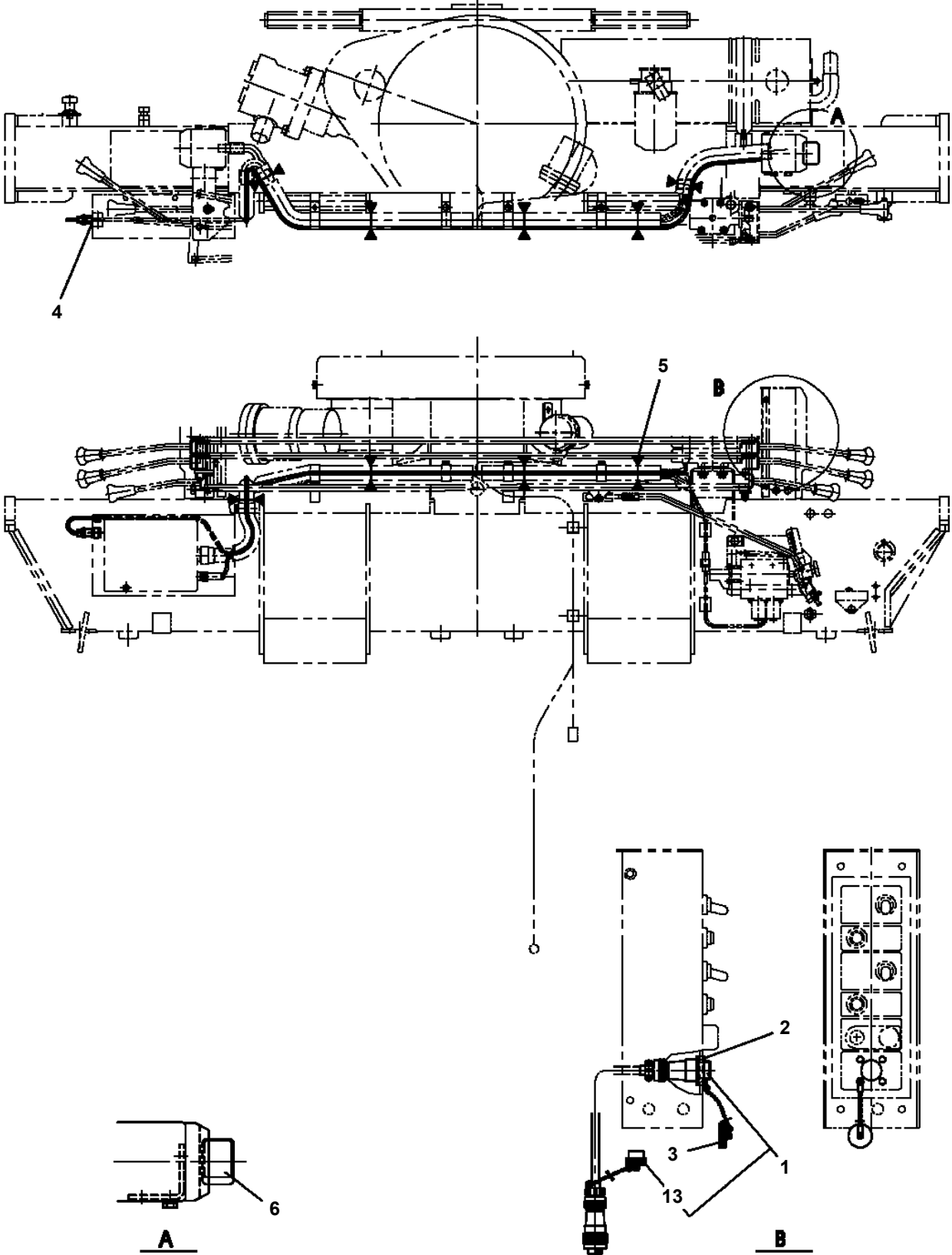

TM-ZF500 31093010120A FRAME/SL,REMOTE-RADIO CONT.

Pos No.	Parts No	Parts Name	Qty	Unit	Technical Data	Serial No (Start)	Serial No (End)	Remarks	Page
1	82401601002	CLAMP	6						
2	91810130250	FASTENER	7						
4	90101206010	BOLT	8		M6X1.0				
5	90302040601	WASHER,SPRING	8		6				
6	90303070601	WASHER,PLAIN	4		6				
7	31473744200	SUPPORT	2						
8	90302040801	WASHER,SPRING	2		8				
9	31473462500	HARNESS	1						
10	31473744500	HARNESS	1						
11	31380171500	HARNESS	1						
12	31473744700	HARNESS (L=1000)	2						00015
13	31473744900	SUPPORT	2						
14	90101208012	BOLT	2		M8X12				
15	91810130240	FASTENER	6						
31	31473744110	PANEL	2						
32	31473744150	SWITCH ASSY	2						
33	82197600103	CAP (RED)	2						
34	31473744160	PLATE,NAME	2						
35	31473744170	COVER	2						
36	80172803008	SCREW,MACHINE	4		M3X8				
41	82101419002	SWITCH,PUSH	2						

**TM-ZF500 31093010120A FRAME/SL,REMOTE-RADIO CONT.
PN1011470-05 ELEC.ASSY (REMOTE CONTROL)**

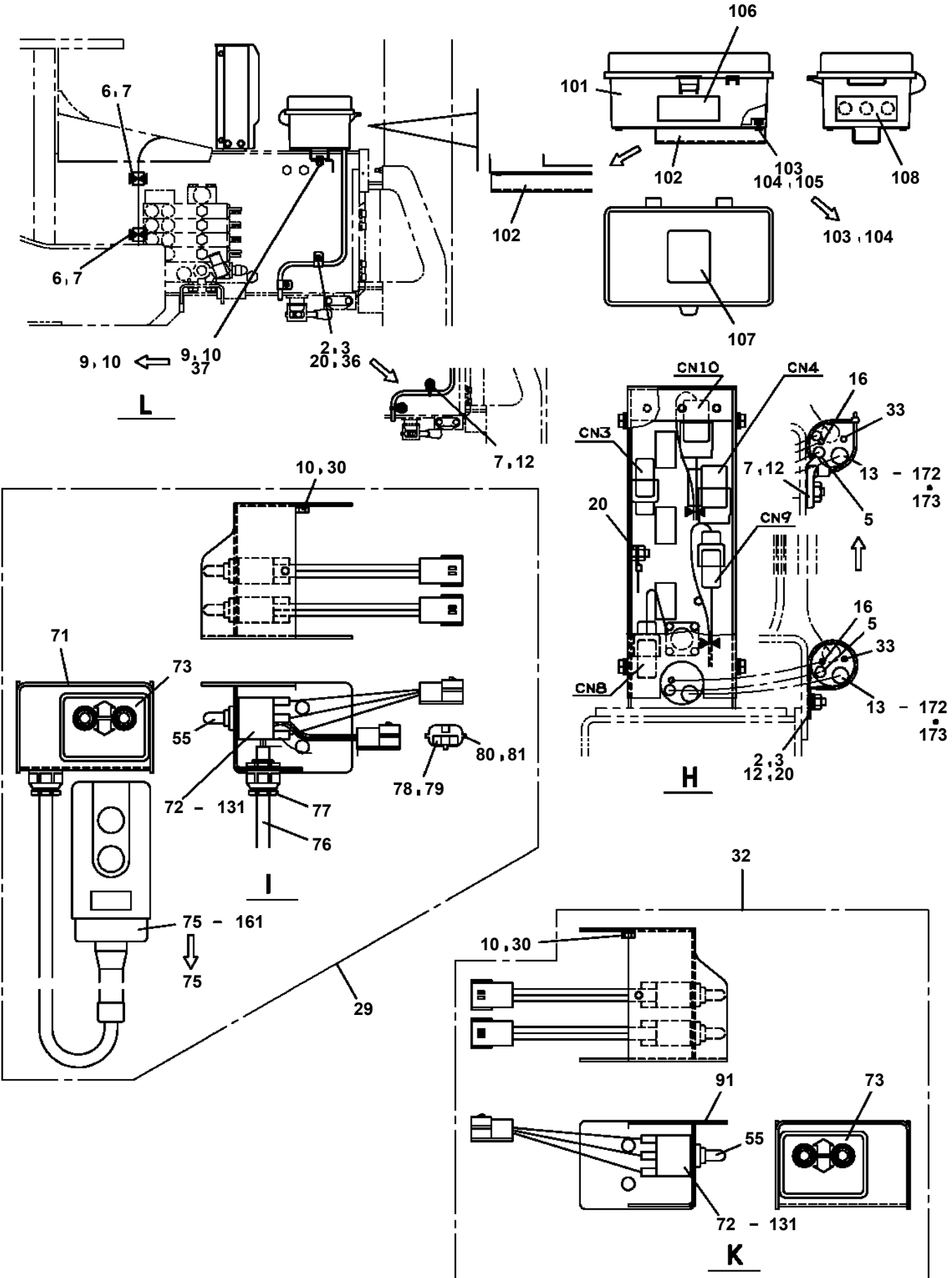

TM-ZF500 31093010120A FRAME/SL,REMOTE-RADIO CONT.
PN1011778-01 ELEC.ASSY (LOWAR)

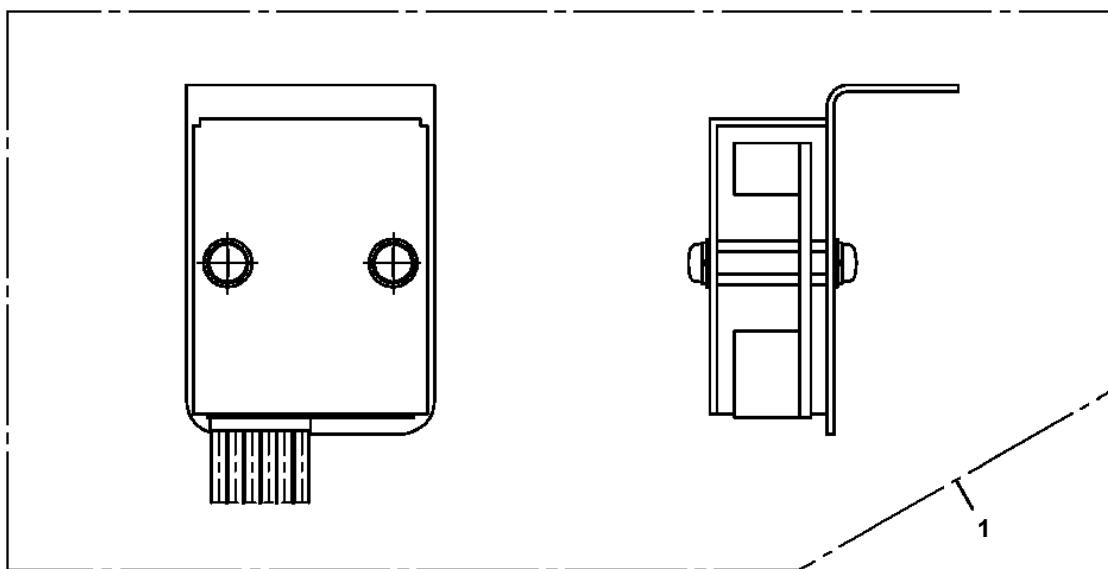
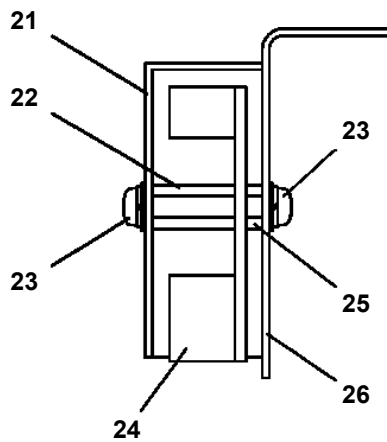
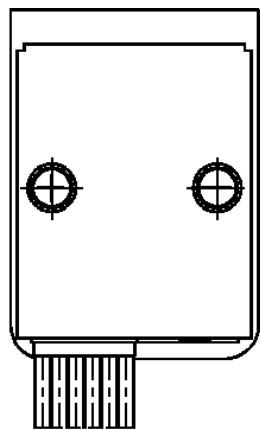

F



TM-ZF500 31093010120A FRAME/SL,REMOTE-RADIO CONT.
PN1011895-00 ELEC.ASSY (OIL COOLER/OPT.)

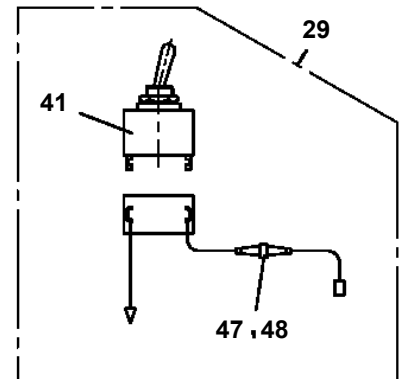
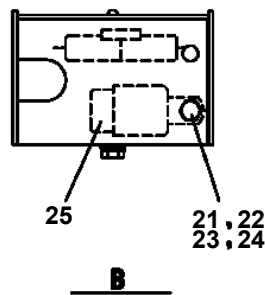
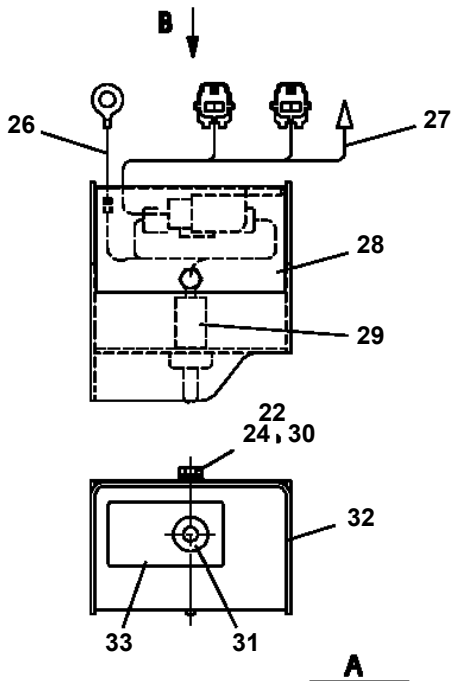
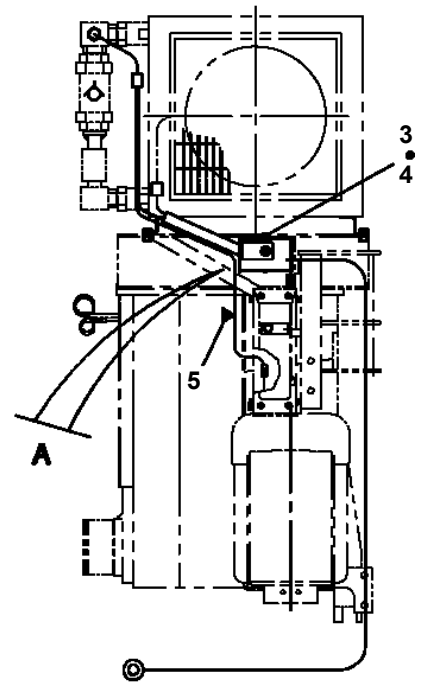
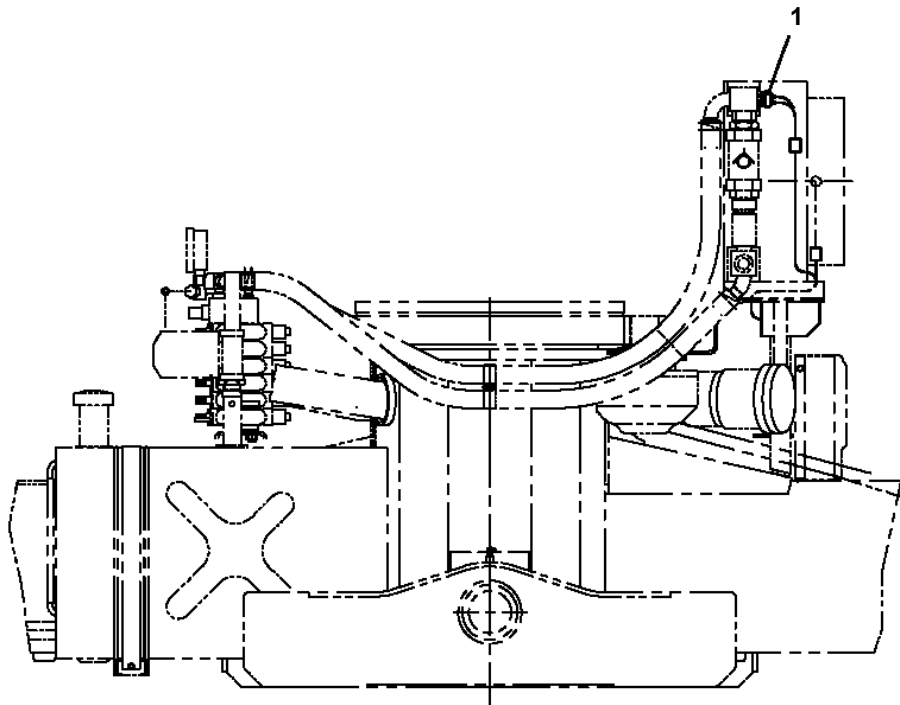
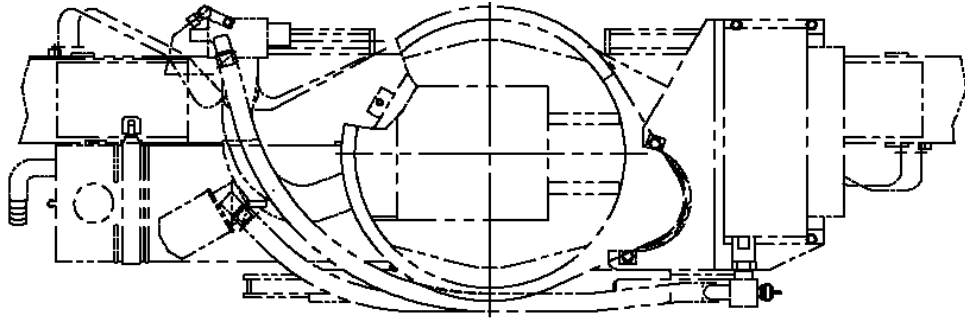

TM-ZF500 31093010120A FRAME/SL,REMOTE-RADIO CONT.

Pos No.	Parts No	Parts Name	Qty	Unit	Technical Data	Serial No (Start)	Serial No (End)	Remarks	Pages
1	31653110100	SUPPORT	1						
2	90101210014	BOLT	2		M10X14				
3	90302041001	WASHER,SPRING	2		10				
4	90101206075	BOLT	4		M6X75				
5	90302040601	WASHER,SPRING	4		6				
6	90303070601	WASHER,PLAIN	8		6				
7	90201200600	NUT	4		M6				
8	91850310305	CLAMP	4						
9	91810130240	FASTENER	8						
10	82401600510	CLAMP	1		10				
11	31653110200	CABLE ASSY	1		L=2000				
21	82100002385	CONNECTOR	2						

TM-ZF500 31093010120A FRAME/SL,REMOTE-RADIO CONT.
PN1012772-01 ELEC.ASSY (ALARM,UPPER)

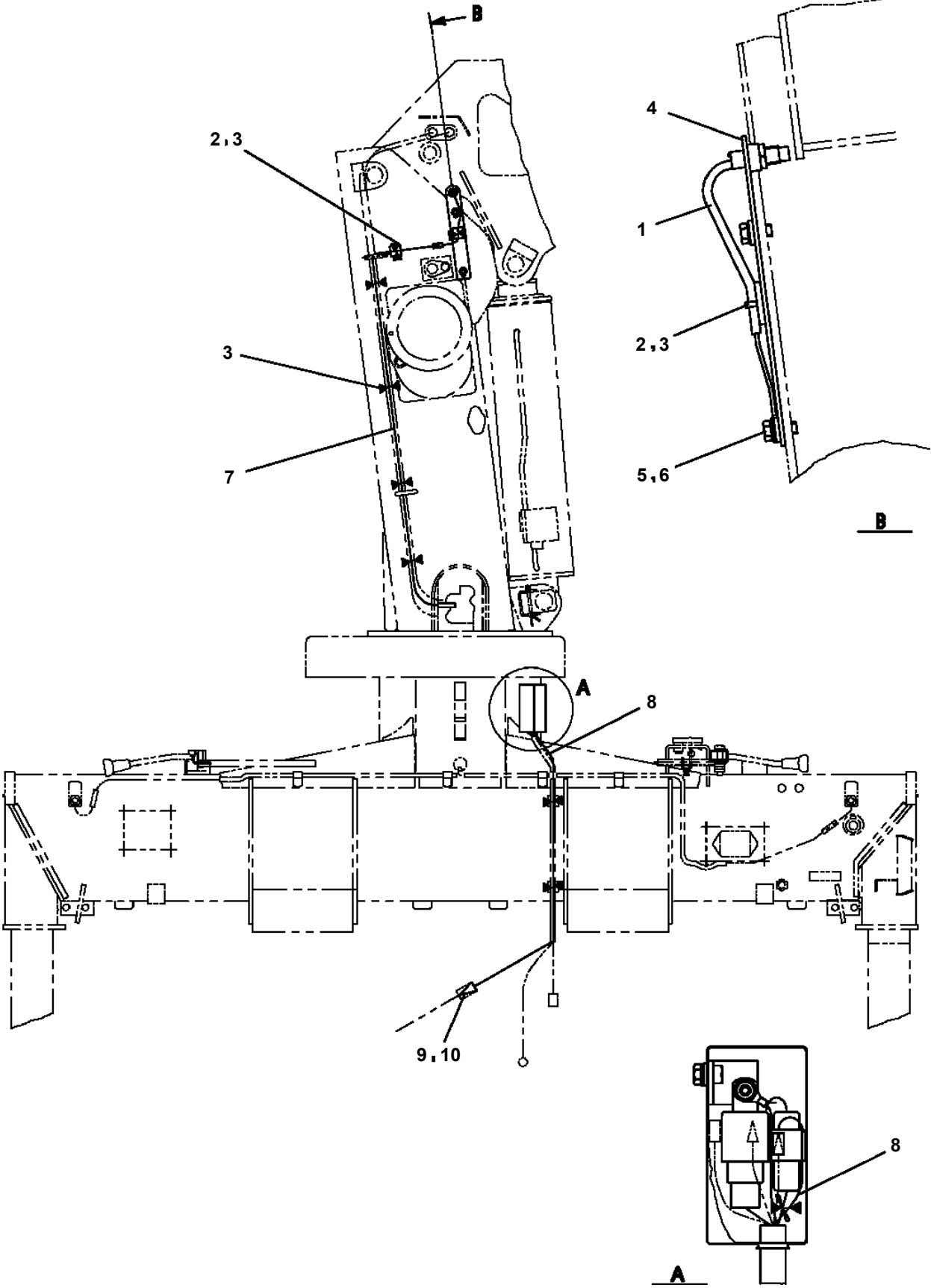

TM-ZF500 31093010120A FRAME/SL,REMOTE-RADIO CONT.

Pos No.	Parts No	Parts Name	Qty	Unit	Technical Data	Serial No (Start)	Serial No (End)
1	91850310405	CLAMP (BLACK)	8				
2	91810130250	FASTENER	20				
3	31360201101	HARNESS	1				
4	31360191200	SUPPORT	1				
5	90203201200	NUT	1		M12		
6	36140470000	DETECTOR,BOOM ANGLE	1				
7	90186206010	BOLT,FLANGE	24		M6X10		
8	31360741300	LAMP ASSY	2				
9	82100002014	CLAMP	2		WR20		
10	31652030200	BUZZER ASSY	1				
11	31360191010	COVER (CORRUGATE TUBE)	1		L=1500		
12	90303070601	WASHER,PLAIN	4		6		
13	82100002596	RELAY	1				
14	90101205010	BOLT	4		M5X10		
15	90302040501	WASHER,SPRING	4		5		
16	31361112100	COVER ASSY	1				
17	31361661100	HARNESS	1				
18	31360741600	SUPPORT	2				
19	31360741700	SUPPORT	1				
20	31653303200	SWITCH ASSY (NIHON AUTOMATIC)	1				
21	82197600101	CAP (BLACK)	1				
22	90201200600	NUT	2		M6		
23	90302040601	WASHER,SPRING	2		6		
41	82199444326	LAMP (YELLOW) <24V 12W)	2				
42	31360741310	SUPPORT	2				
51	31361112110	COVER	1				
52	31361112120	PLATE	1				
53	31361112130	SEAL	1				
61	82101940130	SWITCH,PUSH (3PJW106F-021-CC)	1				

TM-ZF500 31093010120A FRAME/SL,REMOTE-RADIO CONT.

Pos No.	Parts No	Parts Name	Qty	Unit	Technical Data	Serial No (Start)	Serial No (End)	Re
1	31476362102	ALARM ASSY (ASSY ONLY)	1				EH8710	
	31476362103	ALARM ASSY (ASSY ONLY)	1			EH8711	PA1677	
	31476362104	ALARM ASSY (ASSY ONLY)	1			PA1678		
2	31475352100	PLATE,NAME	1					
3 *	31476362200	HARNESS (WHITE)	1		L=6000		EH7924	See act
	31476362500	RELAY ASSY	1			EH7925	PA1677	
	31477472200	RELAY ASSY	1			PA1678		
4	31380174000	LAMP ASSY (ASSY ONLY)	1					
5	82100000191	TERMINAL	4					
6	82100000183	INSULATOR	4					
7	91810130240	FASTENER	10					
8	82115001002	CONNECTOR	4					
	82115001002	CONNECTOR	9			EH7925		
9 *	82100001400	TERMINAL	3				EH7924	See act
	82100001400	TERMINAL	6			EH7925		
10	31475982100	PLATE,CAUTION	1				EH7924	
	31476362700	PLATE,CAUTION	1			EH7925		
11	31380292600	SUPPORT	1					
12	80172305020	SCREW,MACHINE	2		M5X20			
13	90302040501	WASHER,SPRING	2		5			
14	90303070501	WASHER,PLAIN	2		5			
15 *	31476362400	HARNESS (RED)	2		L=6000		EH7924	See act
	31476362600	RELAY ASSY	2			EH7925	PA1677	
	31476364000	RELAY ASSY	2			PA1678		
16 *	82100001220	INSULATOR	3				EH7924	See act
	82100001220	INSULATOR	6			EH7925		
17	31476362300	RELAY ASSY	1				PA1677	
	31504322200	RELAY ASSY	1			PA1678		
18	31475982400	DIODE ASSY	1					
19	82100000192	TERMINAL	1					
20	82100000182	INSULATOR	1					
21	90928040101	SCREW,TAPPING	3		M4X10			
23	82115001005	CONNECTOR	9					

TM-ZF500 31093010120A FRAME/SL,REMOTE-RADIO CONT.
PN1350004-01 REEL,CORD

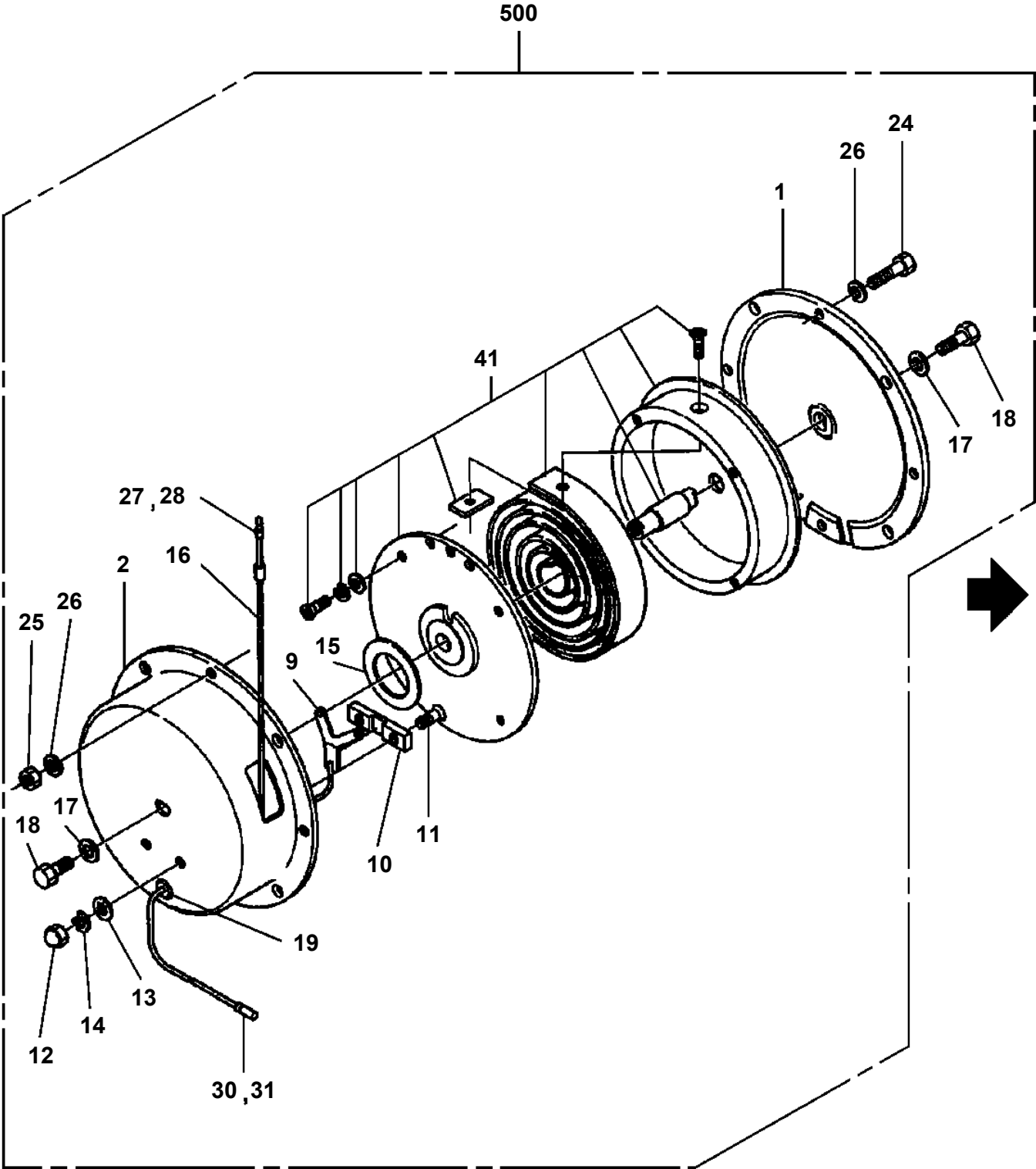

TM-ZF500 31093010120A FRAME/SL,REMOTE-RADIO CONT.

Pos No.	Parts No	Parts Name	Qty	Unit	Technical Data	Serial No (Start)	Serial No (End)	Remarks
1	12437013001	PLATE,NAME	1					
2	37002213820	PLATE,NAME	1					
3	37002206490	PLATE,NAME (GREASE)	3					
4	37002213060	PLATE,NAME (WINCH)	1					
5	31394550200	PLATE,CAUTION	1					

TM-ZF500 31093010120A FRAME/SL,REMOTE-RADIO CONT.

Pos No.	Parts No	Parts Name	Qty	Unit	Technical Data	Serial No (Start)	Serial No (End)	Re
1	37002213050	PLATE,NAME (TELESCOPING)	1					
2	37002213060	PLATE,NAME (WINCH)	1					
3	37002213070	PLATE,NAME (ELEVATING)	1					
4	37002213080	PLATE,NAME (SWING)	2					
5	37002214830	PLATE,NAME (TELESCOPING)	2					
6	37002213110	PLATE,NAME	1					
7	37002214820	PLATE,NAME (O/R EXTENSION)	2					
8	37002213120	PLATE,NAME (TELESCOPING)	1					
9	37002213130	PLATE,NAME (WINCH)	1					
10	37002213140	PLATE,NAME (ELEVATING)	1					
11	37002213170	PLATE,NAME	1					
12	37002200320	PLATE,NAME	2					
14	90451700100	SCREW,TAPPING	4		M4X6.4			
15	31395390210	PLATE,CAUTION	2					
16	31395220230	PLATE,CAUTION	2					
17	37002206490	PLATE,NAME (GREASE)	5					
18	37002214020	PLATE,NAME (SLIDE)	1					
19	37002214030	PLATE,NAME (SLIDE)	1					
20	31395220250	PLATE,CAUTION	2					
21	31395220260	PLATE,CAUTION	2					
22	37002217510	PLATE,CAUTION (LOCK)	1					
23	37002217520	PLATE,CAUTION (LOCK)	1					
31	37002213190	PLATE,NAME (LEVEL,ISO VG46)	1					
32	37002213740	PLATE,NAME (LEVEL,ISO VG32)	1					

TM-ZF500 31093010120A FRAME/SL,REMOTE-RADIO CONT.

Pos No.	Parts No	Parts Name	Qty	Unit	Technical Data	Serial No (Start)	Serial No (End)	Remarks	P
1	31500512100	PLATE,CAUTION (AWL)	1						
3	31361473100	PLATE,NAME	2						

TM-ZF500 31093010120A FRAME/SL,REMOTE-RADIO CONT.

Pos No.	Parts No	Parts Name	Qty	Unit	Technical Data	Serial No (Start)	Serial No (End)	Remarks	Pages
1	31395392100	PLATE,NAME	1						
2	31395392200	PLATE,NAME	1						
3	31395392301	PLATE,NAME	2						
4	31395392401	PLATE,NAME	1						
5	37002215730	PLATE,NAME	1						
6	31392140130	INDICATOR	2						
7	90190000060	BOLT	2		M10X16				

TM-ZF500 31093010120A FRAME/SL,REMOTE-RADIO CONT.

Pos No.	Parts No	Parts Name	Qty	Unit	Technical Data	Serial No (Start)	Serial No (End)	Remarks	Pages
1	31395461100	PLATE,NAME	1						
2	31395461200	PLATE,NAME	1						
3	31395461301	PLATE,NAME	2						
4	31395461401	PLATE,NAME	1						
5	37002215750	PLATE,NAME	1						
6	31392140130	INDICATOR	2						
7	90190000060	BOLT	2		M10X16				

TM-ZF500 31093010120A FRAME/SL,REMOTE-RADIO CONT.

Pos No.	Parts No	Parts Name	Qty	Unit	Technical Data	Serial No (Start)	Serial No (End)	Remarks	Pages
1	31395473100	PLATE,NAME	1						
2	31395473200	PLATE,NAME	1						
3	31395473300	PLATE,NAME	2						
4	31395473400	PLATE,NAME	1						
5	37002215760	PLATE,NAME	1						
6	31392140130	INDICATOR	2						
7	90190000060	BOLT	2		M10X16				

TM-ZF500 31093010120A FRAME/SL,REMOTE-RADIO CONT.

Pos No.	Parts No	Parts Name	Qty	Unit	Technical Data	Serial No (Start)	Serial No (End)
2	31631807510	CASE (RING)	1				
4	31631807520	SPACER	1				
11	31631807530	CLAMP (CABLE)	1				
15	31631807540	O-RING	1				
16	31631807550	PACKING	1				
101	31631807560	HOLDER ASSY,BRUSH (WITH BRUSH)	1				
900	31631803000	RING ASSY,SLIP	1				

TM-ZF500 31093010120A FRAME/SL,REMOTE-RADIO CONT.

Pos No.	Parts No	Parts Name	Qty	Unit	Technical Data	Serial No (Start)	Serial No (End)
1	36800582000	SWITCH BOX (REMOTE CONTROL.M2)	1				
2	(*****)	STOWING BOX (REMOTE CONTROL)	1				
3	(*****)	ELEC.ASSY (REMOTE CONTROL)	1				

TM-ZF500 31093010120A FRAME/SL,REMOTE-RADIO CONT.
PV1020100-05 VALVE,REMOTE CONTROL (SANWA)

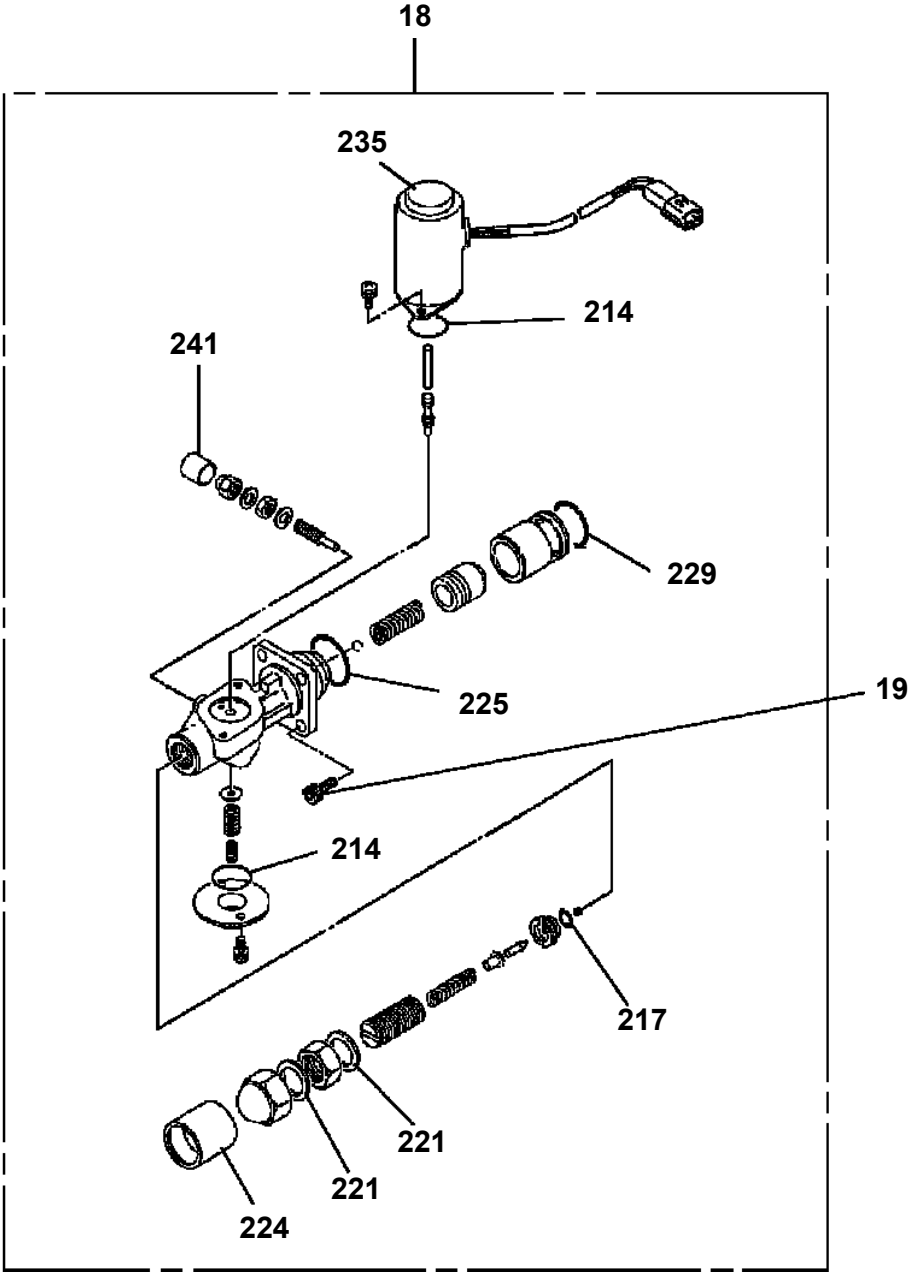

**TM-ZF500 31093010120A FRAME/SL,REMOTE-RADIO CONT.
PV1020119-02 VALVE,REMOTE CONTROL (NACHI)**

- 71 TELESCOPING
- 91 WINCH
- 101 ELEVATING
- 111 SWING

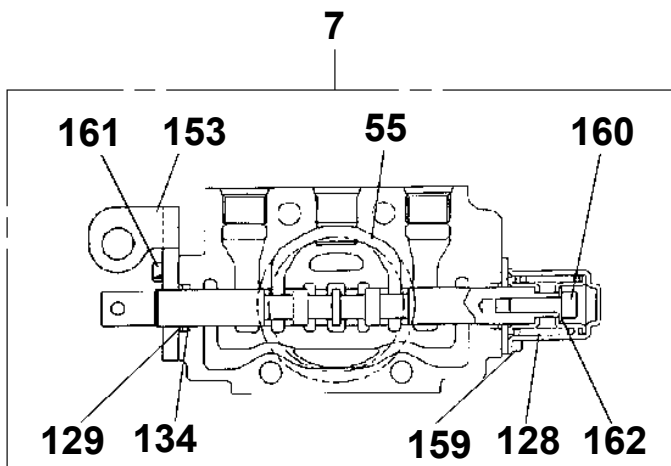
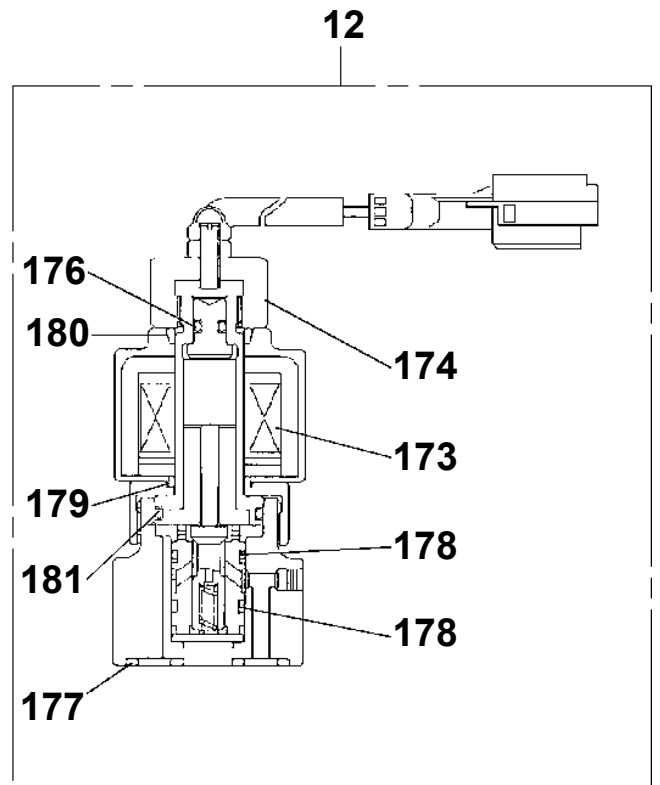
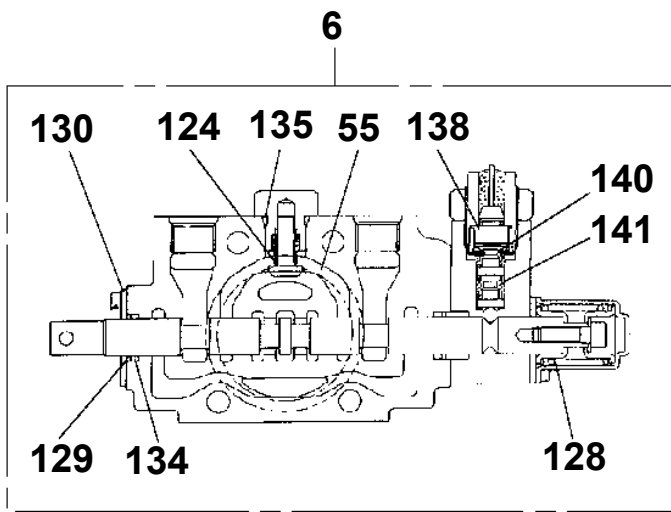
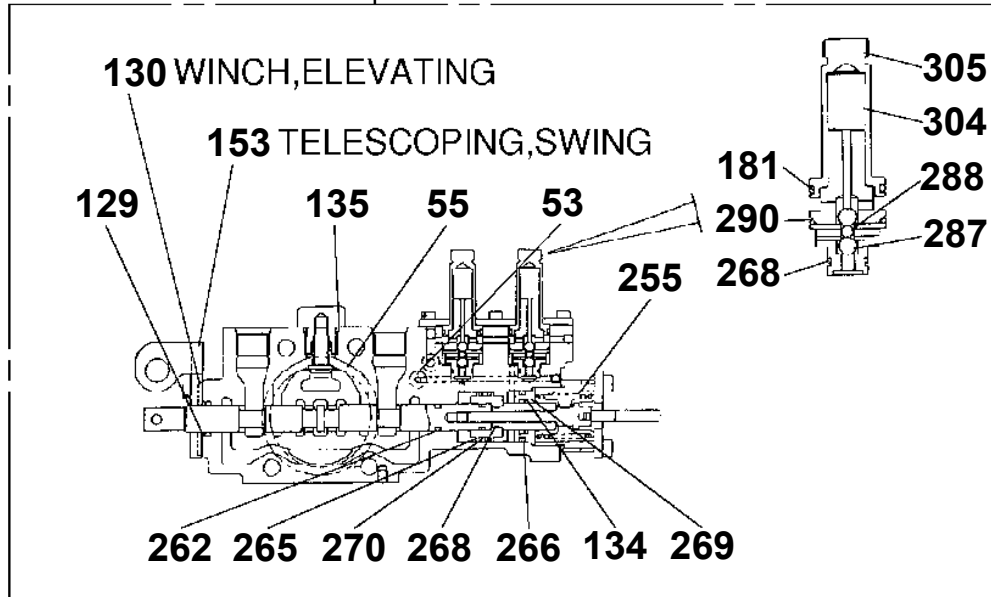

TM-ZF500 31093010120A FRAME/SL,REMOTE-RADIO CONT.
PV1020252-00 VALVE,REMOTE CONTROL

300

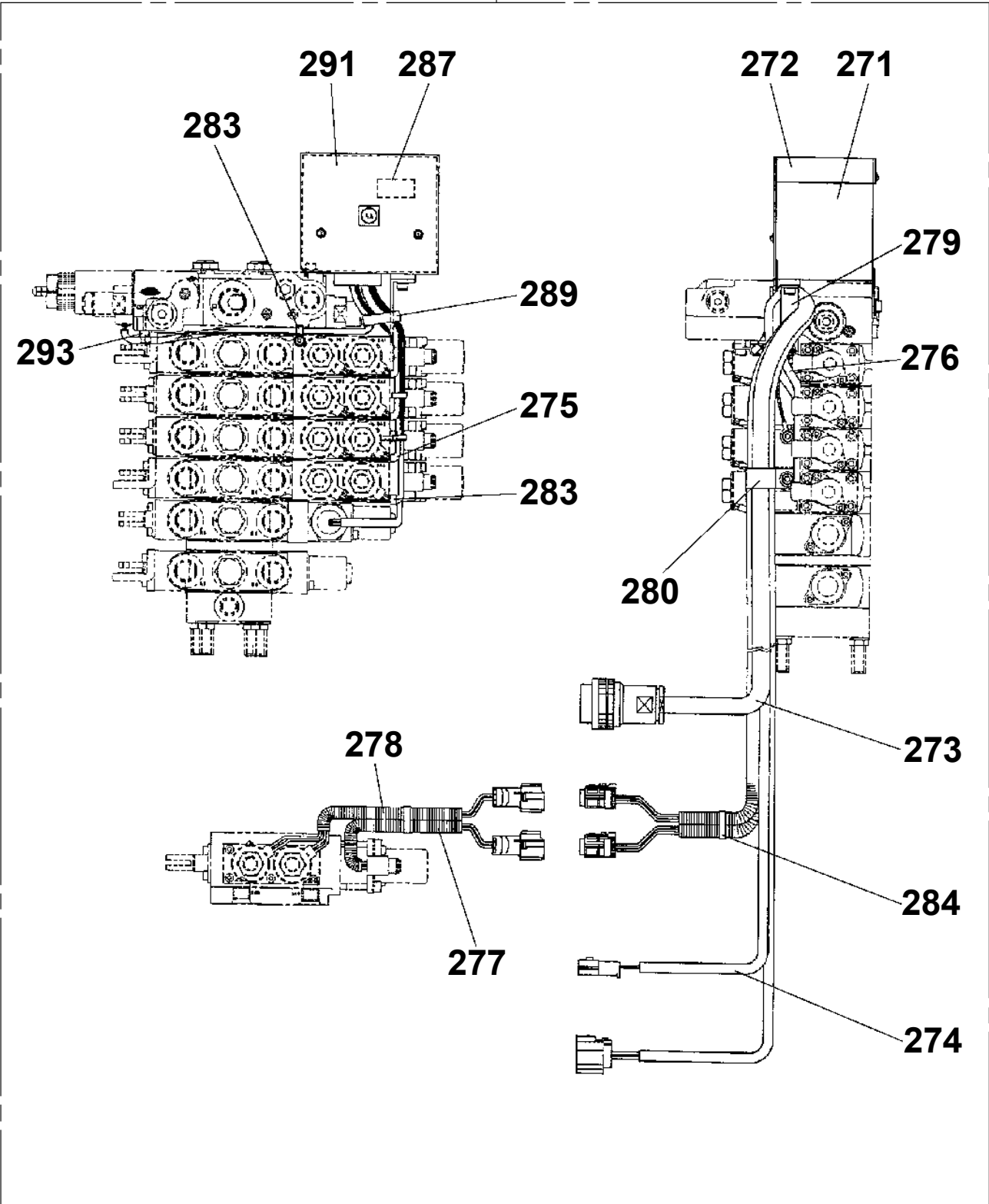

TM-ZF500 31093010120A FRAME/SL,REMOTE-RADIO CONT.
 PV1020366-00 VALVE,REMOTE CONTROL

900

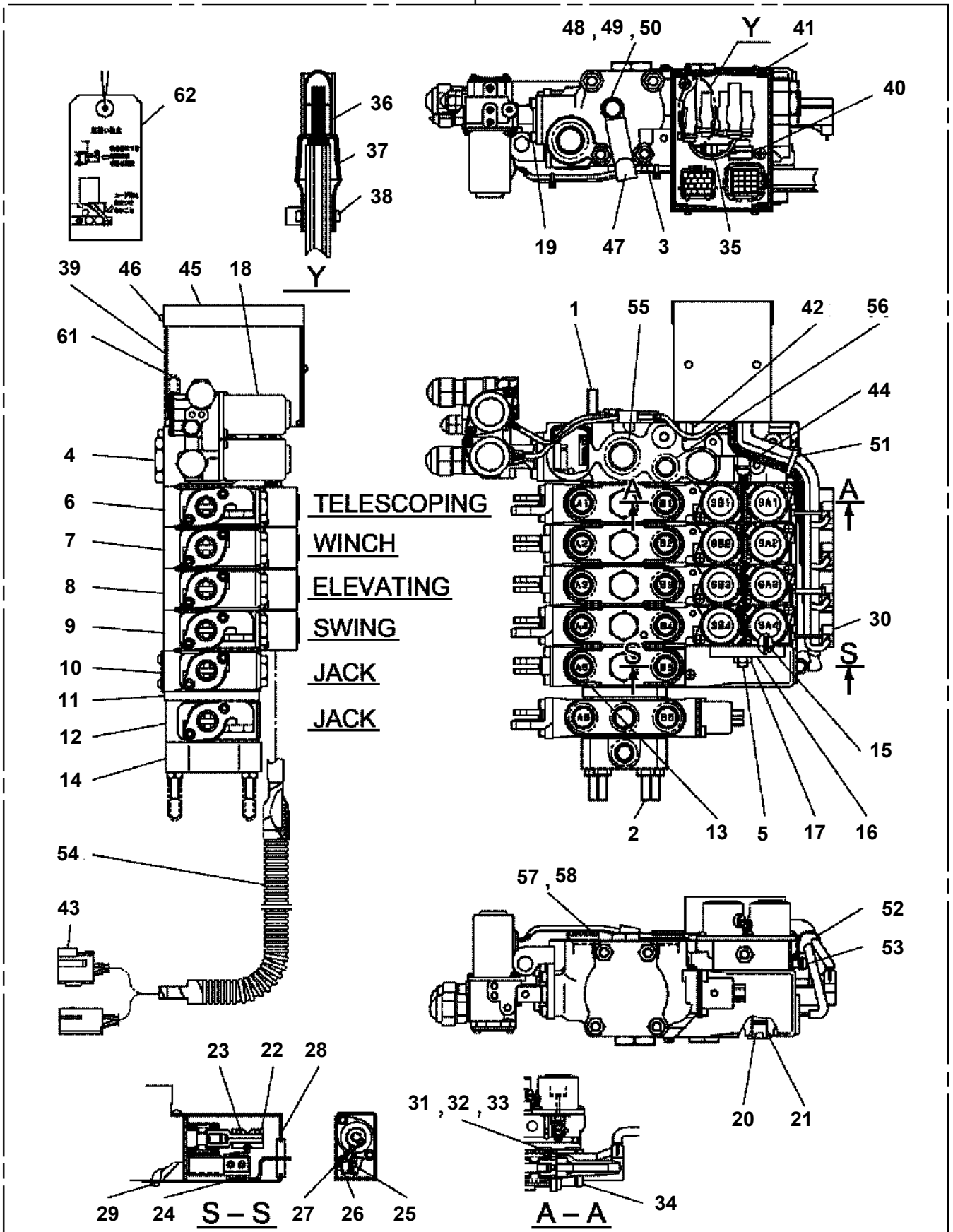

TM-ZF500 31093010120A FRAME/SL,REMOTE-RADIO CONT.

Pos No.	Parts No	Parts Name	Qty	Unit	Technical Data	Serial No (Start)	Serial N
1	36800565050	CASE KIT (UPPER)	1				
2	36800565070	CASE KIT (LOWER)	1				
3	36800555080	LABEL (SEAL)	1				
4	36800095041	BELT ASSY	1				
5	36800565100	COVER (BATTERY)	1				
6	36800095030	CASE (BATTERY)	1				
21	36800095060	CASE (RING)	1				
22	36800565060	ANTENNA (FLEXIBLE)	1				
23	36800565150	PLATE,NAME	1				
24	36801995060	RUBBER ASSY	1				
32	36800565080	CASE ASSY	1				
42	36800295110	GUARD	1				
43	36801995080	GRIP	1				
50	36800562000	SWITCH BOX (RADIO CONTROL.M2.TYPE-B)	1				

TM-ZF500 31093010120A FRAME/SL,REMOTE-RADIO CONT.

Pos No.	Parts No	Parts Name	Qty	Unit	Technical Data	Serial No (Start)	Serial No (End)	Re
7	36802865030	PLATE,NAME	1					
8	36802865050	PLATE,NAME	1					
21	36802865040	CASE (BATTERY)	1					
22	36802865060	BATTERY (4 PIECES)	1					
31	36802865070	STRAP	1					
41	36802865080	RUBBER (FOR SWITCH)	1					
50	36802863000	SWITCH BOX(RADIO CONTROL)	1					

TM-ZF500 31093010120A FRAME/SL,REMOTE-RADIO CONT.
PV1030091-00 SWITCH BOX

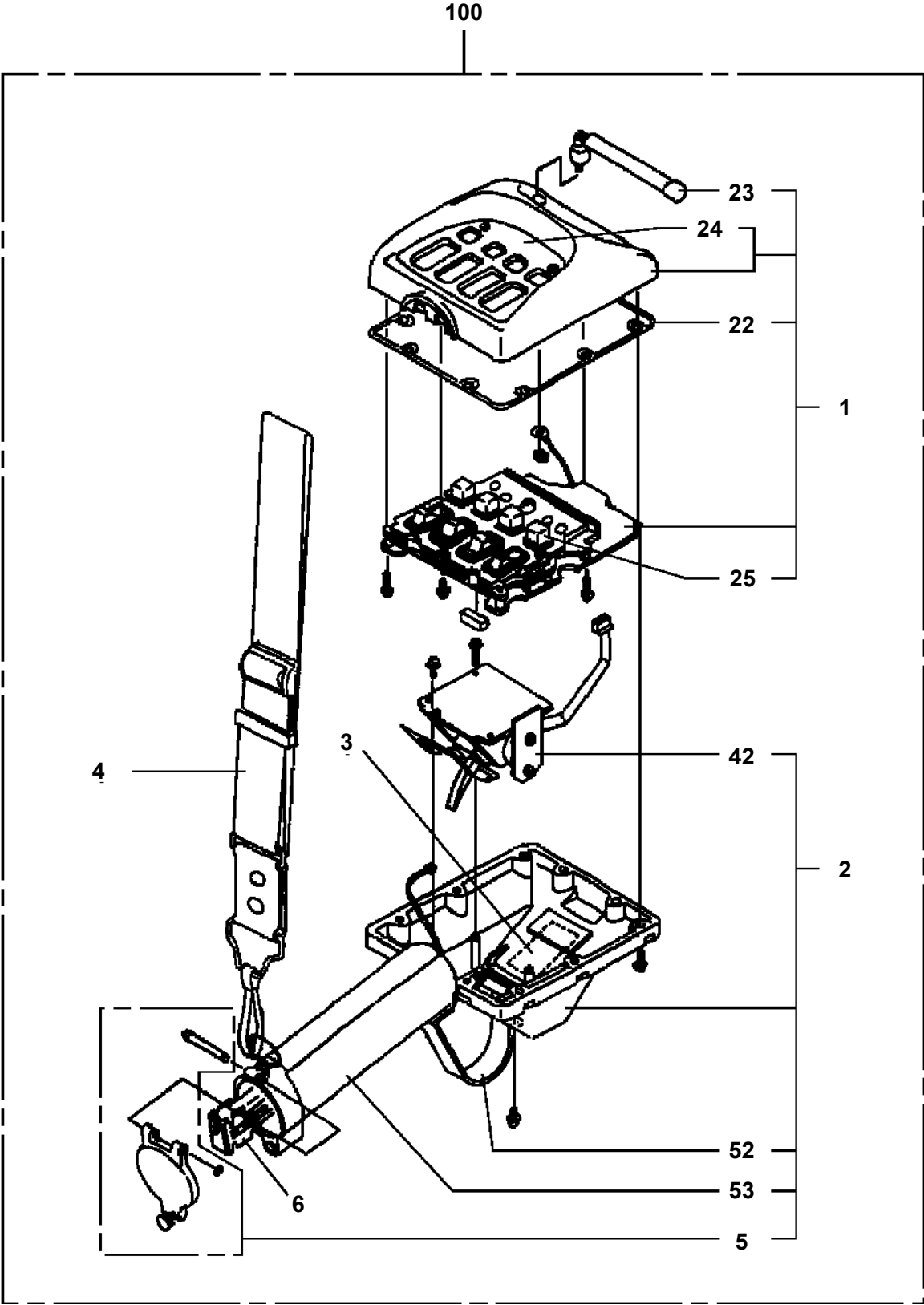

TM-ZF500 31093010120A FRAME/SL,REMOTE-RADIO CONT.
PV1040018-02 CONTROL BOX (RADIO CONTROL.M2.A)

50

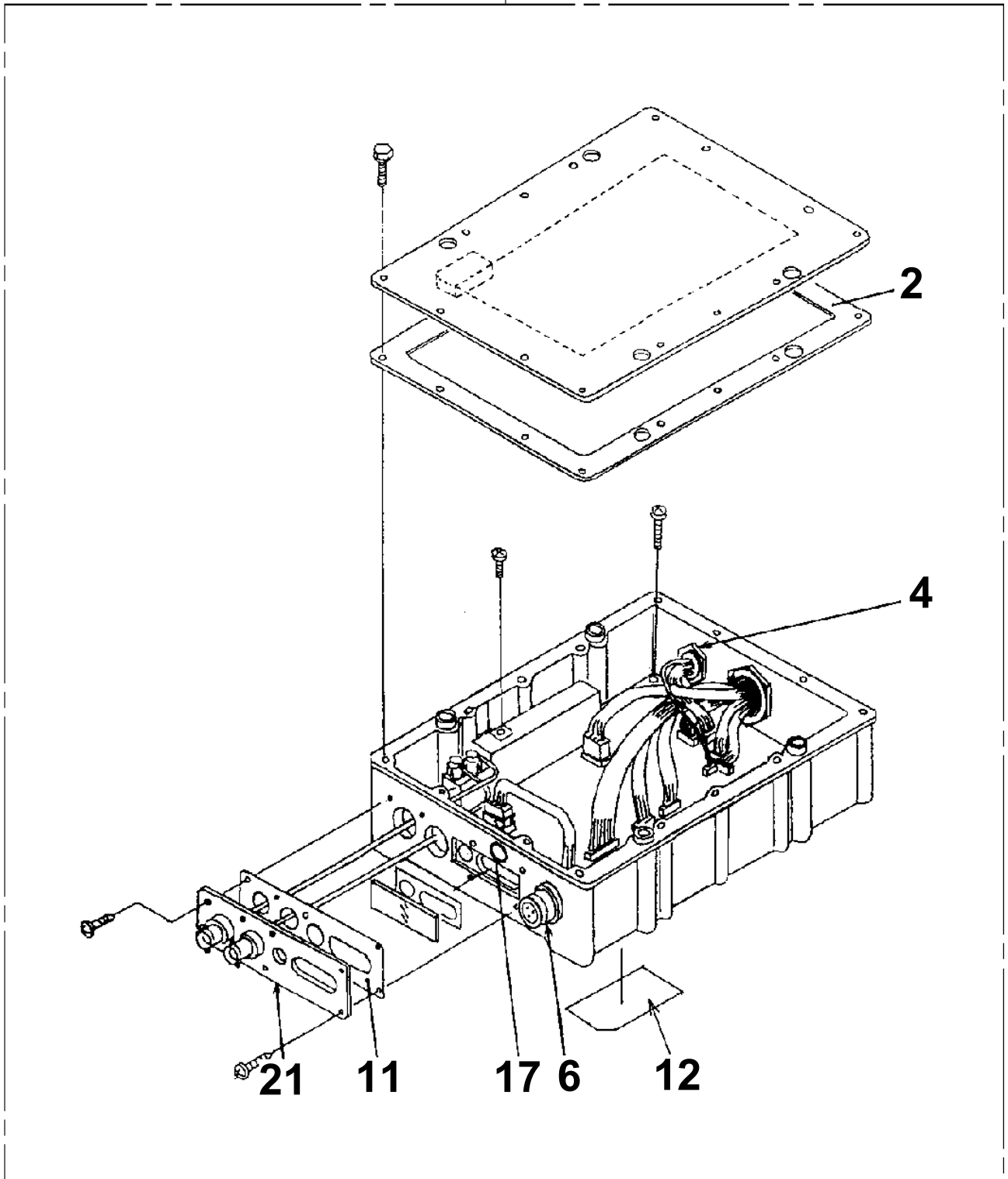

TM-ZF500 31093010120A FRAME/SL,REMOTE-RADIO CONT.
PV1040076-00 CONTROL BOX

100

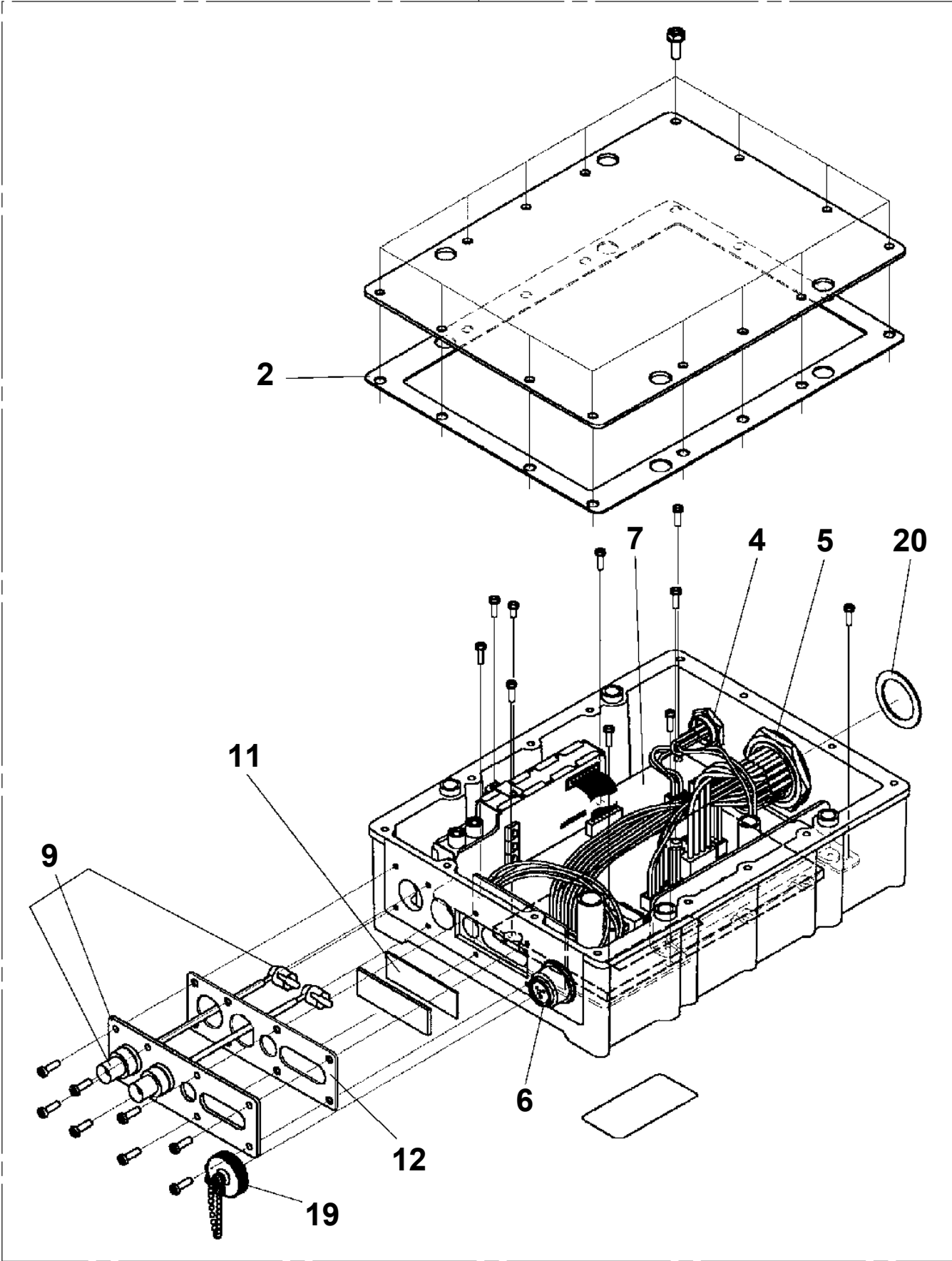

TM-ZF500 31093010120A FRAME/SL,REMOTE-RADIO CONT.
PV1040104-00 CONTROL UNIT

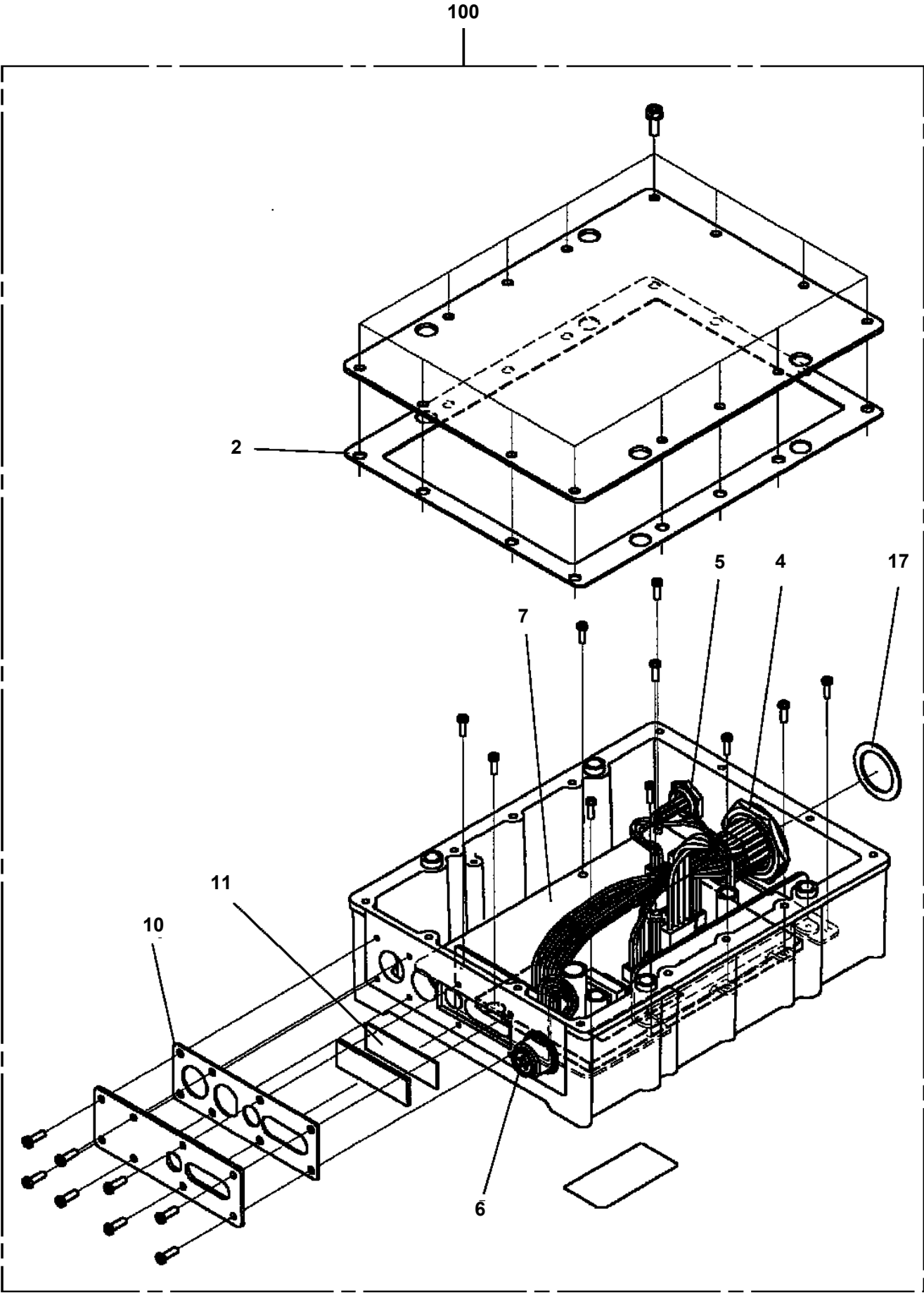

TM-ZF500 31093010120A FRAME/SL,REMOTE-RADIO CONT.
PV1050007-02 CYLINDER,ACCELERATOR

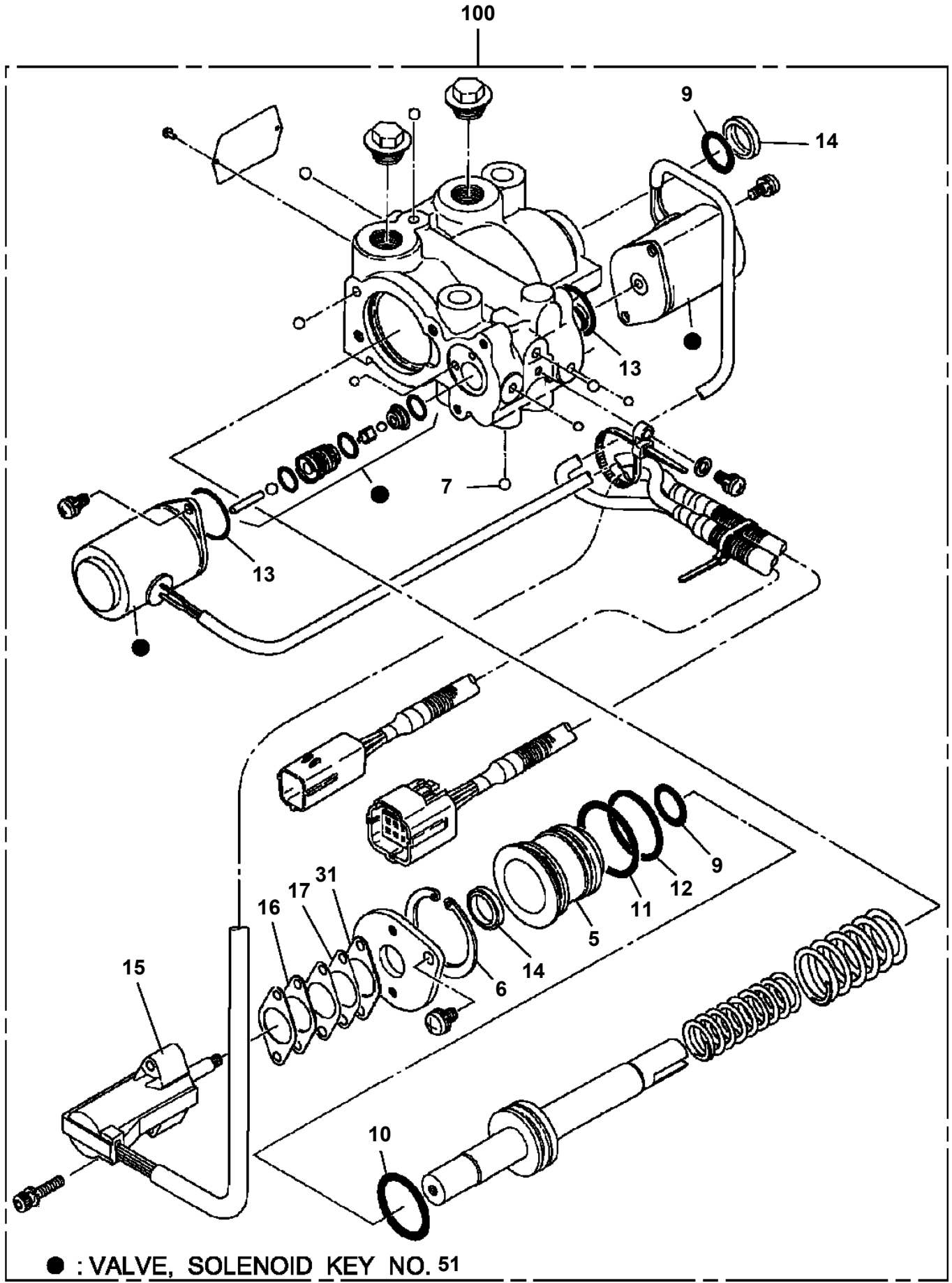

**TM-ZF500 31093010120A FRAME/SL,REMOTE-RADIO CONT.
PV1070398-00 RADIO CONTROL (KIT:MITSUMI)**

指示番号 KEY NO.	ラジオコントロール (キット:ミツミセイ) RADIO CONTROL (KIT:MITSUMI)
1	スイッチボックス SWITCH BOX
2	アンテナ ANTENNA
3	コントロールユニット CONTROL UNIT

TM-ZF500 31093010120A FRAME/SL,REMOTE-RADIO CONT.
 PV1080014-00 PARTS,BML (3,4 SECT.MANUAL)

1	ハイセンASSY ELEC.ASSY
3	デテクタ,オーバ フロント エリア DETECTOR,OVER FRONT AREA
4	インジケータ,アウトリガ INDICATOR,OUTRIGGER
5	デテクタ,ロード DETECTOR,LOAD
6	スイッチ インスタレーション SWITCH INSTALLATION
7	プレートASSY,ネーム PLATE ASSY,NAME
9	デテクタ,ブーム レンクス DETECTOR,BOOM LENGTH
10	モーメント リミッタ MOMENT LIMITER
11	プレートASSY,ネーム PLATE ASSY,NAME

TM-ZF500 31093010120A FRAME/SL,REMOTE-RADIO CONT.
PV1090004-00 PARTS,AWL

1	ハイセンASSY ELEC.ASSY
3	プレートASSY,ネーム PLATE ASSY,NAME
4	ワーキング エリア リミッタ WORKING AREA LIMITER

**TM-ZF500 31093010120A FRAME/SL,REMOTE-RADIO CONT.
PV1250013-00 BOX,STOWING**

10

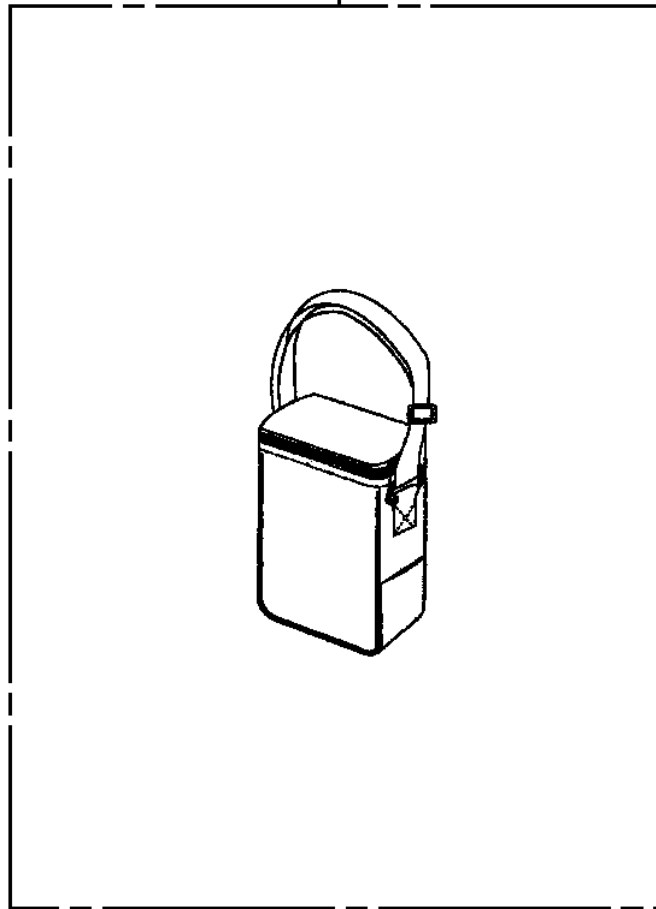

TM-ZF500 31093010120A FRAME/SL,REMOTE-RADIO CONT.
PV1400021-01 ANTENNA (FOR RADIO CONTROL)

10

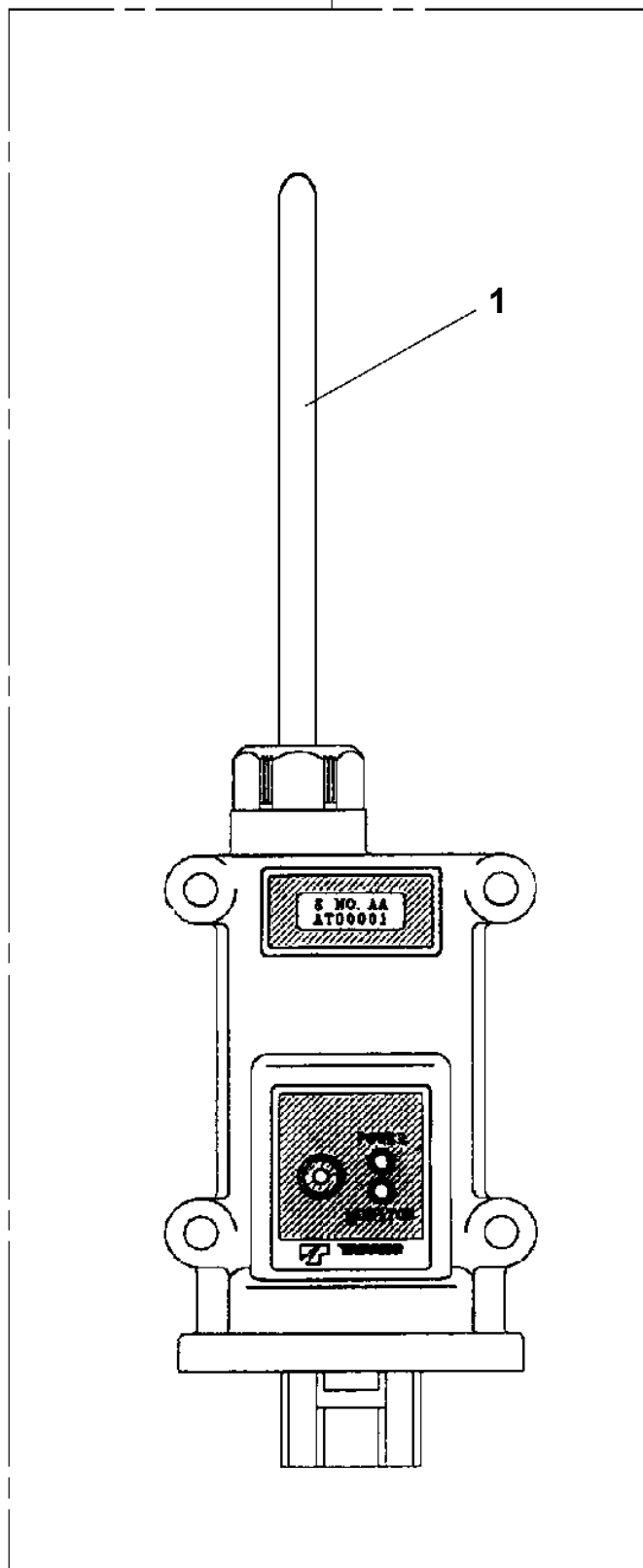

TM-ZF500 31093010120A FRAME/SL,REMOTE-RADIO CONT.
PV1410005-01 MOUNT,ANTENNA (RADIO CONTROL,TYPE-A)

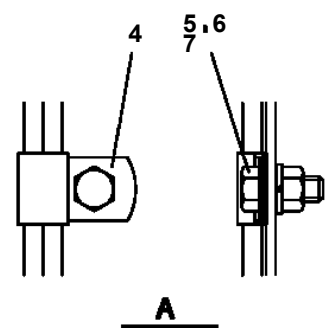
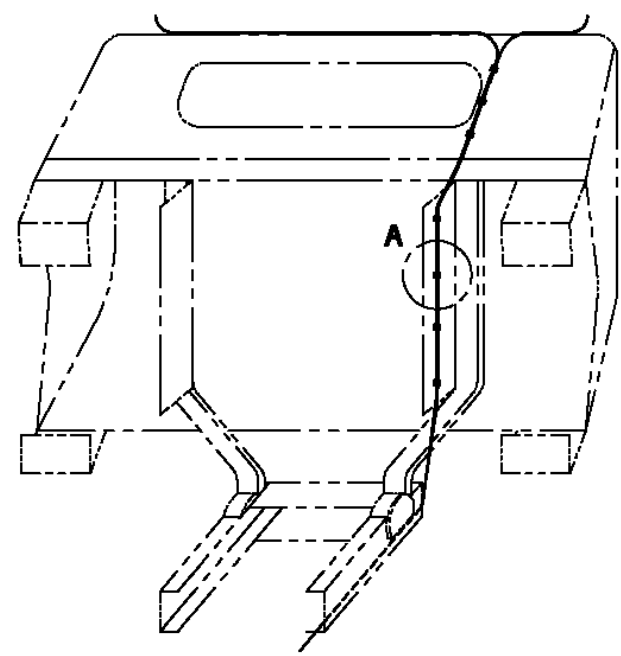
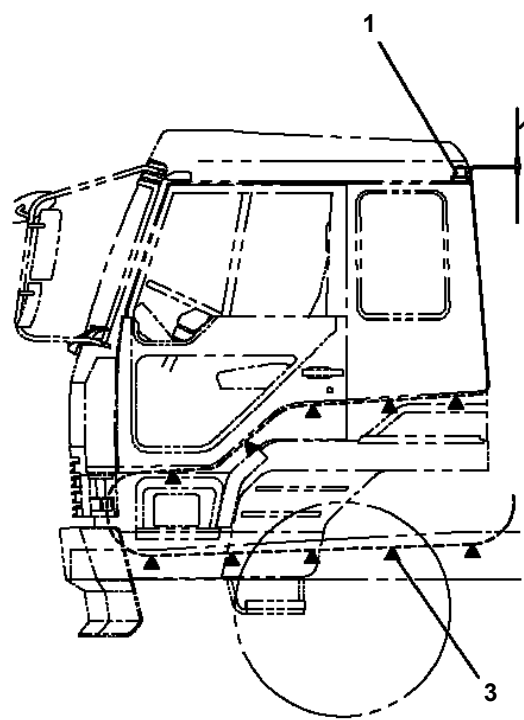
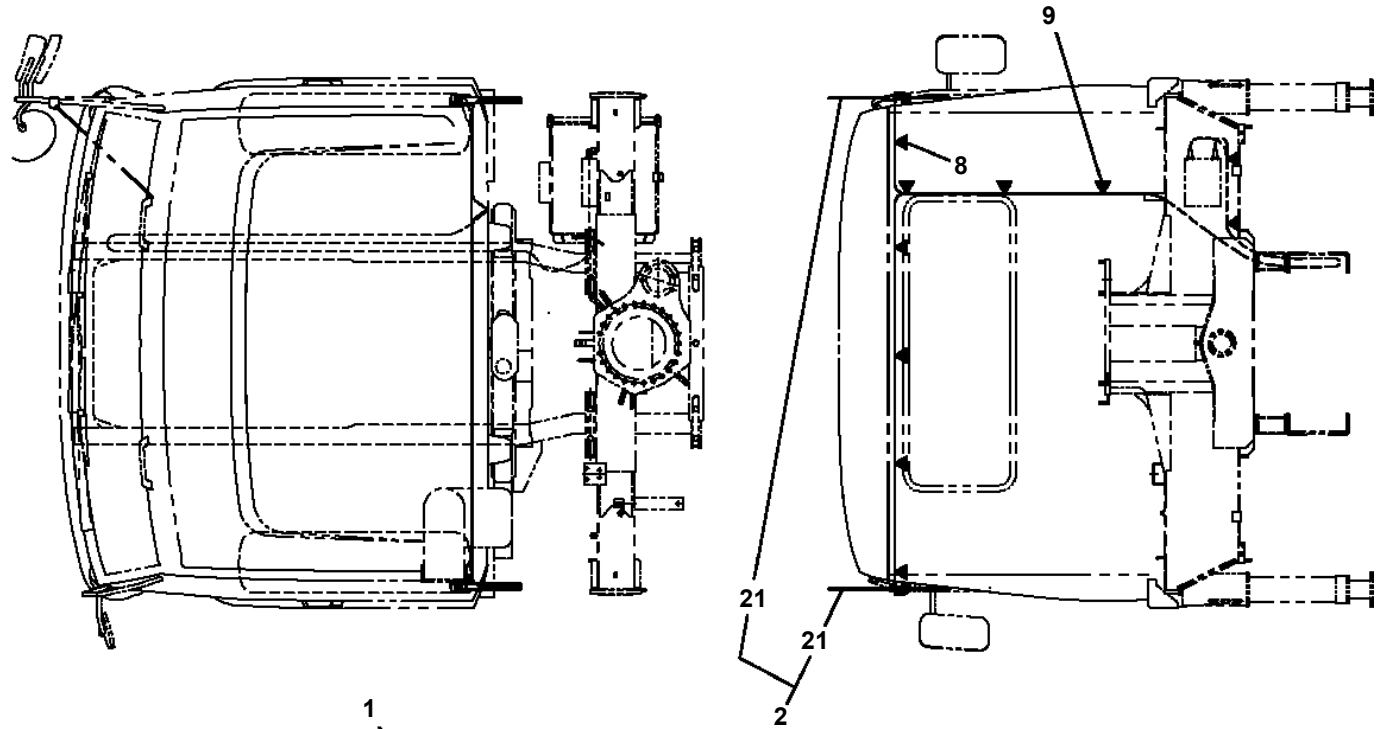

**TM-ZF500 31093010120A FRAME/SL,REMOTE-RADIO CONT.
PX1940184-01 MOUNT (BOOM)**

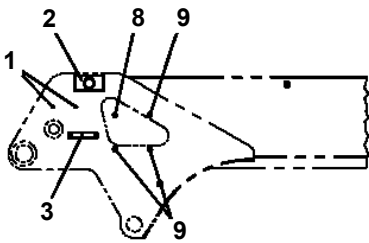
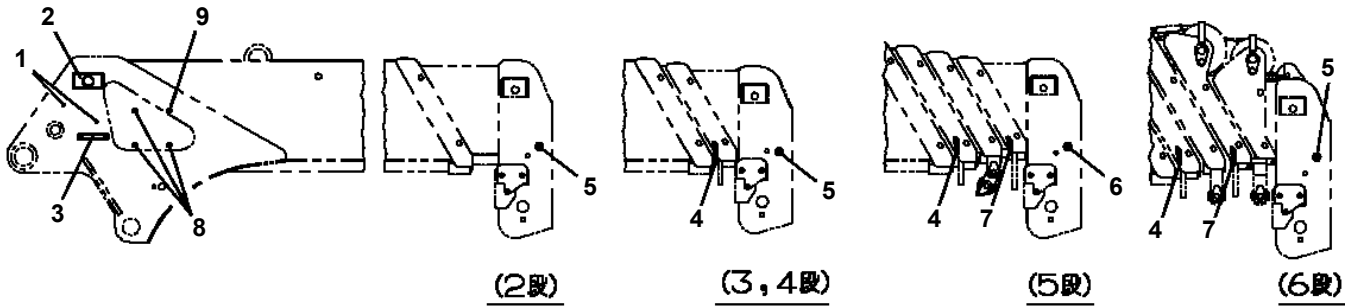

ZR230, 230W, 263Jの場合

ZR505, 555の場合

ZRの場合

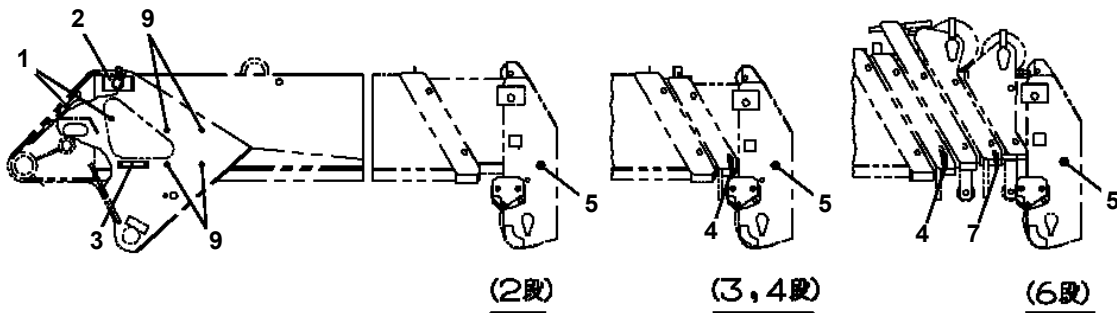

ZF300, 360, 500 (2~6段) の場合

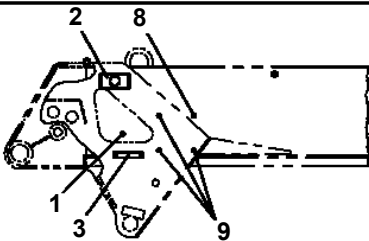

ZF230, 260, 290,
300J (2~4段), 263Jの場合

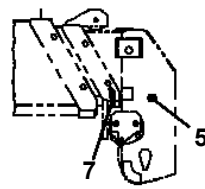

ZF263, 293, 303Jの場合

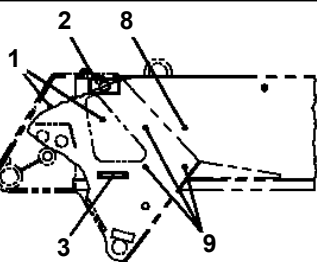

ZF260, 290, 300J (5,6段) の場合

ZFの場合

TM-ZF500 31093010120A FRAME/SL,REMOTE-RADIO CONT.
PY1300037-00 COOLER,OIL

指示番号 KEY NO.	クーラ,オイル COOLER,OIL
1	オイル クーラ インスタレーション OIL COOLER INSTALLATION
2	パイピング,クーラ PIPING,COOLER
3	ハイセンASSY ELEC.ASSY

TM-ZF500 31093010120A FRAME/SL,REMOTE-RADIO CONT.
PY1560027-01 ALARM SYSTEM

指示番号 KEY NO.	アラーム システム (キフクカクノウスレ: SWツキPTOケーブル ルタイオウ) ALARM SYSTEM
1	ハイセンASSY (クレーンホンタイプ) ELEC. ASSY (CRANE)
2	ハイセンASSY (カソウシャリヨウブ) ELEC. ASSY (CARRIER)
4	プレート ASSY, ネーム PLATE ASSY, NAME

CLICK HERE TO **DOWNLOAD** THE COMPLETE MANUAL

- Thank you very much for reading the preview of the manual.
- You can download the complete manual from: www.heydownloads.com by clicking the link below



- Please note: If there is no response to CLICKING the link, please download this PDF first and then click on it.

CLICK HERE TO **DOWNLOAD** THE COMPLETE MANUAL