

**OC-33W-1-20500 LOWER,MITSUBISHI PA-FE73DC 6K3**

PB3000224-00 POWER UNIT  
PO1000154-00 INDICATION PLATES  
PX2000790-01 CARRIER UNIT  
PX3000468-01 MOUNTING UNIT  
PY2000174-01 OPTIONS (LOWER)  
ASSEMBLY

CLICK HERE TO **DOWNLOAD** THE COMPLETE MANUAL

- Thank you very much for reading the preview of the manual.
- You can download the complete manual from: [www.heydownloads.com](http://www.heydownloads.com) by clicking the link below



- Please note: If there is no response to CLICKING the link, please download this PDF first and then click on it.

CLICK HERE TO **DOWNLOAD** THE COMPLETE MANUAL

OC-33W-1-20500 LOWER, MITSUBISHI PA-FE73DC 6K3  
PY2000174-01 OPTIONS (LOWER)

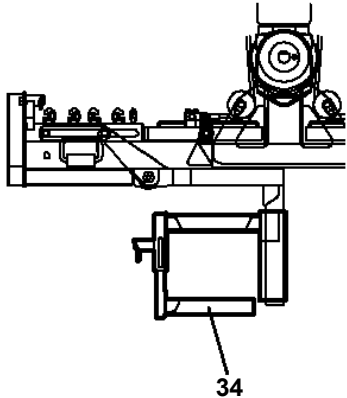
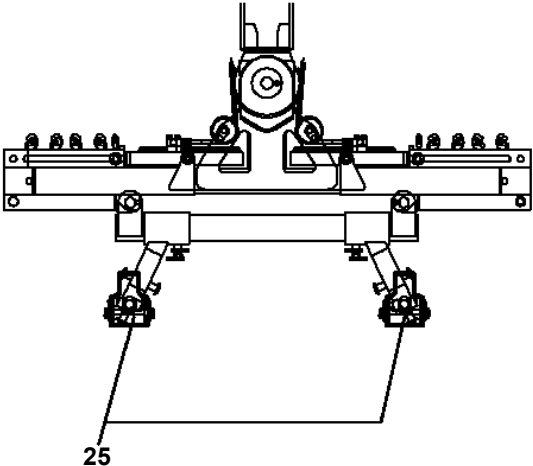
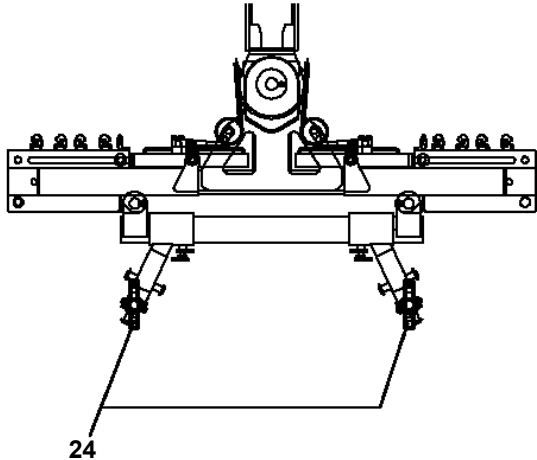
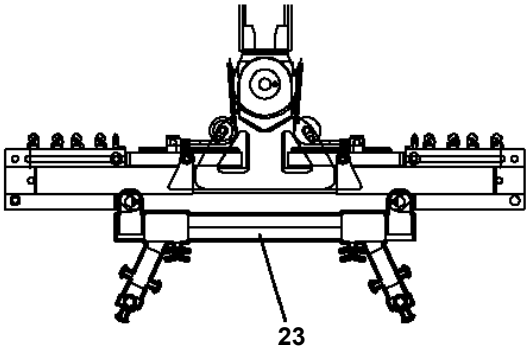
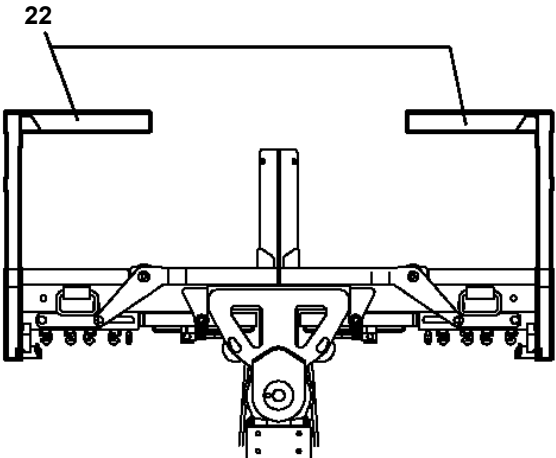
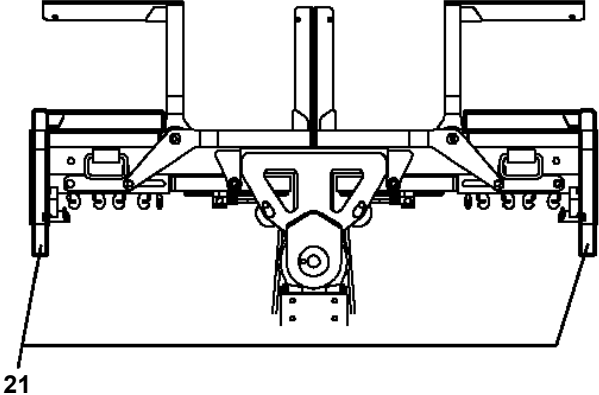

# OC-33W-1-20500 LOWER, MITSUBISHI PA-FE73DC 6K3

Pos No.	Parts No	Parts Name	Qty	Unit	Technical Data	Serial No (Start)	Serial No (End)	Remarks	Pages
1	36102520000	TANK,OIL	1						000009
2	90201201000	NUT	2		M10				
3	31660550100	BAND	1						
4	31660550200	CUSHION	1						

**OC-33W-1-20500 LOWER, MITSUBISHI PA-FE73DC 6K3  
PI1300026-01 FILTER, OIL (WAKO)**

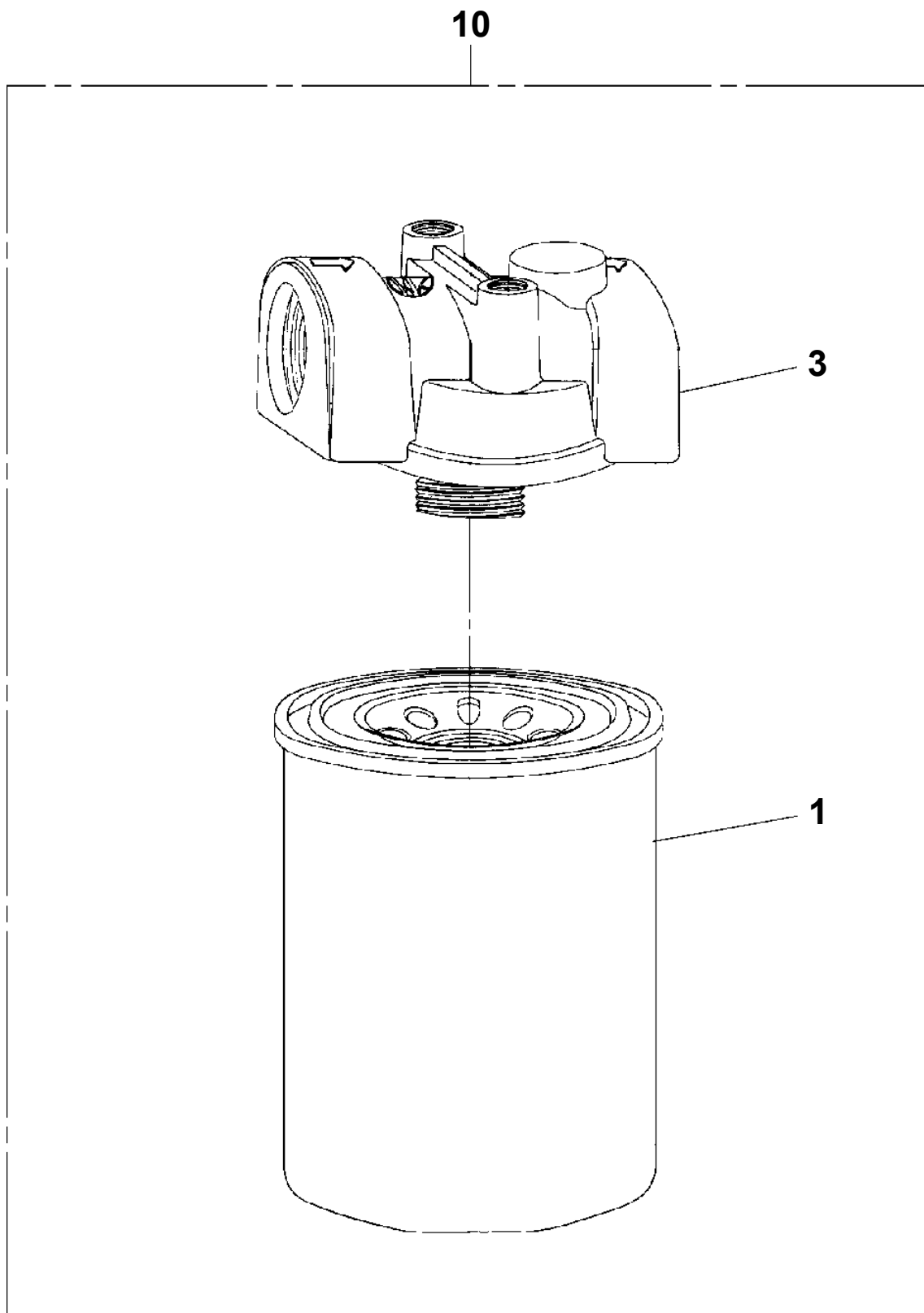

## OC-33W-1-20500 LOWER,MITSUBISHI PA-FE73DC 6K3

Pos No.	Parts No	Parts Name	Qty	Unit	Technical Data	Serial No (Start)	Serial No (End)	P
2	32691127730	SUPPORT	1					
3	32691127740	SUPPORT	1					
4	32691127750	GUIDE (RAIL)	2					
5	32691127760	RUBBER	1					
6	32691127770	RAIL (SLIDE)	2					
7	32691127780	LATCH	1					
8	42691707600	BOLT (WITH WASHER)	4		M10X22			
9	32690987750	BOLT (WITH W,SW)	4		M4X12			
10	32690987770	SCREW,MACHINE	32		M4X8			
11	32691127790	SCREW,MACHINE (WITH SW,NUT)	4		M4X16			
100	32691127630	DECK (DRAWER ASSY)	1					

## OC-33W-1-20500 LOWER,MITSUBISHI PA-FE73DC 6K3

Pos No.	Parts No	Parts Name	Qty	Unit	Technical Data	Serial No (Start)	Serial No (End)	Remark
1	37001706350	CABLE,CONTROL (U-SHIN)	1		L=1300			
	37001706280	CABLE,CONTROL (WAKEN)	1		L=1300			
2	32711220100	SUPPORT	1					
3	90102208035	BOLT	1		M8X35			
4	90201200800	NUT	3		M8			
5	90302040801	WASHER,SPRING	7		8			
6	90101208065	BOLT	2		M8X65			
7	90101208016	BOLT	3		M8X16			
8	37000311490	SPACER	1		L=20			
9	31323144300	LINK	1					
10	31322224200	PLATE	1		L=1			
11	90303071201	WASHER,PLAIN	1		12			
12	80136840020	PIN,SPLIT	1		4X20			
13	82100002004	CLAMP	2		WR8			
14	90101206016	BOLT	2		M6X16			
15	90201200600	NUT	2		M6			
16	90302040601	WASHER,SPRING	2		6			
17	32711220010	HARNESS	1					
18	32711590100	SUPPORT	1					
19	90101208025	BOLT	2		M8X25			
20	91810130240	FASTENER	10					
21	31710230200	PIN	1					
22	80136325014	PIN,SPLIT	1		2.5X14			
23	90303070601	WASHER,PLAIN	2		6			
24	32711460300	SUPPORT	1					

CLICK HERE TO **DOWNLOAD** THE COMPLETE MANUAL

- Thank you very much for reading the preview of the manual.
- You can download the complete manual from: [www.heydownloads.com](http://www.heydownloads.com) by clicking the link below



- Please note: If there is no response to CLICKING the link, please download this PDF first and then click on it.

CLICK HERE TO **DOWNLOAD** THE COMPLETE MANUAL

OC-33W-1-20500 LOWER, MITSUBISHI PA-FE73DC 6K3  
 PO1014768-00 PLATE ASSY, NAME (LOWER)

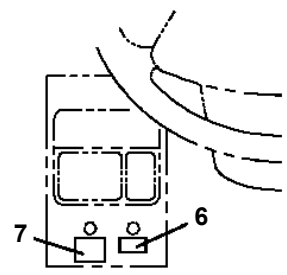
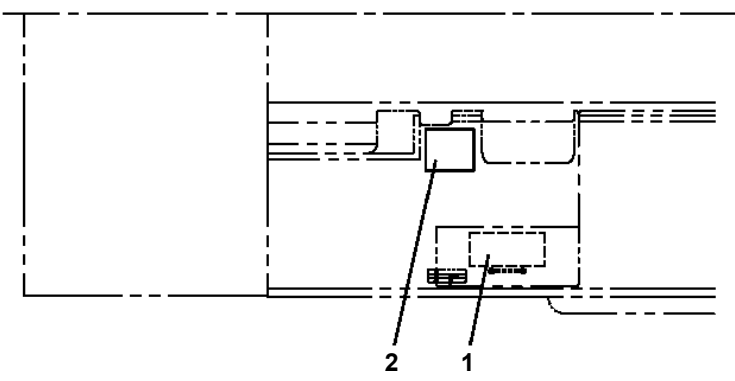
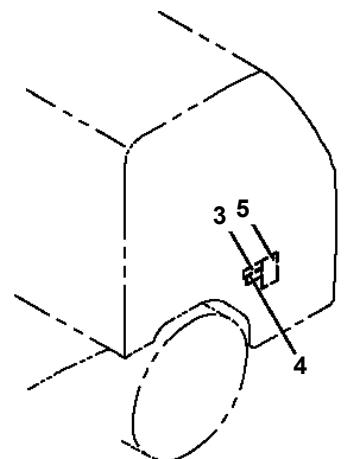
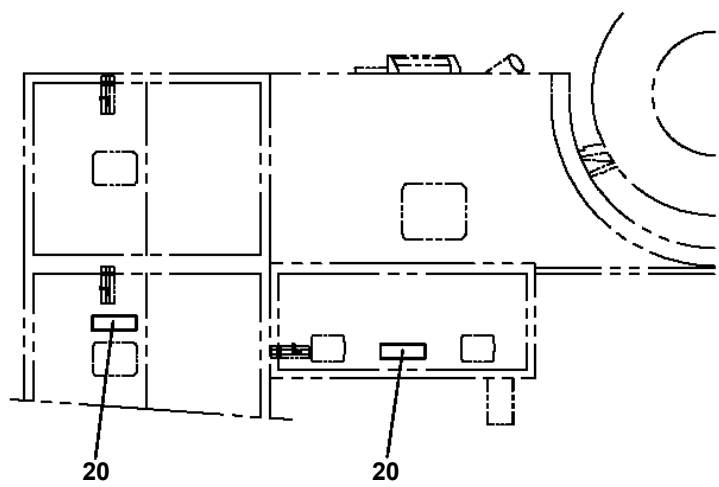

キャブ内フロントパネルハンドル左下

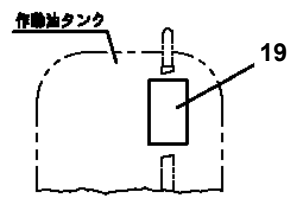
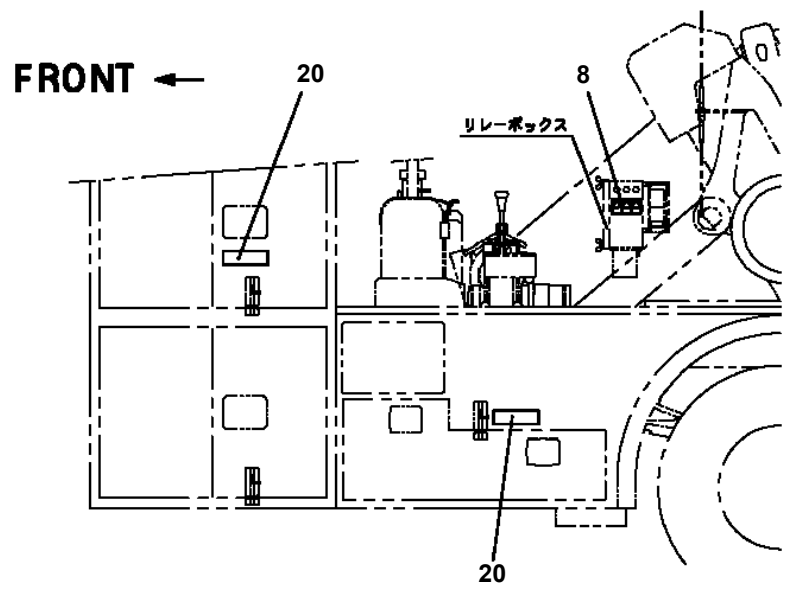

補助用敷金シール  
 10, 11, 12  
 13, 14, 15  
 16, 17, 18

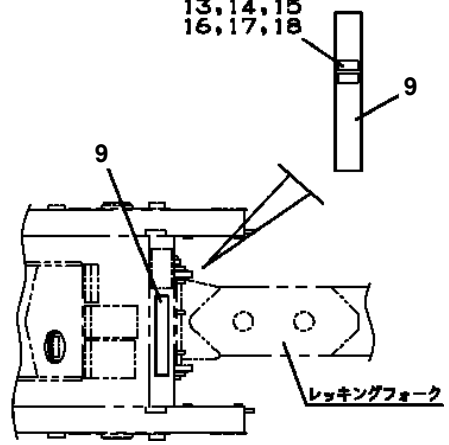

**OC-33W-1-20500 LOWER, MITSUBISHI PA-FE73DC 6K3  
PW1010296-00 ACCESSORIES (SUPPORT/SPRING HANGER, OP.)**

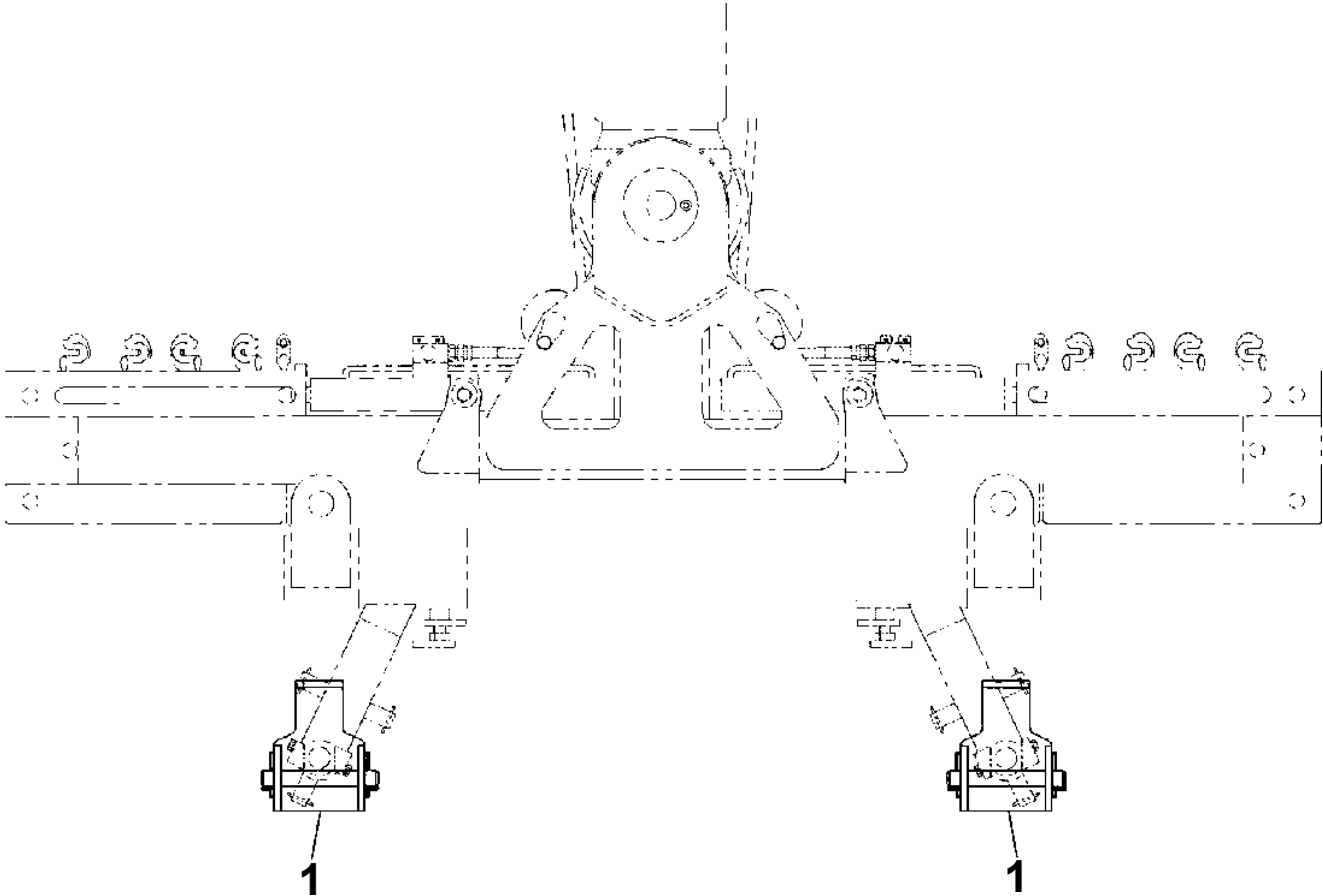

**1**

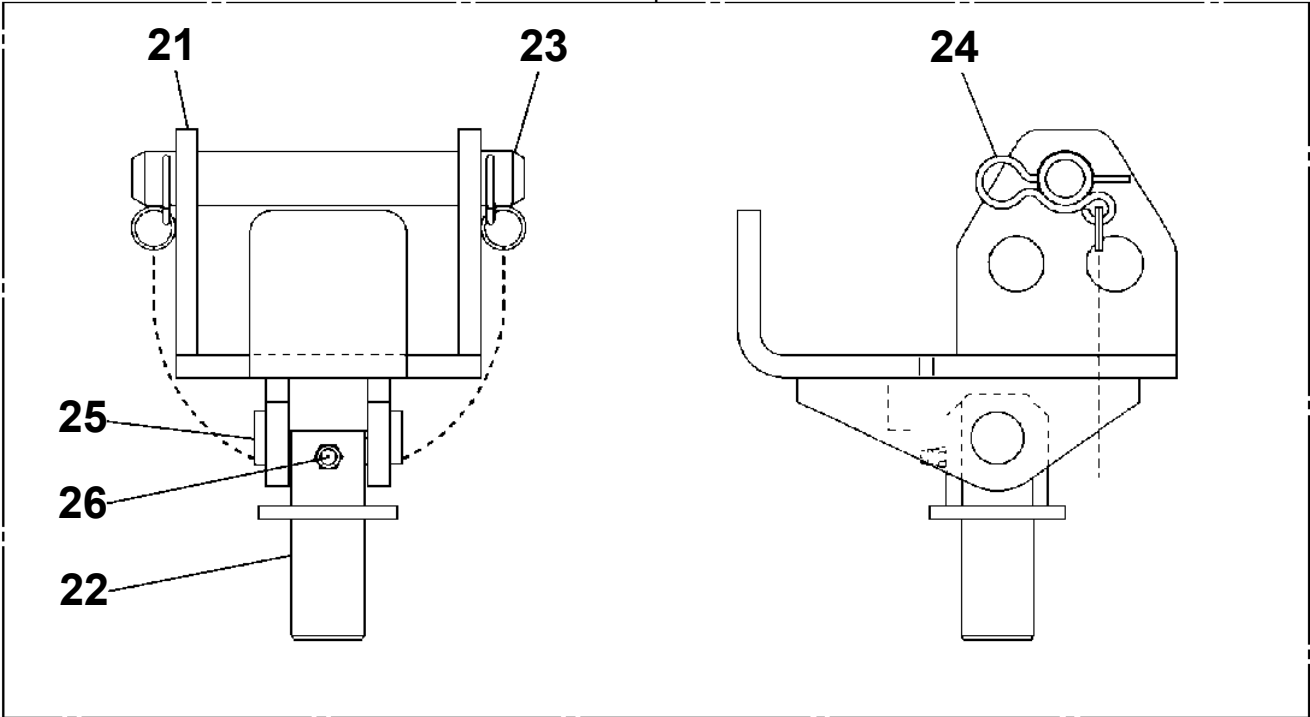

**OC-33W-1-20500 LOWER, MITSUBISHI PA-FE73DC 6K3  
PW1010355-00 ACCESSORIES (BELT/TIRE L-SIZE)**

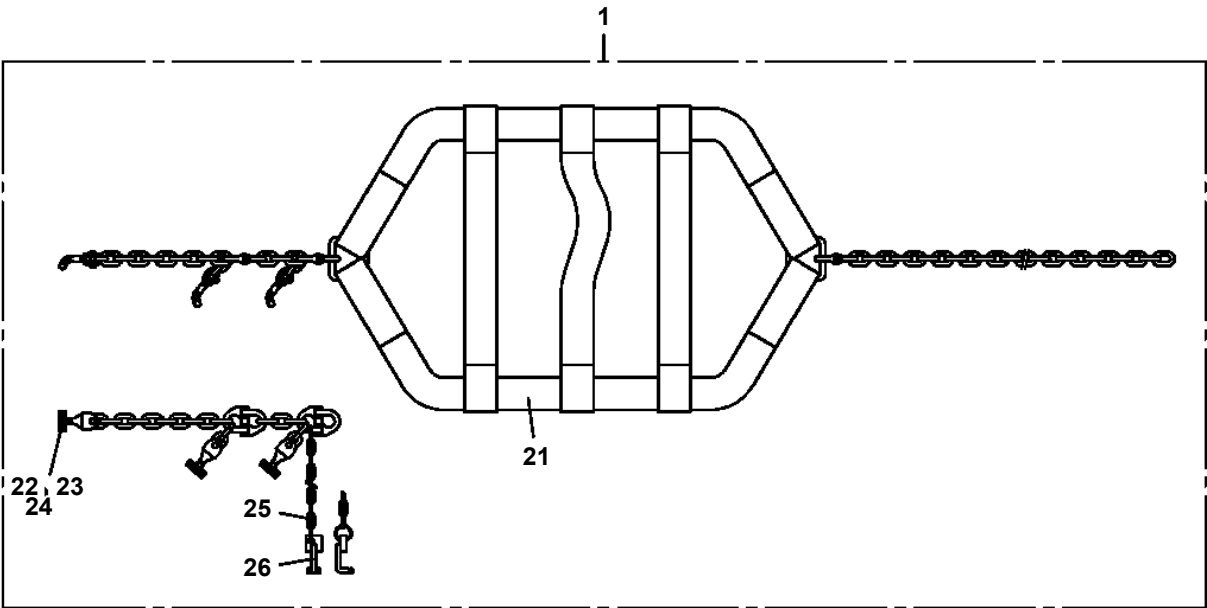
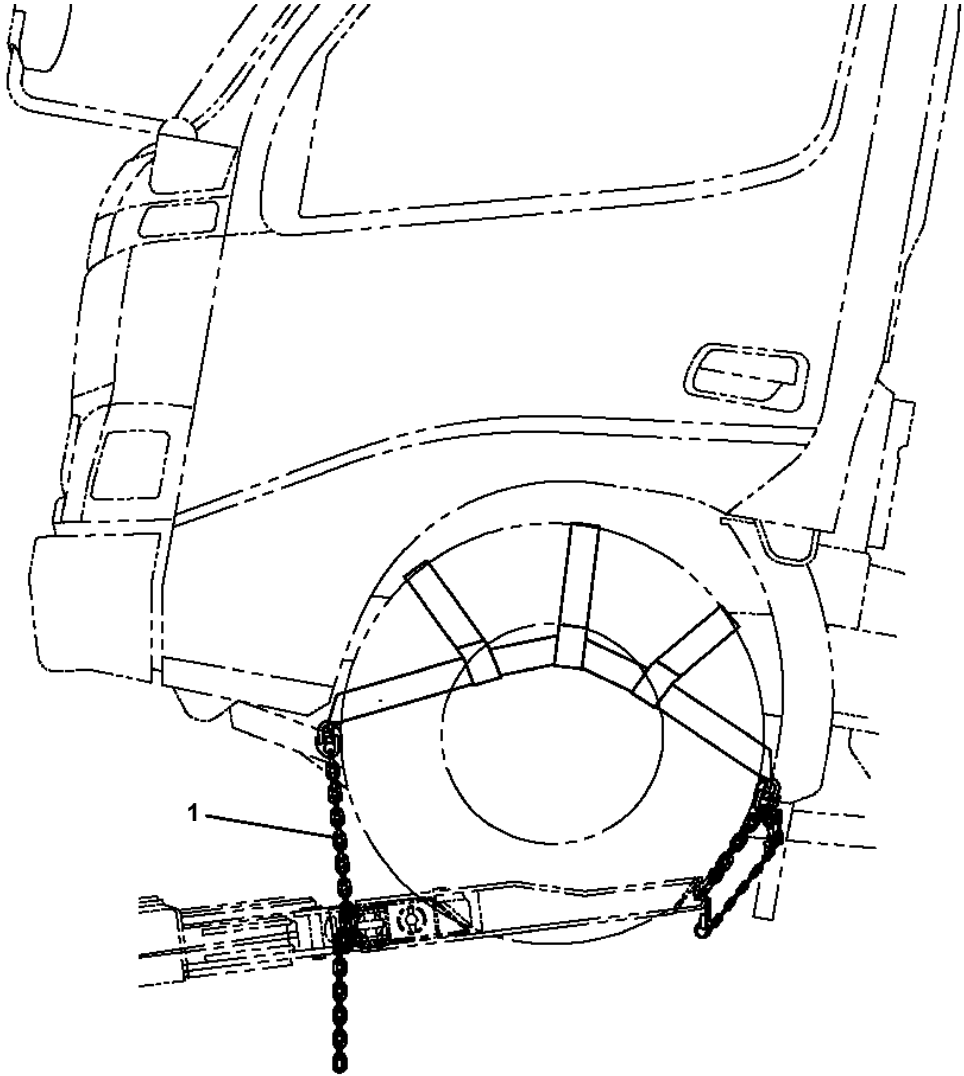

# OC-33W-1-20500 LOWER, MITSUBISHI PA-FE73DC 6K3

Pos No.	Parts No	Parts Name	Qty	Unit	Technical Data	Serial No (Start)	Serial No (End)	Remarks	Pages
1	32880240100	SUPPORT	1						
2	82400000095	GROMMET	1						

OC-33W-1-20500 LOWER, MITSUBISHI PA-FE73DC 6K3  
PX1350748-00 BOX, TOOL

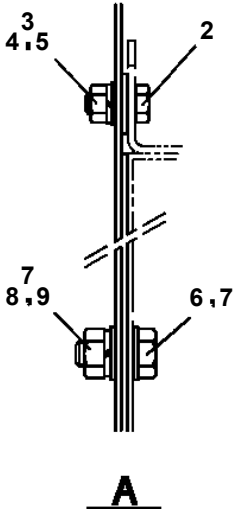
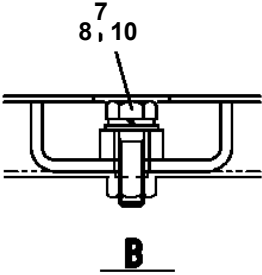
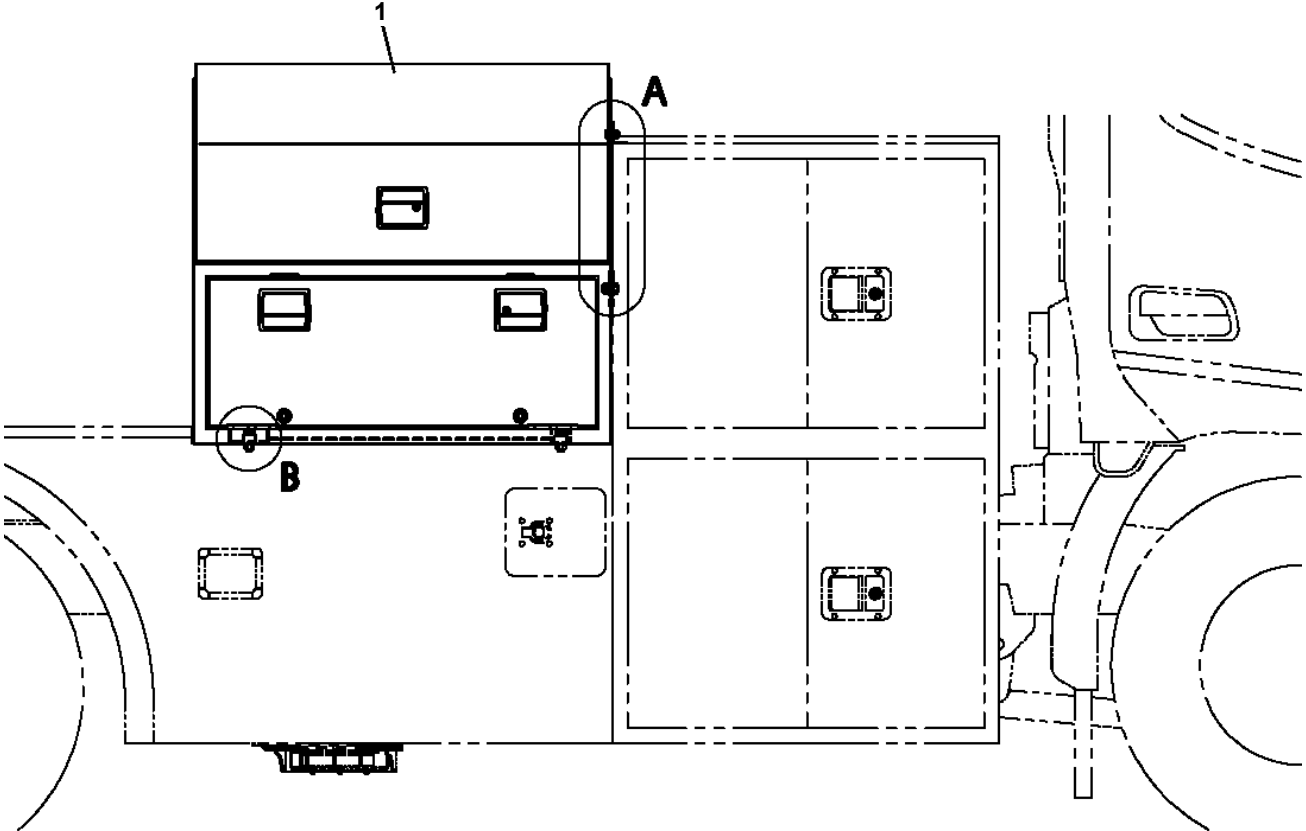

OC-33W-1-20500 LOWER, MITSUBISHI PA-FE73DC 6K3  
PX1350936-00 BOX, TOOL

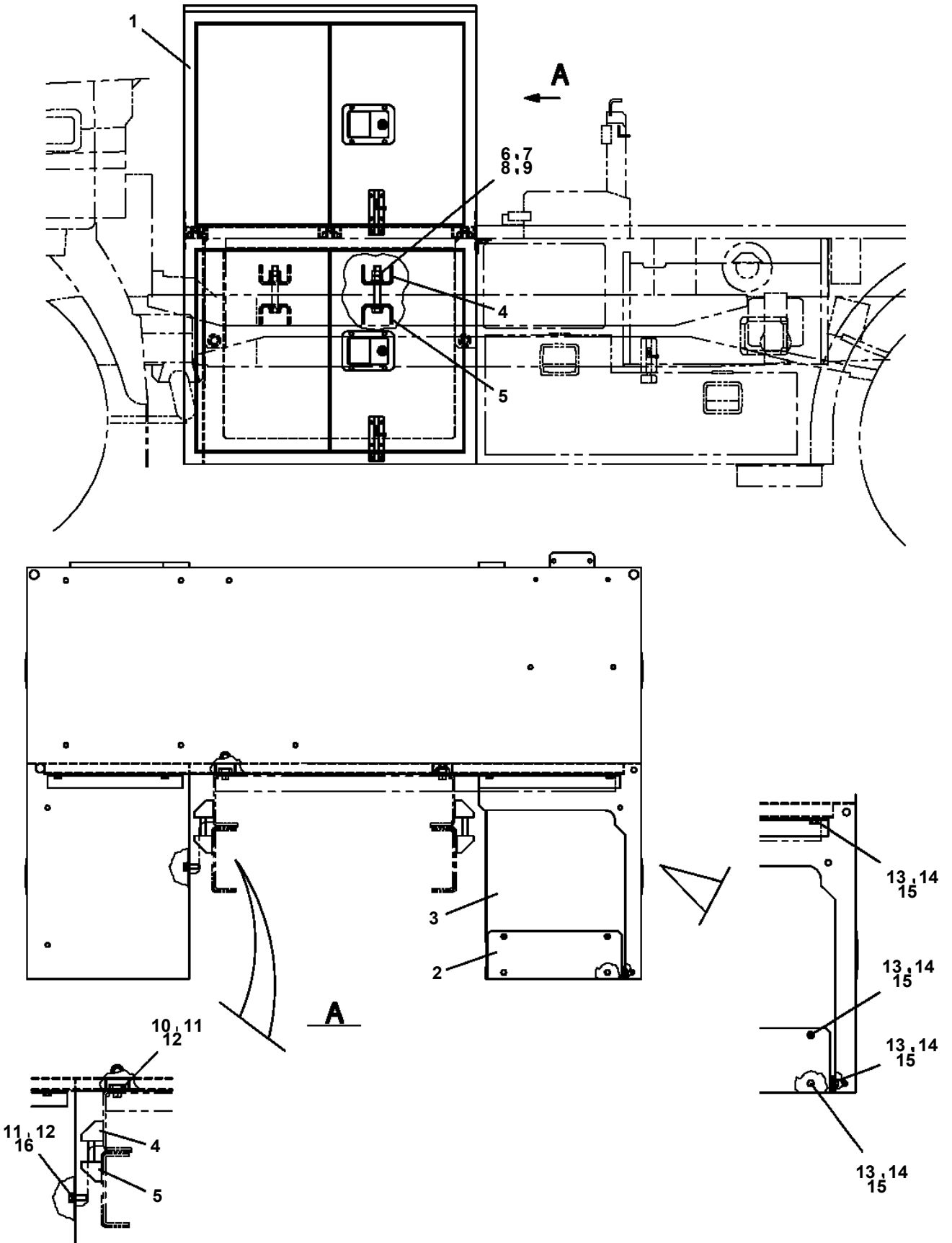

CLICK HERE TO **DOWNLOAD** THE COMPLETE MANUAL

- Thank you very much for reading the preview of the manual.
- You can download the complete manual from: [www.heydownloads.com](http://www.heydownloads.com) by clicking the link below



- Please note: If there is no response to CLICKING the link, please download this PDF first and then click on it.

CLICK HERE TO **DOWNLOAD** THE COMPLETE MANUAL