

Parts Catalog

Parts Catalog

パーツカタログ

オールテレーンクレーン
オプション & 追加部品

ATF130G-5

型式記号：ATF-130G5(J)-1
適用製造番号：GC5117 ~

パーツカタログ

ATF-130G5(J)-1_P1-2EJ

02

CLICK HERE TO **DOWNLOAD** THE COMPLETE MANUAL

- Thank you very much for reading the preview of the manual.
- You can download the complete manual from: www.heydownloads.com by clicking the link below



- Please note: If there is no response to CLICKING the link, please download this PDF first and then click on it.

CLICK HERE TO **DOWNLOAD** THE COMPLETE MANUAL

| | | | | | |
|--|--|---------------|--|----|--|
| システム名称 フレーム(ジ' ヨウフ' ソウチカンレン) System Name FRAME (FOR SUPERSTRUCTURE) | | PK100-0823-00 | | | |
| 1 | | 2 | | 3 | |
| 4 | | 5 | | 6 | |
| 7 | | 9 | | 11 | |
| 12 | | 14 | | 15 | |
| 適用製造番号によっては取り付けがないものもあります。 MACHINES OF SOME SERIAL NO. ARE NOT EQUIPPED WITH THESE PARTS. | | | | | |

| システム名称 フレーム(ジ' ヨウフ' ソウチカンレン) System Name FRAME (FOR SUPERSTRUCTURE) | | PK100-0823-00 | | | | | | | | | | | | |
|--|--|---------------|--|---------------|-----------------|-------------|---|--|----|---|--|----|----|--|
| 21 | | 22 | | 24 | | | | | | | | | | |
| 25 | | 26 | 上層キャブ 右側スイッチパネル キャリヤキャブ 前面パネル | 28 | | | | | | | | | | |
| 30 | | 31 | | 32 | | | | | | | | | | |
| 33 | 引出シリンダロッド クレーンキャブ下部ステップ | 34 | 341 st DASSY (DUI-FI-FI-CR) MODIFICATION ASSY (TELEMATICS) <table border="1" style="width:100%; border-collapse: collapse; margin-top: 10px;"> <thead> <tr> <th>図番 KEY NO.</th> <th>部名 PART NAME</th> <th>注 REMARK</th> </tr> </thead> <tbody> <tr> <td style="text-align: center;">1</td> <td>341st DASSY MODIFICATION ASSY</td> <td style="text-align: center;">上層</td> </tr> <tr> <td style="text-align: center;">2</td> <td>341st DASSY MODIFICATION ASSY</td> <td style="text-align: center;">下層</td> </tr> </tbody> </table> | 図番 KEY NO. | 部名 PART NAME | 注 REMARK | 1 | 341 st DASSY MODIFICATION ASSY | 上層 | 2 | 341 st DASSY MODIFICATION ASSY | 下層 | 36 | |
| 図番 KEY NO. | 部名 PART NAME | 注 REMARK | | | | | | | | | | | | |
| 1 | 341 st DASSY MODIFICATION ASSY | 上層 | | | | | | | | | | | | |
| 2 | 341 st DASSY MODIFICATION ASSY | 下層 | | | | | | | | | | | | |
| 適用製造番号によっては取り付けがないものもあります。 MACHINES OF SOME SERIAL NO. ARE NOT EQUIPPED WITH THESE PARTS. | | | | | | | | | | | | | | |

| 組立名称 Assembly Name | | バルブソレノイド VALVE, SOLENOID | | FIG. P1112-0196-01 | | | | | | | | | | | | | | | |
|-----------------------------|------------------|---|---------------------|--------------------|---|---|---|---|---|---|---|---|---|---|---|----------------|----------------------------|-------------|---|
| スペック番号 Specification No. | | A < ATF-130G-1-90101 > B < ATF-130G-1-90102 > | | | | | | | | | | | | | | | | | |
| 指示番号 Key No. | 部品番号 Part No. | 部品名称 Part Name | Q'ty Per Section 個数 | | | | | | | | | | | | | 実施号機 (変更番号) | Serial No. Modifi. No.) | ページ Page | |
| | | | A | B | C | D | E | F | G | H | I | J | K | L | M | | | | N |
| 52 | 366-416-87510 | PLUG | - | 1 | | | | | | | | | | | | | | | |
| 54 | 366-416-87520 | RETAINER (A) | - | 2 | | | | | | | | | | | | | | | |
| 55 | 366-416-87530 | RETAINER (B) | - | 2 | | | | | | | | | | | | | | | |
| 56 | 366-416-87540 | RETAINER (C) | - | 1 | | | | | | | | | | | | | | | |
| 57 | 366-401-75040 | SPACER | - | 4 | | | | | | | | | | | | | | | |
| 58 | 366-416-87550 | SPRING (A) | - | 1 | | | | | | | | | | | | | | | |
| 59 | 366-416-87560 | SPRING (C) | - | 1 | | | | | | | | | | | | | | | |
| 60 | 366-429-15020 | NUT | - | 1 | | | | | | | | | | | | | | | |
| 61 | 366-416-87570 | ROD | - | 1 | | | | | | | | | | | | | | | |
| 62 | 366-416-87580 | GUIDE (SOLENOID) | - | 1 | | | | | | | | | | | | | | | |
| 63 | 366-463-75050 | COIL, SOLENOID | - | 1 | | | | | | | | | | | | | | | |
| 65 | 366-463-75030 | SCREW | - | 2 | | | | | | | | | | | | | | | |
| 66 | 910-005-01200 | O-RING <ASS68-012> | - | 4 | | | | | | | | | | | | | | | |
| 67 | 910-011-02000 | O-RING <1A P20> | - | 1 | | | | | | | | | | | | | | | |
| 68 | 910-028-01800 | O-RING <1B P18> | - | 2 | | | | | | | | | | | | | | | |
| 69 | 910-010-02500 | O-RING <S25> | - | 1 | | | | | | | | | | | | | | | |
| 92 | 901-319-05045 | BOLT, HEXAGON SOCKET <M5X45> | - | 4 | | | | | | | | | | | | | | | |
| 100 | 366-463-80001 | VALVE, SOLENOID | - | 1 | | | | | | | | | | | | | | | |

MEMO

| 組立名称 Assembly Name | | ジブASSY (マウント) JIB ASSY (MOUNT) | | FIG. PJ505-0052-00 | | | | | | | | | | | | | | |
|-----------------------------|------------------|---|---------------------|--------------------|---|---|---|---|---|---|---|---|---|---|---|----------------|----------------------------|-------------|
| スペック番号 Specification No. | | A < ATF-130G-1-90101 > B < ATF-130G-1-90102 > | | | | | | | | | | | | | | | | |
| 指示番号 Key No. | 部品番号 Part No. | 部品名称 Part Name | Q'ty Per Section 個数 | | | | | | | | | | | | | 実施号機 (変更番号) | Serial No. Modifi. No.) | ページ Page |
| | | | A | B | C | D | E | F | G | H | I | J | K | L | M | | | |
| 7 | 360-543-70000 | CYLINDER ASSY (JIB, TILT) | - | 1 | | | | | | | | | | | | | | 71 |
| 8 | ***-***-***** | TELESCOPE ASSY (MOUNT) | - | 1 | | | | | | | | | | | | | | 507 |
| 9 | ***-***-***** | ADAPTER ASSY | - | 1 | | | | | | | | | | | | | | 563 |
| 10 | ***-***-***** | BOOM ASSY | - | 1 | | | | | | | | | | | | | | 45 |
| 11 | 342-221-90100 | SUPPORT | - | 1 | | | | | | | | | | | | | | |
| 12 | 370-001-87250 | PIN | - | 2 | | | | | | | | | | | | | | |
| 13 | 344-441-90100 | SUPPORT | - | 2 | | | | | | | | | | | | | | |
| 14 | 344-441-90010 | PIN | - | 2 | | | | | | | | | | | | | | |
| 15 | 344-441-90020 | PIN | - | 2 | | | | | | | | | | | | | | |
| 16 | 342-016-70750 | SUPPORT | - | 2 | | | | | | | | | | | | | | |
| 17 | 997-077-40242 | SHEAVE ASSY (FOR FAUN) | - | 1 | | | | | | | | | | | | | | |
| 18 | 342-221-90200 | COVER | - | 1 | | | | | | | | | | | | | | |
| 19 | 370-001-88180 | PIN | - | 1 | | | | | | | | | | | | | | |
| 20 | 342-221-90300 | SUPPORT | - | 1 | | | | | | | | | | | | | | |
| 21 | 370-001-77020 | PIN | - | 1 | | | | | | | | | | | | | | |
| 22 | 370-001-47120 | PIN | - | 1 | | | | | | | | | | | | | | |
| 23 | 370-002-01110 | PIN, SNAP | - | 2 | | | | | | | | | | | | | | |
| 24 | 370-005-53300 | PLATE | - | 2 | | | | | | | | | | | | | | |
| 25 | 901-015-10025 | BOLT <M10X25> | - | 8 | | | | | | | | | | | | | | |
| 26 | 901-711-12030 | BOLT <M12X30> | - | 6 | | | | | | | | | | | | | | |
| 27 | 903-030-71201 | WASHER, PLAIN <12> | - | 8 | | | | | | | | | | | | | | |
| 28 | 902-092-02400 | NUT <M24> | - | 2 | | | | | | | | | | | | | | |
| 29 | 370-002-00010 | PIN, SNAP | - | 2 | | | | | | | | | | | | | | |
| 30 | 342-209-30100 | SUPPORT | - | 1 | | | | | | | | | | | | | | |
| 31 | 901-711-08030 | BOLT <M8X30> | - | 4 | | | | | | | | | | | | | | |
| 32 | 903-030-70801 | WASHER, PLAIN <8> | - | 4 | | | | | | | | | | | | | | |
| 33 | 370-005-43540 | PLATE | - | 2 | | | | | | | | | | | | | | |
| 34 | 903-030-71001 | WASHER, PLAIN <10> | - | 10 | | | | | | | | | | | | | | |
| 35 | 370-001-47950 | PIN | - | 1 | | | | | | | | | | | | | | |
| 36 | 342-221-90500 | GUIDE | - | 1 | | | | | | | | | | | | | | |
| 37 | 370-001-28440 | PIN | - | 2 | | | | | | | | | | | | | | |
| 38 | 801-363-60050 | PIN, SPLIT <6X50> | - | 4 | | | | | | | | | | | | | | |
| 39 | 370-003-10770 | SPACER | - | 8 | | | | | | | | | | | | | | |
| 42 | 901-012-10016 | BOLT <M10X16> | - | 8 | | | | | | | | | | | | | | |
| 43 | 370-101-03280 | PIN | - | 3 | | | | | | | | | | | | | | |

| 組立名称 Assembly Name | | ジブASSY (マウント) JIB ASSY (MOUNT) | | FIG. PJ505-0052-00 | | | | | | | | | | | | | | |
|-----------------------------|------------------|---|---------------------|--------------------|---|---|---|---|---|---|---|---|---|---|---|----------------|----------------------------|-------------|
| スペック番号 Specification No. | | A < ATF-130G-1-90101 > B < ATF-130G-1-90102 > | | | | | | | | | | | | | | | | |
| 指示番号 Key No. | 部品番号 Part No. | 部品名称 Part Name | Q'ty Per Section 個数 | | | | | | | | | | | | | 実施号機 (変更番号) | Serial No. Modifi. No.) | ページ Page |
| | | | A | B | C | D | E | F | G | H | I | J | K | L | M | | | |
| 44 | 370-101-03490 | PIN | - | 1 | | | | | | | | | | | | | | |
| 45 | 370-101-01960 | PIN <D=55, L=180> | - | 2 | | | | | | | | | | | | | | |
| 46 | 370-002-01950 | PIN, SNAP | - | 6 | | | | | | | | | | | | | | |
| 47 | 824-563-01000 | NIPPLE (GREASE) | - | 2 | | | | | | | | | | | | | | |
| 48 | 370-005-84160 | PLATE | - | 1 | | | | | | | | | | | | | | |
| 49 | 370-002-01090 | PIN, SNAP <20> | - | 1 | | | | | | | | | | | | | | |
| 50 | 370-003-02780 | SPACER | - | 2 | | | | | | | | | | | | | | |
| 51 | 370-019-09170 | ROPE, WIRE (TESAC) <16X1.87M> | - | 4 | | | | | | | | | | | | | | |
| 52 | 831-525-12200 | SHACKLE (SB22) | - | 4 | | | | | | | | | | | | | | |
| 53 | 801-363-50040 | PIN, SPLIT <5X40> | - | 4 | | | | | | | | | | | | | | |
| 54 | 342-221-90800 | SUPPORT | - | 1 | | | | | | | | | | | | | | |
| 55 | 901-711-12035 | BOLT <M12X35> | - | 2 | | | | | | | | | | | | | | |
| 56 | 997-070-22690 | SHEAVE ASSY | - | 1 | | | | | | | | | | | | | | |
| 57 | 370-001-08600 | PIN | - | 1 | | | | | | | | | | | | | | |
| 58 | 370-001-14400 | PIN <D=25, L=106> | - | 2 | | | | | | | | | | | | | | |
| 59 | 370-002-00540 | PIN, SNAP <D=25> | - | 2 | | | | | | | | | | | | | | |
| 60 | 370-005-88840 | SHIM <T=1.2> | - | 10 | | | | | | | | | | | | | | |
| 61 | 370-101-01340 | PIN | - | 1 | | | | | | | | | | | | | | |
| 62 | 801-363-50063 | PIN, SPLIT | - | 1 | | | | | | | | | | | | | | |
| 63 | 370-003-02220 | SPACER | - | 1 | | | | | | | | | | | | | | |
| 81 | 370-010-09430 | SHEAVE ASSY (TADANO) | - | 1 | | | | | | | | | | | | | | |
| 92 | 805-200-45016 | BEARING, ROLLER (IKO NAS5016ZZNR) | - | 1 | | | | | | | | | | | | | | |
| 92 | 805-200-55016 | BEARING, ROLLER (IKO NAS5016UUNR) | - | 1 | | | | | | | | | | | | | | |

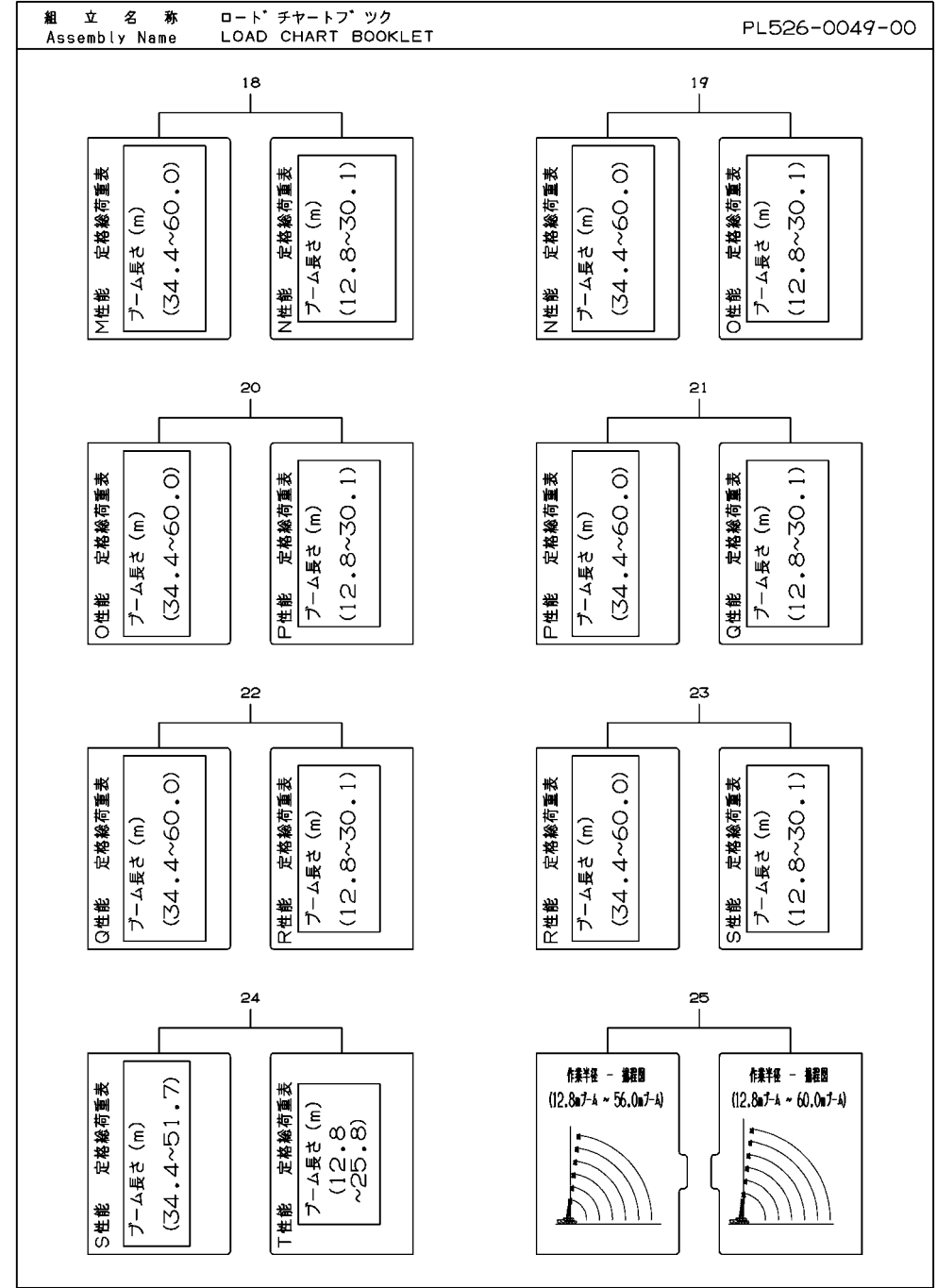
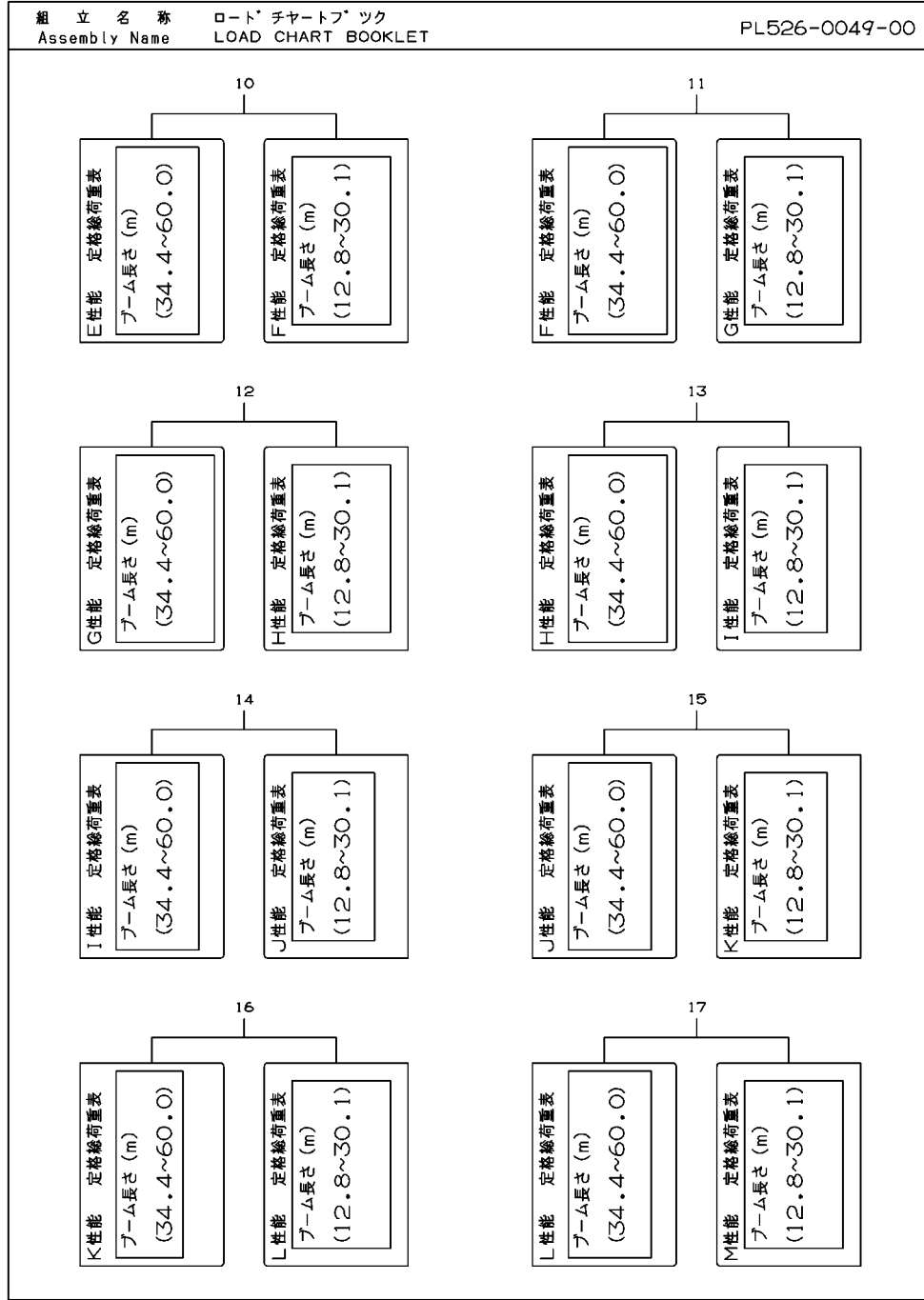

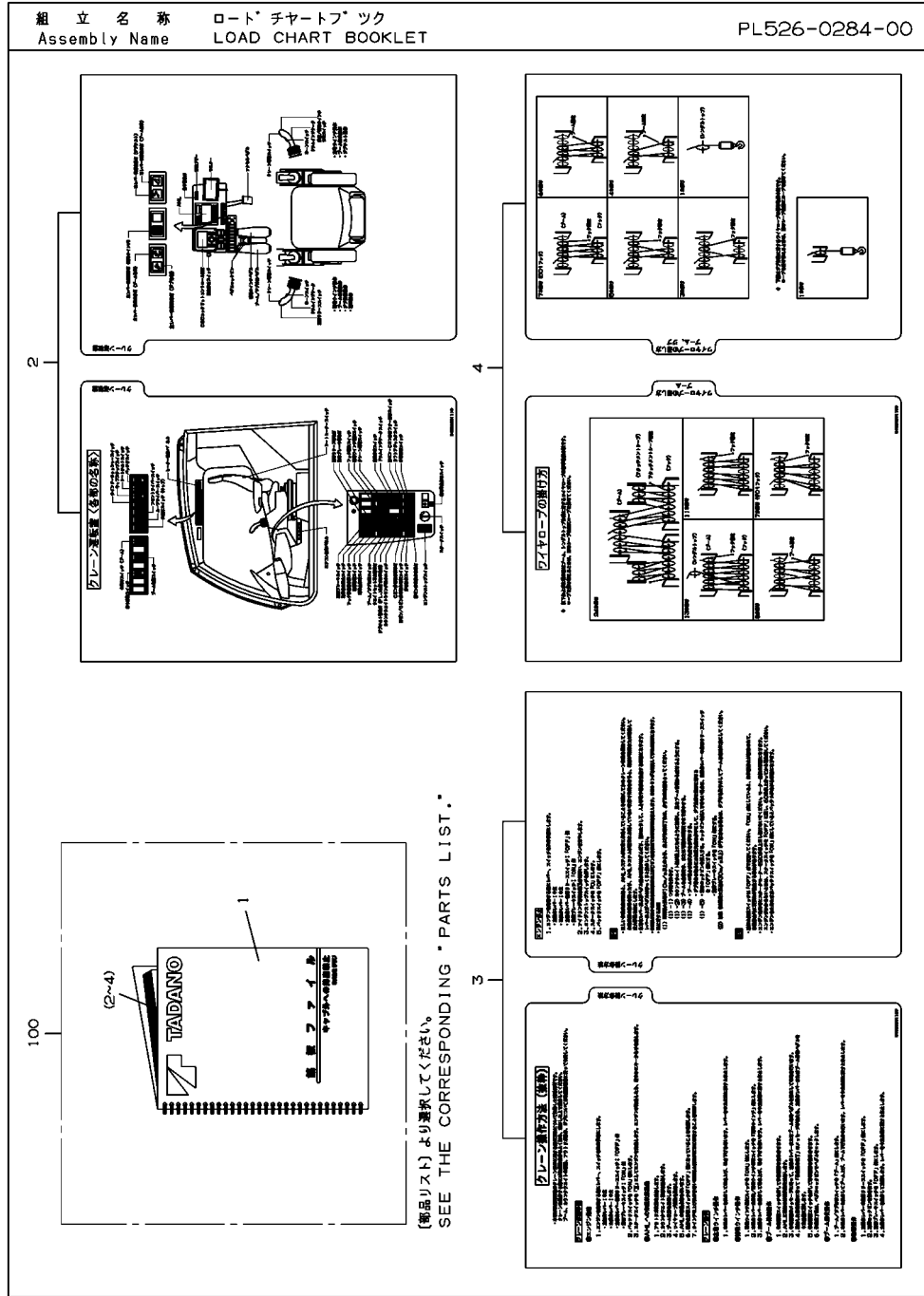

組立名称 ロードチャートブック
 Assembly Name LOAD CHART BOOKLET

FIG. PL526-0284-00

仕様番号 A < ATF-130G-1-90101 > B < ATF-130G-1-90102 >
 Specification No.

| 指示番号 Key No. | 部品番号 Part No. | 部品名称 Part Name | Q'ty Per Section 個数 | | | | | | | | | | | | | | 実施号機 (変更番号) | Serial No. Modifi. No.) | ページ Page | |
|-----------------|------------------|--------------------|---------------------|---|---|---|---|---|---|---|---|---|---|---|---|---|----------------|----------------------------|-------------|---|
| | | | A | B | C | D | E | F | G | H | I | J | K | L | M | N | | | | O |
| 1 | 370-022-30260 | CASE ASSY | - | 1 | | | | | | | | | | | | | | | | |
| 2 | 345-202-51110 | PLATE, NAME | - | 1 | | | | | | | | | | | | | | | | |
| 3 | 345-202-51120 | PLATE, NAME | - | 1 | | | | | | | | | | | | | | | | |
| 4 | 345-202-51130 | PLATE, NAME | - | 1 | | | | | | | | | | | | | | | | |
| 100 | 345-202-51100 | LOAD CHART BOOKLET | - | 1 | | | | | | | | | | | | | | | | |

| | | |
|------------------------------|-------------------------------|---------------|
| 組立名称 Assembly Name | カイツウASSY MODIFICATION ASSY | PM515-0045-00 |
|------------------------------|-------------------------------|---------------|

| 組立名称 Assembly Name | | カイツウASSY (ジブ2センタ) MODIFICATION ASSY (JIB 2 TOP) | | | | | | | | | | FIG. PM515-0045-00 | | | | | | | |
|----------------------------------|--------------------------|--|---------------------|---|---|---|---|---|---|---|---|--------------------|----------------|----------------------------|-------------|---|---|---|---|
| 仕様番号 Specification No. | | A < ATF-130G-1-90101 > B < ATF-130G-1-90102 > | | | | | | | | | | | | | | | | | |
| 指示番号 Key No. | 部品番号 部品名称 | Part No. Part Name | Q'ty Per Section 個数 | | | | | | | | | | 実施号機 (変更番号) | Serial No. Modifi. No.) | ページ Page | | | | |
| | | | A | B | C | D | E | F | G | H | I | J | | | | K | L | M | N |
| 1 | 342-219-70710 SUPPORT | | 1 | | | | | | | | | | | | | | | | |
| | | | | | | | | | | | | | | | | | | | |
| | | | | | | | | | | | | | | | | | | | |
| | | | | | | | | | | | | | | | | | | | |
| | | | | | | | | | | | | | | | | | | | |
| | | | | | | | | | | | | | | | | | | | |
| | | | | | | | | | | | | | | | | | | | |
| | | | | | | | | | | | | | | | | | | | |
| | | | | | | | | | | | | | | | | | | | |

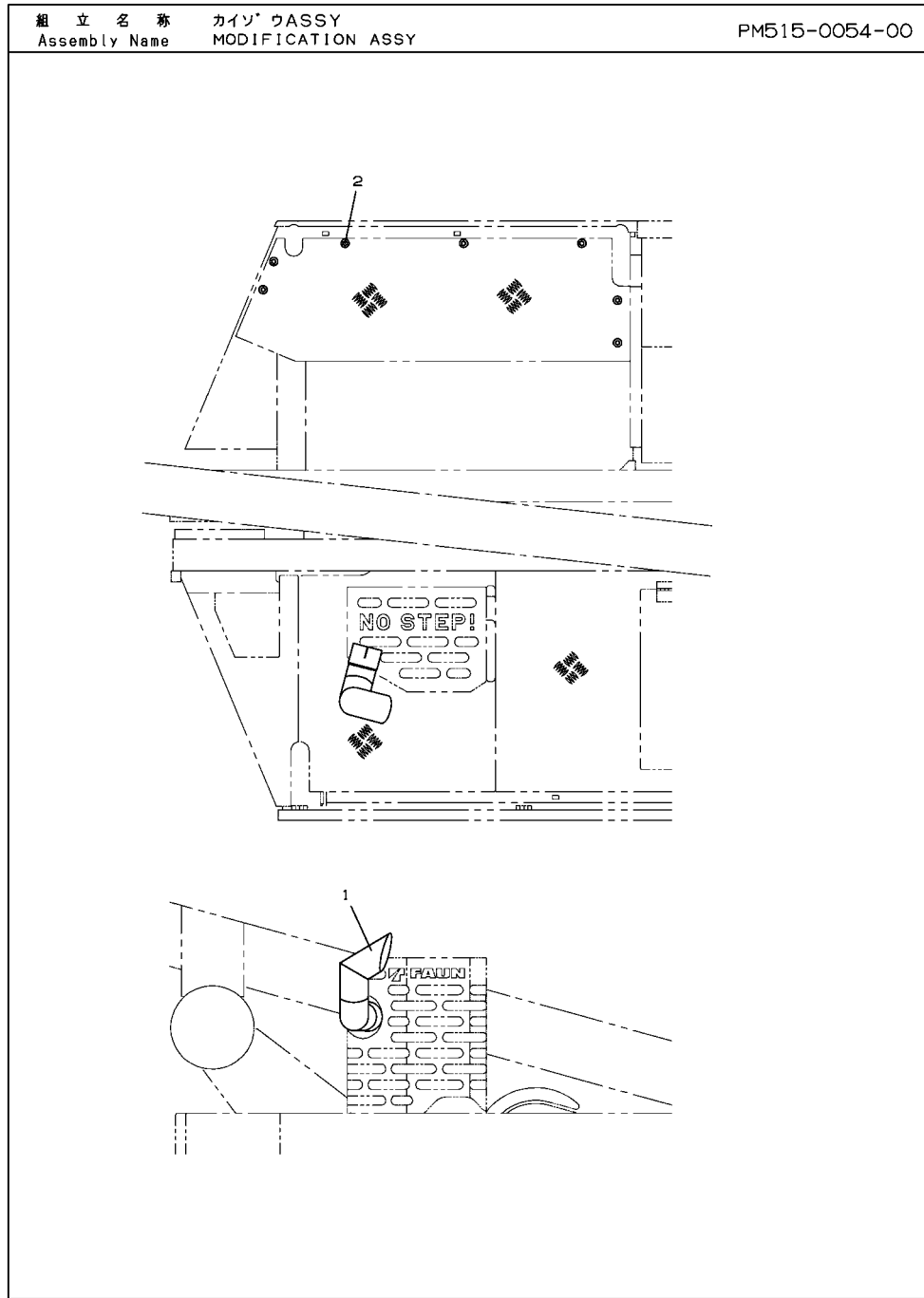

| 組立名称 Assembly Name | | カイツウASSY (マフラー) MODIFICATION ASSY (MUFFLER) | | | | | | | | | | FIG. PM515-0054-00 | | | | | | | | |
|------------------------------------|---------------------------------------|--|---------------------|---|---|---|---|---|---|---|---|--------------------|----------------|----------------------------|-------------|---|---|---|---|---|
| スペック番号 Specification No. | | A < ATF-130G-1-90101 > B < ATF-130G-1-90102 > | | | | | | | | | | | | | | | | | | |
| 指示番号 Key No. | 部品番号 部品名称 | Part No. Part Name | Q'ty Per Section 個数 | | | | | | | | | | 実施号機 (変更番号) | Serial No. Modifi. No.) | ページ Page | | | | | |
| | | | A | B | C | D | E | F | G | H | I | J | | | | K | L | M | N | O |
| 1 | 342-716-82601 PIPE | | 1 | - | | | | | | | | | | | | | | | | |
| 2 | 901-801-08020 BOLT, BUTTON <M8X20> | | 7 | - | | | | | | | | | | | | | | | | |
| | | | | | | | | | | | | | | | | | | | | |
| | | | | | | | | | | | | | | | | | | | | |
| | | | | | | | | | | | | | | | | | | | | |
| | | | | | | | | | | | | | | | | | | | | |
| | | | | | | | | | | | | | | | | | | | | |
| | | | | | | | | | | | | | | | | | | | | |
| | | | | | | | | | | | | | | | | | | | | |
| | | | | | | | | | | | | | | | | | | | | |
| | | | | | | | | | | | | | | | | | | | | |

CLICK HERE TO **DOWNLOAD** THE COMPLETE MANUAL

- Thank you very much for reading the preview of the manual.
- You can download the complete manual from: www.heydownloads.com by clicking the link below



- Please note: If there is no response to CLICKING the link, please download this PDF first and then click on it.

CLICK HERE TO **DOWNLOAD** THE COMPLETE MANUAL

| | | |
|-----------------------|-------------------------------|---------------|
| 組立名称 Assembly Name | カイゾウASSY MODIFICATION ASSY | PM515-0119-00 |
|-----------------------|-------------------------------|---------------|

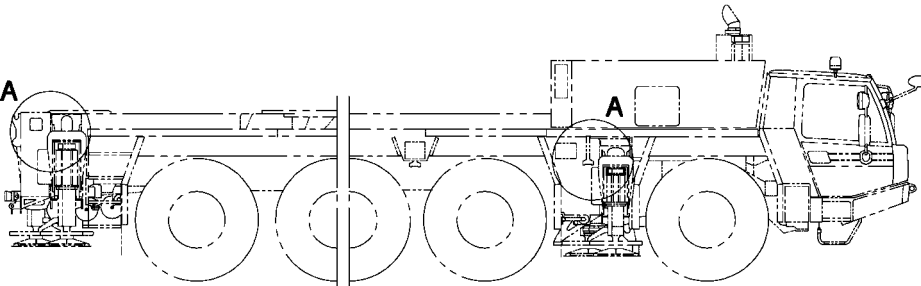

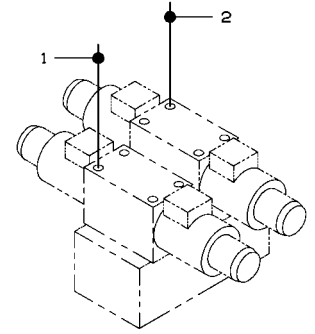

A
アウトリガ操作ソレノイドバルブ

| 組立名称 Assembly Name | カイゾウASSY (O/Rリカサヨクソレノイド・ホデイコチヨクボルトコウカン) MODIFICATION ASSY | FIG. PM515-0119-00 | | | | | | | | | | | | | | | | | | |
|---------------------------|--|------------------------------|---------------------|----|---|---|---|---|---|---|---|---|---|---|---|---|----------------|----------------------------|-------------|---|
| 仕様番号 Specification No. | A < ATF-130G-1-90101 > B < ATF-130G-1-90102 > | | | | | | | | | | | | | | | | | | | |
| 指示番号 Key No. | 部品番号 Part No. | 部品名称 Part Name | Q'ty Per Section 個数 | | | | | | | | | | | | | | 実施号機 (変更番号) | Serial No. Modifi. No.) | ページ Page | |
| | | | A | B | C | D | E | F | G | H | I | J | K | L | M | N | | | | O |
| 1 | 901-721-05030 | BOLT, HEXAGON SOCKET <M5X30> | 16 | 16 | | | | | | | | | | | | | | | | |
| 2 | 901-721-05070 | BOLT, HEXAGON SOCKET <M5X70> | 16 | 16 | | | | | | | | | | | | | | | | |
| | | | | | | | | | | | | | | | | | | | | |
| | | | | | | | | | | | | | | | | | | | | |
| | | | | | | | | | | | | | | | | | | | | |
| | | | | | | | | | | | | | | | | | | | | |
| | | | | | | | | | | | | | | | | | | | | |
| | | | | | | | | | | | | | | | | | | | | |
| | | | | | | | | | | | | | | | | | | | | |
| | | | | | | | | | | | | | | | | | | | | |
| | | | | | | | | | | | | | | | | | | | | |
| | | | | | | | | | | | | | | | | | | | | |
| | | | | | | | | | | | | | | | | | | | | |

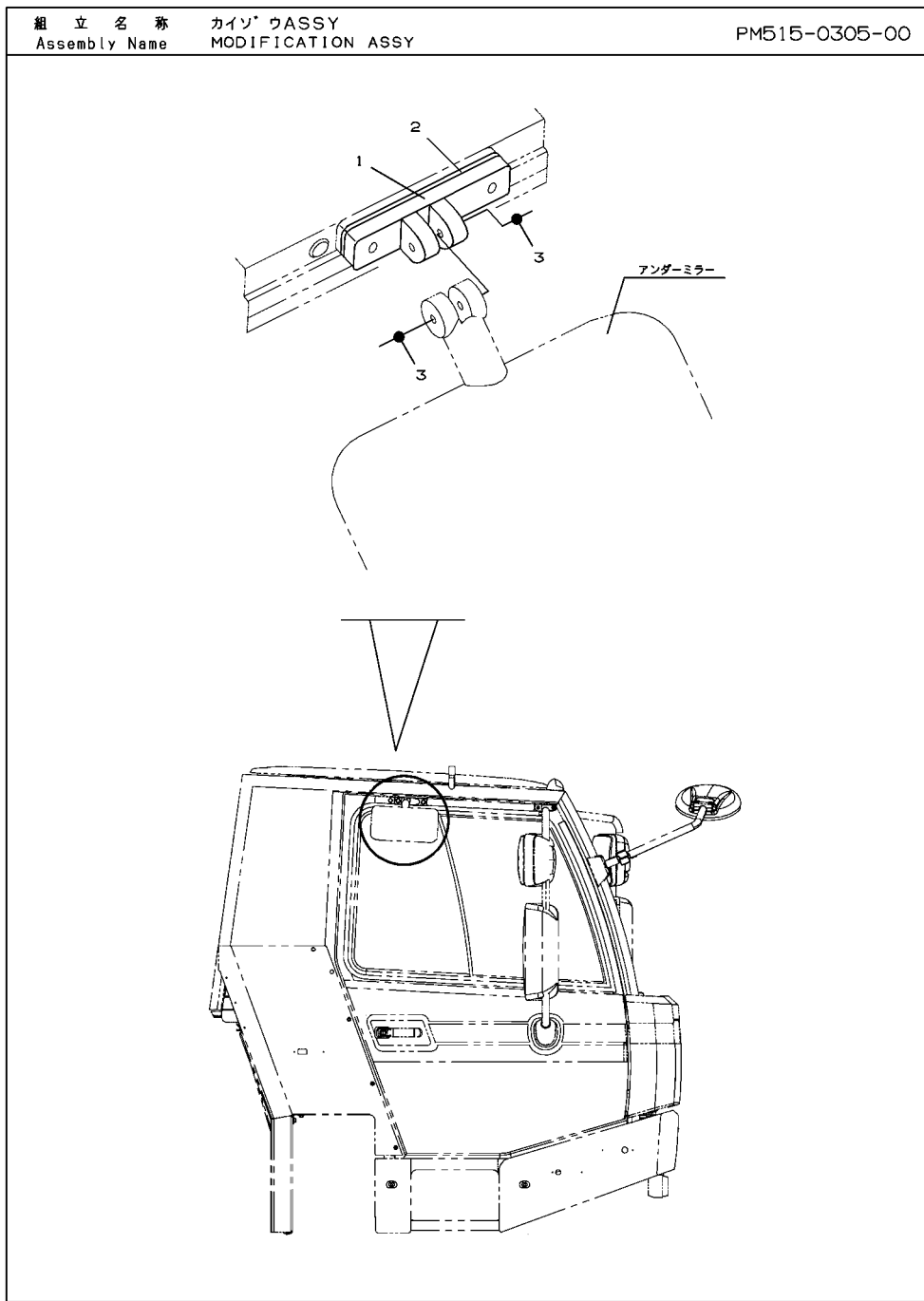

| 組立名称 Assembly Name | | カイソウASSY (サイドアンダーミラーコネクティング) MODIFICATION ASSY (SIDE UNDER MIRROR, FOR FIXED) | | | | | | | | | | FIG. PM515-0305-00 | | | | | | |
|----------------------------------|---|--|--------------------|---|---|---|---|---|---|---|---|---------------------------|----------------|----------------------------|-------------|---|---|---|
| 仕様番号 Specification No. | | A < ATF-130G-1-90101 > B < ATF-130G-1-90102 > | | | | | | | | | | | | | | | | |
| 指示番号 Key No. | 部品番号 部品名称 | Part No. Part Name | Qty Per Section 個数 | | | | | | | | | | 実施号機 (変更番号) | Serial No. Modifi. No.) | ページ Page | | | |
| | | | A | B | C | D | E | F | G | H | I | J | | | | K | L | M |
| 1 | 347-627-81100 SUPPORT | | 1 | 1 | | | | | | | | | | | | | | |
| 2 | 347-627-81200 PLATE | | 1 | 1 | | | | | | | | | | | | | | |
| 3 | 901-315-08016 BOLT, HEXAGON SOCKET <M8X16> | | 2 | 2 | | | | | | | | | | | | | | |
| | | | | | | | | | | | | | | | | | | |
| | | | | | | | | | | | | | | | | | | |
| | | | | | | | | | | | | | | | | | | |
| | | | | | | | | | | | | | | | | | | |
| | | | | | | | | | | | | | | | | | | |
| | | | | | | | | | | | | | | | | | | |
| | | | | | | | | | | | | | | | | | | |
| | | | | | | | | | | | | | | | | | | |
| | | | | | | | | | | | | | | | | | | |

組立名称 カイゾウASSY PM515-0552-01
 Assembly Name MODIFICATION ASSY

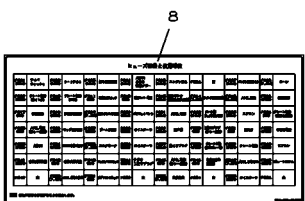
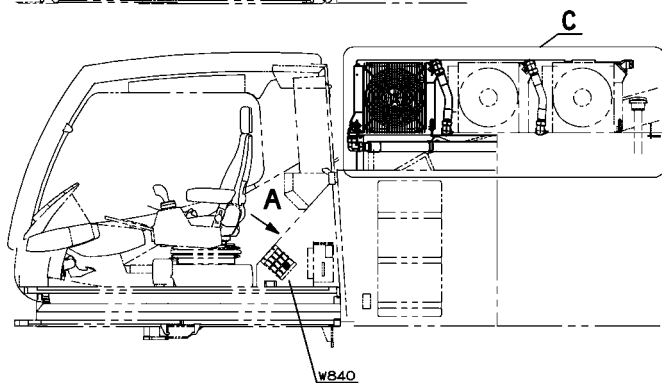
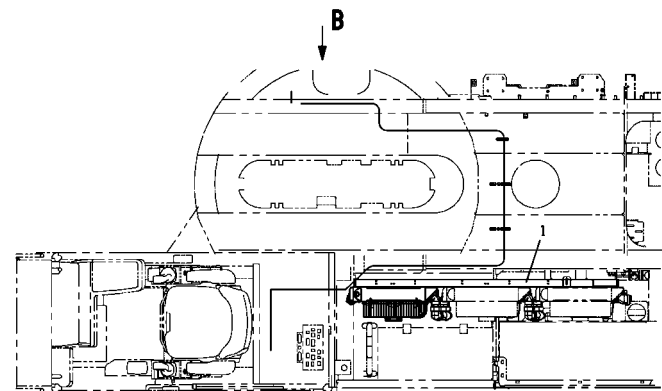

蓋裏面に貼付け

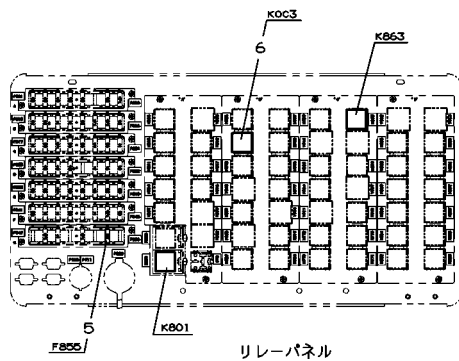
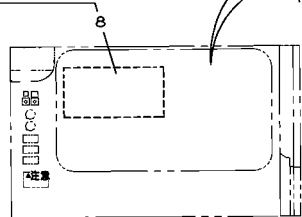

A

組立名称 カイゾウASSY PM515-0552-01
 Assembly Name MODIFICATION ASSY

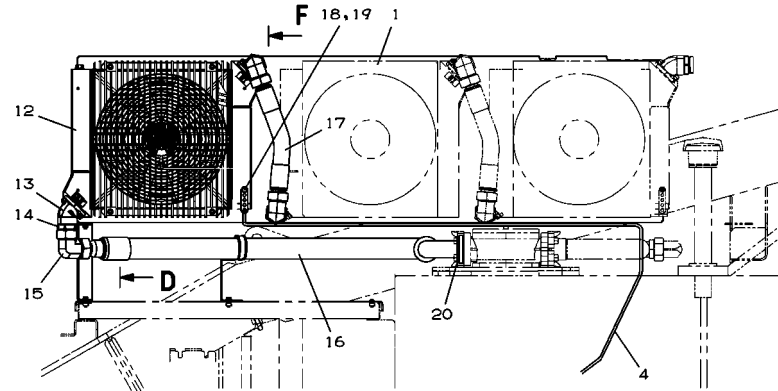

C

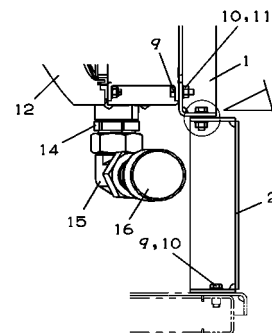

D

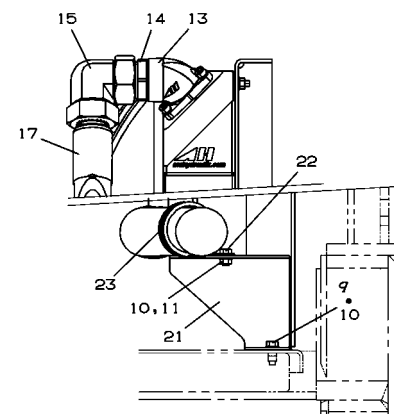

F

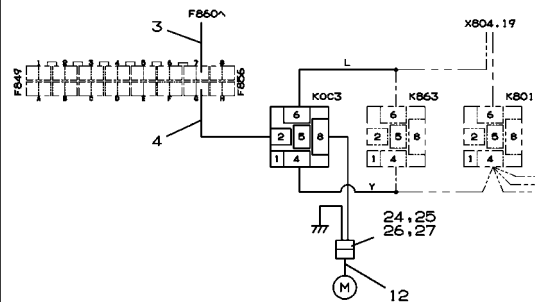

ハーネス施工要領

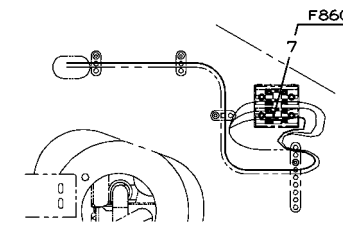

B

| | | | | | | | | |
|--|--|---------------|-----------------|--|---|---|---|---------------------------------|
| 組立名称 Assembly Name | オペ .ASSY,ソウサハ ルフ OPE.ASSY,CONT.VALVE | P0508-0103-00 | | | | | | |
| <table border="1" style="margin-left: auto; margin-right: auto;"> <tr> <td>指示番号 KEY NO.</td> <td>オペ .ASSY,ソウサハ ルフ (ISO/ストレートレバ -) OPE.ASSY,CONT.VALVE (ISO/STRAIGHT LEVER)</td> </tr> <tr> <td>1</td> <td>オペ .ASSY,ソウサハ ルフ OPE.ASSY,CONT.VALVE</td> </tr> <tr> <td>4</td> <td>ネームプ レートASSY NAME PLATE ASSY</td> </tr> </table> | | | 指示番号 KEY NO. | オペ .ASSY,ソウサハ ルフ (ISO/ストレートレバ -) OPE.ASSY,CONT.VALVE (ISO/STRAIGHT LEVER) | 1 | オペ .ASSY,ソウサハ ルフ OPE.ASSY,CONT.VALVE | 4 | ネームプ レートASSY NAME PLATE ASSY |
| 指示番号 KEY NO. | オペ .ASSY,ソウサハ ルフ (ISO/ストレートレバ -) OPE.ASSY,CONT.VALVE (ISO/STRAIGHT LEVER) | | | | | | | |
| 1 | オペ .ASSY,ソウサハ ルフ OPE.ASSY,CONT.VALVE | | | | | | | |
| 4 | ネームプ レートASSY NAME PLATE ASSY | | | | | | | |

| 組立名称 Assembly Name | オペ .ASSY,ソウサハ ルフ (ISO/ストレートレバ -) OPE.ASSY,CONT.VALVE (ISO/STRAIGHT LEVER) | | FIG. P0508-0103-00 | | | | | | | | | | | | | | | | |
|---------------------------|--|---------------------|--------------------|---|---|---|---|---|---|---|---|---|---|---|---|----------------|----------------------------|-------------|-----|
| 仕様番号 Specification No. | A < ATF-130G-1-90101 > B < ATF-130G-1-90102 > | | | | | | | | | | | | | | | | | | |
| 指示番号 Key No. | 部品番号 Part No. | 部品名称 Part Name | Qty Per Section 個数 | | | | | | | | | | | | | 実施号機 (変更番号) | Serial No. Modifi. No.) | ページ Page | |
| | | | A | B | C | D | E | F | G | H | I | J | K | L | M | | | | N |
| 1 | ***-***-***** | OPE.ASSY,CONT.VALVE | 1 | - | | | | | | | | | | | | | | | |
| 4 | ***-***-***** | NAME PLATE ASSY | 1 | - | | | | | | | | | | | | | | | 415 |
| | | | | | | | | | | | | | | | | | | | |
| | | | | | | | | | | | | | | | | | | | |
| | | | | | | | | | | | | | | | | | | | |
| | | | | | | | | | | | | | | | | | | | |
| | | | | | | | | | | | | | | | | | | | |
| | | | | | | | | | | | | | | | | | | | |
| | | | | | | | | | | | | | | | | | | | |
| | | | | | | | | | | | | | | | | | | | |

| | | |
|---|------------------------|---------------|
| 組立名称 Assembly Name | プレート,ネーム PLATE,NAME | PP524-0012-00 |
| <p>当銘板については、弊社出先サービス員経由で御用命ください。</p> <p>FOR THIS NAMEPLATE, CONTACT TADANO DISTRIBUTOR OR DEALER.</p> | | |

| 組立名称 Assembly Name | | プレート,ネーム (タイキジシユケンサステツカー) PLATE, NAME | | | | | | | | | | FIG. PP524-0012-00 | | | | | | |
|------------------------------|-------------------------------------|---|---------------------|---|---|---|---|---|---|---|---|--------------------|----------------|----------------------------|-------------|---|---|---|
| スペック番号 Specification No. | | A < ATF-130G-1-90101 > B < ATF-130G-1-90102 > | | | | | | | | | | | | | | | | |
| 指示番号 Key No. | 部品番号 部品名称 | Part No. Part Name | Q'ty Per Section 個数 | | | | | | | | | | 実施号機 (変更番号) | Serial No. Modifi. No.) | ページ Page | | | |
| | | | A | B | C | D | E | F | G | H | I | J | | | | K | L | M |
| 1 | ***-***-*** PLATE, NAME (タイキケンサ) | | 1 | 1 | | | | | | | | | | | | | | |
| | | | | | | | | | | | | | | | | | | |
| | | | | | | | | | | | | | | | | | | |
| | | | | | | | | | | | | | | | | | | |
| | | | | | | | | | | | | | | | | | | |
| | | | | | | | | | | | | | | | | | | |
| | | | | | | | | | | | | | | | | | | |
| | | | | | | | | | | | | | | | | | | |
| | | | | | | | | | | | | | | | | | | |

| | | |
|-----------------------|-----------------------|---------------|
| 組立名称 Assembly Name | ロープ ASSY ROPE ASSY | PR516-0005-00 |
|-----------------------|-----------------------|---------------|

FLJ脱着用

| 組立名称 Assembly Name | | ロープ ASSY (FLJ ダッチヤケヨカ) ROPE ASSY (FLJ DISMOUNTING) | | | | | FIG. PR516-0005-00 | | | | | | | | | | | | | |
|-----------------------------|--|---|------------------|---|---|---|--------------------|---|---|---|---|---|----------------|---------------------------|-------------|---|---|---|---|---|
| スペック番号 Specification No. | | A < ATF-130G-1-90101 > B < ATF-130G-1-90102 > | | | | | | | | | | | | | | | | | | |
| 指示番号 Key No. | 部品番号 部品名称 | Part No. Part Name | Q'ty Per Section | | | | | | | | | | 実施号機 (変更番号) | Serial No. Modifi. No. | ページ Page | | | | | |
| | | | A | B | C | D | E | F | G | H | I | J | | | | K | L | M | N | O |
| 1 | 344-627-30200 SUPPORT | | - | 1 | | | | | | | | | | | | | | | | |
| 2 | 370-001-32330 PIN | | - | 1 | | | | | | | | | | | | | | | | |
| 3 | 806-011-10120 RING, RETAINING <S12> | | - | 2 | | | | | | | | | | | | | | | | |
| 4 | 370-019-24480 ROPE <L=15M> | | - | 1 | | | | | | | | | | | | | | | | |
| | | | | | | | | | | | | | | | | | | | | |
| | | | | | | | | | | | | | | | | | | | | |
| | | | | | | | | | | | | | | | | | | | | |
| | | | | | | | | | | | | | | | | | | | | |
| | | | | | | | | | | | | | | | | | | | | |
| | | | | | | | | | | | | | | | | | | | | |
| | | | | | | | | | | | | | | | | | | | | |
| | | | | | | | | | | | | | | | | | | | | |
| | | | | | | | | | | | | | | | | | | | | |
| | | | | | | | | | | | | | | | | | | | | |

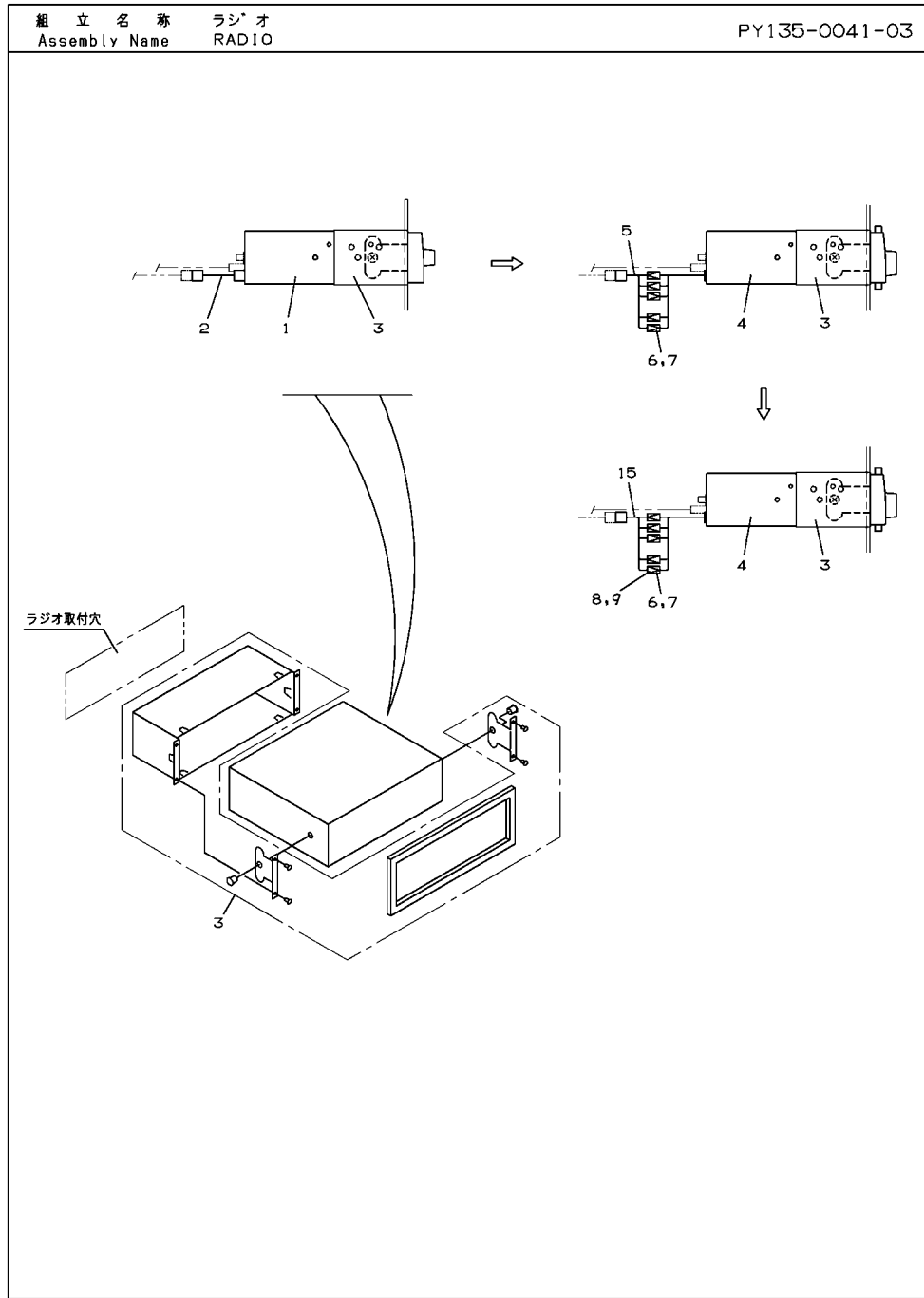

組立名称 ラジオ (キャリアキャブ)
 Assembly Name RADIO (CARRIER CAB)

FIG. PY135-0041-03

仕様番号 A < ATF-130G-1-90101 > B < ATF-130G-1-90102 >
 Specification No.

| 指示番号 Key No. | 部品番号 部品名称 | Part No. Part Name | Qty Per Section 個数 | | | | | | | | | | | | | 実施号機 (変更番号) | Serial No. Modifi. No.) | ページ Page | |
|-----------------|----------------------------------|-----------------------|--------------------|---|---|---|---|---|---|---|---|---|---|---|---|----------------|----------------------------|--|-----|
| | | | A | B | C | D | E | F | G | H | I | J | K | L | M | | | | N |
| 1 | 344-926-51001 RADIO | | 1 | - | | | | | | | | | | | | | (| - 6C5117 - 2258445) | 123 |
| 2 | 344-926-50100 HARNESS | | 1 | - | | | | | | | | | | | | | (| - 6C5117 - 2258445) | |
| 3 | 344-926-50300 SUPPORT | | 1 | 1 | | | | | | | | | | | | | | | |
| 4 | 344-926-52000 RADIO | | - | 1 | | | | | | | | | | | | | | | |
| 4 | 344-926-52000 RADIO | | 1 | - | | | | | | | | | | | | | | 6C5118 - (2260064 -) | |
| 5 | 344-926-50700 HARNESS | | 1 | - | | | | | | | | | | | | | | 6C5118 - 6C5127 (2260064 - 2264672) | 125 |
| 6 | 821-000-00191 TERMINAL | | - | 1 | | | | | | | | | | | | | | | |
| 6 | 821-000-00191 TERMINAL | | 1 | - | | | | | | | | | | | | | | 6C5118 - (2260064 -) | |
| 7 | 821-000-00183 INSULATOR | | - | 1 | | | | | | | | | | | | | | | |
| 7 | 821-000-00183 INSULATOR | | 1 | - | | | | | | | | | | | | | | 6C5118 - (2260064 -) | |
| 8 | 821-000-00182 INSULATOR | | - | 1 | | | | | | | | | | | | | | | |
| 8 | 821-000-00182 INSULATOR | | 1 | - | | | | | | | | | | | | | | 6C5128 - (2264672 -) | |
| 9 | 821-000-00192 TERMINAL (MALE) | | - | 1 | | | | | | | | | | | | | | | |
| 9 | 821-000-00192 TERMINAL (MALE) | | 1 | - | | | | | | | | | | | | | | 6C5128 - (2264672 -) | |
| 15 | 344-926-50800 HARNESS | | - | 1 | | | | | | | | | | | | | | | |
| 15 | 344-926-50800 HARNESS | | 1 | - | | | | | | | | | | | | | | 6C5128 - (2264672 -) | |

INDEX - 3

| 部 品 番 号 Part No. | 頁 Page | 指示番号 Key No. | 部 品 番 号 Part No. | 頁 Page | 指示番号 Key No. | 部 品 番 号 Part No. | 頁 Page | 指示番号 Key No. |
|---------------------|-----------|-----------------|---------------------|-----------|-----------------|---------------------|-----------|-----------------|
| 343-633-63200 | 465 | 5 | 343-818-71200 | 88 | 2 | 343-967-10280 | 433 | 72 |
| 343-635-00010 | 462 | 17 | 343-818-71300 | 519 | 8 | 343-970-90160 | 403 | 38 |
| 343-635-00100 | 462 | 5 | 343-818-71400 | 519 | 9 | | 432 | 38 |
| 343-635-00200 | 462 | 6 | 343-818-71600 | 88 | 100 | 343-970-90170 | 403 | 67 |
| 343-639-90100 | 166 | 16 | | 519 | 7 | | 433 | 67 |
| 343-640-10101 | 108 | 100 | 343-912-02060 | 402 | 10 | 343-970-90180 | 403 | 48 |
| | 465 | 1 | | 410 | 32 | | 433 | 48 |
| 343-640-10200 | 465 | 4 | | 432 | 10 | 343-970-90190 | 403 | 68 |
| 343-640-10210 | 466 | 66 | 343-934-90500 | 403 | 60 | | 433 | 68 |
| 343-640-10220 | 466 | 67 | | 433 | 60 | 343-970-90240 | 404 | 79 |
| 343-640-10230 | 466 | 68 | 343-934-90600 | 403 | 61 | | 434 | 79 |
| 343-640-10240 | 466 | 69 | | 433 | 61 | 343-971-45700 | 413 | 1 |
| 343-640-10300 | 465 | 21 | 343-939-26540 | 480 | 3 | 343-974-43100 | 212 | 1 |
| 343-640-10400 | 110 | 100 | 343-939-26550 | 478 | 1 | | 416 | 1 |
| | 466 | 41 | | 482 | 1 | 343-974-43200 | 212 | 2 |
| 343-640-90500 | 386 | 1 | 343-951-41070 | 413 | 5 | 343-976-31010 | 402 | 2 |
| 343-715-21100 | 168 | 5 | 343-957-80030 | 402 | 19 | 343-976-31020 | 402 | 8 |
| 343-726-20100 | 170 | 1 | | 432 | 19 | | 432 | 8 |
| 343-726-20200 | 170 | 31 | 343-957-80110 | 403 | 37 | 343-976-31030 | 402 | 6 |
| 343-726-20300 | 170 | 32 | | 432 | 37 | 343-976-31040 | 402 | 7 |
| 343-726-22200 | 526 | 4 | 343-957-80470 | 60 | 3 | 343-976-31050 | 404 | 70 |
| 343-726-22400 | 168 | 6 | 343-967-10040 | 402 | 25 | | 433 | 70 |
| 343-726-29510 | 170 | 11 | | 432 | 25 | 343-976-31060 | 402 | 35 |
| 343-727-21000 | 168 | 1 | 343-967-10050 | 402 | 26 | | 432 | 35 |
| | 526 | 50 | | 432 | 26 | 343-976-31070 | 404 | 69 |
| 343-727-21010 | 526 | 3 | 343-967-10080 | 403 | 39 | | 433 | 69 |
| | 528 | 3 | | 432 | 39 | 343-976-31080 | 402 | 18 |
| 343-727-21020 | 526 | 6 | 343-967-10100 | 403 | 40 | | 432 | 18 |
| | 528 | 6 | | 432 | 40 | 343-976-31090 | 403 | 59 |
| 343-727-23000 | 168 | 3 | 343-967-10110 | 403 | 41 | 343-976-31101 | 402 | 34 |
| 343-727-26000 | 168 | 1 | | 432 | 41 | 343-976-31102 | 402 | 34 |
| | 170 | 5 | 343-967-10230 | 402 | 24 | 343-976-31110 | 403 | 42 |
| | 528 | 50 | | 432 | 24 | | 432 | 42 |
| 343-727-26100 | 528 | 4 | 343-967-10260 | 402 | 32 | 343-976-31120 | 403 | 43 |
| 343-727-29510 | 168 | 7 | | 432 | 32 | | 433 | 43 |
| 343-816-23300 | 514 | 22 | 343-967-10270 | 402 | 33 | 343-976-31130 | 403 | 44 |
| 343-818-71100 | 88 | 1 | | 432 | 33 | | 433 | 44 |
| 343-818-71101 | 88 | 1 | 343-967-10280 | 404 | 72 | 343-976-31140 | 403 | 45 |

INDEX - 3

INDEX - 4

| 部 品 番 号 Part No. | 頁 Page | 指示番号 Key No. | 部 品 番 号 Part No. | 頁 Page | 指示番号 Key No. | 部 品 番 号 Part No. | 頁 Page | 指示番号 Key No. |
|---------------------|-----------|-----------------|---------------------|-----------|-----------------|---------------------|-----------|-----------------|
| 343-976-31140 | 433 | 45 | 343-976-32140 | 195 | 14 | 343-976-33112 | 210 | 11 |
| 343-976-31150 | 403 | 46 | 343-976-32150 | 195 | 15 | 343-976-33121 | 202 | 12 |
| | 433 | 46 | 343-976-32160 | 195 | 16 | 343-976-33122 | 210 | 12 |
| 343-976-31160 | 403 | 47 | 343-976-32170 | 195 | 17 | 343-976-33131 | 202 | 13 |
| | 433 | 47 | 343-976-32180 | 195 | 18 | 343-976-33132 | 210 | 13 |
| 343-976-31170 | 404 | 73 | 343-976-32190 | 195 | 19 | 343-976-33141 | 202 | 14 |
| | 433 | 73 | 343-976-32200 | 195 | 20 | 343-976-33142 | 210 | 14 |
| 343-976-31180 | 403 | 49 | 343-976-32210 | 195 | 21 | 343-976-33151 | 202 | 15 |
| | 433 | 49 | 343-976-32220 | 195 | 22 | 343-976-33152 | 210 | 15 |
| 343-976-31190 | 403 | 50 | 343-976-32230 | 195 | 23 | 343-976-33161 | 202 | 16 |
| | 433 | 50 | 343-976-32240 | 195 | 24 | 343-976-33162 | 210 | 16 |
| 343-976-31200 | 68 | 6 | 343-976-32250 | 195 | 25 | 343-976-33172 | 202 | 17 |
| | 403 | 51 | 343-976-33001 | 202 | 50 | 343-976-33173 | 210 | 17 |
| | 433 | 51 | | 413 | 15 | 343-976-33181 | 202 | 18 |
| 343-976-31210 | 403 | 52 | 343-976-33002 | 210 | 50 | 343-976-33182 | 210 | 18 |
| | 433 | 52 | | 413 | 15 | 343-976-33191 | 202 | 19 |
| 343-976-31220 | 403 | 53 | 343-976-33011 | 202 | 1 | 343-976-33192 | 210 | 19 |
| | 433 | 53 | 343-976-33012 | 210 | 1 | 343-976-33201 | 202 | 20 |
| 343-976-31230 | 68 | 7 | 343-976-33013 | 210 | 1 | 343-976-33202 | 210 | 20 |
| 343-976-31240 | 68 | 8 | 343-976-33021 | 202 | 2 | 343-976-33211 | 202 | 21 |
| 343-976-31250 | 404 | 75 | 343-976-33022 | 210 | 2 | 343-976-33212 | 210 | 21 |
| | 433 | 75 | 343-976-33031 | 202 | 3 | 343-976-33222 | 202 | 22 |
| 343-976-32000 | 195 | 50 | 343-976-33032 | 210 | 3 | 343-976-33223 | 210 | 22 |
| | 403 | 58 | 343-976-33042 | 202 | 4 | 343-976-33231 | 202 | 23 |
| 343-976-32010 | 195 | 1 | 343-976-33043 | 210 | 4 | 343-976-33232 | 210 | 23 |
| 343-976-32021 | 195 | 2 | 343-976-33051 | 202 | 5 | 343-976-33241 | 202 | 24 |
| 343-976-32030 | 195 | 3 | 343-976-33052 | 210 | 5 | | 210 | 24 |
| 343-976-32040 | 195 | 4 | 343-976-33061 | 202 | 6 | 343-976-33251 | 202 | 25 |
| 343-976-32050 | 195 | 5 | 343-976-33062 | 210 | 6 | | 210 | 25 |
| 343-976-32051 | 195 | 5 | 343-976-33071 | 202 | 7 | 343-976-33261 | 202 | 26 |
| 343-976-32060 | 195 | 6 | 343-976-33072 | 210 | 7 | | 210 | 26 |
| 343-976-32070 | 195 | 7 | 343-976-33081 | 202 | 8 | 343-976-34010 | 413 | 3 |
| 343-976-32080 | 195 | 8 | 343-976-33082 | 210 | 8 | 343-976-34020 | 413 | 12 |
| 343-976-32090 | 195 | 9 | 343-976-33091 | 202 | 9 | 343-976-34030 | 413 | 13 |
| 343-976-32100 | 195 | 10 | 343-976-33092 | 210 | 9 | 343-976-34040 | 413 | 11 |
| 343-976-32110 | 195 | 11 | 343-976-33101 | 202 | 10 | 343-976-34050 | 413 | 2 |
| 343-976-32120 | 195 | 12 | 343-976-33102 | 210 | 10 | 343-976-34060 | 413 | 10 |
| 343-976-32130 | 195 | 13 | 343-976-33111 | 202 | 11 | 343-976-34070 | 413 | 17 |

INDEX - 4

CLICK HERE TO **DOWNLOAD** THE COMPLETE MANUAL

- Thank you very much for reading the preview of the manual.
- You can download the complete manual from: www.heydownloads.com by clicking the link below



- Please note: If there is no response to CLICKING the link, please download this PDF first and then click on it.

CLICK HERE TO **DOWNLOAD** THE COMPLETE MANUAL