

**TM-ZR580 41109220140 BOOM/5 SECT.,HOOK-IN**  
PB0000201-02 SYSTEM (ZR580,DOMESTIC)  
ASSEMBLY

CLICK HERE TO **DOWNLOAD** THE COMPLETE MANUAL

- Thank you very much for reading the preview of the manual.
- You can download the complete manual from: [www.heydownloads.com](http://www.heydownloads.com) by clicking the link below



- Please note: If there is no response to CLICKING the link, please download this PDF first and then click on it.

CLICK HERE TO **DOWNLOAD** THE COMPLETE MANUAL

# TM-ZR580 41109220140 BOOM/5 SECT.,HOOK-IN

Pos No.	Parts No	Parts Name	Qty	Unit	Technical Data	Serial No (Start)	Serial No (End)	Remarks	Pages
1	37000105070	PIN	1						
2	90101210016	BOLT	1		M10X16				
3	90302041001	WASHER,SPRING	1		10				
4	37002600200	WEDGE	1		10				
5	37002600110	SOCKET,ROPE	1		10&11.2				
6	83151411000	CLIP	1						

TM-ZR580 41109220140 BOOM/5 SECT.,HOOK-IN  
PG1050437-08 CYLINDER,TELESCOPING

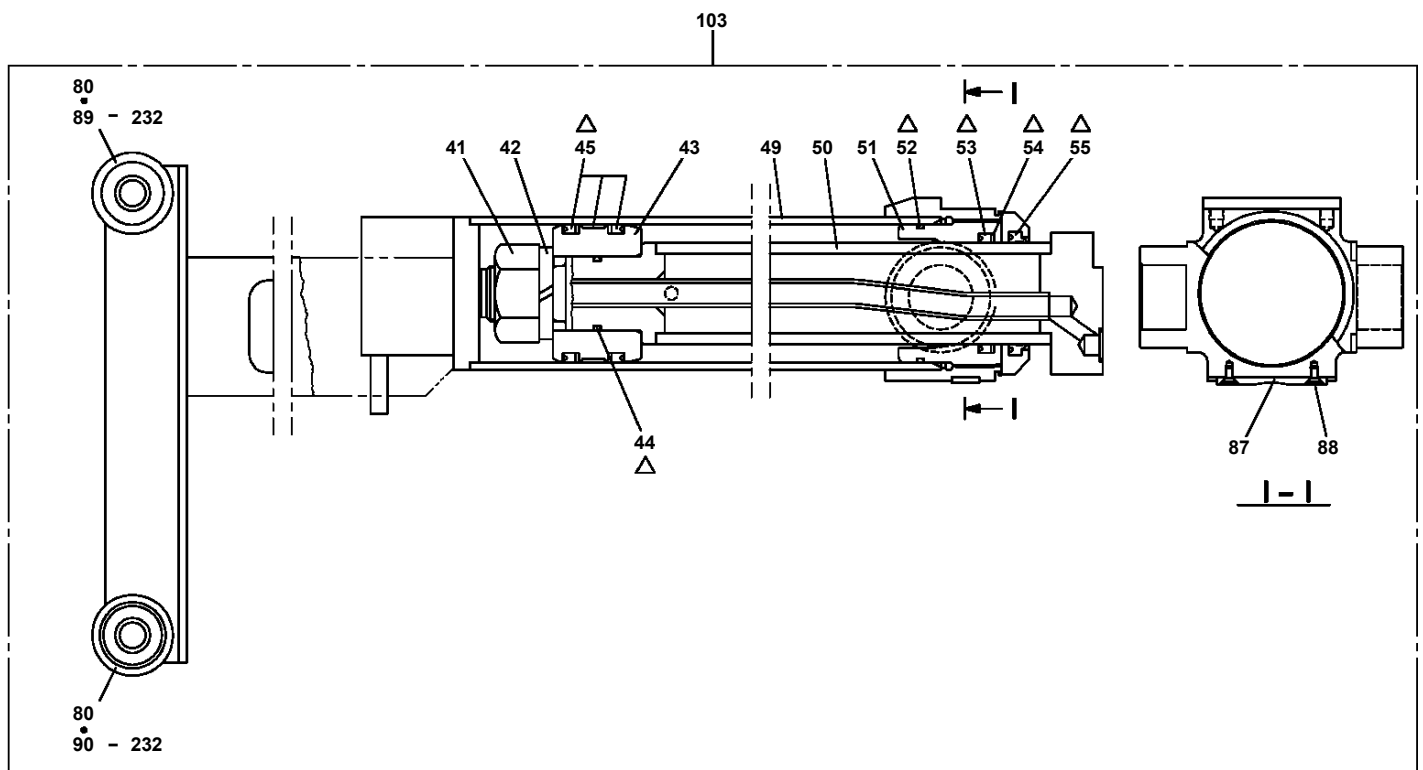

△:PACKING SET KEY NO.113; (KEY NO.44,45,52,53,54,55)

# TM-ZR580 41109220140 BOOM/5 SECT.,HOOK-IN

Pos No.	Parts No	Parts Name	Qty	Unit	Technical Data	Serial No (Start)	Serial No (End)	Remarks	Page
1	31370255010	PLATE	1				DD4595		
2	31370255020	CASE	1				DD4595		
9	31370255080	BRUSH	1				DD4595		
10	31370255090	PLATE	1				DD4595		
11	80175104012	SCREW,MACHINE	2		M4X12		DD4595		
12	90240200400	NUT,CAP	2		M4		DD4595		
13	90303100401	WASHER,PLAIN	2		4		DD4595		
14	90302040401	WASHER,SPRING	2		4		DD4595		
15	31370255100	RING,SLIP	1				DD4595		
16	82100000080	CORD (1-LINE)	17	M			DD4595		
17	31370255110	WASHER	2				DD4595		
18	90102205008	BOLT	2		M5X8		DD4595		
19	31370255120	GROMMET	1				DD4595		
24	90102205012	BOLT	4		M5X12		DD4595		
25	90201200500	NUT	4		M5		DD4595		
26	90303100501	WASHER,PLAIN	8		5		DD4595		
27	82100000192	TERMINAL	1				DD4595		
28	82100000182	INSULATOR	1				DD4595		
30	82100000191	TERMINAL	1				DD4595		
31	82100000183	INSULATOR	1				DD4595		
41	36160265010	SPRING ASSY	1				DD4595		
110	31370257510	PLATE	1			DD4596			
111	31370257520	SCREW,MACHINE	4		M3X6	DD4596			
112	31370257530	RING,SLIP	1			DD4596			
113	36160265020	CORD ASSY (MAIN)	1		L=16.3M	DD4596			
114	31370257550	WASHER	2			DD4596			
115	90102205008	BOLT	2		M5X8	DD4596			
119	31370257560	BOLT (WITH W)	4		M5X12	DD4596			
120	31370257570	NUT	4			DD4596			
151	31370257580	CASE ASSY	1			DD4596			
152	36160265030	SPRING ASSY	1			DD4596			
153	36160255040	CORD ASSY (SUB)	1			DD4596			
500	36160260000	REEL,CORD	1						

**TM-ZR580 41109220140 BOOM/5 SECT.,HOOK-IN  
PT5130058-01 TELESCOPE ASSY**

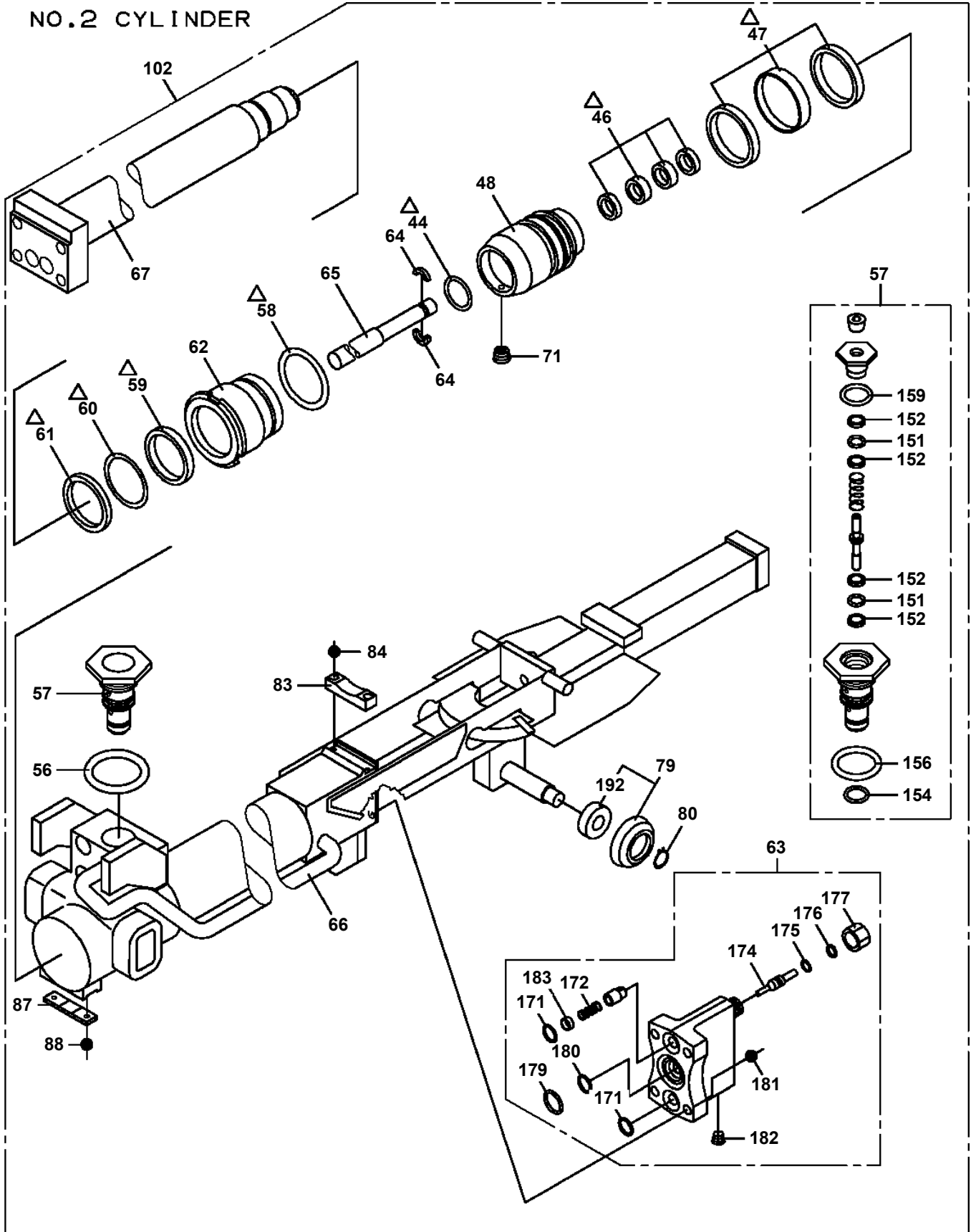

Δ:PACKING SET KEY NO.112 (KEY NO.44,46,47,58,59,60,61)

CLICK HERE TO **DOWNLOAD** THE COMPLETE MANUAL

- Thank you very much for reading the preview of the manual.
- You can download the complete manual from: [www.heydownloads.com](http://www.heydownloads.com) by clicking the link below



- Please note: If there is no response to CLICKING the link, please download this PDF first and then click on it.

CLICK HERE TO **DOWNLOAD** THE COMPLETE MANUAL