

**AT-146-2 42095223100 LOWER,MITSUBISHI PA-FE73DBY 6K3**

PO1000127-01 INDICATION PLATES

PX2000652-00 CARRIER UNIT

ASSEMBLY

CLICK HERE TO **DOWNLOAD** THE COMPLETE MANUAL

- Thank you very much for reading the preview of the manual.
- You can download the complete manual from: [www.heydownloads.com](http://www.heydownloads.com) by clicking the link below



- Please note: If there is no response to CLICKING the link, please download this PDF first and then click on it.

CLICK HERE TO **DOWNLOAD** THE COMPLETE MANUAL

# AT-146-2 42095223100 LOWER,MITSUBISHI PA-FE73DBY 6K3

Pos No.	Parts No	Parts Name	Qty	Unit	Technical Data	Serial No (Start)	Serial No (End)	Remarks	Pages
1	44340011200	JOINT	1		PF1				
2	91002802900	O-RING	1		1B P29				
3	36625520000	VALVE,CHECK	1						000012
	36625510000	VALVE,CHECK	1						000011
4	91002801800	O-RING	1		1B P18				
5	37002513300	HOSE	1		L=535				
6	91803600400	CLIP	4		D=27-40				
7	37002464530	HOSE	1		L=1250				
8	82100002018	CLAMP	2		WR35				
9	82100002016	CLAMP	1		WR25				
10	90186208020	BOLT,FLANGE	2		M8X20				
11	90280200800	NUT,FLANGE	1		M8				

**AT-146-2 42095223100 LOWER, MITSUBISHI PA-FE73DBY 6K3  
PI1140189-00 VALVE, CHECK**

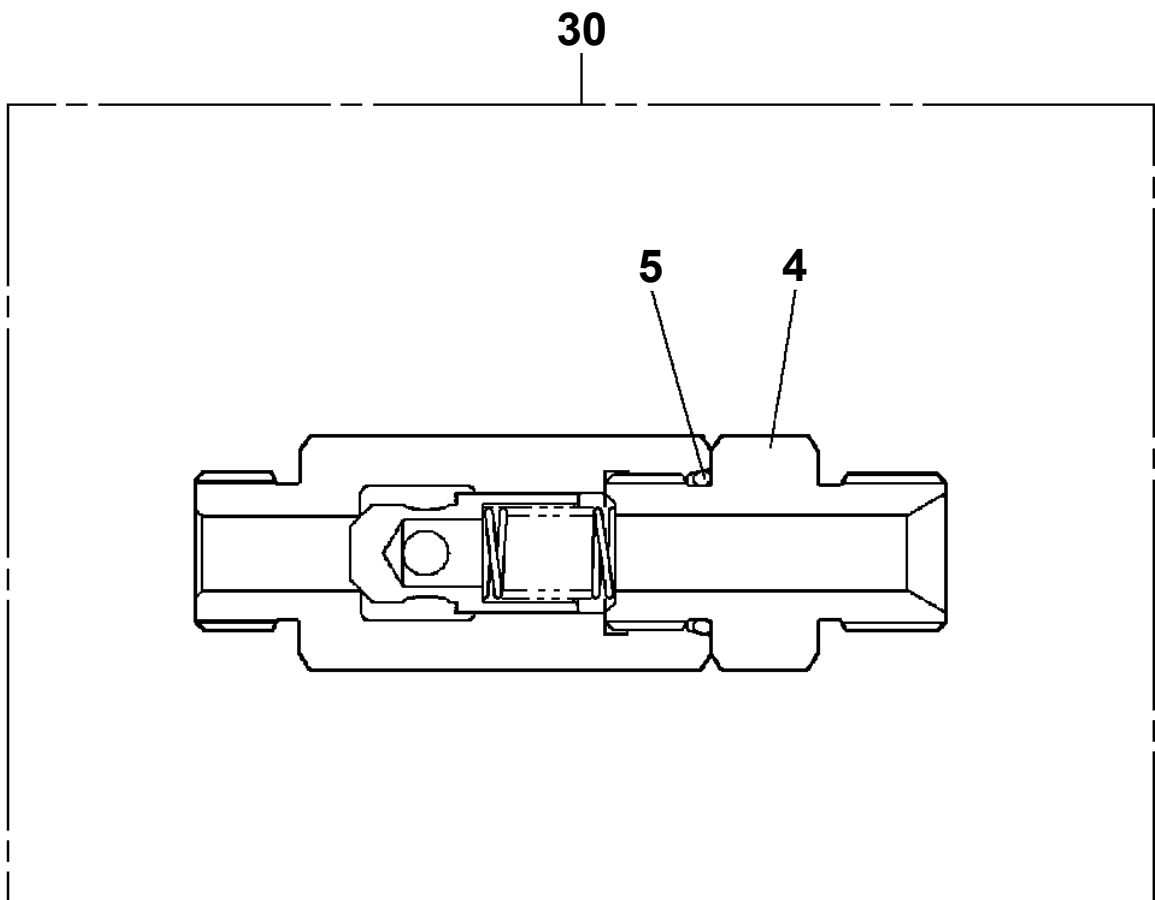



# AT-146-2 42095223100 LOWER,MITSUBISHI PA-FE73DBY 6K3

Pos No.	Parts No	Parts Name	Qty	Unit	Technical Data	Serial No (Start)	Serial No (End)	Remarks	Pages
1	42844050100	WEIGHT	1				228026		
	42844530100	WEIGHT	1			228027			
2	42843700500	WEIGHT	1				228026		
3	90101216090	BOLT	2		M16X90				
4	90101216055	BOLT	2		M16X55				
5	90101216065	BOLT	2		M16X65		228026		
6	90302041601	WASHER,SPRING	6		16		228026		
	90302041601	WASHER,SPRING	4		16	228027			
7	42844750100	WEIGHT	1						
8	90171110030	BOLT	4		M10X30				
9	90302041001	WASHER,SPRING	4		10				

CLICK HERE TO **DOWNLOAD** THE COMPLETE MANUAL

- Thank you very much for reading the preview of the manual.
- You can download the complete manual from: [www.heydownloads.com](http://www.heydownloads.com) by clicking the link below



- Please note: If there is no response to CLICKING the link, please download this PDF first and then click on it.

CLICK HERE TO **DOWNLOAD** THE COMPLETE MANUAL