



Carro miscelatore distributore
Mixer/distributor car

Mischer/Verteiler-Wagen
Chariot mélangeur distributeur

Dunker TW

Dunker TW Split

16-18-21-25 m³

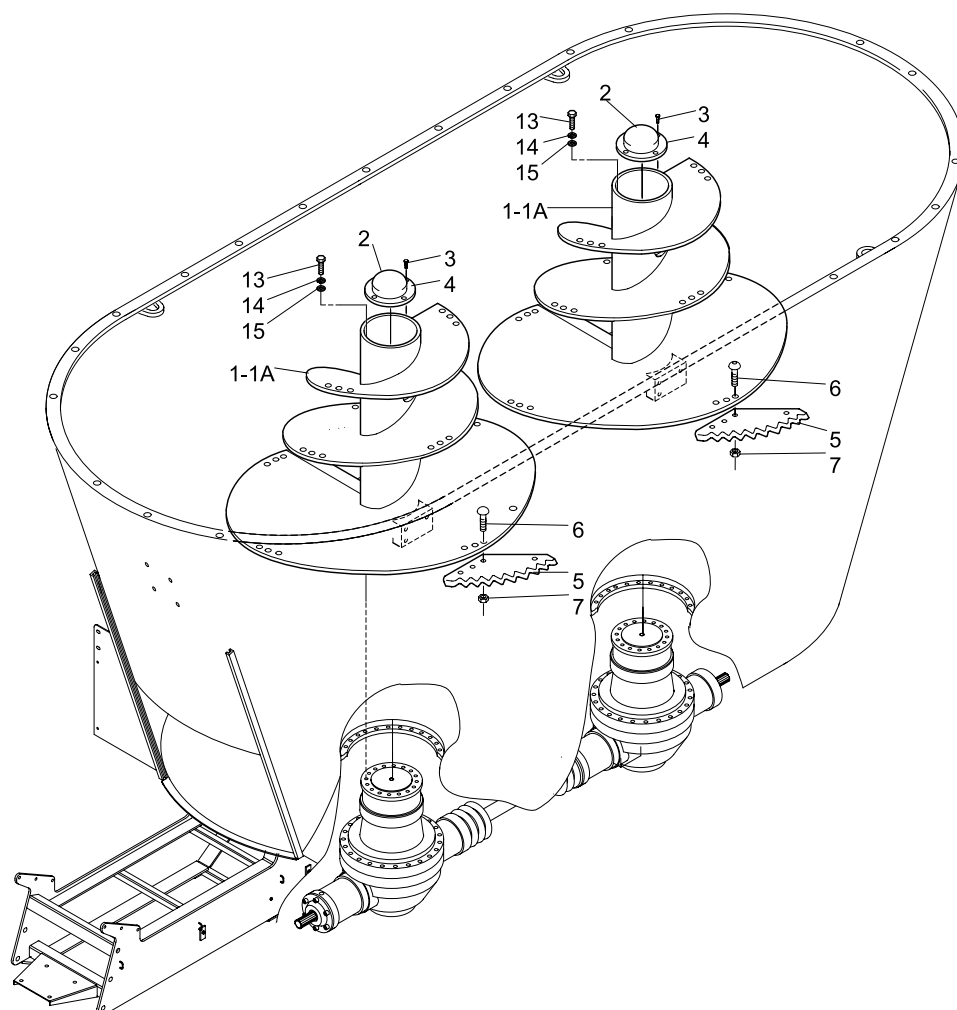

Catalogo ricambi / Spare Parts List
Ersatzteilkatalog / Catalogue Pieces de Rechange

CLICK HERE TO **DOWNLOAD** THE COMPLETE MANUAL

- Thank you very much for reading the preview of the manual.
- You can download the complete manual from: www.heydownloads.com by clicking the link below



- Please note: If there is no response to CLICKING the link, please download this PDF first and then click on it.

CLICK HERE TO **DOWNLOAD** THE COMPLETE MANUAL

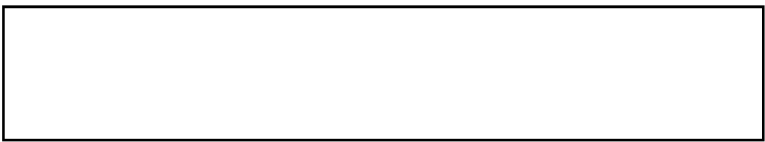

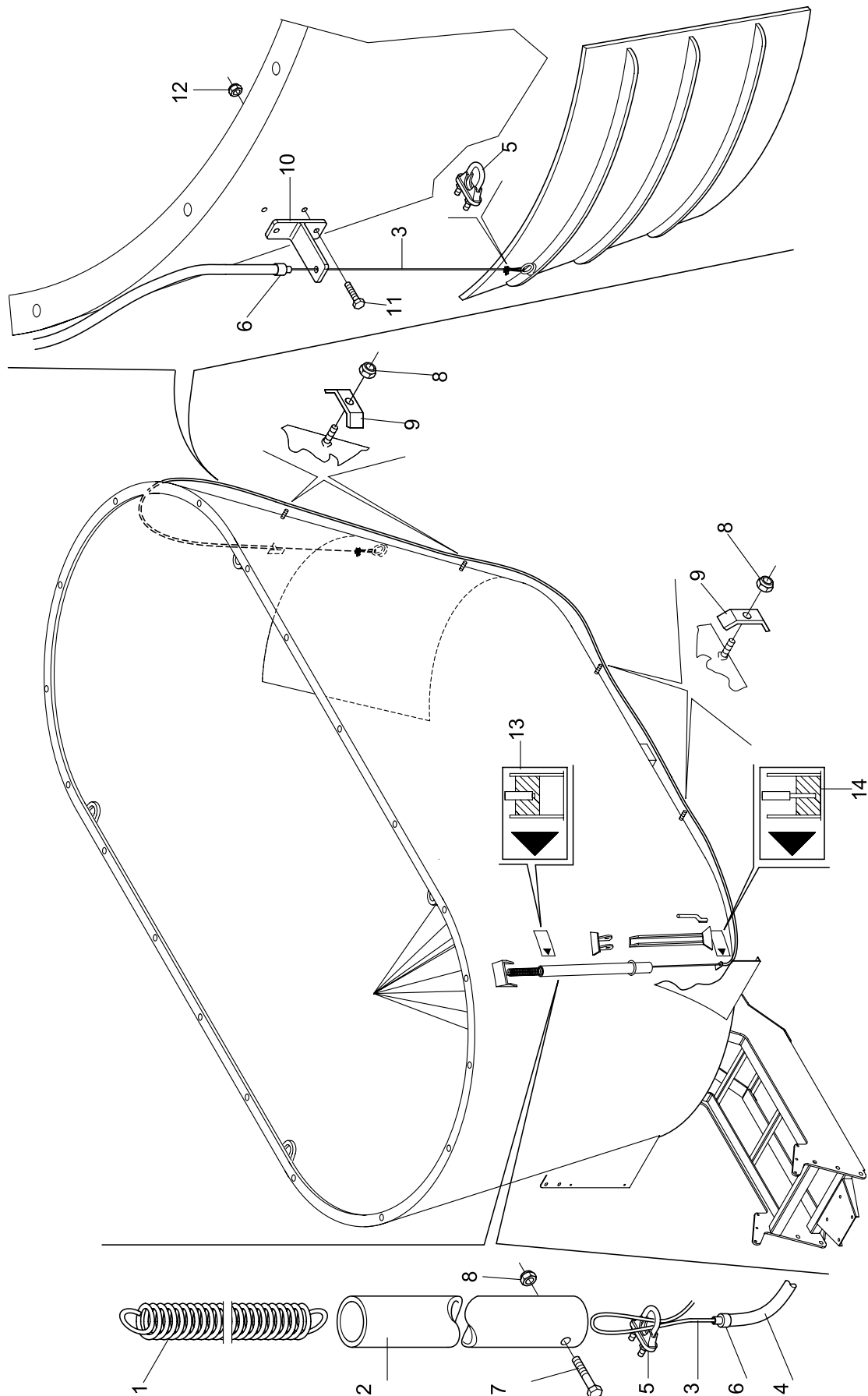

OPTIONAL PER COCLEA "SPRINT"
OPTIONAL FOR "SPRINT" ARCHIMED. SCREW

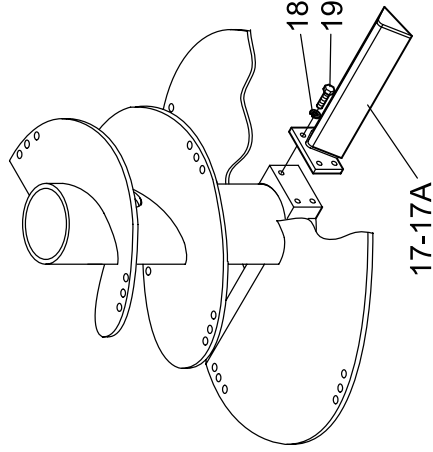

PER 21 - 25 m³
FOR 21 - 25 m³

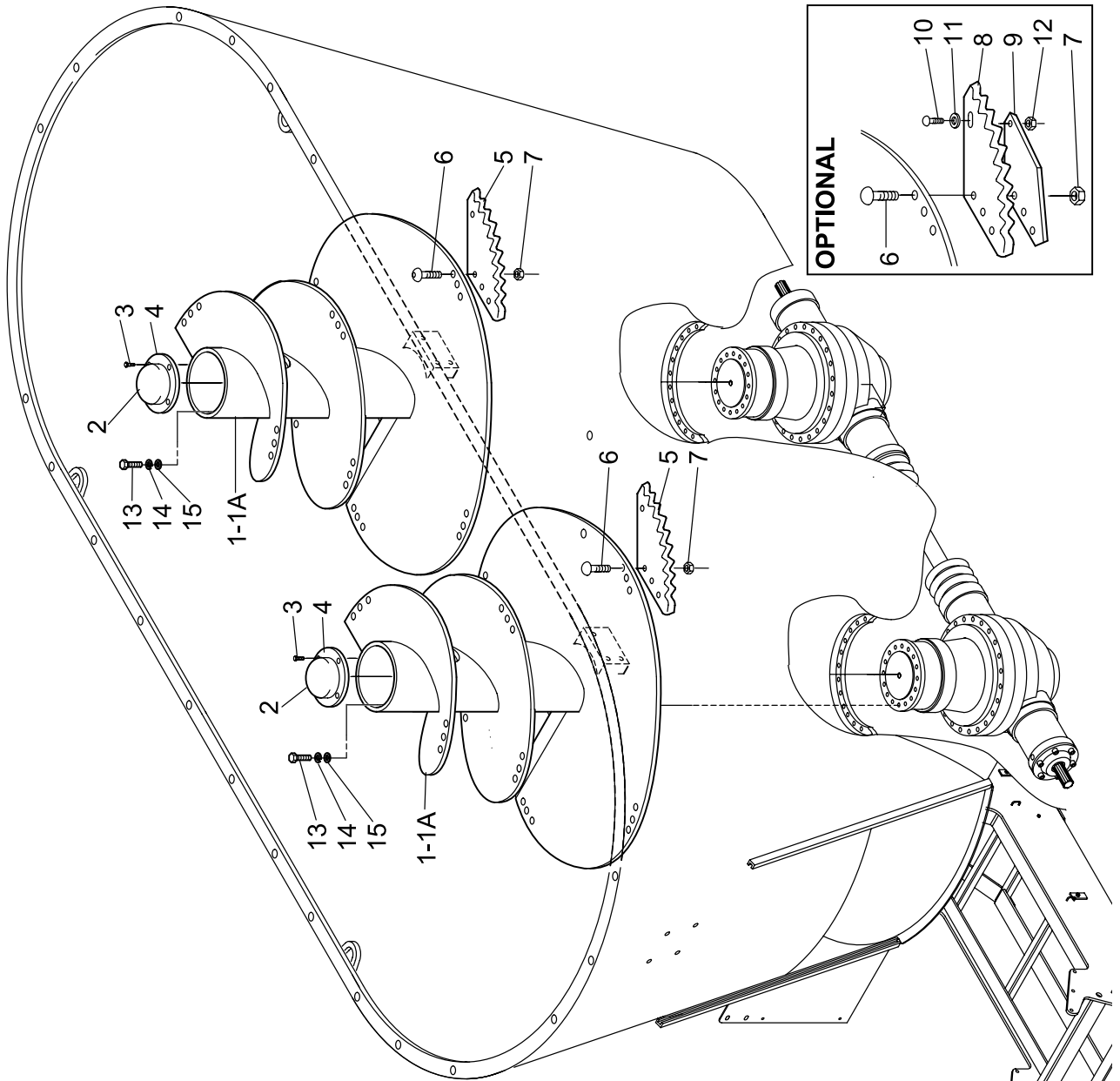
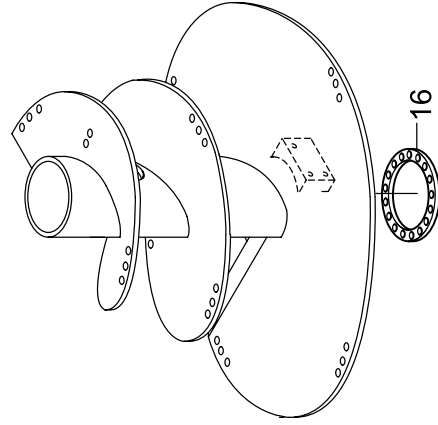

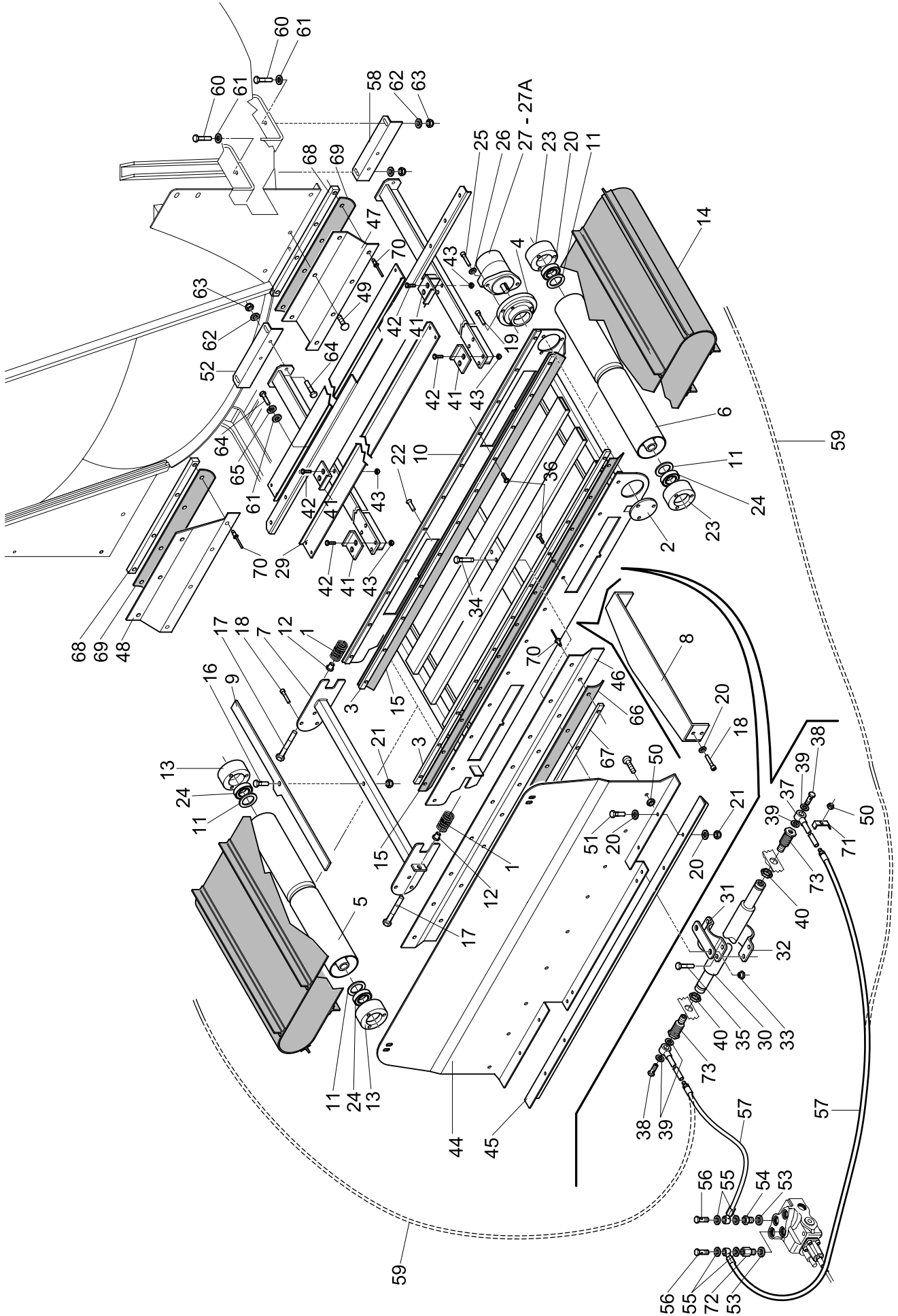

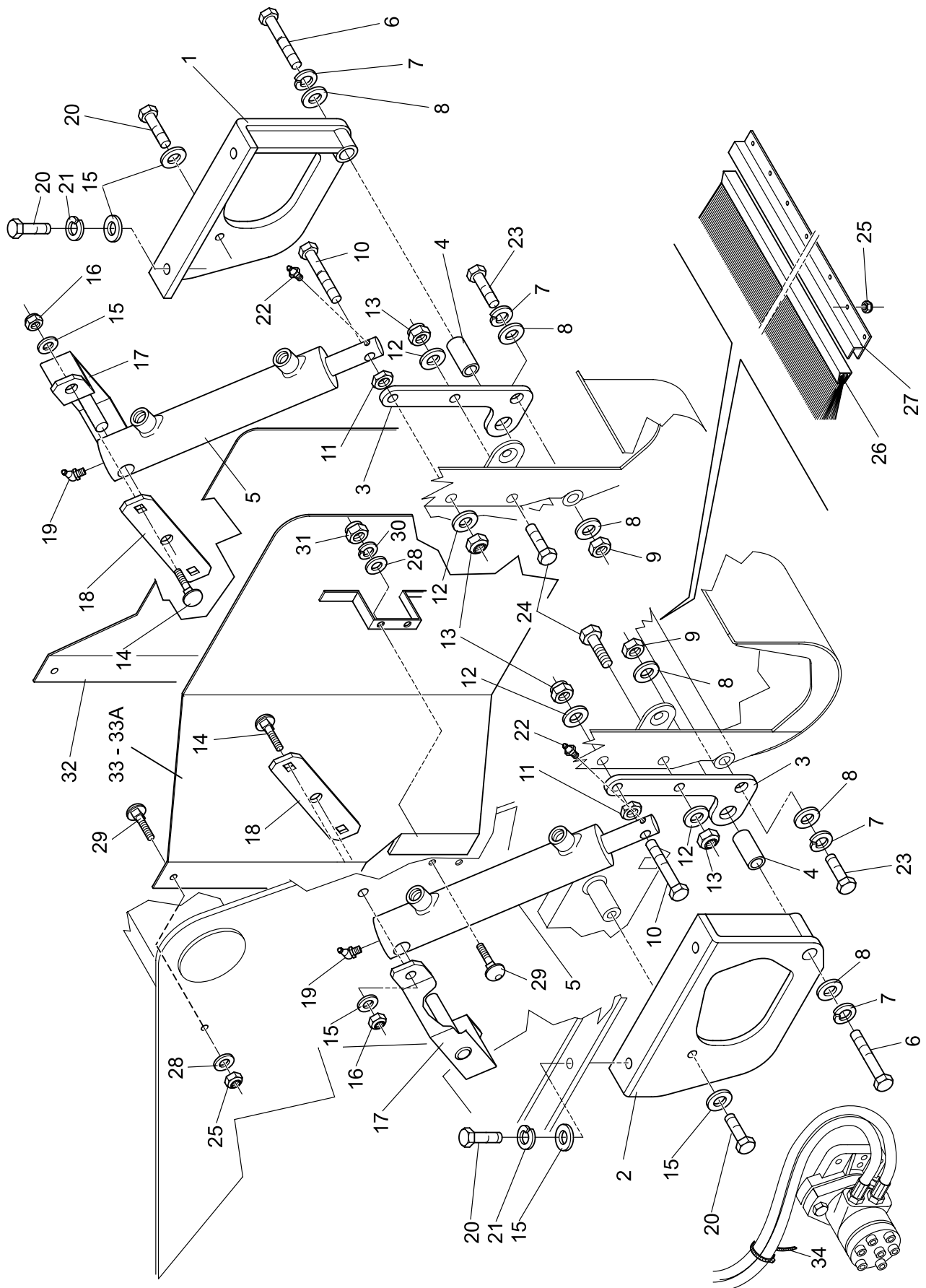

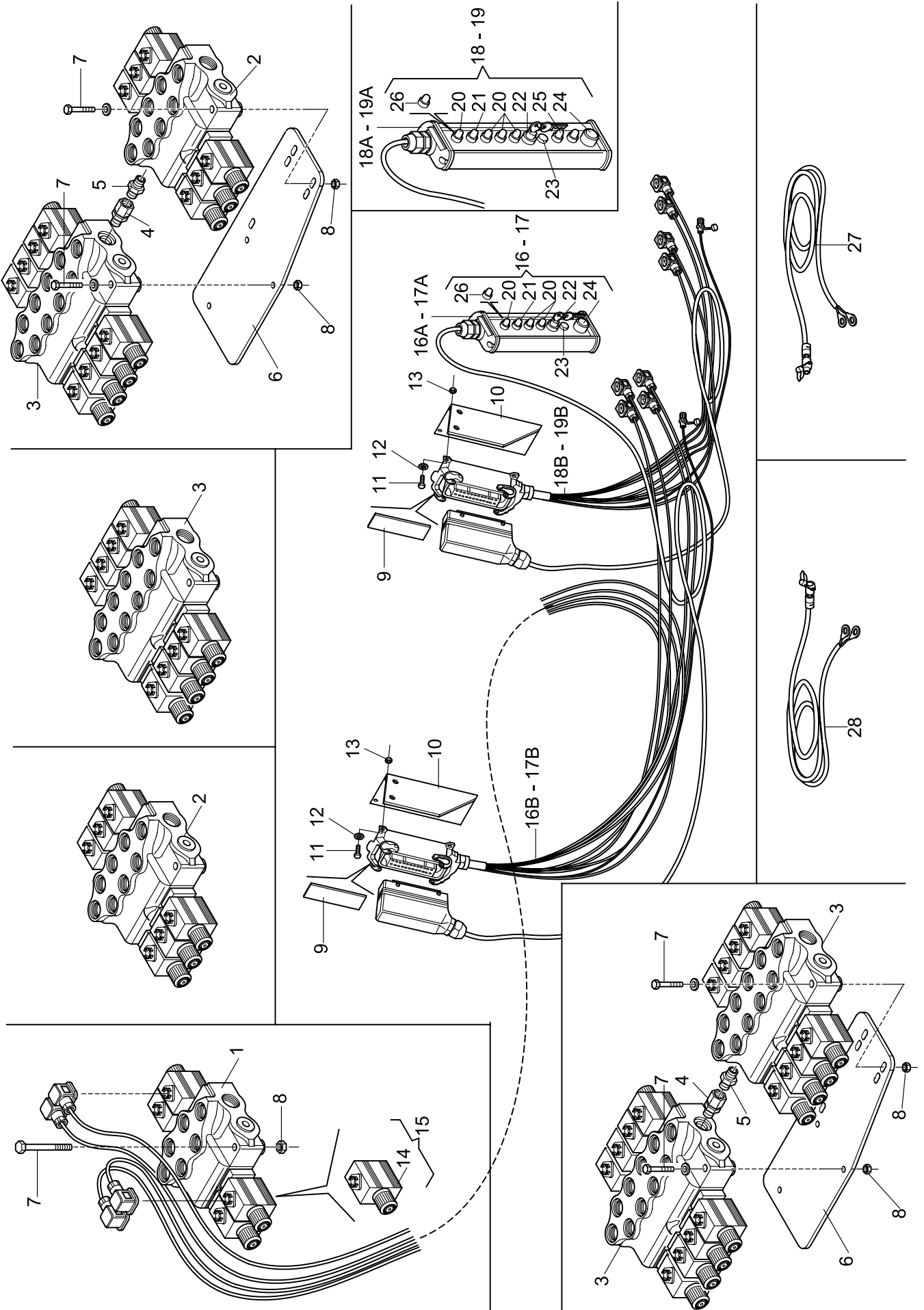

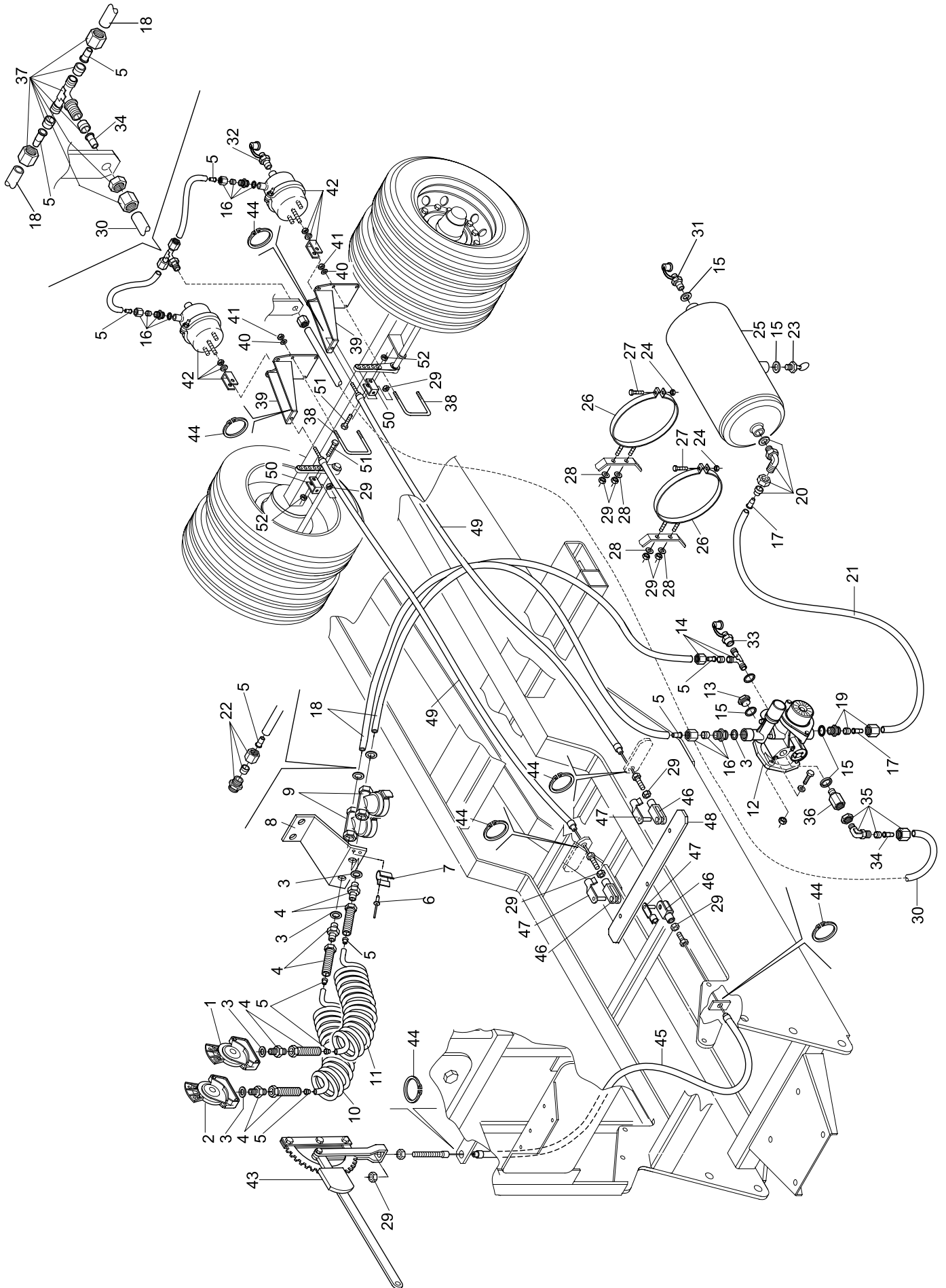

CLICK HERE TO **DOWNLOAD** THE COMPLETE MANUAL

- Thank you very much for reading the preview of the manual.
- You can download the complete manual from: www.heydownloads.com by clicking the link below



- Please note: If there is no response to CLICKING the link, please download this PDF first and then click on it.

CLICK HERE TO **DOWNLOAD** THE COMPLETE MANUAL