



PARTS MANUAL (ALL STANDARDS)

VERTICAL MAST

MODELS **SJ12** **SJ16**

160606AE April 2014

SKYJACK

CLICK HERE TO **DOWNLOAD** THE COMPLETE MANUAL

- Thank you very much for reading the preview of the manual.
- You can download the complete manual from: www.heydownloads.com by clicking the link below



- Please note: If there is no response to CLICKING the link, please download this PDF first and then click on it.

CLICK HERE TO **DOWNLOAD** THE COMPLETE MANUAL

1.3 Upper Platform Assembly

Index No.	Skyjack Part No.	Qty.	Description
			NOTE: Part Numbers followed by a "DG" indicate dark grey painted parts.
A	158110	1	UPPER PLATFORM ASSEMBLY (16 in. extension) (CE, AS & KC)
B	158138	1	UPPER PLATFORM ASSEMBLY (20 in. extension) (ANSI/CSA)
1	157341	1	• WELDMENT, Platform
-	151668	1	• SERVICE LOCK ASSEMBLY, A
-	151672	1	• SERVICE LOCK ASSEMBLY, B
2	151623	1	• • ROD, A
	151621	1	• • ROD, B
3	151620	1	• • STRIKER
4	103984	3	• • NUT, Hex nylon lock (5/16"-18, Grade 5)
5	103882	1	• • BOLT, Hex head (5/16"-18 x 4", Grade 5)
6	156551	1	• • SPRING
7	151619	1	• • HANDLE
8	111804	1	• • BOLT, Carriage (3/8"-16 x 1", Grade 5)
9	103468	1	• • WASHER, Flat (1/2" SAE AA)
10	151618	1	• • MOUNT
11	110814	2	• • BOLT, Carriage (5/16"-18 x 3/4", Grade 5)
12	104606	1	• • NUT, Hex nylon lock (3/8"-16, Grade 5)
13	120094	2	• SCREW, Round head (10-32 x 0.625")
14	104003	2	• NUT, Hex head (10-32)
15	110853	2	• SCREW, Flat head cap (1/4"-20 x 5/8", Grade 5)
16	151650	2	• RETAINER, Washer
17	151677	2	• ROLLER (2.75" OD x 7/8" ID x 1.051")
18	116621	4	• SHIM (0.063")
19	131953	2	• WASHER, Flat (7/8")
20	103984	8	• NUT, Hex nylon lock (5/16"-18, Grade 5)
21	127437	8	• BOLT, Carriage (5/16"-18 x 2", Grade 5)
-	151563	1	• FOOT PEDAL ASSEMBLY
22	158370	1	• • WELDMENT, Foot pedal
23	158100	1	• • SPRING
24	103887	1	• • BOLT, Hex head (5/16"-18 x 3/4", Grade 5)
25	103996	2	• • WASHER, Flat (5/16")
26	103984	1	• • NUT, Hex head lock (5/16"-18, Grade 5)
27	157441	1	• • PIN, Clevis (1/2" x 3.5")
28	157467	1	• • PIN, Cotter
29	103468	2	• • WASHER, Flat (1/2")
30	151525	1	• • BASE, Foot pedal

1.9 Platform Limit Switch Assembly

Index No.	Skyjack Part No.	Qty.	Description
A	-	-	<p>NOTE: Part Numbers followed by a “DG” indicate dark grey painted parts.</p> <p>PLATFORM LIMIT SWITCH ASSEMBLY (ANSI/CSA, 20” traversing platform)</p>
B	-	-	<p>PLATFORM LIMIT SWITCH ASSEMBLY (CE/AS/KC, 16” traversing platform)</p>
1	156497	1	<ul style="list-style-type: none"> • BLOCK, Mounting, A
2	156497	2	<ul style="list-style-type: none"> • BLOCK, Mounting, B
2	103957	2	<ul style="list-style-type: none"> • SCREW, Round head machine (#8-32 x 1/2”), A
3	112249	2	<ul style="list-style-type: none"> • SCREW, Round head machine (#8-32 x 1/2”), B
3	112249	2	<ul style="list-style-type: none"> • WASHER, Lock (#8), A
4	103991	2	<ul style="list-style-type: none"> • WASHER, Lock (#8), B
4	103991	2	<ul style="list-style-type: none"> • WASHER, Flat (#8), A
5	116192	2	<ul style="list-style-type: none"> • WASHER, Flat (#8), B
5	116192	2	<ul style="list-style-type: none"> • SCREW, Round head machine (#8-32 x 5/8”), A
6	156522	1	<ul style="list-style-type: none"> • SCREW, Round head machine (#8-32 x 5/8”), B
6	156522	1	<ul style="list-style-type: none"> • LIMIT SWITCH ASSEMBLY, B
7	156523	1	<ul style="list-style-type: none"> • LIMIT SWITCH ASSEMBLY, A, B
8	108791	4	<ul style="list-style-type: none"> • CORD CLIP, Adhesive back

Index No.	Skyjack Part No.	Qty.	Description
-	158959DG	-	<p>NOTE: Part Numbers followed by a "DG" indicate dark grey painted parts.</p> <p>MAST 4 ASSEMBLY</p>
1	157909DG	1	<ul style="list-style-type: none"> • WELDMENT, Mast 4
2	103855	4	<ul style="list-style-type: none"> • BOLT, Hex head (1/4"-20 x 1/2", Grade 5)
3	103995	4	<ul style="list-style-type: none"> • WASHER, Flat (1/4")
4	157915DG	1	<ul style="list-style-type: none"> • COVER, Mast
5	149496	4	<ul style="list-style-type: none"> • NUT, Speed clip (1/4-20 x 1/2")
6	928533	1	<ul style="list-style-type: none"> • HANDLE
7	157822	2	<ul style="list-style-type: none"> • SCREW, Socket head cap (zinc, 5/16"-18 x 7/8")
8	117293	1	<ul style="list-style-type: none"> • BOX, Manual
9	156837	4	<ul style="list-style-type: none"> • SHIM, Platform MT 22GA (0.0299)
10	104694	4	<ul style="list-style-type: none"> • WASHER, Flat (#10)
11	158488	8	<ul style="list-style-type: none"> • BOLT, Hex head (3/8"-16 x 3/4", Grade 8)
12	125959	8	<ul style="list-style-type: none"> • WASHER, Flat hardened (3/8")
13	157763	2	<ul style="list-style-type: none"> • WEAR PAD (Thin & short)
14	158086	2	<ul style="list-style-type: none"> • WEAR PAD (Thick & long)
15	157759	8	<ul style="list-style-type: none"> • RIVET, Pop (3/16" x 0.25-0.375 GR)
16	158317	4	<ul style="list-style-type: none"> • SCREW, Thread rolling (10-32 x 3/8")
-	158964	1	<ul style="list-style-type: none"> • CHAIN TENSIONER ASSEMBLY, Mast 4
17	157709	1	<ul style="list-style-type: none"> • • MOUNT - Tensioner
18	158965	1	<ul style="list-style-type: none"> • • BLOCK, Tensioner
19	157711	1	<ul style="list-style-type: none"> • • PIN, Clevis
20	158963	1	<ul style="list-style-type: none"> • • PIN, Chain (BL 434)
21	157825	2	<ul style="list-style-type: none"> • • PIN, Spring (0.156 x 1/2")
22	158320	4	<ul style="list-style-type: none"> • • BOLT, Hex head (5/16"-18 x 3/4", Grade 8)
23	103996	4	<ul style="list-style-type: none"> • • WASHER, Flat (5/16")
24	157467	1	<ul style="list-style-type: none"> • • PIN, Cotter

Index No.	Skyjack Part No.	Qty.	Description
-	157667DG	-	<p>NOTE: Part Numbers followed by a "DG" indicate dark grey painted parts.</p> <p>MAST 1 ASSEMBLY</p>
1	157668DG	1	<ul style="list-style-type: none"> • WELDMENT, Mast 1
2	159398	2	<ul style="list-style-type: none"> • WEAR PAD (Thin & long)
3	157759	8	<ul style="list-style-type: none"> • RIVET, Pop (3/16" x 0.25-.375 GR)
4	157797DG	1	<ul style="list-style-type: none"> • SUPPORT, Limit switch
5	157829	2	<ul style="list-style-type: none"> • SCREW, Socket head cap (#10-32 x 3/8")
6	158087	2	<ul style="list-style-type: none"> • WEAR PAD (Thick & short)
7	101297	6	<ul style="list-style-type: none"> • BOLT, Hex head (3/8"-16 x 1.25", Grade 5)
8	103999	8	<ul style="list-style-type: none"> • WASHER, Lock (3/8")
9	125959	8	<ul style="list-style-type: none"> • WASHER, Flat hardened (3/8")
10	103870	2	<ul style="list-style-type: none"> • BOLT, Hex head (3/8"-16 x 1.5", Grade 5)
-	157670	1	<ul style="list-style-type: none"> • CHAIN TENSIONER ASSEMBLY
11	157671	1	<ul style="list-style-type: none"> • • BLOCK, Tensioner mount (Mast 1)
12	157265	1	<ul style="list-style-type: none"> • • PIN, Clevis
13	157672	1	<ul style="list-style-type: none"> • • BLOCK, Tensioner (Mast 1)
14	157673	2	<ul style="list-style-type: none"> • • PIN, Chain (BL 444)
15	157033	4	<ul style="list-style-type: none"> • • PIN, Spring (0.156 x 5/8")
16	157467	1	<ul style="list-style-type: none"> • • PIN, Cotter
17	158319	6	<ul style="list-style-type: none"> • • BOLT, Hex head (5/16"-18 x 1.0", Grade 8)
18	103996	6	<ul style="list-style-type: none"> • • WASHER, Flat (5/16")

CLICK HERE TO **DOWNLOAD** THE COMPLETE MANUAL

- Thank you very much for reading the preview of the manual.
- You can download the complete manual from: www.heydownloads.com by clicking the link below



- Please note: If there is no response to CLICKING the link, please download this PDF first and then click on it.

CLICK HERE TO **DOWNLOAD** THE COMPLETE MANUAL

3.6 Chain Assembly (SJ16)

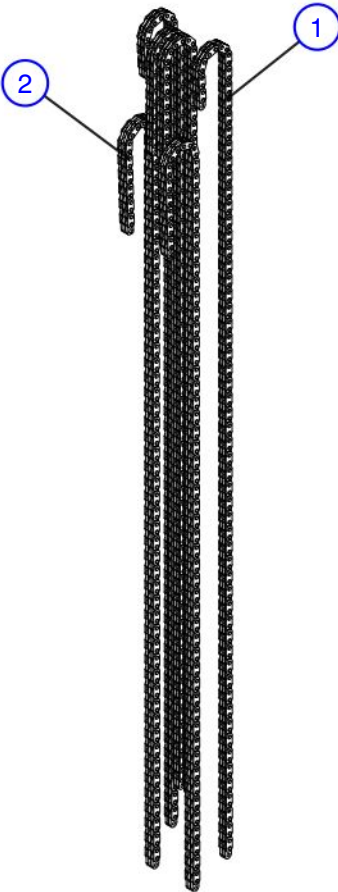

M158107AB

Index No.	Skyjack Part No.	Qty.	Description
-	158107	1	<p>NOTE: Part Numbers followed by a "DG" indicate dark grey painted parts.</p> <p>CHAIN ASSEMBLY</p>
1	157721	4	<ul style="list-style-type: none"> • CHAIN - BL 434
2	158462	2	<ul style="list-style-type: none"> • CHAIN - BL 444

Index No.	Skyjack Part No.	Qty.	Description
			NOTE: Part Numbers followed by a "DG" indicate dark grey painted parts.
A	158350DG	-	BASE ASSEMBLY (SJ12)
B	157134DG	-	BASE ASSEMBLY (SJ16)
1	158351DG	1	• WELDMENT, Base, A
	157411DG	1	• WELDMENT, Base, B
2	100904	4	• BUSHING, Fiberglide (1.5" ID x 1")
3	149782	2	• WASHER, Bronze (kingpin)
4	156848	4	• D-RING ASSEMBLY
5	101297	8	• BOLT, Carriage (3/8"-16 x 1.25", Grade 5), A
	117430	8	• BOLT, Carriage (3/8"-16 x 1.25", Grade 8), B
6	104606	8	• NUT, Hex nylon lock (3/8"-16, Grade 5)
7	103472	18	• WASHER, Flat (3/8"), A
	103472	17	• WASHER, Flat (3/8"), B
8	115420	1	• STRAP, Static
9	103473	1	• BOLT, Hex head (3/8"-16 x 1", Grade 5)
10	155979	1	• WASHER, Int tooth lock (3/8")
11	108575	1	• NUT, Hex head jam (3/8"-16, Grade 5)
12	157157DG	1	• PLATE, Hinged
13	139641	2	• RIVET, Pop (1/4")
14	151659DG	1	• BRACKET, Latch weld
15	103995	2	• WASHER, Flat (1/4")
16	104000	2	• WASHER, Lock (1/4")
17	103856	2	• BOLT, Hex head (1/4"-20 x 3/4", Grade 5)
18	158812DG	1	BRACKET WELDMENT, Main Valve
	158813DG	1	• BRACKET, Main valve
	138624	2	• WELD NUT, Pilot projection (.31-18)
19	(Ref.)	1	HOLDER, Rubber (For components, refer to Section 4.1)

Index No.	Skyjack Part No.	Qty.	Description
			NOTE: Part Numbers followed by a "DG" indicate dark grey painted parts.
A	158149DG	-	DRIVE/STEER ASSEMBLY (ANSI/CSA)
B	158316DG	-	DRIVE/STEER ASSEMBLY (CE/AS/KC)
1	107912	4	• HUB, Wheel
2	103199	20	• BOLT, Wheel (1/2"-20 x 1.5625")
3	151246DG	1	• WELDMENT, Motor (Right-hand)
4	151326	2	• PIN, Steer
5	151650	2	• RETAINER, Washer
6	110853	4	• SCREW, Flat head cap (1/4"-20 x 5/8", Grade 5)
7	100050	2	• BUSHING, Fibreglide
8	151260DG	1	• WELDMENT, Steer arm (Left-hand)
9	107951	2	• SCREW, Hex socket shoulder (5/8" x 1.25")
10	107949	2	• NUT, Hex head jam (1/2"-13, Grade 5)
11	107143	2	• END, Rod
12	106450	2	• NUT, Hex head jam (3/4"-16, Grade 5)
13	(Ref.)	1	• CYLINDER, Steer (For components, refer to Section 4.9)
14	103789	2	• WASHER, Int tooth lock (1")
15	107947	2	• NUT, Hex head jam (1"-14, Grade 5)
16	151259DG	1	• WELDMENT, Steer arm (Right hand)
17	151247DG	1	• WELDMENT, Motor (Left hand)
18	132565	2	• CAP, Grease (GC5)\
19	(Ref.)	1	• WHEEL MOTOR AND BRAKE ASSEMBLY (For components, refer to Section 4.10)
20	(Ref.)	1	• POWERPACK ASSEMBLY (For components, refer to Section 4.11)

Index No.	Skyjack Part No.	Qty.	Description
			NOTE: Part Numbers followed by a "DG" indicate dark grey painted parts.
A	158744DG	-	BASE CONTROL CENTRE ASSEMBLY (ANSI/CSA, KC)
B	158746DG	-	BASE CONTROL CENTRE ASSEMBLY (CE)
C	158739DG	-	BASE CONTROL CENTRE ASSEMBLY (AS)
1	158418DG	1	• LOWER CONTROLS, A, C
	158419DG	1	• LOWER CONTROLS, B
	158420DG	1	• • WELDMENT, Controls face
2	147069	1	• • HEAD, Selector switch (Lower/Raise)
3	149536	1	• • HEAD, Selector key switch (Off/Platform/Base), A, C
	147057	1	• • HEAD, Selector key switch (Off/Platform/Base), B
4	147051	1	• • HEAD, Emergency stop
5	158728	1	• LOWER CONTROL BOX ASSEMBLY
	151551	1	• • WELDMENT, Controls deck
6	103962	10	• • SCREW, Round head machine (#10-32 x 1/2")
7	108589	8	• • RELAY, Sealed (24V)
8	104694	10	• • WASHER, Flat (#10)
9	104185	10	• • WASHER, Lock (#10)
10	104003	10	• • NUT, Hex head (#10-32)
11	103057	1	• • BEEPER, Slow pulsing (24VDC)
12	(Ref.)	-	• • TERMINAL STRIP ASSEMBLY (For components, refer to Section 4.16)
13	-	-	• • SWITCH, Selector (Lower/Raise)
	147056	1	• • • LATCH
	147054	2	• • • BLOCK, Contact (N.O.)
14	-	-	• • SWITCH, Selector key (Off/Platform/Base)
	147056	1	• • • LATCH
	147054	1	• • • BLOCK, Contact (N.O.)
	147053	2	• • • BLOCK, Contact (N.C.)
15	-	-	• • SWITCH, Emergency stop
	147056	1	• • • LATCH
	147053	1	• • • BLOCK, Contact (N.C.)
	147061	1	• • • LED BLOCK, 24V (Red)
16	151551DG	1	• • WELDMENT, Controls deck
17	(Ref.)	1	• • HARNESS, Main (For components, refer to Section 4.18)
18	103964	8	• SCREW, Round head machine (#10-32 x 1/4")
19	151558DG	1	• COVER, Lower controls

Index No.	Skyjack Part No.	Qty.	Description
			NOTE: Part Numbers followed by a "DG" indicate dark grey painted parts.
A	158342	-	PIPE RACK KIT (ANSI/CSA)
B	158804	-	PIPE RACK KIT (CE)
C	158848	-	PIPE RACK KIT (AS/KC)
-	157408	1	• ASSEMBLY, Pipe rack (Right side)
-	158343	1	• ASSEMBLY, Pipe rack (Left side)
1	157404	1	• • WELDMENT, Pipe rack (Right side)
2	158344	1	• • WELDMENT, Pipe rack (Left side)
3	158357	1	• • STRAP, Nylon tie down flat hook
4	158381	2	• • SPACER, Stand off (5/16" ID x 1" LG)
5	158380	2	• • BOLT, Carriage (5/16" - 18 x 1.75" grd5)
6	124548	1	• • LARGE LOOP PIN QUICK RELEASE ASSEMBLY
7	103995	1	• • WASHER, Flat (1/4")
8	157173	1	• • RIVET (1/4"x 0.49")
9	127437	3	• • BOLT, Carriage (5/16"-18 x 2", Grade 5)
10	103984	5	• • NUT, Hex nylon lock (5/16"-18, Grade 5)
11	157405	1	• • WELDMENT, Tube pipe rack
12	159707	1	• CERTIFICATE, Mini Lift Pipe Rack, (Not shown) B
13	159710	2	• LABEL, Attachment combo, vertical, B, C
14	158874	2	• LABEL, Pipe rack capacity
15	158872	2	• LABEL, Manual force (200N) / No wind (0 m/s), B, C
16	159281	1	• FIELD INSTRUCTION, Pipe Rack Installation (Not shown), A
	159614	1	• FIELD INSTRUCTION, Pipe Rack Installation (Not shown), B
	159617	1	• FIELD INSTRUCTION, Pipe Rack Installation (Not shown), C

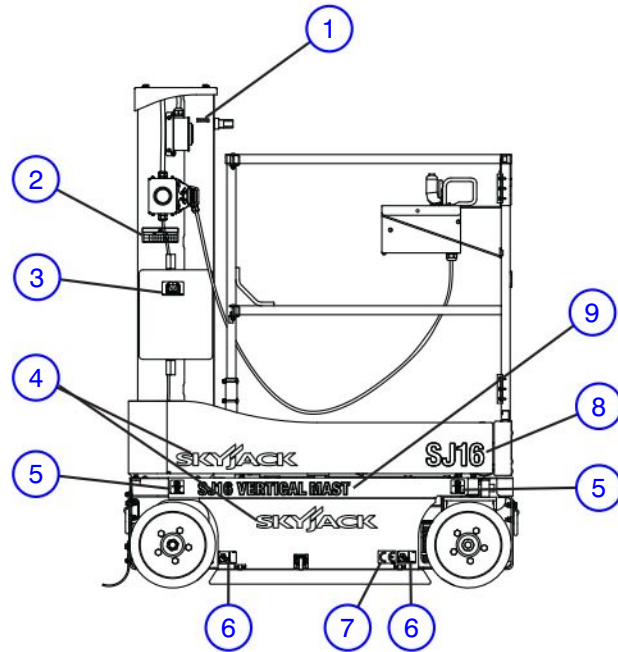

SJ16 Right View-2

Index No.	Skyjack Part No.	Qty.	Description
<p>NOTE: Part Numbers followed by a "DG" indicate dark grey painted parts.</p>			
1	138211	1	LABEL, Connect Platform AC Supply
2	156441	1	LABEL, Annual Inspection
3	123628	1	LABEL, Manual Storage Box
4	158536	2	LABEL, Skyjack Logo (White)
5	157014	2	LABEL, Wheel Load (400 kg/880 lb.) (SJ12) (Not included in kit)
	156602	2	LABEL, Wheel Load (475 kg/1050 lb.) (SJ16) (Not included in kit)
6	102896	2	LABEL, Forklift Pocket
7	117023	1	LABEL, "CE" (CE)
8	159517	1	LABEL, Model Number ("SJ12") (Not included in kit)
	159519	1	LABEL, Model Number ("SJ16") (Not included in kit)
9	159516	1	LABEL, Model Number ("SJ12 Vertical Mast") (Not included in kit)
	159518	1	LABEL, Model Number ("SJ16 Vertical Mast") (Not included in kit)

CLICK HERE TO **DOWNLOAD** THE COMPLETE MANUAL

- Thank you very much for reading the preview of the manual.
- You can download the complete manual from: www.heydownloads.com by clicking the link below



- Please note: If there is no response to CLICKING the link, please download this PDF first and then click on it.

CLICK HERE TO **DOWNLOAD** THE COMPLETE MANUAL