

Ⓓ **Ersatzteilliste**

Nr. 99 103.DE.90E.2

Ⓕ Catalogue des Pièces Detachees

ⒼⒷ Spare parts list

---

## **LADEPROFI II**

(Type 103 : + . . . 04429 - 04933)

## **LADEPROFI 2 Profimatic**

(Type 104 : + . . . 04934)



Ihre / Your / Votre • Masch.Nr. • Fgst.Ident.Nr.

Version **03/04**

CLICK HERE TO **DOWNLOAD** THE COMPLETE MANUAL

- Thank you very much for reading the preview of the manual.
- You can download the complete manual from: [www.heydownloads.com](http://www.heydownloads.com) by clicking the link below



- Please note: If there is no response to CLICKING the link, please download this PDF first and then click on it.

CLICK HERE TO **DOWNLOAD** THE COMPLETE MANUAL

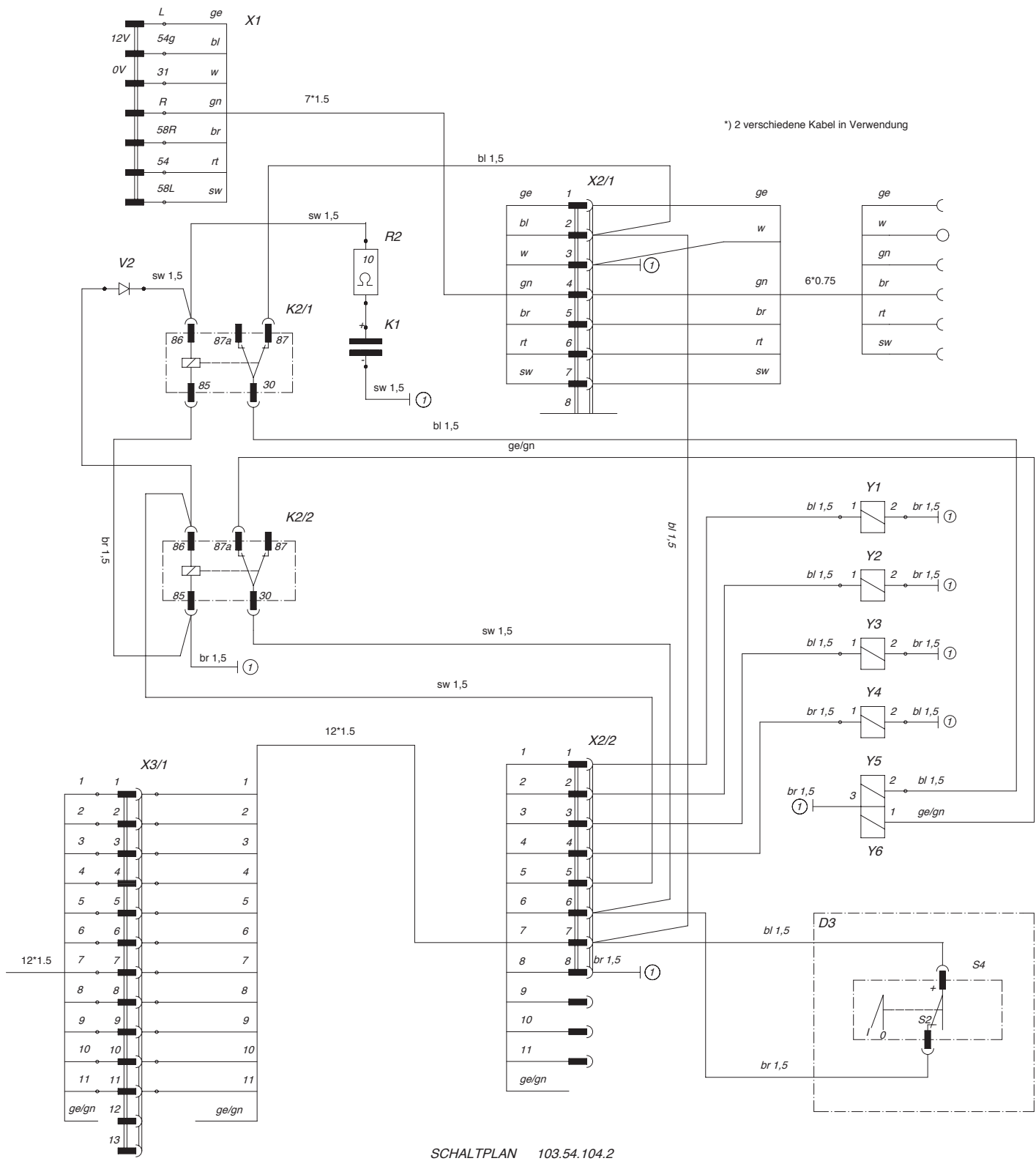

SCHALTPLAN 103.54.104.2

PNR	TEILE-NR	MENGE	BENENNUNG	DESIGNATION	DESCRIPTION	BEMERK/REMARQUE	FU
0.01	00 103.27.100.0	1	GANZSTAHLAUFBAU	RIDELLES	SUPERSTRUCTURE	(1-81	
1	00 108.20.101.0	1	FRONTGATTER	RIDELLE AVANT	FRONT GATE		
2	00 104.27.104.0	8	STEHER SZ	SUPPORT	UPRIGHT		
3	00 102.22.210.0	1	STEHER HI. LI.	SUPPORT	UPRIGHT	L	
4	00 102.22.215.0	1	STEHER HI. RE.	SUPPORT	UPRIGHT	R	
5	00 102.22.206.0	1	HECKWAND LI.	PORTE ARRIERE	PANEL	L	
6	00 102.22.205.0	1	HECKWAND RE.	PORTE ARRIERE	PANEL	R	
7	00 108.20.113.0	1	TRAEGER	SUPPORT	TRANSPORT BRACKET		
8	00 245.264.001	2	BORDWAND	RIDELLE LATERALE PL.	SIDE WALL		
9	00 245.263.001	2	BORDWAND	RIDELLE LATERALE PL.	SIDE WALL		
10	00 103.20.065.0	1	SEITENBLECH LI.	TOLE LATERALE	SIDE PLATE	L	
11	00 103.20.068.0	1	SEITENBLECH RE.	TOLE LATERALE	SIDE PLATE	R	
12	00 121.20.068.0	8	BEILAGE	CALE	WASHER		
13	00 122.058	18	SICHERUNGSMUTTER M12 DIN 980-8	ECROU „STOVER“	LOCK NUT		
14	00 100.087	20	SK-SCHR. M12X35 DIN 933 8,8	VIS A TET 6 PANS	SCREW, HEX.HD.		
15	00 153.59.017.0	2	SCHARNIERHUELSE	GARNITURE-CHARNIERE	HINGE SLEEVE		
16	00 108.953	102	SCHRAUBE M.INNENSECHS.M8X20	VIS	SCREW		
17	00 122.106	102	SI-MUTTER M8 DIN 980-8	ECROU M8 DIN 980	NUT M8 DIN 980		
18	00 162.407	102	SCHIBE 18X8,5X2	RONDELLE	WASHER		
19	00 103.065	30	SK-SCHR. M10X30 DIN 933-8.8 ZN	VIS M10X30	SCREW M10X30		
20	00 165.311	96	FEDERRING 10 DIN 128 ZN	RONDELLE 10 DIN 128	WASHER 10 DIN 128 ZN		
21	00 120.160	96	SK-MUTTER M10 DIN 934-8 ZN	ECROU M10 DIN 934-8	NUT M10 DIN 934-8		
22	00 103.043	7	SK-SCHR. M8X20 DIN 933-8.8 ZN	VIS M8X20	SCREW M8X20		
23	00 162.402	7	SCHIBE 24X8,5X1,5	RONDELLE	WASHER		
24	00 122.106	7	SI-MUTTER M8 DIN 980-8	ECROU M8 DIN 980	NUT M8 DIN 980		
25	00 108.23.005.0	1	KLAPPWAND VORNE SCHW.ZUS.	CONSOLE	CONSOLE		
26	00 108.23.013.0	2	FORMROHR	TUBE FACONNE	SUPPORT		
27	00 108.23.009.0	1	SEITENBLECH VO.LI.	TOLE LATERALE	SIDE PLATE	L	
28	00 108.23.010.0	1	SEITENBLECH VO.RE.	TOLE LATERALE	SIDE PLATE	R	
29	00 108.23.011.0	1	SEITENBLECH HI.LI.	TOLE LATERALE	SIDE PLATE	L	
30	00 108.23.012.0	1	SEITENBLECH HI.RE.	TOLE LATERALE	SIDE PLATE	R	
33	00 102.23.132.0	1	KONSOLE I	CONSOLE	BRACKET		
34	00 102.23.133.0	1	KONSOLE II SCHW.ZUS.	CONSOLE	BRACKET		
35	00 102.23.119.0	2	WINKEL	CORNIERE	ANGLE		
36	00 108.23.015.0	1	WINKEL VO.LI.	CORNIERE	ANGLE	L	
37	00 108.23.016.0	1	WINKEL VO.RE.	CORNIERE	ANGLE	R	
38	00 108.23.017.0	1	WINKEL MI.LI.	CORNIERE	ANGLE	L	
39	00 108.23.018.0	1	WINKEL MI.RE.	CORNIERE	ANGLE	R	
40	00 108.23.019.0	1	WINKEL HI.LI.	CORNIERE	ANGLE	L	
41	00 108.23.020.0	1	WINKEL HI.RE.	CORNIERE	ANGLE	R	
42	00 102.23.120.0	10	SCHARNIER ZUS.	CHARNIERE	HINGE		
43	00 103.064	38	SK-SCHR. M10X25 DIN 933-8.8 ZN	VIS M10X25	SCREW M10X25		
44	00 108.23.014.0	8	C-PROFIL	PROFILE	SECTION		
45	00 104.27.115.0	1	BUEGEL HINTEN S.Z.	ETRIER	CROSSTIE		
46	00 103.27.110.0	2	ABSCHLUSSLEISTE SCHW.ZUS.	LISTEAU/MOULURE	STRIP		
47	00 103.305	24	SK-SCHR. M10X70 DIN 931-8.8 ZN	VIS M10X70 DIN 931	SCREW M10X70 DIN 931		
48	00 102.22.156.0	2	LASCHE	ECLISSE	PLATE		
49	00 162.401	2	SCHIBE 26X16,1X1	RONDELLE	WASHER		
50	00 172.081	2	SPANNSTIFT 4X30 DIN 1481	GOUPILLE MECANINDUS	ROLLPIN		
51	00 122.107	2	SI-MUTTER M10 DIN 980-8	ECROU M10 DIN 980	NUT M10 DIN 980		
52	00 103.308	2	SK-SCHR. M10X85 DIN931, 8.8 ZN	VIS M10X85	SCREW M10X85		
53	00 102.22.223.0	2	HAKEN	CROCHET	LOCK		
54	00 435.664	2	TELLERFEDER	RONDELLE BELLEVILLE	DISC SPRING		
55	00 162.404	12	SCHIBE 20X10,5X1,5 ZN	RONDELLE	WASHER		
56	00 438.052	2	KLAPPVORSTECKER 9,5 MM ZN M.	GOUPILLE FENDUE	PIN LINCIN		
57	00 103.107	2	SK-SCHR. M 14X30 DIN 933-8.8	VIS HEXAGONAL	SCREW, HEX.HD.		
58	00 122.109	2	SICHERUNGSMUTTER M14 DIN 980-8	ECROU „STOVER“	LOCK NUT		
59	00 102.20.041.0	2	BEILAGE	CALE	WASHER		
60	00 100.085	2	SK-SCHRAUBE M12X25 DIN 933-8.8	VIS	SCREW		
61	00 118.111	12	BOHR-SCHRAUBE 5,5X16	VIS 5,5X16	SCREW 5,5X16		
62	00 101.20.012.0	2	KABELFUEHRUNG	GUIDAGE PAR CABLE	GUIDE		
63	00 158.64.003.0	1	KABELFUEHRUNG	GUIDAGE PAR CABLE	GUIDE		
64	00 102.20.149.0	1	KABELFUEHRUNG	GUIDAGE PAR CABLE	GUIDE		
65	00 430.205	18	TREVIRASEIL WEISS 6X6400	CORDE EN TREVIRA	TREVIRA ROPE		
66	00 103.27.104.0	1	OELLEITUNG	CONDUITE D'HUILE	OIL LINE	(66,80,81	
67	00 447.4.252	1	HYDRAULIKSCHLAUCH NW6/5000	TUYAU HYDRAULIQUE	HYDRAULIC HOSE	L=5000MM	
68	00 245.264.002	2	BORDWAND	RIDELLE LATERALE PL.	SIDE WALL		
69	00 245.263.002	2	BORDWAND	RIDELLE LATERALE PL.	SIDE WALL		
80	00 448.005	2	UEBERWURFMUTTER AL 8 DIN 3870	ECROU-CHAPEAU	NUT		
81	00 448.006	2	SCHNEIDRING L 8 DIN 3861	FILIERE	RING		

PNR	TEILE-NR	MENGE	BENENNUNG	DESIGNATION	DESCRIPTION	BEMERK/REMARQUE	FU
0.01	00	103.22.025.1	1 RUECKWANDAUSHEBUNG	LEVEE DE PAROI ARRI.	REAR WALL LEVY	(1-56	
1	00	104.20.119.0	2 LASCHE	ECLISSE	PLATE		
2	00	104.20.092.0	2 STREBE	JAMBE DE FORCE	STRUT		
3	00	104.20.115.1	2 HEBEL LI.SZ.	LEVIER GAUCHE	LEVER LEFT	L	
4	00	104.22.010.1	2 GEWINDEBOLZEN	BOULON FILETE	BOLT		
5	00	104.20.087.1	1 HEBEL LI.SZ.	LEVIER GAUCHE	LEVER LEFT	R	
6	00	104.20.095.0	1 KONSOLE LI.	CONSOLE	BRACKET	L	
7	00	490.507	4 GABELKOPF G 12X24 DIN 71752	CHAPE	FORK-TOP		
8	00	104.20.086.0	2 STANGE	TIGE	ROD		
10	00	157.010	2 SICHERUNGSRING	SEGMENT D'ARRET	CIRCLIP		
11	00	162.416	4 SCHEIBE 24X13X2	RONDELLE	WASHER		
12	00	162.417	14 SCHEIBE 36X20,5X2	RONDELLE	WASHER		
13	00	157.018	2 SICHERUNGSRING 20X1,2 DIN 471	SEGMENT D'ARRET	CIRCLIP		
14	00	172.964	10 SPANNSTIFT 5X30 DIN 1481	GOUPILLE MECANINDUS	ROLLPIN		
15	00	442.071	2 HYDRAULIKZYLINDER	CYLINDRE D'HYDR.	HYDRAULIC CYLINDER		
15.01	00	442.110	2 DICHTUNGSSATZ ( BUETER )	GARNITURE DE JOINTS	SET OF GASKETS		
16	00	501.20.008.0	2 LASCHE	ECLISSE	PLATE		
17	00	162.402	4 SCHEIBE 24X8,5X1,5	RONDELLE	WASHER		
18	00	122.106	12 SI-MUTTER M8 DIN 980-8	ECROU M8 DIN 980	NUT M8 DIN 980		
19	00	103.044	6 SK-SCHR. M 8X25 DIN 933-8.8	VIS M 8X25	SCREW M 8X25		
20	00	104.20.128.0	1 HEBEL RE.SZ.	LEVIER	LEVER		
21	00	120.159	2 SK-MUTTER M8 DIN 934-8 ZN	ECROU M8 DIN 934	NUT M8 DIN 934		
22	00	103.048	2 SK-SCHR. M 8X45 DIN 933-8.8	VIS M 8X45	SCREW M 8X45		
23	00	120.163	4 SK-MUTTER M16 DIN 934-8 ZN	ECROU M16	NUT M16		
24	00	435.389	2 ZUGFEDER 14/71X520 ZN	RESSORT DE TRACTION	SPRING		
25	00	104.20.084.1	2 BOLZEN	AXE	PIN		
26	00	435.150	2 DRUCKFEDER	RESSORT DE PRESSION	SPRING		
27	00	173.081	2 SPANNSTIFT 4X30 DIN 1481	GOUPILLE	ROLLPIN		
28	00	162.422	8 SCHEIBE 26X16,2X2	RONDELLE	WASHER		
29	00	104.20.085.0	2 BOLZEN	AXE	PIN	-4933	
29.01	00	141.22.174.1	2 BOLZEN	AXE	PIN	+4934	
30	00	410.616	4 GLACIER-BUECHSE PM 2015 DX	DOUILLE GLACEE	BUSH		
31	00	103.290	6 SK-SCHR. M 8X75 DIN 931-8.8	VIS HEXAGONAL	SCREW, HEX.HD.		
32	00	435.652	4 TELLERFEDER	RONDELLE BELLEVILLE	DISC SPRING		
33	00	448.1.051	2 REDUZIERSTUTZEN	REDUCTION RACCORD	REDUCTION SOCKET		
34	00	447.2.202	2 HYDR.SCHLAUCH NW6 L=1200	TUYAU L=1200	TUBE L=1200		
35	00	448.706	2 BEFESTIGUNSSCHELLE	COLIER	CLIP		
36	00	118.111	2 BOHR-SCHRAUBE 5,5X16	VIS 5,5X16	SCREW 5,5X16		
37	00	448.1.101	1 WINKELVERSCHRAUBUNG	RACCORD FILETE COUDE	CONNECTING SCREW		
38	00	448.701	2 BEFESTIGUNSSCHELLE	COLLIER	CLIP		
39	00	110.102	2 SK-HOLZSCHRAUBE M6X25 DIN571	VIS A BOIS HEXAGONAL	WOOD-SCREW		
40	00	448.1.302	1 SCHOTTVERSCHRAUBUNG, GERADE	RACCORD VISSE	CONNECTING SCREW		
41	00	104.22.017.0	1 LEITUNG RE.	CONDUITE	OVERFLOW PIPE	(41, 45, 46 R	
42	00	448.1.251	1 T-VERSCHRAUBUNG	RACCORD FILETE EN T	T-CONNECTION		
43	00	459.101	2 KABELTUELLE 24X17X11X10	PASSE-FIL 24X17X11X10	GROMMET 24X17X11X10		
44	00	104.22.016.0	1 LEITUNG LI.	CONDUITE	OVERFLOW PIPE	(44-46 L	
45	00	448.005	6 UEBERWURFMUTTER AL 8 DIN 3870	ECROU-CHAPEAU	NUT		
46	00	448.006	6 SCHNEIDRING L 8 DIN 3861	FILIERE	RING		
47	00	103.22.013.0	1 LEITUNG	CONDUITE	OVERFLOW PIPE	(45-47	
48	00	447.4.203	2 SCHLAUCH L=4300	TUYAU SOUPLE	TUBE		
48.01	00	447.5.201	1 HYDRAULIKSCHLAUCH NW6/600	TUYAU HYDRAULIQUE	HYDRAULIC HOSE	(59	
49	00	104.22.019.0	1 DROSSEL	PAPILLON	THROTTLE		
50	00	104.20.091.1	1 HEBEL RE.SZ.	LEVIER DROITE	LEVER RIGHT	R	
51	00	104.20.097.0	1 KONSOLE RE.	CONSOLE	BRACKET	R	
52	00	120.161	2 SK-MUTTER M12 DIN 934-8 ZN	ECROU M12	NUT M12		
53	00	448.019	1 EINSTELLB. WINKELVERSCHRAUBUNG	RACCORD FILETE REGL.	CONNECTING SCREW		
54	00	448.098	1 REDUZIERSTUTZEN M14X1,5	REDUCTION RACCORD	REDUCTION SOCKET		
55	00	104.082	2 ZYL-SCHR. M12X25 DIN 912-8.8	VIS-CYLINDRIQUE	BOLT, SOCKET		
56	00	122.108	4 SI-MUTTER M12 DIN 980-8 ZN	ECROU M12 DIN 980-8	NUT M12 DIN 980-8		
57	00	494.440	1 AZB „RUECKWAND“	ETIQUETTE	DECAL		
58	00	104.20.129.0	2 WINKEL	CORNIERE	ANGLE		
59	00	415.579	4 O-RING 6.5X1.5	JOINT TORIQUE	O-RING		
60	00	447.4.257	1 SCHLAUCH L=4000	TUYAU SOUPLE	TUBE	(61	
61	00	415.577	2 O-RING 7,5X1,5	JOINT TORIQUE	O-RING		
62	00	103.088	2 SK-SCHR. M12X40 DIN 933-8.8	VIS M12X40	SCREW M12X40		

PNR	TEILE-NR	MENGE	BENENNUNG	DESIGNATION	DESCRIPTION	BEMERK/REMARQUE	FU
27.01	00 451.608	2	SCHEIBENRAD 9X15,3 ET+45	ROUE PLEINE	DISC-WHEEL	11,5/80-15	
27.02	00 451.618	2	FELGE 11X16 ET+45	JANTE DE ROUE	WHEEL RIM	13.0/55-17	
27.03	00 451.613	2	SCHEIBENRAD 13X17 ET+45	ROUE PLEINE	DISC-WHEEL	15/55-17	
27.04	00 451.625	2	SCHEIBENRAD 16,00X17 ETO	ROUE PLEINE	DISC-WHEEL	19.0/45-17	
27.05	00 451.535	4	SCHEIBENRAD 11X18 SUPER	ROUE PLEINE	DISC-WHEEL		
27.06	00 451.626	2	SCHEIBENRAD 16,00X17 ET - 35	ROUE PLEINE	DISC-WHEEL	ET-35	+4504
27.07	00 451.602	2	SCHEIBENRAD	ROUE PLEINE	DISC-WHEEL		
27.08	00 451.609	2	SCHEIBENRAD	ROUE PLEINE	DISC-WHEEL		
27.09	00 451.628	2	SCHEIBENRAD 16,0X17	ROUE PLEINE	DISC-WHEEL		
28	00 453.470	2	LAUFNABE F. UNGEBR. RAD	MOYEU	HUB	@1600	-5133
28.01	06 00240.2	2	RADNABE 6000 H	MOYEU DE ROUE	WHEEL HUB	+5134	
30	00 126.13.001.0	1	ACHSBRUECKE NORMAL	PONT D'ESSIEU	AXLE BRIDGE		
30.01	00 126.30.101.0	1	ACHSBRUECKE NIEDRIG	PONT D'ESSIEU	AXLE BRIDGE	#	
31	00 103.129	8	SK-SCHR. M16X40 DIN 933-8.8	VIS M16X40	SCREW M16X40		
32	00 162.409	8	SCHEIBE 34X16,5X3 ZN	RONDELLE	WASHER		
33	00 122.110	8	SI-MUTTER M16 DIN 980-8 ZN	ECROU M16 DIN 980	NUT M16 DIN 980		
37	00 126.13.007.0	2	DAEMPFUNGSLEISTE	PROTECTION	STRIP PLASTIC		
38	00 108.906	4	FLR-SCHRAUBE M8X50 DIN603-8.8	VIS A TETE BOMBEE	FLAT ROUND SCREW		
39	00 120.159	4	SK-MUTTER M8 DIN 934-8 ZN	ECROU M8 DIN 934	NUT M8 DIN 934		
40	00 190.002	2	SCHMIERNIPPEL A M8X1 DIN 71412	RACCORD DE GRAISSEUR	GREASING NIPPLE		
41	00 453.373	1	ACHSSTUMMEL F. UNGEBR. ACHSE	FUSEE D'ESSIEU	STUB AXLE	@1600	
42	00 453.255	2	HALTEBOLZEN BEWEGLICH	BOULON DE RETENUE	RETAINING BOLT		
43	00 -	0	--	--	--	*65, POS.27ET 0	
44	00 165.310	4	FEDERRING A 8 DIN 127	RONDELLE A 8 DIN 127	WASHER A 8 DIN 127		

4 FU4: (13.01,14.01,16.01,1-20  
4 FU4: (13.01,14.01,16.01,1-20  
4 FU4: (13.01,14.01,16.01,1-20

5 FU5: (13.02,14.02,16.02,1-20  
5 FU5: (13.02,14.02,16.02,1-20  
5 FU5: (13.02,14.02,16.02,1-20

PNR	TEILE-NR	MENGE	BENENNUNG	DESIGNATION	DESCRIPTION	BEMERK/REMARQUE	FU
0.01	00 103.06.000.0	1	KOTFLUEGEL	AILE A DEVANT	WINF FRONT	(1-10)	
1	00 103.06.005.0	2	KOTFLUEGEL	AILE A DEVANT	WINF FRONT		
2	00 459.884	4	GUMMIPLATTE 6X290X515	QUALITA PLAQUE DE CAOUTCHOUC	RUBBER PLATE		
3	00 153.06.027.0	4	FLACHEISEN	FER-PLAT	PLATE		
4	00 540.31.208.0	2	WINKEL	CORNIERE	ANGLE		
5	00 103.064	6	SK-SCHR. M10X25 DIN 933-8.8	ZN VIS M10X25	SCREW M10X25		
6	00 122.107	14	SI-MUTTER M10 DIN 980-8	ECROU M10 DIN 980	NUT M10 DIN 980		
7	00 162.404	14	SCHEIBE 20X10,5X1,5	ZN RONDELLE	WASHER		
8	00 103.066	8	SK-SCHR. M 10X35 DIN 933-8.8	VIS HEXAGONAL	SCREW, HEX.HD.		
9	00 118.009	4	SK-SCHRAUBE M8X16	VIS	SCREW		
10	00 139.31.007.0	8	LASCHE	ECLISSE	PLATE		

PNR	TEILE-NR	MENGE	BENENNUNG	DESIGNATION	DESCRIPTION	BEMERK/REMARQUE	FU
0.01	00	453.792	1 BREMSACHSE SPUR 1850	ESSIEU	AXLE		
1	07	0553151435	1 ACHSKOERPER	CORPS D'ESSIEU	AXLE MEMBER		
29	07	0337005140	2 STOSSRING 74/85X7	BAGUE	RING		
31	07	0326216110	2 KRONENMUTTER M36X1.5	ECROU CRÉNEAUX	CASTLE NUT		
32	07	0262016301	2 SPLINT 6.3X63	GOUILLE FENDUE	COTTERPIN		
33	07	0512026080	2 DICHTRING 73/110/14.5	BAGUE D'ETANCHEITE	SEAL RING		
34	07	0331023090	2 RING	BAGUE	RING		
36	07	0317714350	2 GEWINDEBOLZEN M24X1.5X36	BOULON M24X1.5X36	BOLT M24X1.5X36		
37	07	0254032490	2 FEDERSCHEIBE B24	RONDELLE B24	RING B24		
38	07	0252207582	2 SICHERUNGSMUTTER M24X1.5	ECROU „STOVER“	LOCK NUT		
40.01	07	0237045600	4 STOPFEN	BOUCHON	FITTING		
43	07	0509736495	2 BREMSNOCKENWELLE	ARBRE	SHAFT	L=593	
53	07	0331150130	2 RING	BAGUE	RING		
54	07	0256032990	2 SICHERUNGSRING	SEGMENT D'ARRET	CIRCLIP		
57	07	0539726030	2 ZUGFEDER	RESSORT DE TRACTION	SPRING		
59	07	0517465090	2 GESTAENGESTELLER	BOULON DE FREIN	BRAKE LEVER		
73	07	0509115210	4 BREMSBACKEN	MACHOIRE DE FREIN	BRAKE CHEEK		
79	07	0309219500	4 BREMSBELAG 15826/8	GARNITUR DE FREIN	BRAKE LINING		
80	07	0258056101	64 NIET 6X13	RIVET 6X13	RIVET 6X13		
82	07	0339732140	2 ZUGFEDER	RESSORT	TENSION SPRING		
82.01	07	0339744080	2 ZUGFEDER	RESSORT DE TRACTION	SPRING		
84	07	0327154020	2 NABE	MOYEU	HUB		
86	07	0310518010	2 BREMSTROMMEL	TAMBOUR DE FREIN	BRAKE DRUM		
91	07	0329670011	16 RADBOLZEN	BOULON DE ROUE	WHEEL BOLT		
93	07	0256152094	16 FEDERRING C20,5	RONDELLE GROWER	SPRING WASHER		
94	07	0252131483	16 FLACHBUNDMUTTER B20	ECROU	NUT		
95	07	0264047000	2 KEGELROLLENLAGER 32014X	ROULEM.A ROUL.CONI.	TAPER ROLLER BEARING		
96	07	0264015000	2 KEGELROLLENLAGER 30210	ROULEM.A ROUL.CONI.	TAPER ROLLER BEARING		
98	07	0321107030	2 KAPPE	CAPUCHON	CAP		

PNR	TEILE-NR	MENGE	BENENNUNG	DESIGNATION	DESCRIPTION	BEMERK/REMARQUE	FU
0.01	00 103.12.020.0	1	AUFLAUFBREMSZUG KPL.	CABLE DE FREIN A IN.	OVERRUN BRAKE CABLE	(1-24	
1	00 102.12.022.0	1	WIDERLAGER	BUTEE	NUT		
2	00 102.58.110.0	1	PLATTE	PLAQUE	BRACKET		
4	00 490.507	1	GABELKOPF G 12X24 DIN 71752	CHAPE	FORK-TOP		
5	00 103.311	4	SK-SCHRAUBE M10X100 DIN931-8.8	VIS	SCREW		
6	00 120.160	4	SK-MUTTER M10 DIN 934-8 ZN	ECROU M10 DIN 934-8	NUT M10 DIN 934-8		
7	00 165.311	4	FEDERRING 10 DIN 128 ZN	RONDELLE 10 DIN 128	WASHER 10 DIN 128 ZN		
14	00 102.12.017.0	1	BREMSSTANGE KURZ	TIGE DE COM.DU FREIN	ROD		
15	00 448.558	2	SCHLAUSCHELLE 19,0	BRIDE	CLAMP		
16	00 431.916	1	BREMSSEIL 1150 MM	CABLE DE FREIN	BRAKE CABLE		
17	00 103.088	3	SK-SCHR. M12X40 DIN 933-8.8	VIS M12X40	SCREW M12X40		
18	00 122.108	3	SI-MUTTER M12 DIN 980-8 ZN	ECROU M12 DIN 980-8	NUT M12 DIN 980-8		
19	00 120.161	3	SK-MUTTER M12 DIN 934-8 ZN	ECROU M12	NUT M12		
20	00 129.079	1	SPANNSCHLOSSMUTTER MB 12X125	ECROU DE TENDEUR	TURNBUCKLE		
21	00 128.107	1	SK-MUTTER M12 DIN 934-8	ECROU HEXAGONAL	NUT, HEX.	L	
22	00 102.12.025.1	1	SEILROLLE	POULIE GUIDE-CABLE	PULLEY		
23	00 433.161	1	BETAETIGUNG F.AUFLAUFBREMS.KPL	COMMANDE	CONTR.F. OVER.BRAKE		
24	00 103.041	1	SK-SCHRAUBE M8X16 DIN 933-8.8	VIS	SCREW		
25	00 122.106	1	SI-MUTTER M8 DIN 980-8	ECROU M8 DIN 980	NUT M8 DIN 980		
34	00 490.506	1	GABELKOPF G 12X48 DIN 71752	CHAPE	FORK-TOP		

PNR	TEILE-NR	MENGE	BENENNUNG	DESIGNATION	DESCRIPTION	BEMERK/REMARQUE	FU
70	00	454.364.015	2 GER. DURCHG. VERSCHR.	RACCORD VISSE	THREADED UNION		
71	00	454.364.007	2 WINKEL-EINSCHRAUBVERSCHR.	RACCORD VISSE	THREADED UNION		
72	00	454.382	1 DOPPELKUPPLUNGSKOPF	DOUB. EMBRAYAGE	COUPLING		
73	00	454.393	1 O-RING	JOINT TORIQUE	O-RING		
74	00	454.392	1 KONTERMUTTER M22X1,5	CONTRE ECROU	BACK NUT		
75	00	475.169	2 KABELBINDER 292X4,8	ATTACHE-CABLE	STRIP		
76	00	135.74.027.0	4 DISTANZBUECHSE	DOUILLE ENTRETOISE	SPACER		
77	00	103.090	4 SK-SCHR. M12X50 DIN 933-8.8 ZN	VIS M12X50	SCREW M12X50		
81	00	454.310	1 SCHLAUCHSTUTZEN	TUYAU DE RALLONGE	HOSE NOZZLE		
82	00	454.321	1 DICHRING 22X27	BAGUE D'ETANCHEITE	SEAL RING		
83	00	454.319	1 DRUCKRING 22X1,5	CONE DE SERRAGE	THRUST RING		
84	00	454.318	1 O-RING 22X1,5	JOINT TORIQUE	O-RING		
85	00	454.309	1 PRUEFANSCHLUSS	RACCORD DE CONTROLE	TEST COUPLING		
86	00	454.358	2 KOLBENZYLINDER 4"	PISTON CYLINDRE	PISTON CYLINDER		
87	00	153.02.010.0	4 DISTANZBUECHSE SZ.	DOUILLE ENTRETOISE	SPACER	P:40KM/H	
88	00	103.096	8 SK-SCHRAUBE M12X80	VIS	SCREW		
89	00	165.312	8 FEDERRING 12 DIN 128 ZN	RONDELLE 12 DIN 128	WASHER 12 DIN 128		
90	00	120.161	8 SK-MUTTER M12 DIN 934-8 ZN	ECROU M12	NUT M12		
91	00	454.317	1 UEBERWURFMUTTER	ECROU-CHAPEAU	NUT		
92	00	454.316	1 SCHLAUCHSTUTZEN	TUYAU DE RALLONGE	HOSE NOZZLE		
93	00	153.01.055.0	2 KONSOLE	CONSOLE	BRACKET		
94	00	450.22.044.0	8 DISTANZRING	BAGUE	RING	P:25KM/H	
95	00	454.301	1 KUPPLUNGSKOPF	TETE D'ACCOUPL.	COUPLING PART	# FU2	3
96	00	454.366	1 BREMSVENTIL MIT LOESEVENT.	REM. VALVE DE FREIN	TRAILER BRAKE VALVE	# FU2	3
97	00	454.391	1 SCHOTTSTUTZEN	RACCORD VISSE	THREADED UNION		

1 FU: (1-7,11,13-35,38-69  
1 FU: (1-7,11,13-35,38-69  
1 FU: (1-7,11,13-35,38-69

2 FU1: (8-10,12,13,24,25,29,30,36,37,47  
2 FU1: (8-10,12,13,24,25,29,30,36,37,47  
2 FU1: (8-10,12,13,24,25,29,30,36,37,47

3 FU2: P:EINLEITUNGSBREMSANLAGE  
3 FU2: P:PNEUMATIC BRAKES  
3 FU2: P:FREIN PNEUMATIQUE

4 FU3: (8.01-10,12,13,24,25,29,30,36,37,47  
4 FU3: (8.01-10,12,13,24,25,29,30,36,37,47  
4 FU3: (8.01-10,12,13,24,25,29,30,36,37,47

PNR	TEILE-NR	MENGE	BENENNUNG	DESIGNATION	DESCRIPTION	BEMERK/REMARQUE	FU
0.01	00 103.31.020.0	1	FESTSTELLBREMSE KPL.	FREIN D'ARRET	PARKING BRAKE	(1-7)	
1	00 103.31.021.0	1	FESTSTELLBREMSE SZ.	FREIN D'ARRET	PARKING BRAKE		
2	00 103.31.025.0	1	UMLENKROLLE SZ.	ROULEAU	ROLLER		
3	00 100.73.105.0	1	SEILROLLE	POULIE GUIDE-CABLE	PULLEY		
4	00 155.014	1	SICHERUNGSRING 16X1 DIN 471	SEGMENT D'ARRET	CIRCLIP		
5	00 431.610	1	DRAHTSEIL 6X1250	CABLE METALLIQUE	WIRE ROPE		
6	00 430.935	1	SEILKAUSCHE B6 DIN 6899	COSSE POUR CABLE	THIMBLE		
7	00 430.953	4	DRAHTSEILKLEMME 6,5 DIN 741	SERRE CABLE METAL.	WIRE CABLE CLAMP		

PNR	TEILE-NR	MENGE	BENENNUNG	DESIGNATION	DESCRIPTION	BEMERK/REMARQUE	FU
0.01	00 103.40.400.0	1	PRESSE ZUS.	PRESSE	PRESS	(1-55	
0.02	00 103.40.455.0	1	KURVENSCHLEIBE LI ZUS.	PLATEAU A CAME	CAMPLATE	(61,62 L	
0.03	00 103.40.465.0	1	KURVENSCHLEIBE RE. ZUS.	PLATEAU A CAME	CAMPLATE	(71,72 R	
3	00 121.80.035.0	1	STIRNRAD Z=40	ENGRENAGE	GEAR WHEEL CPTE.		
4	00 121.40.368.0	1	STELLRING	BAGUE DE REGLAGE	SET COLLAR		
5	00 121.80.039.0	1	HUELSE	DOUILLE	SLEEVE		
6	00 103.40.480.0	1	KETTENRAD Z=40 S.Z.	ROUE DE CHAINE	SPROCKET		
7	00 103.40.476.0	1	STELLRING	BAGUE DE REGLAGE	SET COLLAR		
8	00 103.40.477.0	1	BOLZEN RE.	AXE DROITE	PIN RIGHT		
9	00 103.40.510.0	1	PRESSENRAHMEN S.Z.	CHASSIS DE PRESSE	PRESS-FRAME		
10	00 103.40.490.0	14	ABSTREIFER S.Z.	RACLEUR	SCRAPER CPTE.		
12	00 103.40.496.0	1	ABSTREIFER S.Z.	RACLEUR	SCRAPER CPTE.		
13	00 103.40.497.0	2	ABSTREIFER SZ.	RACLEUR	SCRAPER CPTE.		
14	00 136.40.203.1	1	GLEITBLECH LI	TOLE GAUCHE	SLIDING PLATE LEFT	L	
15	00 136.40.204.1	1	GLEITBLECH RE	TOLE DROITE	SLIDING PLATE RIGHT	R	
16	00 102.40.106.0	6	BEILAGE DICK	CALE	WASHER		
17	00 102.40.107.0	4	BEILAGE DUENN	CALE	WASHER		
18	00 103.40.485.0	1	LASCHE S.Z.	ECLISSE	PLATE		
19	00 430.65.130.0	1	HUELSE	DOUILLE	SLEEVE		
20	00 103.40.308.0	1	ABDECKUNG	PANNEAU	COVER		
21	00 166.828	2	SCHLEIBE 75X55,5X2	RONDELLE	WASHER		
22	00 166.426	7	SCHLEIBE 75X55,5X1	RONDELLE	WASHER		
23	00 155.038	1	SICHERUNGSRING 55X2 DIN 471	SEGMENT D'ARRET	CIRCLIP		
24	00 150.687	1	PASSFEDER B 16X10X36 DIN 6885	CLAVETTE	KEY		
25	00 191.002	2	SCHMIERN. SFG AM 8X1 DIN 71412	RACCORD DE GRAISSAGE	GREASING NIPPLE		
26	00 174.634	4	GEWINDESTIFT M8X12 DIN916-10.9	CLAVETTE FILETEE	LOCKING RING		
27	00 166.845	5	SCHLEIBE 70D12X90X1 FEDERSTAHL	RONDELLE	WASHER		
28	00 166.233	3	SCHLEIBE 85X70,2X0,5	RONDELLE	WASHER		
29	00 155.046	1	SICHERUNGSRING 70 DIN 471	SEGMENT D'ARRET	CIRCLIP		
30	00 172.172	1	SPANNSTIFT 8X50 DIN 1481	GOUPILLE MECANINDUS	ROLLPIN		
31	00 103.085	14	SK-SCHR. M12X25 DIN 933-8.8	VIS M12X25 DIN 933	SCREW M12X25 DIN 933		
32	00 122.108	20	SI-MUTTER M12 DIN 980-8 ZN	ECROU M12 DIN 980-8	NUT M12 DIN 980-8		
33	00 103.087	2	SK-SCHR. M12X35 DIN 933-8.8 ZN	VIS M12X35	SCREW M12X35		
34	00 103.354	8	SK-SCHRAUBE M14X110 DIN931-8.8	VIS	SCREW		
35	00 122.109	8	SICHERUNGSMUTTER M14 DIN 980-8	ECROU „STOVER“	LOCK NUT		
36	00 162.752	8	SCHLEIBE 28X15X3	RONDELLE	WASHER		
37	00 103.043	49	SK-SCHR. M8X20 DIN 933-8.8 ZN	VIS M8X20	SCREW M8X20		
38	00 122.106	80	SI-MUTTER M8 DIN 980-8	ECROU M8 DIN 980	NUT M8 DIN 980		
39	00 103.044	8	SK-SCHR. M 8X25 DIN 933-8.8	VIS M 8X25	SCREW M 8X25		
40	00 108.907	23	FLR-SCHR.M8X20 DIN603 8.8 ZN	VIS M8X20	SCREW M8X20		
41	00 162.601	16	SCHLEIBE 18X8,5X2	RONDELLE	WASHER		
42	00 103.303	1	SK-SCHRAUBE M10X60 DIN 931-8.8	VIS	SCREW		
43	00 122.107	1	SI-MUTTER M10 DIN 980-8	ECROU M10 DIN 980	NUT M10 DIN 980		
44	00 162.602	1	SCHLEIBE 21X10,5X2 DIN 125	RONDELLE	WASHER		
45	00 169.912	3	SCHLEIBE MIT SCHLITZ 11/28X0,75	RONDELLE	WASHER		
46	00 435.749	4	FEDERLASCHE	JUMELLE DE RESSORT	SPRING SHACKLE		
47	00 435.755	4	FEDERLASCHE	JUMELLE DE RESSORT	SPRING SHACKLE		
49	00 122.104	16	SICHERUNGSMUTTER M 6 DIN 980-8	ECROU „STOVER“	LOCK NUT		
50	00 162.405	16	SCHLEIBE 18X6,5X1,5	RONDELLE	WASHER		
51	00 102.40.367.0	1	HEBEL	LEVIER	LEVER		
52	00 438.043	1	ROHRKLAPPSTECKER 8X50	AGRAFE 8X50	SAFETY PIN 8X50		
53	00 543.004	0	OMNIFIT M100 SPEZIAL	PATE FREINAGE D'VIS	SCREW LOCKING PASTE		
54	00 103.40.520.0	1	ABSTREIFTRAEGER S.Z.	RACLEUR SUPPORT	SCRAPER SUPPORT		
55	00 103.086	4	SK-SCHR. M12X30 DIN 933-8.8 ZN	VIS M12X30	SCREW M12X30		
61	00 103.40.456.0	1	KURVENSCHLEIBE LI.S.Z.	PLATEAU A CAME	CAMPLATE	L	
62	00 121.40.369.0	1	OLJEBRONCEBUECHSE 65X55X60	COUSSINET FRITTE	SINTER BEARING BUSH		
71	00 103.40.466.0	1	KURVENSCHLEIBE RE. S.Z.	PLATEAU A CAME	CAMPLATE	R	
72	00 103.40.475.0	1	OLJEBRONZ-BUECHSE	BAGUE	BUSH		

PNR	TEILE-NR	MENGE	BENENNUNG	DESIGNATION	DESCRIPTION	BEMERK/REMARQUE	FU
0.01	00 103.48.000.0	1	PRESSE ABWICKLUNG LANDSBERG	PRESSE	PRESS	(1-14	
0.02	00 103.48.015.0	5	FOERDERKAMM ZUS.	PEIGNE DE TRANSPORT	CONVEYOR	(21-31	
0.03	00 103.48.035.0	5	STUETZLAGER ZUS.	PALIER D'APPUI	SUPPORT BEARING	(51-54,15	
0.04	00 103.48.020.0	2	KAMMHALTER ZUS.	PEIGNE-SUPPORT	PLATE	(41,42	
1	00 103.48.010.0	1	ZENTRALROHR SZ.	TUBE CENTRAL	MAIN TUBULAR ELEMENT		
4	00 103.48.045.0	2	LEITUNG 1	CONDUITE	OVERFLOW PIPE	(62,63	
5	00 103.48.046.0	2	LEITUNG 2	CONDUITE	OVERFLOW PIPE	(62,63	
6	00 103.48.047.0	2	LEITUNG 3	CONDUITE	OVERFLOW PIPE	(62,63	
7	00 103.48.048.0	2	LEITUNG 4	CONDUITE	OVERFLOW PIPE	(62,63	
8	00 103.48.049.0	2	LEITUNG 5	CONDUITE	OVERFLOW PIPE	(62,63	
9	00 190.021	10	SCHMIERNIPPEL AR 1/8" DIN71412	RACCORD DE GRAISSEUR	GREASING NIPPLE		
10	00 448.226	20	VERSCHRAUBUNG GER. R 1/8"	RACCORD VISSE	THREADED UNION		
11	00 101.527	20	SK-SCHRAUBE M18X1,5X45 DIN 961	VIS	SCREW		
12	00 122.119	20	SK-MUTTER M18X1,5	ECROU M18X1,5	NUT M18X1,5		
13	00 101.521	10	SK-SCHRAUBE M16X1,5X40 DIN 961	VIS	SCREW		
14	00 122.138	10	SI-MUTTER M16X1,5 DIN 980	ECROU M16X1,5	NUT M16X1,5		
15	00 543.004	0	OMNIFIT M100 SPEZIAL	PATE FREINAGE D'VIS	SCREW LOCKING PASTE		
21	00 103.48.016.0	1	FOERDERKAMM SZ.	PEIGNE DE TRANSPORT	CONVEYOR		
22	00 103.48.025.0	1	STEUERARM LI.SZ.	BRAS DE COMMANDE	CONTROL ARM	L	
23	00 103.48.030.0	1	STEUERARM RE.SZ.	BRAS DE COMMANDE	CONTROL ARM	R	
25	00 407.502	2	STUETZROLLE	GALET SUPPORT	SUPPORT-ROLLER		
26	00 162.759	6	SCHEIBE 70X50,2X3	RONDELLE	WASHER		
27	00 166.814	4	SCHEIBE 50X35,2X1	RONDELLE	WASHER		
28	00 155.029	2	SICHERUNGSRING 35X1,5 DIN 471	SEGMENT D'ARRET	CIRCLIP		
29	00 172.176	2	SPANNSTIFT 8X70 DIN 1481	GOUPILLE MECANINDUS	ROLLPIN		
30	00 190.002	2	SCHMIERNIPPEL A M8X1 DIN 71412	RACCORD DE GRAISSEUR	GREASING NIPPLE		
31	00 543.014	0	LOCTITE 648/50	LOCTITE 648/50	LOCTITE 648/50		
41	00 103.48.021.0	1	KAMMHALTER SZ.	PEIGNE-SUPPORT	PLATE		
42	00 410.191	1	BUECHSE 50E9X55X30	BAGUE 50E9X55X30	BUSH 50E9X55X30		
51	00 103.48.036.0	1	STUETZLAGER SZ.	PALIER D'APPUI	SUPPORT BEARING		
52	00 103.48.038.0	1	LAGERSCHALE	RONDELLE	TERMINAL RING		
53	00 100.041	2	SK-SCHRAUBE M 8X16 DIN 933-8.8	VIS	SCREW		
54	00 162.776	2	SCHEIBE 17X8,5X3	RONDELLE	WASHER		
62	00 448.125	2	UEBERWURFMUTTER AL 6 DIN 3870	ECROU-CHAPEAU	NUT		
63	00 448.126	2	SCHNEIDRING L 6 DIN 3861	FILIERE	RING		

CLICK HERE TO **DOWNLOAD** THE COMPLETE MANUAL

- Thank you very much for reading the preview of the manual.
- You can download the complete manual from: [www.heydownloads.com](http://www.heydownloads.com) by clicking the link below



- Please note: If there is no response to CLICKING the link, please download this PDF first and then click on it.

CLICK HERE TO **DOWNLOAD** THE COMPLETE MANUAL

PNR	TEILE-NR	MENGE	BENENNUNG	DESIGNATION	DESCRIPTION	BEMERK/REMARQUE	FU
0.01	00 103.59.000.1	1	PU-TASTRAEDER LUFTBEREIFT	PU-RUES PALPEUSE	PU-WHEELS	V (31-48	
0.02	00 500.0.080	2	BEREIFUNG 15X6,0-6 KPL.	PNEUS	TYRES CPTE.	(45-48	
0.03	00 103.50.130.1	1	RADTRAEGER RE.	SUPPORT DE ROUE	WHEEL SUPPORT	(31-38,43-48 R	
0.04	00 161.50.051.0	1	TASTRAD LI.ZUS.	ROUE PALPEUSE	GROUND WHEEL	(31-38,41,42,45-48 L	
31	00 166.402	2	SCHEIBE 26X16,2X1	RONDELLE	WASHER		
32	00 203.33.005.0	2	DECKSCHEIBE	DISQUE DE RECOUVREM.	WASHER		
33	00 162.408	2	SCHEIBE 30X13X5 DIN1542	RONDELLE	WASHER		
34	00 103.086	2	SK-SCHR. M12X30 DIN 933-8.8 ZN	VIS M12X30	SCREW M12X30	242	
35	00 172.116	2	SPANNSTIFT 5X24 DIN 1481	GOUPILLE MECANINDUS	ROLLPIN		
36	00 191.002	2	SCHMIERN. SFG AM 8X1 DIN 71412	RACCORD DE GRAISSAGE	GREASING NIPPLE		
37	00 451.533	2	RADKAPPE	COUVERCLE	CAP		
38	00 451.552	2	LABYRINTHDICHTUNG	JOINT	GASKET		
41	00 161.50.052.0	1	RADTRAEGER LI.SZ.	SUPPORT DE ROUE	WHEEL SUPPORT	L	
42	00 103.50.129.0	1	STREBE LI.	JAMBE DE FORCE GAUCH	STRUT LEFT	L	
43	00 103.50.131.1	1	RADTRAEGER RE.	SUPPORT DE ROUE	WHEEL SUPPORT		
44	00 103.50.135.0	1	STREBE RE.	JAMBE DE FORCE DROIT	STRUT RIGHT		
45	00 451.554	2	FELGE MIT NABE 4,50X6	JANTE DE ROUE	WHEEL RIM	(45,48	
46	00 452.071	2	REIFEN 15X6,0-6 4 PR,RP	PNEUMATIQUE 15X6,0-6	TYRE 15X6,0-6		
47	00 452.514	2	SCHLAUCH 15X6.00-6	TUYAU SOUPLE 15X6.00	TUBE 15X6.00		
48	00 400.218	2	RILLENKUGELL. 6205-2Z DIN625	ROUL. RAINURE A BIL.	BEARING		

PNR	TEILE-NR	MENGE	BENENNUNG	DESIGNATION	DESCRIPTION	BEMERK/REMARQUE	FU
0.01	00 103.42.010.0	1	HYDRAULIK FUER SCHNEIDWERK	LIFT DE HYDRAULIQUE	HYDRAULIC LIFT		
1	00 102.42.105.0	1	HYDROSPEICHER	ACCUMULATEUR DE GAZ	ACCUMULATOR		
2	00 141.42.105.0	1	WINKEL	CORNIERE	ANGLE		
3	00 118.009	2	SK-SCHRAUBE M8X16	VIS	SCREW		
4	00 448.232	1	EINSCHRAUBVERS.GER. R 1/2" 15	RACCORD VISSE	THREADED UNION		
5	00 448.077	1	GER.REDUZIERVERSCHR.	RACCORD REDUCTEUR F.	STRAIGHT REDUCING U.		
6	00 448.1.271	2	T-VERSCHRAUBUNG	RACCORD FILETE REGL.	CONNECTING SCREW		
7	00 448.019	2	EINSTELLB. WINKELVERSCHRAUBUNG	RACCORD FILETE REGL.	CONNECTING SCREW		
8	00 152.72.006.0	1	ROHRSTUTZEN	RACCORD DE TUYAU	PIPE UNION		
9	00 448.1.051	1	REDUZIERSTUTZEN	REDUCTION RACCORD	REDUCTION SOCKET		
10	00 445.1.002	1	ZWEIWEGEHAHN	ROBINET A DEUX VOIES	TWO WAY VALVE		
11	00 448.005	2	UEBERWURFMUTTER AL 8 DIN 3870	ECROU-CHAPEAU	NUT		
12	00 448.006	2	SCHNEIDRING L 8 DIN 3861	FILIERE	RING		
13	00 447.2.202	1	HYDR.SCHLAUCH NW6 L=1200	TUYAU L=1200	TUBE L=1200		
14	00 447.2.206	1	HYDRAULIKSCHLAUCH NW 6 X 850	TUYAU HYDRAULIQUE	HYDRAULIC HOSE		
15	00 442.139	1	HYDR. ZYLINDER DOPPELTW.	LIFT DE HYDRAULIQUE	HYDRAULIC LIFT		
16	00 172.141	1	SPANNSTIFT 6X30 DIN 1481	GOUPILLE MECANINDUS	ROLLPIN		
17	00 162.417	2	SCHEIBE 36X20,5X2	RONDELLE	WASHER		
18	00 172.122	1	SPANNSTIFT 5X40 DIN 1481	GOUPILLE MECANINDUS	ROLLPIN		
19	00 102.21.067.0	1	DROSSEL	PAPILLON	THROTTLE		
20	00 102.42.106.0	1	BOLZEN	AXE	PIN		
21	00 120.315	1	SK-MUTTER M33X1,5	ECROU HEXAGONAL	NUT, HEX.		
22	00 475.165	1	KABELBINDER 4,8X188	ATTACHE-CABLE	STRIP		
23	00 494.346	1	AZB „VORSICHT SPEICHER...“	ETIQUETTE	DECAL		
24	00 415.579	4	O-RING 6.5X1.5	JOINT TORIQUE	O-RING		
25	00 104.906	2	ZYL-SCHR.M10X16 DIN 912-8.8	VIS-CYLINDRIQUE	SCREW		
26	00 165.311	2	FEDERRING 10 DIN 128 ZN	RONDELLE 10 DIN 128	WASHER 10 DIN 128 ZN		
27	00 104.919	2	ZYL-SCHR.M12X20 DIN 912-8.8 ZN	VIS-CYLINDRIQUE	CHEESE HEAD-SCREW		
28	00 165.312	2	FEDERRING 12 DIN 128 ZN	RONDELLE 12 DIN 128	WASHER 12 DIN 128		
31	00 445.056	1	DREIWEGEHAHN 8 L	ROBINET A 3 VOIES	THREE WAY VALVE		
32	00 118.005	4	GEWINDEFORMSCHRAUBE M 6X12-8.8	VIS TARAUDEUSE	STUD		
33	00 494.444	1	AZB „DUERRFUTTERAUFBAU“	ETIQUETTE	DECAL		
34	00 495.418	1	AZB „SCHNEIDWERK“ WERKSTOFF:	ETIQUETTE	DECAL		
35	00 447.2.207	1	HYDR.SCHLAUCH NW6/ 650 MM	TUYAU NW6/ 650 MM	TUBE NW6/ 650 MM		
36	00 415.579	2	O-RING 6.5X1.5	JOINT TORIQUE	O-RING		

PNR	TEILE-NR	MENGE	BENENNUNG	DESIGNATION	DESCRIPTION	BEMERK/REMARQUE	FU
0.01	00	102.77.020.0	1 DEICHSEL M. AUFLAUFAGGREGAT	TIMON	DRAWBAR		
1	00	454.089	1 DEICHSEL M.AUFLAUFEINR. KPL.	TIMON	DRAWBAR	(1-24	
2	00	454.102	1 ZUGOSE MIT SEITENSCHIENE	ANNEAU D'ATTELAGE	TOWING EYE		
3	00	454.103	1 GEHAEUSETEIL	CARTER	CASING	& POS 4.01	
4	80	136.59.100.1	1 STUETZROLLE MIT BUECHSE B=35	GALET SUPPORT	SUPPORT-ROLLER		
4.01	80	136.59.100.1	1 STUETZROLLE MIT BUECHSE B=35	GALET SUPPORT	SUPPORT-ROLLER	+	
5	00	454.105	1 BOLZEN FUER STUETZROLLE	AXE	PIN		
6	00	155.018	2 SICHERUNGSRING 20X1,2 DIN 471	SEGMENT D'ARRET	CIRCLIP		
7	00	454.106	1 LAUFROLLE	POULIE	ROLLER		
8	00	454.107	1 BOLZEN FUER LAUFROLLE	AXE	PIN		
9	00	454.108	1 ANZUGSDAEMPFER KPL.	PLAQUE DE CAOUTCHOUC	DAMPER		
10	00	454.109	1 DRUCKFEDER	RESSORT DE PRESSION	SPRING		
11	00	454.110	1 DRUCKSTUECK	PIECE DE BUTEE	PRESSURE PLATE		
12	00	103.358	2 SK-SCHR.M14X150 DIN 931 8.8 ZN	VIS M14X150	SCREW M14X150		
13	00	122.059	2 SICHERUNGSMUTTER M14 DIN 980-8	ECROU „STOVER“	LOCK NUT		
14	00	454.111	1 UMLENKHEBEL	LEVIER DE RENVOI	REVERSING LEVER		
15	00	454.112	1 GABELKOPF G 12X48 DIN 71752	CHAPE G 12X48	FORK-TOP G 12X48		
16	00	454.116	2 STAHLSEIL 5X440	CABLE 5X440	CABLE 5X440		
16.01	00	454.116	2 STAHLSEIL 5X440	CABLE 5X440	CABLE 5X440	+	
17	06	01035	1 GASDRUCKDAEMPFER 300 N/120	PLAQUE DE CAOUTCHOUC	DAMPER		
18	00	454.115	1 HANDBREMSHEBEL KPL.	LEVIER DE FREIN MAIN	HAND BRAKE LEVER		
19	00	180.263	1 BOLZEN 10X33X29 DIN 1434	AXE 10X33X29	PIN 10X33X29		
20	00	180.264	1 BOLZEN 10X40X36 DIN 1434	AXE 10X40X36	PIN 10X40X36		
21	00	103.326	1 SK-SCHR. M 12X70 DIN 931-8.8	VIS M 12X70	SCREW M 12X70		
22	00	103.328	1 SK-SCHR. M12X80 DIN 931 8,8 ZN	VIS M12X80 DIN 931	SCREW M12X80 DIN 931		
23	00	180.295	1 BOLZEN 16X40X35 DIN 1434	AXE 16X40X35	PIN 16X40X35		
24	00	100.480	2 SK-SCHR. M10X20 DIN 931 8.8	VIS M10X20	SCREW M10X20		
42	00	-	0 --	--	--	*61/73/140	
43	00	430.121	1 ABBREISSEIL 8X1500	CABLE 8X1500	CABLE 8X1500		
44	00	464.125	1 SCHERGLIED 4,5X26	ELEMENT DE CISAILLE.	LINK		
45	00	464.206	1 KNOTENKETTE 17 GL. 3,8	CHAINE M16X1,5	CHAIN M16X1,5		
51	00	454.089.001	1 HANDBREMSHEBEL KPL.	LEVIER DE FREIN MAIN	HAND BRAKE LEVER	+	
52	00	454.089.002	1 ABBREISSRING	BAGUE	RING	+	
53	00	454.089.003	2 SEITENHEBELBLECH	PLAQUE	PLATE	+	
54	00	454.089.004	1 ZAHNSEGMENT KPL.	SEGMENT DENTE	GEAR SEGMENT	+	(54-56
55	00	103.280	2 SK-SCHR.M 8X25 DIN 931 8.8 ZN	VIS M 8X25	SCREW M 8X25	+	
56	00	122.005	2 SK-MUTTER M8 DIN 985-8	ECROU M8 DIN 98	NUT M8 DIN 98	+	
57	00	454.089.005	1 FIXIERLASCHE S=6MM	FIXATION	FASTENER	+	
58	00	122.108	4 SI-MUTTER M12 DIN 980-8 ZN	ECROU M12 DIN 980-8	NUT M12 DIN 980-8	+	
59	00	454.089.006	1 DISTANZROHR	TUBE	TUBE	+	
60	00	103.323	1 SK-SCHRAUBE M12X55 DIN 931-8.8	VIS	SCREW	+	
61	00	103.320	1 SK-SCHR. M12X40 DIN 931-8.8 ZN	VIS M12X40	SCREW M12X40	+	
62	00	180.265	1 SPLINTBOLZEN 10X50X46	BOULON 10X50X46	PIN 10X50X46	+	
63	00	162.451	2 SCHEIBE 21X10,5X1,25	RONDELLE	WASHER	+	
64	00	175.148	3 SPLINT 2,5X25 DIN 94	GOUPILLE FENDUE	COTTERPIN 2,5X25	+	
65	00	454.089.007	1 DISTANZHUELSE 20X5X32	DOUILLE D'ECARTEMENT	SPACER 20X5X32	+	
66	00	180.266	1 SPLINTBOLZEN 10X55X51	BOULON 10X55X51	PIN 10X55X51	+	
67	00	454.089.008	1 DISTANZBUEGEL	ETRIER	CROSSTIE	+	
68	00	162.160	13 SCHEIBE 13 0 DIN 125 ZN	RONDELLE	WASHER	+	
69	00	454.089.009	1 DISTANZHUELSE 20X4X32	DOUILLE 20X4X32	SPACER 20X4X32	+	
70	00	103.332	2 SK-SCHR. M12X100 DIN931 8.8 ZN	VIS M12X100	SCREW M12X100	+	
71	00	454.089.010	1 DISTANZHUELSE 24X5,5X28	DOUILLE D'ECARTEMENT	SPACER 24X5,5X28	+	
72	00	180.264	1 BOLZEN 10X40X36 DIN 1434	AXE 10X40X36	PIN 10X40X36	+	
73	00	162.159	1 SCHEIBE A10,5 DIN9021	RONDELLE	WASHER	+	
74	00	454.089.011	2 STAHLDRAHTSEIL L=490MM	CABLE DE FIL D'ACIER	STEEL WIRE CABLE	+	
75	00	454.089.012	1 GASFEDER SUSPA F=2300N/H=125MM	RESSORT DE GAZ	SPRING	+	

PNR	TEILE-NR	MENGE	BENENNUNG	DESIGNATION	DESCRIPTION	BEMERK/REMARQUE	FU
0.01	00 103.80.100.0	1	ANTRIEB VORNE	ENTRAINEMENT (AVANT)	DRIVE (FRONT)	(1-44,53-73	
0.02	00 103.80.105.0	1	ANTRIEBSWELLE ZUS.	ARBRE D'ENTRAINEMENT	SHAFT	(9,53	
0.03	00 103.80.024.1	1	KETTENSPIANNER KPL.	KIT A TENSION	TENSIONER	(22-26	
1	00 -	0	--	--	--	* 200	
2	00 100.109	4	SK-SCHRAUBE M14X40 DIN 933 8,8	VIS	SCREW		
3	00 165.013	4	HEDTMANN-SICHERHEITSRING 14	RONDELLE GROWER	WASHER, SPRING		
4	00 162.752	4	SCHLEIBE 28X15X3	RONDELLE	WASHER		
5	00 457.658	1	SCHUTZTOPF	CUVETTE DE PROTEC.	COVER		
6	00 103.041	4	SK-SCHRAUBE M8X16 DIN 933-8.8	VIS	SCREW		
7	00 165.310	4	FEDERRING A 8 DIN 127	RONDELLE A 8 DIN 127	WASHER A 8 DIN 127		
8	00 162.407	4	SCHLEIBE 18X8,5X2	RONDELLE	WASHER		
9	00 103.80.106.0	1	ANTRIEBSWELLE	ARBRE D'ENTRAINEMENT	SHAFT		
13	00 107.80.109.0	1	SCHALTCLAUE	PATTE DE COMM.	FORK	-4503	
13.01	00 107.80.109.1	1	SCHALTCLAUE	PATTE DE COMM.	FORK	+4504	
14	00 166.822	1	SCHLEIBE 50X42,2X2	RONDELLE	WASHER		
15	00 103.80.012.2	1	KETTENRAD Z=13/2 KPL.	ROUE DE CHAINE	SPROCKET	(15,16	
16	00 410.187	1	GEROLLTE BUECHSE 40E9X44X40	DOUILLE	BUSH		
18	00 462.702	1	ROLLENKETTE ASA 80/2 72 GLD.	CHAINE	ROLLER CHAIN		
19	00 462.960	1	SCHLUSSGLIED ASA 80/2 GER	MAILLON D. ATTACHE	LINK, CONNECTING		
22	00 103.80.025.1	1	SPANNHEBEL	LEVIER	LEVER		
23	00 155.018	2	SICHERUNGSRING 20X1,2 DIN 471	SEGMENT D'ARRET	CIRCLIP		
24	00 103.80.035.0	2	KETTENRAD Z=10	ROUE DE CHAINE	SPROCKET	648	
25	00 121.80.027.0	1	DISTANZRING	BAGUE	RING		
26	00 162.508	1	SCHLEIBE 30X20,5X1,5	RONDELLE	WASHER		
27	00 155.018	1	SICHERUNGSRING 20X1,2 DIN 471	SEGMENT D'ARRET	CIRCLIP		
28	00 162.604	2	SCHLEIBE 36X20,5X2	RONDELLE	WASHER		
29	00 103.80.028.0	1	SPANNSCHRAUBE	VIS DE SERRAGE	SCREW		
30	00 100.086	1	SK-SCHRAUBE M12X30 DIN 933-8.8	VIS	SCREW		
31	00 435.108	1	DRUCKFEDER	RESSORT DE PRESSION	SPRING		
32	00 162.751	1	SCHLEIBE 28X13X3 DIN 1542	RONDELLE	WASHER		
33	00 120.111	3	SK-MUTTER M12 DIN 934-8	ECROU HEXAGONAL	NUT, HEX.		
34	00 121.80.043.0	1	SCHALTGABEL KPL.	FOURCHETTE D'EMBRAY	SHIFT FORK	(34-36 -4503	
34.01	00 107.80.110.0	1	SCHALTGABEL ZUS.	FOURCHETTE D'EMBRAY	SHIFT FORK	(34-36 +4504	
35	00 400.006	4	KUGELLAGER 608 2Z	ROULEMENT A BILLES	BEARING, BALL	648	
36	00 126.85.113.0	2	KUGELLAGERBOLZEN	AXE ROULEMENT BILLES	BALL BEARING PIN	648	
37	00 103.80.060.0	1	BOLZEN	AXE	PIN	-4503	
37.01	00 103.80.060.1	1	BOLZEN	AXE	PIN	+4504	
38	00 172.167	3	SPANNSTIFT 8X30 DIN 1481	GOUPILLE MECANINDUS	ROLLPIN		
39	00 172.119	3	SPANNSTIFT 5X30 DIN 1481	GOUPILLE MECANINDUS	ROLLPIN		
40	00 103.80.059.0	1	HEBEL SCHW.	LEVIER	LEVER		
41	00 490.960	1	GRIFF	POIGNEE	HANDLE		
42	00 107.80.108.0	1	KONSOLE	CONSOLE	BRACKET	-4503	
42.01	00 107.80.108.1	1	KONSOLE	CONSOLE	BRACKET	+4504	
43	00 100.064	2	SK-SCHRAUBE M10X25 DIN 933-8.8	VIS	SCREW		
44	00 122.057	2	SICHERUNGSMUTTER M10 DIN 980-8	ECROU „STOVER“	LOCK NUT		
46	00 155.032	1	SICHERUNGSRING 40X1,75 DIN471	SEGMENT D'ARRET	CIRCLIP		
53	00 103.80.107.0	1	KUPPLUNGSNABE	MOYEU D'EMBRAYAGE	SPROCKET		
54	00 406.142	1	FLANSCHLAGER FME 50	PALIER A BRIDE	FLANGE BEARING	648	
56	00 122.058	2	SICHERUNGSMUTTER M12 DIN 980-8	ECROU „STOVER“	LOCK NUT		
57	00 103.80.064.0	1	ROHR	TUBE	RING		
58	00 100.088	1	SK-SCHRAUBE M12X40 DIN 933 8,8	VIS	SCREW		
59	00 162.621	3	SCHLEIBE 24X13X2	RONDELLE	WASHER		
60	00 103.80.055.0	1	SCHALTHEBEL SCHW.ZUS.	LEVIER DE COMMANDE	SHIFT LEVER		
61	00 155.010	1	SICHERUNGSRING 12X1 DIN 471	SEGMENT D'ARRET	CIRCLIP		
62	00 103.80.065.1	1	LASCHE	ECLISSE	PLATE		
63	00 435.188	1	DRUCKFEDER	RESSORT DE PRESSION	SPRING		
64	00 103.80.068.0	1	SCHLEIBE 50/11X4	RONDELLE	WASHER		
65	00 162.701	1	SCHLEIBE 21X10,5X2,5	RONDELLE	WASHER		
66	00 172.076	1	SPANNSTIFT 4X20 DIN 1481	GOUPILLE MECANINDUS	ROLLPIN		
67	00 100.027	1	SK-SCHRAUBE M 6X35 DIN 933-8.8	VIS	SCREW		
68	00 122.054	1	SICHERUNGSMUTTER M 6 DIN 980	ECROU „STOVER“	LOCK NUT		
69	00 103.80.061.0	1	HEBEL SCHW.ZUS.	LEVIER	LEVER		
70	00 435.306	1	ZUGFEDER	RESSORT DE TRACTION	SPRING		
73	00 191.002	1	SCHMIERN. SFG AM 8X1 DIN 71412	RACCORD DE GRAISSAGE	GREASING NIPPLE		
74	00 120.110	1	SK-MUTTER M 10 DIN 934-8	ECROU M 10	NUT M 10		
75	00 102.80.111.0	1	FLACHSTAHL	FER-PLAT	PLATE		
76	00 166.810	1	SCHLEIBE 65X40,2X2	RONDELLE	WASHER		
77	00 166.825	1	SCHLEIBE 50X40,2X1	RONDELLE	WASHER		
78	00 166.812	1	SCHLEIBE 70X50,2X2	RONDELLE	WASHER		
81	00 104.309	4	ZYL.SCHR. M12X35 DIN 7984-8.8	VIS A TETE CYLINDR.	CHEESE HEAD SCREW		

PNR	TEILE-NR	MENGE	BENENNUNG	DESIGNATION	DESCRIPTION	BEMERK/REMARQUE	FU
0.01	00	103.62.100.0	1 KETTENTRIEB	ENTRAINEMENT	CAIN DRIVE	(1-35	
1	00	103.63.125.0	1 NABE SZ.	MOYEU	HUB		
2	00	141.63.125.0	1 NABE SZ.	MOYEU	HUB		
3	00	103.63.105.0	1 FLANSCH SCHW.ZUS.	BRIDE	FLANGE		
4	00	141.63.132.0	1 DISTANZROHR	TUBE	TUBE		
5	00	155.145	2 SICHERUNGSRING 68X2,5 DIN 472	SEGMENT D'ARRET	CIRCLIP		
6	00	155.032	2 SICHERUNGSRING 40X1,75 DIN471	SEGMENT D'ARRET	CIRCLIP		
7	00	162.609	4 SCHEIBE 65X40,2X2	RONDELLE	WASHER		
8	00	400.177	2 RILLENKLAG. 6008 2RS DIN 625	ROUL. RAINURE A BIL.	BEARING, BALL		
9	00	150.107	1 PASSFEDER A 8X7X32 DIN 6885	CLAVETTE	KEY		
10	00	150.138	1 PASSFEDER A 12X8X70 DIN 6885	CLAVETTE	KEY		
11	00	103.088	2 SK-SCHR. M12X40 DIN 933-8.8	VIS M12X40	SCREW M12X40		
12	00	120.161	2 SK-MUTTER M12 DIN 934-8 ZN	ECROU M12	NUT M12		
13	00	165.312	4 FEDERRING 12 DIN 128 ZN	RONDELLE 12 DIN 128	WASHER 12 DIN 128		
14	00	104.083	2 ZYL-SCHR. M12X30 DIN 912 8,8	VIS-CYLINDRIQUE	BOLT, SOCKET		
15	00	445.405	1 HYDRAULIK-MOTOR OMP 315	HYDRAULIQUE-MOTEUR	HYDRAULICMOTOR		
15.01	00	445.234	1 DICHTUNGSSATZ F. DANFOSS 315	GARNITURE DE JOINTS	SET OF GASKETS		
16	00	462.120	1 E-ROLLENKETTE 3/4" ASA60 64GL.	CHAINE A SIMPLES R.	SINGLE ROLLER CHAIN	(16,35	
17	00	108.190	5 FLR-SCHR. M8X40 DIN 603-4.6	VIS A TETE BOMBEE	BOLT, SLOTTED		
18	00	162.402	5 SCHEIBE 24X8,5X1,5	RONDELLE	WASHER		
19	00	165.310	5 FEDERRING A 8 DIN 127	RONDELLE A 8 DIN 127	WASHER A 8 DIN 127		
20	00	120.159	5 SK-MUTTER M8 DIN 934-8 ZN	ECROU M8 DIN 934	NUT M8 DIN 934		
21	00	103.137	1 SK-SCHRAUBE M16X 80 DIN 933	VIS	SCREW		
22	00	120.113	1 SK-MUTTER M 16 DIN 934-8	ECROU HEXAGONAL	NUT, HEX.		
23	00	448.232	1 EINSCHRAUBVERS.GER. R 1/2" 15	RACCORD VISSE	THREADED UNION		
24	00	448.230	1 VERSCHRAUBUNG GER. 18 LR	RACCORD VISSE	THREADED UNION		
25	00	166.439	2 SCHEIBE 48X40,2X1	RONDELLE	WASHER		
27	00	103.63.115.0	1 SCHUTZ SCHW.ZUS.	PROTECTION DROITE	PROTECTION RIGHT		
28	00	103.043	2 SK-SCHR. M8X20 DIN 933-8.8 ZN	VIS M8X20	SCREW M8X20		
29	00	127.011	2 BLINDNIETMUTTER M8, STAHL KLE	FAUX RIVET	BLIND RIVET		
30	00	162.416	2 SCHEIBE 24X13X2	RONDELLE	WASHER		
35	00	462.906	1 SCHLUSSGLIED ASA 60 GER.DRAHTV	MAILLON D. ATTACHE	LINK, CONNECTING		

PNR	TEILE-NR	MENGE	BENENNUNG	DESIGNATION	DESCRIPTION	BEMERK/REMARQUE	FU
0.01	00	445.145	1 STEUERGERAETEBLOCK KOMPL.	LM0 BOITE DE CONTROLE	CONTROL BOX	(1-78	
0.02	37	013205	1 EINGANGSPLATTE	PLATEAU	PLATE	(11-18	
0.03	00	445.258	1 SCHIEBEVENTIL	SOUPAPE C	VALVE C	(41-58	
0.04	00	445.262	1 ZWISCHENPLATTE	PLATINE	PLATE	(61-66	
0.05	37	013207	2 ZWISCHENPLATTE	PLATINE	PLATE	(71-78	
1	00	445.260	2 EXPANDER -VERSCHLUSSTOPFEN	TENDEUR	STRETCHER		
11	00	445.259.001	1 VERSCHLUSSSCHRAUBE	VIS DE FERMETURE	PLUG, DRAIN		
12	00	445.259.002	1 DRUCKFEDER	RESSORT DE PRESSION	SPRING		
13	00	415.316	1 O-RING 12X2	JOINT TORIQUE	O-RING		
14	37	247340	1 O-RING	JOINT TORIQUE	O-RING		
15	00	415.309	1 O-RING 8X2	JOINT TORIQUE	O-RING		
16	00	445.264.010	1 O-RING 6,75X1,78	JOINT TORIQUE	O-RING		
17	00	415.316	1 O-RING 12X2	JOINT TORIQUE	O-RING		
18	00	167.412	1 SCHEIBE CU 22/27X1,5	RONDELLE	WASHER		
19	37	238500	1 VERSCHLUSSSCHRAUBE	VIS DE FERMETURE	PLUG, DRAIN		
20	00	173.081	1 SPANNSTIFT 4X30 DIN 1481	GOUPILLE	ROLLPIN		
41	00	445.258.001	1 GS-DOPPELHUB-MAGNET	AIMANT	MAGNET		
42	00	445.264.008	2 O-RING 23X2	JOINT TORIQUE	O-RING		
43	00	162.157	1 SCHEIBE A 6,4 DIN 125	RONDELLE	WASHER		
44	00	445.264.009	2 O-RING 6X1,5	JOINT TORIQUE	O-RING		
45	00	445.264.002	2 DRUCKFEDER	RESSORT DE PRESSION	SPRING		
46	00	445.264.003	2 SCHEIBE	RONDELLE	WASHER		
47	00	445.264.004	1 VENTILSCHRAUBE	VIS DE SOUPAPE	BOLT		
48	00	415.309	3 O-RING 8X2	JOINT TORIQUE	O-RING		
49	00	445.264.010	2 O-RING 6,75X1,78	JOINT TORIQUE	O-RING		
50	00	445.264.005	1 STIFT	GOUPILLE	PIN		
51	00	445.264.006	1 KAPPE	CAPUCHON	CAP		
52	00	162.109	1 SCHEIBE A 12,5X6,4X1,6 DIN 125	RONDELLE	WASHER		
53	00	104.031	2 ZYLINDERSCHRAUBE M6X18	VIS A TETE CYLINDR.	CHEESEHEAD BOLT		
54	00	445.264.007	1 DICHTSATZ	GARNITURE DE JOINTS	SET OF GASKETS		
55	00	-	0 --	--	--	)	
56	37	238430	1 VERSCHLUSSSCHRAUBE	VIS DE FERMETURE	PLUG, DRAIN		
57	00	167.407	1 CU-SCHEIBE 10/14 X 1	RONDELLE	WASHER		
58	37	229240	1 VENTILPLAETTCHEN	TETE DE SOUPAPE	VALVE DISC		
61	00	445.262.001	1 ZWISCHENPLATTE	PLATINE	PLATE		
62	00	445.263.002	1 SCHRAUBE	VIS	SCREW		
63	00	445.263.003	2 BLINDNIET	FAUX RIVET	BLIND RIVET		
64	00	445.263.004	1 SCHILD JOHN DEERE	PLAQUE	SHIELD		
65	00	415.309	2 O-RING 8X2	JOINT TORIQUE	O-RING		
66	00	415.304	1 O-RING 4X1,5	JOINT TORIQUE	O-RING		
71	37	225851	2 2/2 WEGE SITZVENTIL	SOUPAPE	VALVE		
72	37	225853	2 MAGNETSPULE	SOLENOIDE	SOLENOID		
76	00	415.309	2 O-RING 8X2	JOINT TORIQUE	O-RING		
77	00	445.261.004	2 VERSCHRAUBUNG	RACCORD VISSE	THREADED UNION		

PNR	TEILE-NR	MENGE	BENENNUNG	DESIGNATION	DESCRIPTION	BEMERK/REMARQUE	FU
0.01	00 121.81.000.0	1	MAEHGETRIEBE MONT. KPL.	BOITER POUR FAUCHE	MOWER GEARBOX	(1-27, FU:	1
0.02	00 121.81.001.0	1	MAEHGETRIEBE KPL.	BOITER POUR FAUCHE	MOWER GEARBOX	(1-23	
1	00 121.81.002.0	1	GEHAEUSEBODEN	FOND DE BOITE	HOUSING BOTTOM	504	
2	00 121.81.003.0	1	GEHAEUSEDECKEL	COUVERCLE DE BOITIER	HOUSING COVER	504	
3	00 121.81.020.0	1	STIRNRAD Z=23	ENGRENAGE	GEAR WHEEL CPTE.		
4	00 400.131	2	RILLENKUGELLAGER 6010 DIN 625	ROULEM.DE BUTEE	BEARING		
5	00 415.243	2	WELLENDICHTRING A 72X50X8	BAGNE D ETANCHEITE	OIL SEAL		
6	00 121.81.004.0	1	EINGANGSWELLE	ARBRE D'ENTREE	INPUT SHAFT	648	
7	00 121.81.007.0	1	STIRNRAD Z=16	ENGRENAGE	GEAR WHEEL CPTE.		
8	00 400.222	2	RILLENKUGELLAGER 6207 DIN625	ROULEM.DE BUTEE	BEARING	648	
9	00 121.81.005.0	2	RING	BAGUE	RING		
10	00 155.029	2	SICHERUNGSRING 35X1,5 DIN 471	SEGMENT D'ARRET	CIRCLIP		
11	00 415.088	1	WELLENDICHTRING A 35X62X7	BAGNE D ETANCHEITE	OIL SEAL		
12	00 121.81.006.0	1	WELLE	ARBRE	SHAFT	648	
13	00 121.81.010.0	1	STIRNRAD Z=20	ENGRENAGE	GEAR WHEEL CPTE.		
14	00 400.119	2	RILLENKUGELLAGER 6006 DIN625	ROULEM.DE BUTEE	BEARING	648	
15	00 155.026	4	SICHERUNGSRING 30X1,5 DIN471	SEGMENT D'ARRET	CIRCLIP		
16	00 150.321	1	PASSFEDER B 10X8X36 DIN 6885	CLAVETTE	KEY		
17	00 172.191	2	SPANNSTIFT 10X24 DIN 1481	GOUPILLE MECANINDUS	ROLLPIN		
18	00 103.046	7	SK-SCHRAUBE M8X35 DIN 933-8.8	VIS	SCREW		
19	00 122.106	7	SI-MUTTER M8 DIN 980-8	ECROU M8 DIN 980	NUT M8 DIN 980		
20	00 121.81.024.0	1	SCHUTZTOPF	CUVETTE DE PROTEC.	COVER		
21	00 103.041	4	SK-SCHRAUBE M8X16 DIN 933-8.8	VIS	SCREW		
22	00 162.407	4	SCHEIBE 18X8,5X2	RONDELLE	WASHER		
23	00 165.310	4	FEDERRING A 8 DIN 127	RONDELLE A 8 DIN 127	WASHER A 8 DIN 127		
24	00 121.81.012.0	1	STUETZE LINKS	SUPPORT	SUPPORT	L -5228	
24.01	00 121.81.012.1	1	STUETZE LINKS	SUPPORT	SUPPORT	L +5229	
25	00 121.81.013.0	1	STUETZE RECHTS	SUPPORT	SUPPORT	R -5228	
25.01	00 121.81.013.1	1	STUETZE RECHTS	SUPPORT	SUPPORT	R +5229	
26	00 103.321	2	SK-SCHR. M12X45 DIN 931 8.8 ZN	VIS M12X45	SCREW M12X45		
27	00 112.108	2	SICHERUNGSMUTTER	ECROU „STOVER“	LOCK NUT		
28	00 107.075	1	VERSCHL.SCHR. M 22X1,5 DIN 906	BOUCHON D'USURE	LOCKING SCREW		

1 FU: NICHT FUER TIEFLIEGENDE DEICHSEL  
1 FU: NOT FOR LOW HITCH DRAWBAR  
1 FU: NE PAS POUR TIMON SURBAISSE

PNR	TEILE-NR	MENGE	BENENNUNG	DESIGNATION	DESCRIPTION	BEMERK/REMARQUE	FU
1	00 455.277/743	1	GELENKWELLE WWZ2380-SD15-1110	ARBRE A CARDANS	P.T.O.DRIVE SHAFT		
2	45 185915	1	GELENKWELLENHAELFTE INNEN	MOITIE D'ARBRE	DRIVE SHAFT HALF		
3	45 111493	1	GELENKWELLENHAELFTE AUSSEN	MOITIE D'ARBRE	DRIVE SHAFT HALF		
4	45 180219	1	SCHUTZHAELFTE AUSSEN	DEMI-PROTECTION	SHIELD		
5	45 180230	1	SCHUTZHAELFTE INNEN	DEMI-PROTECTION	SHIELD		
11	45 366838	1	AUFSTECKGABEL MIT SCHIEBESTIFT	MACHOIRE A VERROUILL	YOKE, OUTER		
12	45 339107	1	SCHIEBESTIFT KPL.	CHEVILLE COULISSANTE	PIN, QUICK RELEASE		
13	45 178116	6	SK-SCHRAUBE M10X25 DIN 933	VIS	SCREW		
14	45 178114	6	FEDERRING DIN 127-A10	RONDELLE GROWER	WASHER, SPRING		
15	45 366858	1	FLANSCHGABEL	MACHOIRE A BRIDE	FLANGE YOKE		
16	45 111492	1	NOCKENSCHALTKUPPLUNG	LIMITEUR A CAMES	CAMTYPE CUT O.CLUTCH		
21	45 382701	4	KREUZGARNITUR KPL.	CROISILLON	CROSS		
22	45 084099	4	KEGEL-SCHMIERNIPPEL	RACCORD DE GRAISSAGE	GREASING NIPPLE		
23	45 164466	8	RONDE	RONDELLE	PLATE		
24	45 384517	2	DOPPELGABEL MIT SCHMIERNIPPEL	MACHOIRE DOUBLE	DOUBLE YOKE		
25	45 020672	2	KEGEL-SCHMIERNIPPEL	RACCORD DE GRAISSAGE	GREASING NIPPLE		
26	45 366860	1	RILLENGABEL	MACHOIRE A GORGE	YOKE INNER		
27	45 020614	2	SPANNSTIFT 10X65	GOUPILLE MECANINDUS	ROLLPIN		
28	45 046677	1	PROFILROHR, BESCHICHTET	TUBE PROFILE	PROFILE TUBE		
29	45 057247	1	PROFILROHR	TUBE PROFILE	PROFILE TUBE		
30	45 366861	1	RILLENGABEL	MACHOIRE A GORGE	YOKE INNER		
51	45 365715	2	SCHUTZTRICHTER	CONE PROTECTEUR	GUARD CONE		
52	45 365305	14	SCHRAUBE	VIS	SCREW		
53	45 365717	2	GLEITRING	BAGUE DE GLISSEMENT	BEARING		
54	45 172750	2	SCHUTZTRICHTER	CONE PROTECTEUR	GUARD CONE		
55	45 087279	2	GLEITRING	BAGUE DE GLISSEMENT	BEARING		
56	45 382078	3	HALTEKETTE	CHAINETTE	CHAIN		

PNR	TEILE-NR	MENGE	BENENNUNG	DESIGNATION	DESCRIPTION	BEMERK/REMARQUE	FU
1	00	455.256/741	1 GELENKWELLE WWE2380-SD15-1110	ARBRE A CARDANS	P.T.O.DRIVE SHAFT		
2	00	455.741	1 GELENKWELLENHAELFTE INNEN	MOITIE D'ARBRE	DRIVE SHAFT HALF		
3	00	455.256	1 GELENKWELLENHAELFTE AUSSEN	MOITIE D'ARBRE	DRIVE SHAFT HALF		
4	45	85.102	1 SCHUTZHAELFTE AUSSEN	DEMI-PROTECTION	SHIELD		
5	45	85.104	1 SCHUTZHAELFTE INNEN	DEMI-PROTECTION	SHIELD		
11	45	21.10.810	1 AUFSTECKGABEL KPL.	MACHOIRE A VERROUILL	YOKE, OUTER		
12	45	101	1 SCHIEBESTIFT	CHEVILLE COULISSANTE	PIN, QUICK RELEASE		
13	45	59.110.11	1 NOCKENSCHALTKUPPLUNG KPL.	LIMITEUR DEBRAYABLE	CAM-TYPE CUT OUT	*266	
21	45	21.06.00	2 KREUZGARNITUR KPL.	CROISILLON	CROSS		
22	45	63.27.00	3 KEGEL-SCHMIERNIPPEL	RACCORD DE GRAISSAGE	GREASING NIPPLE		
23	45	21.06.70	4 RONDE	RONDELLE	PLATE		
24	45	21.91.05	1 DOPPELGABEL	MACHOIRE DOUBLE	DOUBLE YOKE		
25	45	63.12.01	1 KEGEL-SCHMIERNIPPEL	RACCORD DE GRAISSAGE	GREASING NIPPLE		
26	45	21.11.810	1 RILLENGABEL	MACHOIRE A GORGE	YOKE INNER		
27	45	61.05.04	2 SPANNSTIFT	GOUPILLE MECANINDUS	ROLLPIN		
28	45	75.11.96	1 PROF. OVAGA	PROFILE	PROFILE OVGA		
29	45	75.16.16	1 PROFIL 1 G	PROFILE	SECTION		
30	45	21.12.00	1 RILLENGABEL	MACHOIRE A GORGE	YOKE INNER		
31	45	21.00.00	1 KREUZGARNITUR KPL.	CROISILLON	CROSS		
51	45	85.00.01	1 SCHUTZTRICHTER	CONE PROTECTEUR	GUARD CONE		
52	45	60.15.00	8 SCHRAUBE	VIS	SCREW		
53	45	82.83.13	1 GLEITRING	BAGUE DE GLISSEMENT	BEARING		
54	45	85.14.106	1 SCHUTZTRICHTER	CONE PROTECTEUR	GUARD CONE		
55	45	82.83.06	2 GLEITRING	BAGUE DE GLISSEMENT	BEARING		
56	45	82.85.00	1 STUETZRING	BAGUE DE SUPPORT	RING		
57	45	85.15.05	1 SCHUTZTRICHTER	CONE PROTECTEUR	GUARD CONE		
58	45	82.36.03	1 HALTEKETTE	CHAINETTE	CHAIN		
59	45	82.36.08	1 HALTEKETTE	CHAINETTE	CHAIN		

PNR	TEILE-NR	MENGE	BENENNUNG	DESIGNATION	DESCRIPTION	BEMERK/REMARQUE	FU
1	00	456.204/359	1 GELENKWELLE MIT SCHUTZ	ARBRE A CARDANS	P.T.O.DRIVE SHAFT		
2	00	456.359	1 GELENKWELLENHAELFTE INNEN	MOITIE D'ARBRE	DRIVE SHAFT HALF		
3	00	456.204	1 AEUSSERE GELENKWELLENHAELFTE	DEMI-TRANSMISSION	OUTER PTO DRIVE HALF		
4	45	85.102	1 SCHUTZHAELFTE AUSSEN	DEMI-PROTECTION	SHIELD		
5	45	85.101	1 SCHUTZHAELFTE INNEN	DEMI-PROTECTION	SHIELD		
11	45	21.10.10	1 AUFSTECKGABEL 1 3/8" 6-TLG	MACHOIRE A VERROUILL	YOKE, OUTER		
12	45	101	1 SCHIEBESTIFT	CHEVILLE COULISSANTE	PIN, QUICK RELEASE		
13	45	-	0 NOCKENSCHALTKUPPLUNG	LIMITEUR DEBRAYABLE	CUT OUT CLUTCH	*276	
21	45	21.00.00	3 KREUZGARNITUR KPL.	CROISILLON	CROSS		
22	45	63.27.00	3 KEGEL-SCHMIERNIPPEL	RACCORD DE GRAISSAGE	GREASING NIPPLE		
23	45	63.22.01	1 KEGELSCHMIERNIPPEL	GRAISSEUR	GREASE NIPPLE		
24	45	21.41.00	1 FLANSCHGABEL	FOURCHE A BRIDE	FLANGE FORK		
25	45	60.68.00	2 GLEITSCHIEBE	DISQUE DE GLISSEMENT	SLIDING WASHER		
26	45	90.00.01	1 FUEHRUNGSSCHIEBE	DISQUE DE GUIDAGE	GUIDE WASHER		
27	45	21.41.01	1 FLANSCHGABEL	MACHOIRE A BRIDE	FLANGE YOKE		
28	45	60.04.19	6 SK-SCHRAUBE	VIS	SCREW		
29	45	60.51.00	6 SK-MUTTER	ECROU HEXAGONAL	NUT, HEX.		
30	45	21.11.10	1 INNENGABEL F. OVGA	FOURCHE	INSIDE FORK		
31	45	61.05.04	2 SPANNSTIFT	GOUPILLE MECANINDUS	ROLLPIN		
32	45	75.11.96	1 PROF. OVGA	PROFILE	PROFILE OVGA		
33	45	75.16.16	1 PROFIL 1 G	PROFILE	SECTION		
34	45	21.12.00	1 RILLENGABEL	MACHOIRE A GORGE	YOKE INNER		
51	45	85.15.51	1 SCHUTZTRICHTER	CONE PROTECTEUR	GUARD CONE		
52	45	60.15.00	2 SCHRAUBE	VIS	SCREW		
53	45	82.83.06	2 GLEITRING	BAGUE DE GLISSEMENT	BEARING		
54	45	85.15.05	1 SCHUTZTRICHTER	CONE PROTECTEUR	GUARD CONE		
55	45	82.36.03	1 HALTEKETTE	CHAINETTE	CHAIN		

PNR	TEILE-NR	MENGE	BENENNUNG	DESIGNATION	DESCRIPTION	BEMERK/REMARQUE	FU
0.01	00 103.58.110.0	1	3-WEGHAHN FUER 5.FUNKTION	ROBINET A 3 VOIES	THREE WAY VALVE	(1-6	
1	00 445.056	1	DREIWEGHAHN 8 L	ROBINET A 3 VOIES	THREE WAY VALVE		
2	00 118.005	4	GEWINDEFORMSCHRAUBE M 6X12-8.8	VIS TARAUEUSE	STUD		
3	00 494.444	1	AZB „DUERRFUTTERAUFBAU“	ETIQUETTE	DECAL		
4	00 495.418	1	AZB „SCHNEIDWERK“ WERKSTOFF:	ETIQUETTE	DECAL		
5	00 447.2.214	1	HYDRAULIK SCHLAUCH	LIFT DE HYDRAULIQUE	HYDRAULIC LIFT		
6	00 447.2.213	1	HYDR.SCHLAUCH	CAN.HYDRAULIQUE	HYDR.TUBE		
7	00 415.579	4	O-RING 6.5X1.5	JOINT TORIQUE	O-RING		

PNR	TEILE-NR	MENGE	BENENNUNG	DESIGNATION	DESCRIPTION	BEMERK/REMARQUE	FU
0.01	00	103.54.150.0	1 STEUERPULT ZUS.	PUITRE DE COMMANDE	CONTROL	(1-32)	
1	00	107.54.020.0	1 STEUERPULT SCHW.ZUS.	PUITRE DE COMMANDE	CONTROL		
2	00	487.344	2 TAST-TAST-SCHALTER MIT MITTEL	INTERRUPTEUR	SWITCH		
3	00	487.343	2 RAST-TAST-SCHALTER MIT MITTEL	INTERRUPTEUR	SWITCH		
4	00	417.928	1 VERSCHLUSSTOPFEN F 211	BOUCHON	PLUG		
5	00	487.348	1 DRUCKSCHALTER	MANOSTAT	SWITCH		
6	00	487.234	1 GEGENMUTTER GMP 16	CONTRE-ECROU	COUNTER-NUT		
7	00	487.250	1 KABELVERSCHRAUBUNG MIT SPIRAL	VISSAGE DU CABLE	CABLE CROSS		
8	00	476.202	1 VERSORGUNGSKABEL ZUS.	CABLE DE DISTRIB.	CABLE	(8,30)	
9	00	107.54.022.0	1 BODENBLECH	PLAQUE DE FOND	BOTTOM PLATE		
10	00	116.025	4 BLECHSCHRAUBE 4,2X16 DIN 7971	VIS A TOLE	SHEET METAL SCREW		
11	00	417.912	2 VERSCHLUSSTOPFEN F 4	BOUCHON	PLUG		
12	00	478.010	0 LITZENDRAHT SW 1,5	CABLE TORSADÉ SW 1,5	STRAND OF WIRE SW1,5		
13	00	478.006	0 LITZENDRAHT BLAU 1,5	CABLE TORSADÉ	STRAND OF WIRE		
14	00	475.134	24 FLACHSTECKHUELSE	COSSE POUR FICHE PL.	SOCKET		
15	00	475.011	15 STECKVERTEILER	CONNECTEUR TRIPLE	DISTRIBUTER		
16	00	108.951	2 FLR-SCHRAUBE MIT SCHLITZ M 8	VIS A TETE BOMBEE	FLAT ROUND SCREW	242	
17	00	107.54.013.0	1 WINKEL	CORNIERE	ANGLE		
18	00	107.54.024.0	1 LASCHE	ECLISSE	PLATE		
20	00	495.372	1 AZB „STEUERPULT“	ETIQUETTE	DECAL		
30	00	474.134	1 STECKER 13-POLIG	FICHE	PIN		
40	00	103.57.300.0	1 VERLAENGERUNGSKABEL	CABLE	CABLE	(41-50)	
41	00	477.022	3 OELFLEX-NUMMERNKABEL 12X1,5	CABLE	CABLE		
42	00	474.019	1 STECKDOSE 13-POLIG	PRISE DE COURANT	SOCKET		
43	00	475.102	24 ENDHUELSE	DOUILLE	SLEEVE		
44	00	104.551	3 ZYL-SCHR. M5X30 DIN 84 4.8 ZN	VIS-CYLINDRIQUE	BOLT, SOCKET		
45	00	120.156	3 SK-MUTTER M 5 DIN 934-8	ECROU HEXAGONAL	NUT, HEX.		
46	00	165.307	3 FEDERRING 5 DIN 128, ZN	RONDELLE GROWER	WASHER, SPRING		
47	00	103.57.303.0	1 HALTER	SUPPORT	MOUNTING		
48	00	474.134	1 STECKER 13-POLIG	FICHE	PIN		
49	00	487.239	1 KABELVERSCHRAUBUNG STP 16	VISSAGE DU CABLE	CABLE CROSS		
50	00	487.234	1 GEGENMUTTER GMP 16	CONTRE-ECROU	COUNTER-NUT		

PNR	TEILE-NR	MENGE	BENENNUNG	DESIGNATION	DESCRIPTION	BEMERK/REMARQUE	FU
0.01	00 103.92.100.0	1	AUSRUESTUNG USA	EQUIPEMENT NORMAL	NORMAL HITCH EQUIPM.		
2	00 495.212.0002	1	AZB DANGER ROTATING DRIVE	ETIQUETTE	DECAL		
3	00 495.212.0003	2	AZB DANGER SHIELD MISSING	ETIQUETTE	DECAL		
6	00 495.212.0008	1	AZB DANGER NEVER ALLOW RIDERS	ETIQUETTE	DECAL		
7	00 495.213.0003	1	AZB WARNING BEFORE OPERATING..	ETIQUETTE	DECAL		
8	00 495.213.0009	3	AZB „WARNING...“	ETIQUETTE	DECAL		
9	00 495.213.0012	5	AZB WARNING SHIELD IS..	ETIQUETTE	DECAL		
10	00 495.213.0013	4	AZB WARNING CRUSHING INJURY..	ETIQUETTE	DECAL		
11	00 495.213.0015	4	AZB „WARNING...“	ETIQUETTE	DECAL		
12	00 495.214.0001	1	AZB CAUTION 540RPM	ETIQUETTE	DECAL		
13	00 495.214.0003	5	AZB CAUTION KEEP OFF	ETIQUETTE	DECAL		

CLICK HERE TO **DOWNLOAD** THE COMPLETE MANUAL

- Thank you very much for reading the preview of the manual.
- You can download the complete manual from: [www.heydownloads.com](http://www.heydownloads.com) by clicking the link below



- Please note: If there is no response to CLICKING the link, please download this PDF first and then click on it.

CLICK HERE TO **DOWNLOAD** THE COMPLETE MANUAL