

CLICK HERE TO **DOWNLOAD** THE COMPLETE MANUAL

- Thank you very much for reading the preview of the manual.
- You can download the complete manual from: www.heydownloads.com by clicking the link below



- Please note: If there is no response to CLICKING the link, please download this PDF first and then click on it.

CLICK HERE TO **DOWNLOAD** THE COMPLETE MANUAL

SCHALTPLAN
 SCHEMA DE BRANCHEMENT
 DIAGRAM OF CONNECTIONS

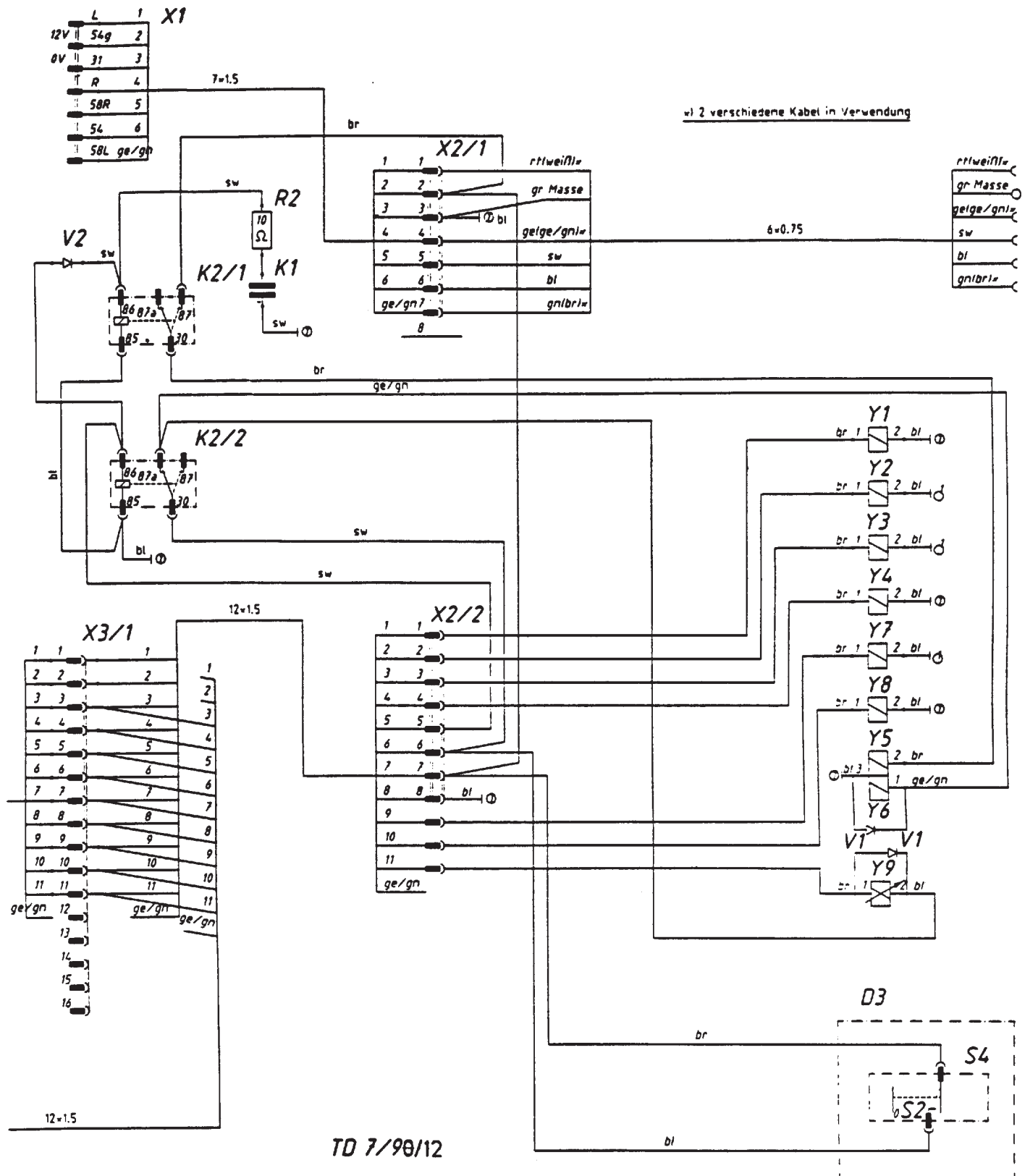

TD 7/98/12

PNR	TEILE-NR	MENGE	BENENNUNG	DESIGNATION	DESCRIPTION	BEMERK/REMARQUE	AB-NR	BIS-NR
0.01	00 517.01.100.1	1	RAHMEN ZUS.	CHASSIS	FRAME	(1-29)	1001	
1	00 517.01.101.1	1	RAHMEN SZ.	CHASSIS	FRAME			2453
1.01	00 517.01.101.2	1	RAHMEN SZ.	CHASSIS	FRAME		2454	
2	00 507.01.021.0	2	KONSOLE	CONSOLE	SUPPORT		1001	
3	00 121.01.113.1	2	KONSOLE RE.	CONSOLE	SUPPORT	R	1001	
4	00 507.01.020.1	2	HOLZLEISTE	LISTEAU	WOODEN BAR		1001	
5	00 548.76.423.0	6	DEHNHUELSE	DOUILLE	SLEEVE		1001	
6	00 102.82.023.0	1	OLJEBRONCEBUECHSE	COUSSINET FRITTE	SINTER BEARING BUSH		1001	
7	00 103.962	6	SK-SCHR. M20X1,5X85	VIS M20X1,5X85	SCREW M20X1,5X85		1001	
8	00 122.220	6	SICHERUNGSM. M20X1,5	ECROU M20X1,5	NUT M20X1,5		1001	
9	00 166.848	6	SCHEIBE 21X37X4	RONDELLE	WASHER		1001	
10	00 103.131	8	SK-SCHR. M16X50 DIN 933-8.8	VIS M16X50 ZN	SCREW M16X50		1001	
11	00 106.153	4	SENKSCRAUBE M10X50	VIS M10X50	BOLT M10X50		1001	
12	00 103.064	8	SK-SCHR. M10X25 DIN 933-8.8	VIS M10X25 ZN	SCREW M10X25		1001	
13	00 122.110	8	SI-MUTTER M16 DIN 980-8	ECROU M16 DIN 980	NUT M16 DIN 980		1001	
14	00 122.107	12	SI-MUTTER M10 DIN 980-8	ECROU M10 DIN 980	NUT M10 DIN 980		1001	
15	00 162.409	8	SCHEIBE 34X16,5X3 ZN	RONDELLE	WASHER		1001	
16	00 162.404	8	SCHEIBE 20X10,5X1,5 ZN	RONDELLE	WASHER		1001	
17	00 126.29.072.0	2	RING	BAQUE	RING		1001	
18	00 135.70.030.1	1	FORMROHR	TUBE FACONNE	SUPPORT		1001	
19	00 102.01.107.0	1	BOLZEN	AXE	PIN		1001	
20	00 102.01.106.0	2	BOLZEN	AXE	PIN		1001	
21	00 103.305	2	SK-SCHR. M10X70 DIN 931-8.8	VIS M10X70 ZN	SCREW M10X70 DIN 931		1001	
22	00 173.504	5	SPANNSTIFT 10X50 DIN 1481	GOUPILLE MECANINDUS	ROLLPIN 10X50		1001	
23	00 172.967	4	SPANNSTIFT 6X50 DIN 1481	GOUPILLE MECANINDUS	ROLLPIN 6X50		1001	
24	00 173.143	4	SPANNSTIFT 6X36 DIN 1481	GOUPILLE MECANINDUS	ROLLPIN 6X36		1001	
25	00 163.101	6	SCHEIBE 35,5/50X2	RONDELLE	WASHER		1001	
26	00 163.105	1	SCHEIBE 30.2 / 50*2	RONDELLE	WASHER		1001	
27	00 166.913	1	SCHEIBE 30,1 X 50 X 1 FED.ST.	RONDELLE	WASHER		1001	
28	00 163.106	5	SCHEIBE 25,2/40X3	RONDELLE	WASHER		1001	
29	00 162.415	9	SCHEIBE 44X25,2X2	RONDELLE	WASHER		1001	

PNR	TEILE-NR	MENGE	BENENNUNG	DESIGNATION	DESCRIPTION	BEMERK/REMARQUE	AB-NR	BIS-NR
76	00	435.364	1 ZUGFEDER	RESSORT DE TRACTION	SPRING			1956
77	00	141.21.023.0	1 BOLZEN	AXE	PIN			1956
78	00	141.21.025.0	1 BOLZEN	AXE	PIN			1956
79	00	141.21.026.0	1 ROHR	TUBE	TUBE			1956
80	00	141.21.030.0	1 NABE	MOYEU	HUB			1956
81	00	141.21.035.0	1 HEBEL	LEVIER	LEVER			1956
82	00	122.110	1 SI-MUTTER M16 DIN 980-8 ZN	ECROU M16 DIN 980	NUT M16 DIN 980			1956
83	00	172.964	1 SPANNSTIFT 5X30 DIN 1481	GOUPILLE MECANINDUS	ROLLPIN			1956
84	00	173.172	1 SPANNSTIFT 8X50 DIN 1481 ZN	GOUPILLE MECANINDUS	ROLLPIN			1956
85	00	157.018	1 SICHERUNGSRING 20X1,2 DIN 471	SEGMENT D'ARRET	CIRCLIP			1956
86	00	153.29.015.0	2 U-BUEGEL SZ.	ETRIER	CROSSTIE	V		1956
87	00	153.29.016.0	1 U-BUEGEL SZ.	ETRIER	CROSSTIE	V		1956
88	00	450.22.045.0	2 LASCHE	ECLISSE	PLATE			1956
89	00	103.068	2 SK-SCHR M10X45 DIN 933-8.8	VIS M10X45	SCREW M10X45			1956
90	00	122.107	2 SI-MUTTER M10 DIN 980-8	ECROU M10 DIN 980	NUT M10 DIN 980			1956
91	00	121.92.010.0	1 WARNDREIECK ZUS.	TRIANGLE DANGER	WARNING BOARD	(21-29		1956
92	00	141.21.020.0	1 RUECKWANDAUSHEBUNG MECH.KPL.	LEVEE DE PAROI ARRI.	REAR WALL LEVY	V FU1:		2616
92.01	00	141.20.205.0	1 RUECKKWAND KPL.	PAROI ARRIERE	REAR WALL	(3-10,13-17,70		2453

FU1: (11,12,18-20,42-55,77-86

FU1: (11,12,18-20,42-55,77-86

FU1: (11,12,18-20,42-55,77-86

PNR	TEILE-NR	MENGE	BENENNUNG	DESIGNATION	DESCRIPTION	BEMERK/REMARQUE	AB-NR	BIS-NR
0.01	00	453.786	2 ACHSE SPUR 2020	PONT	AXLE	(1-25)	2116	2616
1	00	453.205	4 VERSCHLUSSKAPPE	CAPUCHON DE FERMET.	SEALING-CAP		2116	2616
2	00	175.068	4 SPLINT 5X50 DIN 94	GOUPILLE FENDUE	COTTERPIN		2116	2616
3	00	121.512	4 FL.KRONENM. M24X1,5 DIN937	CRENEAUX PLAT	CROWN NUT		2116	2616
4	00	453.452	4 BEILAGSCHEIBE 60X30X4	RONDELLE	WASHER		2116	2616
5	00	404.568	4 KEGELROLLENLAGER 32208	ROULEM.A ROUL.CONI.	TAPER ROLLER BEARING		2116	2616
6	00	453.158.001	4 BREMSTROMMEL 300X80 H=130MM	TAMBOUR DE FREIN	BRAKE DRUM		2116	2616
7	00	127.003	24 KUGELBUNDM. M 18X1,5 DIN 74361	ECROU A EMBASE	WHEEL NUT		2116	2616
8	00	453.226	24 RADBOLZEN M 18X1,5X62	BOULON DE ROUE	WHEEL BOLT		2116	2616
9	00	404.571	4 KUGELLAGER 32211	ROULEMENT A BILLES	BEARING, BALL		2116	2616
10	00	453.463	4 LAGERABDECKSCHEIBE 100X55	DISQUE	BEARING COVER		2116	2616
11	00	453.459	4 SCHEIBE 90X55	RONDELLE	WASHER		2116	2616
12	00	453.257	4 BACKENBOLZEN KPL.	AXE	BOLT		2116	2616
13	00	453.616	4 BREMSBACKE BEWEGL. ASBESTFREI	MACHOIRE DE FREIN	BRAKE CHEEK		2116	2616
14	00	453.670	8 RUECKSTELLFEDER	RESSORT	SPRING		2116	2616
15	00	453.619	4 BREMSBACKE STARR ASBESTFREI	MACHOIRE DE FREIN	BRAKE CHEEK		2116	2616
16	06	85A03	2 BREMSNOCKENWELLE L=440	ARBRE	SHAFT		2116	2616
17	06	85A09	2 BREMSNOCKENWELLE L=1340	ARBRE	SHAFT		2116	2616
18	00	453.671	4 ZUGFEDER	RESSORT DE TRACTION	SPRING		2116	2616
19	00	453.672	2 ZUGFEDER MIT AUSNEHMUNG RECHTS	RESSORT DE TRACTION	SPRING		2116	2616
19.01	00	453.673	2 ZUGFEDER MIT AUSNEHMUNG LINKS	RESSORT DE TRACTION	SPRING		2116	2616
20	00	453.453	4 BEILAGSCHEIBE - NOCKE	RONDELLE	WASHER		2116	2616
21	00	453.617	4 FALTENBALG	SOUFFLET	BELLOWS		2116	2616
22	06	00158.2	4 BREMSHEBEL KPL.	LEVIER DE FREIN	BRAKE LEVER		2116	2616
23	00	453.271	2 AUSGLEICHSWAAGE	ELEMENT COMP.BASC.	ADJUSTING LEVEL		2116	2616
25	00	453.618	4 BREMSBACKENTRAEGER	SUPPORT	BRACKET		2116	2616

PNR	TEILE-NR	MENGE	BENENNUNG	DESIGNATION	DESCRIPTION	BEMERK/REMARQUE	AB-NR	BIS-NR
0.01	00 141.36.000.1	1	BREMSANLAGE HYDR.FUER EINZELA.	DISPOS. DE FREINAGE	BRAKE DEVICE	(1-22)	1001	2518
1	00 442.181	2	BREMSZYLINDER	CYLIN. DE FREIN	BRAKE CYLINDER			2518
1.01	00 442.101	2	DICHTUNGSSATZ	GARNITURE DE JOINTS	SET OF GASKETS			2518
2	00 442.425	1	HYDRAULIK-ZYLINDER 45-30-100	VERIN HYDRAULIQUE	HYDR.CYLINDER			1850
2.01	00 442.345.001	1	DICHTSATZ	JEU DE JOINTS	SET OF GASKETS		1851	
3	00 103.39.000.1	1	ZUSATZ F. TANDEM KPL.	ADDITION P.	ADDITION F.	(1,2,5-9,17,19,23-25)	1001	2518
4	00 103.36.009.0	1	LASCHE	ECLISSE	PLATE		1001	2518
5	00 122.108	4	SI-MUTTER M12 DIN 980-8 ZN	ECROU M12 DIN 980-8	NUT M12 DIN 980-8		1001	2518
6	00 103.127	4	SK-SCHR. M16X30 DIN933-8.8 ZN	VIS M16X30	SCREW M16X30		1001	2518
7	00 122.110	2	SI-MUTTER M16 DIN 980-8 ZN	ECROU M16 DIN 980	NUT M16 DIN 980		1001	2518
8	00 103.088	4	SK-SCHR. M12X40 DIN 933-8.8	VIS M12X40	SCREW M12X40		1001	2518
9	00 103.36.010.0	4	LASCHE	ECLISSE	PLATE		1001	2518
10	00 447.4.209	1	HYDR.SCHLAUCH	CAN.HYDRAULIQUE	HYDR.TUBE	(35)		1850
10.01	00 447.1.284	1	HYDR.SCHLAUCH NW 8 X 5850 DIN	TUYAU NW 6X1100	TUBE NW 6X1100	(38)	1851	
11	00 448.236	1	EINSCHRAUBVERSCHRAUBUNG GERADE	RACCORD	BOLTED JOINT STRAIGH		1001	2518
12	00 448.203	1	STECKMUFFE	DOUILLE	BOX		1001	2518
14	00 141.36.008.0	1	LEITUNG 8X1,5 L-2200	CONDUITE	OVERFLOW PIPE			1850
14.01	00 141.36.008.1	1	ROHRLEITUNG 10X1,5 L=2200	CONDUITE	HYDR. PIPE		1851	
15	00 448.422	1	WINKELVERSCHRAUBUNG	RACCORD FILETE COUDE	CONNECTING SCREW		1001	2518
16	00 447.3.204	1	HYDR.SCHLAUCH	CAN.HYDRAULIQUE	HYDR.TUBE		1001	2518
20	00 448.558	2	SCHLAUCHSCHELLE 19,0	BRIDE	CLAMP		1001	2518
21	00 118.111	4	BOHR-SCHRAUBE 5,5X16	VIS 5,5X16	SCREW 5,5X16		1001	2518
22	00 162.405	2	SCHEIBE 18X6,5X1,5	RONDELLE	WASHER		1001	2518
23	00 135.77.005.0	1	BOLZEN	AXE	PIN		1001	2518
24	00 448.1.271	1	T-VERSCHRAUBUNG	PAPILLON	THROTTLE VALVE		1001	2518
25	00 447.2.202	1	HYDR.SCHLAUCH NW6 L=1200	TUYAU L=1200	TUBE L=1200		1001	2518
27	00 448.703	3	BEFESTIGUNGSSCHELLE	COLLIER	CLIP		1001	2518
28	00 110.102	3	SK-HOLZSCHRAUBE M6X25 DIN571	VIS A BOIS HEXAGONAL	WOOD-SCREW		1001	2518
30	00 453.271	2	AUSGLEICHSWAAGE	ELEMENT COMP.BASC.	ADJUSTING LEVEL		1001	2518
31	00 106.155	1	SENKSCHEIBE M10X70 DIN991-8	VIS A TETE 6 PANS	HEXAGON BOLT		1001	2518
32	00 122.107	1	SI-MUTTER M10 DIN 980-8	ECROU M10 DIN 980	NUT M10 DIN 980		1001	2518
33	00 162.404	1	SCHEIBE 20X10,5X1,5 ZN	RONDELLE	WASHER		1001	2518
34	00 475.165	2	KABELBINDER 4,8X188	ATTACHE-CABLE	STRIP		1001	2518
35	00 415.579	8	O-RING 6.5X1.5	JOINT TORIQUE	O-RING		1001	2518
36	00 448.005	2	UEBERWURFMUTTER AL 8 DIN 3870	ECROU-CHAPEAU	NUT		1001	2518
37	00 448.006	2	SCHNEIDRING L 8 DIN 3861	FILIERE	RING		1001	2518
38	00 415.577	2	O-RING 7,5X1,5	JOINT TORIQUE	O-RING		1001	2518

PNR	TEILE-NR	MENGE	BENENNUNG	DESIGNATION	DESCRIPTION	BEMERK/REMARQUE	AB-NR	BIS-NR
0.01	00 121.35.000.0	1	HANDBREMSE KPL.	FREIN A MAIN	HAND BRAKE RED	(1-19	1001	
1	00 870.010	1	STELLHEBEL	LEVIER DE REGLAGE	LEVER		1001	
2	00 431.856	1	STAHLDRAHTSEIL MIT KAUSCHE	CABLE DE FIL D'ACIER	STEEL WIRE CABLE	@6000	1001	
3	00 121.35.002.0	1	HALTER	SUPPORT	SUPPORT		1001	
4	00 430.980	1	SEILKAUSCHE A 5 DIN 6899	COSSE POUR CABLE	THIMBLE		1001	
5	00 430.953	3	DRAHTSEILKLEMME 6,5 DIN 741	SERRE CABLE METAL.	WIRE CABLE CLAMP		1001	
6	00 121.35.006.0	1	BUEGEL	POIGNEE	HANDLET		1001	
7	00 432.524	1	BOWDENZUGHUELLE L=470	BOWDEN-CABLE	BOWDEN CABLE		1001	
8	00 122.108	1	SI-MUTTER M12 DIN 980-8 ZN	ECROU M12 DIN 980-8	NUT M12 DIN 980-8		1001	
9	00 103.064	5	SK-SCHR. M10X25 DIN 933-8.8 ZN	VIS M10X25	SCREW M10X25		1001	
10	00 122.107	10	SI-MUTTER M10 DIN 980-8	ECROU M10 DIN 980	NUT M10 DIN 980		1001	
11	00 103.304	6	SK-SCHR. M10X65 DIN 931-8.8	VIS M10X65	SCREW M10X65		1001	
17	00 100.73.105.0	3	SEILROLLE	POULIE GUIDE-CABLE	PULLEY		1001	
18	00 162.401	3	SCHEIBE 26X16,1X1	RONDELLE	WASHER		1001	
19	00 155.014	3	SICHERUNGSRING 16X1 DIN 471	SEGMENT D'ARRET	CIRCLIP		1001	
20	00 103.324	1	SK-SCHR. M12X60 DIN 931-8.8	VIS M12X60	SCREW M12X60		1001	
21	00 162.416	1	SCHEIBE 13*2	RONDELLE	WASHER		1001	
22	00 135.70.040.1	1	BEDIENUNGSKONSOLE	CONSOLE DE COMMANDE	CONSOLE		1001	
23	00 121.35.010.0	1	WINKEL	CORNIERE	ANGLE		1001	

PNR	TEILE-NR	MENGE	BENENNUNG	DESIGNATION	DESCRIPTION	BEMERK/REMARQUE	AB-NR	BIS-NR
94	00	166.810	8 SCHEIBE 65X40,2X2	RONDELLE	WASHER		2006	
95	00	120.160	1 SK-MUTTER M10 DIN 934-8 ZN	ECROU M10 DIN 934-8	NUT M10 DIN 934-8		2006	
99	00	102.40.367.0	1 HEBEL	LEVIER	LEVER		2006	
103	00	103.40.333.0	1 LASCHE	ECLISSE	PLATE		2006	
104	00	438.043	1 ROHRKLAPPSTECKER 8X50	AGRAFE 8X50	SAFETY PIN 8X50		2006	
105	00	139.40.320.0	1 WINKELTRAEGER	SUPPORT	BRACKET		2006	
106	00	103.041	2 SK-SCHR. M8X16 DIN 933-8.8	VIS M8X16	SCREW M8X16		2006	
107	00	435.755	16 FEDERLASCHE	JUMELLE DE RESSORT	SPRING SHACKLE			2453
107.01	00	507.41.009.0	16 BOLZEN	AXE	PIN		2454	
108	00	435.749	16 FEDERLASCHE	JUMELLE DE RESSORT	SPRING SHACKLE			2453
108.01	00	507.41.010.0	16 LASCHE	ECLISSE	PLATE		2454	
109	00	122.316	64 SK-MUTTER M. FLANSCH M6	ECROU M6	NUT M6		2006	
110	00	162.405	64 SCHEIBE 18X6,5X1,5	RONDELLE	WASHER		2006	
111	00	108.165	64 FLR-SCHR. M 6X16 DIN 603-4.6	VIS M 6X16	BOLT M 6X16			2453
111.01	00	435.773	16 FEDERBUEGEL	ETRIER RESSORT	CURVED SPRING		2454	
112	00	140.40.025.0	1 Klappe	TRAPPE	FLAP			2453
112.01	00	517.40.085.0	1 ABDECKUNG SZ.	GROUPE COUVERCLE	COVER		2454	
113	00	118.017	2 SK-SCHRAUBE M10X30	VIS M10X30	SCREW M10X30		2006	
115	00	435.174	16 DRUCKFEDER	RESSORT DE PRESSION	SPRING		2454	
116	00	435.773	16 FEDERBUEGEL	ETRIER RESSORT	CURVED SPRING		2454	

FU1: (14,16-20,22-25,27,77,78

FU1: (14,16-20,22-25,27,77,78

FU1: (14,16-20,22-25,27,77,78

FU2: (15-20,22-24,26,27,77,78

FU2: (15-20,22-24,26,27,77,78

FU2: (15-20,22-24,26,27,77,78

FU3: (34,36,55,72,73,90,91

FU3: (34,36,55,72,73,90,91

FU3: (34,36,55,72,73,90,91

PNR	TEILE-NR	MENGE	BENENNUNG	DESIGNATION	DESCRIPTION	BEMERK/REMARQUE	AB-NR	BIS-NR
0.01	00 103.59.000.0	1	PU-TASTRAEDER LUFTBEREIFT	PU-ROUE PALPEUSE	PU-GROUND WHEEL	(2,7	1001	2616
1	00 103.50.126.1	1	RADTRAEGER LI.	SUPPORT DE ROUE	WHEEL SUPPORT	L	1001	2616
2	00 103.50.125.1	1	RADTRAEGER LI.	SUPPORT DE ROUE	WHEEL SUPPORT	(1-13 L	1001	2616
3	00 203.33.005.0	1	DECKSCHEIBE	DISQUE DE RECOUVREM.	WASHER		1001	2616
4	00 451.552	1	LABYRINTHDICHTUNG	JOINT	GASKET		1001	2616
5	00 543.004	1	OMNIFIT M100 SPEZIAL	PATE FREINAGE D'VIS	SCREW LOCKING PASTE		1001	2616
6	00 162.408	1	SCHEIBE 30X13X5 DIN1542	RONDELLE	WASHER		1001	2616
7	00 103.50.130.1	1	RADTRAEGER RE.	SUPPORT DE ROUE	WHEEL SUPPORT	(13,21-32 R	1001	2616
8	00 451.533	1	RADKAPPE	COUVERCLE	CAP		1001	2616
9	00 103.50.129.0	1	STREBE LI.	JAMBE DE FORCE GAUCH	STRUT LEFT	L	1001	2616
10	00 162.401	1	SCHEIBE 26X16,1X1	RONDELLE	WASHER		1001	2616
11	00 173.116	1	SPANNSTIFT 5X24 DIN 1481	GOUPILLE MECANINDUS	ROLLPIN		1001	2616
12	00 191.002	1	KEGELSCHM. AM 8X1	RACCORD DE GRAISSAGE	GREASING NIPPLE		1001	2616
13	00 500.0.080	2	BEREIFUNG 15X6,0-6 KPL.	PNEUS	TYRES CPTE.	(35-39	1001	2616
21	00 103.50.131.1	1	RADTRAEGER RE.	SUPPORT DE ROUE	WHEEL SUPPORT	R	1001	2616
23	00 203.33.005.0	1	DECKSCHEIBE	DISQUE DE RECOUVREM.	WASHER		1001	2616
24	00 451.552	1	LABYRINTHDICHTUNG	JOINT	GASKET		1001	2616
25	00 543.004	1	OMNIFIT M100 SPEZIAL	PATE FREINAGE D'VIS	SCREW LOCKING PASTE		1001	2616
26	00 162.408	1	SCHEIBE 30X13X5 DIN1542	RONDELLE	WASHER		1001	2616
28	00 451.533	1	RADKAPPE	COUVERCLE	CAP		1001	2616
29	00 103.50.135.0	1	STREBE RE.	JAMBE DE FORCE DROIT	STRUT RIGHT	R	1001	2616
30	00 162.401	1	SCHEIBE 26X16,1X1	RONDELLE	WASHER		1001	2616
31	00 173.116	1	SPANNSTIFT 5X24 DIN 1481	GOUPILLE MECANINDUS	ROLLPIN		1001	2616
32	00 191.002	1	KEGELSCHM. AM 8X1	RACCORD DE GRAISSAGE	GREASING NIPPLE		1001	2616
35	00 451.554	2	FELGE MIT NABE 4,50X6	JANTE DE ROUE	WHEEL RIM	(38	1001	2616
36	00 452.071	2	REIFEN 15X6,0-6 6 PR	PNEUMATIQUE 15X6,0-6	TYRE 15X6,0-6		1001	2616
37	00 452.514	2	SCHLAUCH 15X6.00-6	TUYAU	HOSE		1001	2616
38	00 400.218	4	RILLENKUGELL. 6205-2Z DIN625	ROUL. RAINURE A BIL.	BEARING		1001	2616
39	00 103.086	2	SK-SCHR. M12X30 DIN 933-8.8 ZN	VIS M12X30	SCREW M12X30		1001	2616

PNR	TEILE-NR	MENGE	BENENNUNG	DESIGNATION	DESCRIPTION	BEMERK/REMARQUE	AB-NR	BIS-NR
0.01	00 122.50.005.0	1	PICK-UP-TROMMEL KPL.	TAMBOUR DU PICK-UP	PICK-UP-REEL	(1-53	1001	1900
1	00 122.50.050.0	1	JOCH	TRAVEE	SUPPORT		1001	1900
2	00 122.50.025.0	2	STIRNSCHEIBE	RONDELLE D'EXTREMITÉ	BEARING PLATE		1001	1900
3	00 122.50.055.0	1	WELLE	ARBRE	SHAFT		1001	1900
4	00 103.043	2	SK-SCHRAUBE M8X20 - DIN 933	VIS	SCREW		1001	1900
5	00 120.109	2	SK-MUTTER M 8 DIN 934-8	ECROU M 8 DIN 934	NUT M 8 DIN 934		1001	1900
6	00 122.50.016.0	4	ZINKENROHR	TUBE PORTE-DENTS	TINE TUBE			1680
6.01	00 122.50.016.1	4	ZINKENROHR	TUBE PORTE-DENTS	TINE TUBE		1681	
7	00 436.138	52	FEDERZINKE	DENT A RESSORT	SPRING TINE		1001	1900
8	00 122.50.018.0	16	FLANSCHGEHÄUSE	BRIDE POUR CARTER	FLANGE HOUSING		1001	1900
9	00 624.086	16	LAGERHAELFTE	MOITIE DE COUSSINET	HALF BEARING		1001	1900
10	00 156.201	4	SEGER-GREIFRING G14X1,5	CIRCLIP	SAFETY RING			1680
11	00 166.838	4	SCHEIBE 14.2/29X2	RONDELLE	WASHER			1680
12	00 122.50.023.0	4	BUCHSE	DOUILLE	BUSH			1680
13	00 122.50.014.0	8	SCHEIBE	RONDELLE	WASHER		1001	1900
14	00 108.906	52	FLR-SCHRAUBE M8X50 DIN603-8.8	VIS A TETE BOMBEE	FLAT ROUND SCREW		1001	1900
15	00 100.05.007.0	52	KAPPE	CAPUCHON	CAP		1001	1900
16	00 122.106	52	SI-MUTTER M8 DIN 980-8	ECROU M8 DIN 980	NUT M8 DIN 980		1001	1900
17	00 122.50.019.0	4	DISTANZPROFIL	PROFIL	PROFILE		1001	1900
18	00 108.805	16	FLR.-SCHR.M8X16 DIN603-8.8	VIS A TETE BOMBEE	FLAT ROUND BOLT		1001	1900
19	00 122.056	16	SICHERUNGSMUTTER M8 DIN 980-8	ECROU „STOVER“	LOCK NUT		1001	1900
20	00 122.50.062.0	2	PASSFEDER A10X8X40	CLAVETTE	KEY		1001	1900
21	00 122.50.015.0	4	ZINKENROHR KPL.	TUBE PORTE-DENTS	TINE TUBE			1680
22	00 122.50.058.0	23	ABSTREIFER	DÉFLECTEUR	SCRAPER		1001	1900
23	00 122.50.056.1	1	DISTANZROHR	TUBE	TUBE		1001	1900
24	00 166.445	2	SCHEIBE 31/45X1	RONDELLE	WASHER		1001	1900
25	00 155.026	1	SICHERUNGSRING 30X1,5 DIN471	SEGMENT D'ARRET	CIRCLIP		1001	1900
26	00 122.50.030.0	1	STIRNBLECH LI.	TOLE GAUCHE	PLATE LEFT	L	1001	1900
27	00 122.50.045.0	1	STEUERSCHEIBE KPL.	DISQUE	DISC		1001	1900
28	00 122.50.046.0	1	SCHEIBE I	RONDELLE	WASHER		1001	1900
29	00 122.50.047.0	2	SCHEIBE II	RONDELLE	WASHER		1001	1900
30	00 106.053	3	SENKSCHRAUBE M10X50 DIN7991	VIS A TETE 6 PANS	HEXAGON BOLT		1001	1900
31	00 165.311	3	FEDERRING A10 - DIN 128	RONDELLE	WASHER		1001	1900
32	00 120.110	3	SK-MUTTER M 10 DIN 934-8	ECROU M 10	NUT M 10		1001	1900
33	00 122.50.015.1	4	ZINKENROHR KPL.	TUBE PORTE-DENTS	TINE TUBE	(6-17,55-60	1681	
34	00 406.071	1	FLANSCHLAGER INA RRTY 30	PALIER A BRIDE	FLANGE BEARING		1001	1900
35	00 191.002	1	KEGELSCHM. AM 8X1	RACCORD DE GRAISSAGE	GREASING NIPPLE		1001	1900
36	00 122.50.039.0	1	DECKEL	COUVERTURE	COVER		1001	1900
37	00 118.009	1	SK-SCHR. M8X16	VIS M8X16	SCREW M8X16		1001	1900
38	00 122.50.035.0	1	STIRNBLECH RE.	TOLE DROITE	PLATE RIGHT	R	1001	1900
39	00 122.50.038.0	1	SCHEIBE	RONDELLE	WASHER		1001	1900
40	00 108.143	2	FLR.SCHR. M 10X25 DIN 603-8.8	VIS M 10X25	SCREW M 10X25		1001	1900
41	00 165.011	2	FEDERRING 10 DIN 128	BAGUE 10 DIN 128	WASHER 10 DIN 128		1001	1900
42	00 120.110	2	SK-MUTTER M 10 DIN 934-8	ECROU M 10	NUT M 10		1001	1900
43	00 122.50.059.0	25	STUETZE	SUPPORT	SUPPORT		1001	1900
45	00 162.889	4	SCHEIBE 10.5/43X6	RONDELLE	WASHER		1001	1900
46	00 122.50.057.0	1	ABSTREIFER LI.	DÉFLECTEUR	SCRAPER	L	1001	1900
47	00 122.50.054.0	2	ABSTREIFER AUSSEN	DÉFLECTEUR	SCRAPER		1001	1900
49	00 118.009	52	SK-SCHR. M8X16	VIS M8X16	SCREW M8X16		1001	1900
50	00 100.061	2	SK-SCHRAUBE M10X16 DIN 933-8.8	VIS	SCREW		1001	1900
51	00 165.011	4	FEDERRING 10 DIN 128	BAGUE 10 DIN 128	WASHER 10 DIN 128		1001	1900
52	00 100.063	2	SK-SCHRAUBE M10X20 DIN 933-8.8	VIS	SCREW		1001	1900
53	00 122.50.096.0	4	AUFSPANNBUCHSE AS20/14X22	DOUILLE	BUSH			1680
54	00 406.065	1	2-LOCHFLANSCHLAGER INA RATY 30	PALIER A BRIDE	FLANGE BEARING		1001	1900
55	00 401.912	4	LAUFROLLE	POULIE	ROLLER		1681	
56	00 162.520	4	SCHEIBE 20X12,2X1,5	RONDELLE	WASHER		1681	
57	00 155.010	4	SICHERUNGSRING 12X1 DIN 471	SEGMENT D'ARRET	CIRCLIP		1681	
60	00 108.918	4	FLR-SCHR. M 8X55 DIN 603-8.8	VIS A TETE BOMBEE	BOLT, SLOTTED		1001	1900

PNR	TEILE-NR	MENGE	BENENNUNG	DESIGNATION	DESCRIPTION	BEMERK/REMARQUE	AB-NR	BIS-NR
101	00	103.305	2 SK-SCHR. M10X70 DIN 931-8.8 ZN	VIS M10X70 DIN 931	SCREW M10X70 DIN 931		1001	
103	00	162.766	3 SCHEIBE 40X25,2X3	RONDELLE	WASHER		1001	
104	00	101.529	4 SK-SCHRAUBE M20X1,5X50 DIN 933	VIS	SCREW		1001	
108	00	122.120	4 SICHERUNGSMUTTER M20X1,5	ECROU „STOVER“	LOCK NUT		1001	
109	00	448.1.051	2 REDUZIERSTUTZEN	REDUCTION RACCORD	REDUCTION SOCKET		1001	
110	00	447.2.204	1 HYDR. SCHLAUCH NW6X400	LIFT DE HYDRAULIQUE	HYDRAULIC LIFT		1001	
111	00	448.005	1 UEBERWURFMUTTER AL 8 DIN 3870	ECROU-CHAPEAU	NUT		1001	
112	00	448.006	1 SCHNEIDRING L 8 DIN 3861	FILIERE	RING		1001	
113	00	415.579	3 O-RING 6.5X1.5	JOINT TORIQUE	O-RING		1001	
114	00	415.577	1 O-RING 7,5X1,5	JOINT TORIQUE	O-RING		1001	
118	00	135.70.022.1	2 BOLZEN	AXE	PIN			1850
118.01	00	102.01.106.0	2 BOLZEN	AXE	PIN		1851	
119	00	135.72.030.1	2 ZWISCHENSTUECK	PIECE INTEMEDIAIRE	INTERMEDIATE PIECE		1001	
120	00	126.29.072.0	2 RING	BAQUE	RING		1851	
121	00	126.40.043.0	2 RIPPE	NERVURE	BAR		1001	
122	00	135.70.049.0	1 BOLZEN	AXE	PIN		1001	
122.01	00	102.01.107.0	1 BOLZEN	AXE	PIN		1851	
123	00	121.78.001.0	1 ZUGOESE DREHBAR	ANNEAU D'ATTELAGE	TOWING EYE		1001	
130	00	135.71.021.0	2 VERLAENGERUNG	RALLONGE	EXTENSION		1001	
131	00	103.169	4 SK-SCHR. M20X50 DIN 933-8.8 ZN	VIS A TET 6 PANS	SCREW, HEX.HD.		1001	
132	00	122.112	4 SI-MUTTER M20 DIN 980 8	ECROU M20	NUT M20		1001	

FU1: (7-9,23-25,31,48-51,81-101,19-112
FU1: (7-9,23-25,31,48-51,81-101,19-112
FU1: (7-9,23-25,31,48-51,81-101,19-112

FU2: (49-55,61,104,108,119-121
FU2: (49-55,61,104,108,119-121
FU2: (49-55,61,104,108,119-121

FU3: (15.01-17.01,62.01,63.011
FU3: (15.01-17.01,62.01,63.011
FU3: (15.01-17.01,62.01,63.011

CLICK HERE TO **DOWNLOAD** THE COMPLETE MANUAL

- Thank you very much for reading the preview of the manual.
- You can download the complete manual from: www.heydownloads.com by clicking the link below



- Please note: If there is no response to CLICKING the link, please download this PDF first and then click on it.

CLICK HERE TO **DOWNLOAD** THE COMPLETE MANUAL

PNR	TEILE-NR	MENGE	BENENNUNG	DESIGNATION	DESCRIPTION	BEMERK/REMARQUE	AB-NR	BIS-NR
0.01	00	451.224	1 STUETZRAD KPL.	ROULETTE D'APPUI	JOCKEY WHEEL CPTÉ.	(1-18)	1001	
1	00	451.380	1 AUSSENROHR	TUBE EXTERIEURE	TUBE		1001	
2	00	451.367	1 INNENROHR	TUBE INTERIEURE	TUBE		1001	
3	00	451.338	1 GEWINDESPINDEL TR. 28X4	PIVOT	SPINDLE		1001	
4	00	451.324	1 GUSSMUTTER 28X4	ECROU EN FONTE	NUT		1001	
5	00	173.144	1 SPANNSTIFT 6X40 DIN 1481	GOUPILLE MECANINDUS	ROLLPIN 6X40		1001	
6	00	172.160	2 SPANNSTIFT 8X16 DIN 1481	GOUPILLE MECANINDUS	ROLLPIN		1001	
7	00	403.004	1 AXIAL-KUGELLAGER 51104 DIN 711	BUTÉE A BILLES	BALL BEARING		1001	
8	00	162.765	1 SCHEIBE 50X20,2X3	RONDELLE	WASHER		1001	
9	00	451.363	1 HANDKURBEL	MANIVELLE	HAND CRANK		1001	
10	00	172.141	1 SPANNSTIFT 6X30 DIN 1481	GOUPILLE MECANINDUS	ROLLPIN		1001	
11	00	451.326	1 LAUFRAD	ROUE DE SUPPORT	WHEEL		1001	
12	00	451.327	2 LAGERBUECHSE	COUSSINET	BUSH		1001	
13	00	451.328	1 RADBOLZEN	BOULON DE ROUE	WHEEL BOLT		1001	
14	00	175.068	1 SPLINT 5X50 DIN 94	GOUPILLE FENDUE	COTTERPIN		1001	
15	00	451.330	1 GRIFF	POIGNEE	HANDLE		1001	
16	00	103.01.080.0	1 BOLZEN	AXE	PIN		1001	
17	00	172.148	1 SPANNSTIFT 6X60 DIN 1481	GOUPILLE MECANINDUS	ROLLPIN		1001	
18	00	162.513	1 SCHEIBE 60X31X1,5	RONDELLE	WASHER		1001	
19	00	435.124	1 DRUCKFEDER	RESSORT DE PRESSION	SPRING		1001	
20	00	103.01.082.0	1 EXZENTER	EXCENTRIQUE	ECCENTRIC		1001	
21	00	172.201	1 SPANNSTIFT 10X60 DIN 1481	GOUPILLE MECANINDUS	ROLLPIN		1001	
22	00	103.01.081.0	1 SICHERUNGSSTANGE	BARRE DE SECURITE	LOCKING BAR		1001	
23	00	162.601	1 SCHEIBE 18X8,5X2	RONDELLE	WASHER		1001	
24	00	175.037	1 SPLINT 3,2X16 DIN 94	GOUPILLE FENDUE	COTTERPIN		1001	

PNR	TEILE-NR	MENGE	BENENNUNG	DESIGNATION	DESCRIPTION	BEMERK/REMARQUE	AB-NR	BIS-NR
0.01	00 517.50.250.0	1	PRALLBLECH MIT ROLLE	CHICANE	INTAKE PLATE	(1-22)	2678	
1	00 517.50.240.0	1	PRALLBLECH SZ.	CHICANE	INTAKE PLATE		2678	
2	00 517.50.245.0	1	ROLLE SZ	GALET	ROLLER		2678	
3	00 548.50.265.1	2	LAGERPLATTE SZ.	PLAQUE D'APPUI	PLATE		2678	
4	00 563.50.261.0	1	HAKEN SZ.	CROCHET	HOOK		2678	
5	00 103.045	1	SK-SCHR. M8X30 DIN 933-8.8	VIS M8X30	SCREW M8X30		2678	
6	00 103.066	4	SK-SCHR. M 10X35 DIN 933-8.8	VIS M 10X35	SCREW M 10X35		2678	
7	00 103.869	1	SK-SCHRAUBE M10X170 DIN 931	8 VIS	SCREW		2678	
8	00 122.107	1	SI-MUTTER M10 DIN 980-8	ECROU M10 DIN 980	NUT M10 DIN 980		2678	
9	00 122.317	3	FLANSMUTTER M8	ECROU M8	NUT M8		2678	
10	00 162.415	4	SCHEIBE 44X25,2X2	RONDELLE	WASHER		2678	
11	00 162.416	2	SCHEIBE 13*2	RONDELLE	WASHER		2678	
12	00 162.445	1	SCHEIBE 10,5/43X4	RONDELLE	WASHER		2678	
13	00 162.448	2	SCHEIBE 8,5/24X2,5	RONDELLE	WASHER		2678	
14	00 163.132	2	SCHEIBE 30X20,5X1,5	RONDELLE	WASHER		2678	
15	00 168.051	2	SPANNSCHEIBE 12	BAGUE 12	RING 12		2678	
16	00 175.252	2	SPLINT 4X25 DIN 94	GOUPILLE FENDUE	COTTERPIN 4X25		2678	
17	00 400.169	2	RILLKLAG. 6004 2RS DIN 625	ROULEMENT A ROULEAUX	BEARING, BALL		2678	
18	00 417.442	2	VERSCHLUSSDECKEL 42X9,5	COUVERTURE GAUCHE	COVER LEFT		2678	
19	00 435.138	1	DRUCKFEDER	RESSORT DE PRESSION	SPRING		2678	
20	00 459.035	2	ANSCHLAGPUFFER	BUTEE	STOP		2678	
21	00 464.251	1	RUNDGLIEDERKETTE G5X35 DIN 568	CHAINE MAILL. RONDS	ROUND LINK CHAIN		2678	
22	00 543.004	1	OMNIFIT M100 SPEZIAL	PATE FREINAGE D'VIS	SCREW LOCKING PASTE	0,100 CCM	2678	

PNR	TEILE-NR	MENGE	BENENNUNG	DESIGNATION	DESCRIPTION	BEMERK/REMARQUE	AB-NR	BIS-NR
0.01	00 502.80.003.0	1	EINGANGSGETRIEBE KPL.	TRANSMISS. D'ENTREE	INPUT TRANSMISSION	(1-31	1001	
1	00 126.80.008.1	1	GETRIEBEGEHAUSE	CARTER B. A VITESSE	GEAR HOUSING		1001	
2	00 502.80.008.0	1	WELLE	ARBRE	SHAFT		1001	
3	00 126.80.009.0	1	GETRIEBEBECKEL	COUVERCLE	COVER		1001	
4	00 115.08.013.0	1	DICHTUNG	JOINT	SEAL		1001	
5	00 415.120	1	WELLENDICHRING 40X68X10	BAGNE D ETANCHEITE	OIL SEAL		1001	
6	00 400.225.001	2	RILLENKUGELLAGER 6208 DIN 625	ROULEM.DE BUTEE 6208	BEARING 6208	648	1001	
7	00 166.546	5	PASSSCHEIBE 40/50X0,3 DIN 988	RONDELLE 40/50X0,3	WASHER 40/50X0,3		1001	
8	00 150.536	1	PASSFEDER AB 12X8X56 DIN 6885	CLAVETTE	KEY		1001	
9	00 400.325.001	1	RILLENKUGELLAGER 6308 DIN 625	ROULEM.DE BUTEE	BEARING	648	1001	
10	00 415.122	1	WELLENDICHRING A 40X80X10	BAGNE D ETANCHEITE	OIL SEAL		1001	
11	00 126.80.110.0	1	RITZEL Z=12	PIGNON	PINION		1001	
12	00 502.80.009.0	1	ROHR	TUBE	TUBE		1001	
13	00 141.84.092.0	1	BUECHSE LT.	BAGUE	BUSH	L	1001	
14	00 415.175	1	WELLENDICHRING 55X80X10	BAGNE D ETANCHEITE	OIL SEAL		1001	
15	00 126.80.014.0	1	DISTANZRING	BAGUE	RING		1001	
16	00 415.388	1	O-RING 40X2,5	JOINT TORIQUE	O-RING		1001	
17	00 166.586	4	PASS-SCHEIBE	RONDELLE	WASHER		1001	
18	00 400.327	1	KUGELLAGER 6308 2Z DIN 625	ROULEMENT A BILLES	BEARING, BALL		1001	
19	00 155.154	1	SICHERUNGSRING 90X3 DIN 472	SEGMENT D'ARRET	CIRCLIP		1001	
20	00 162.769	1	SCHEIBE 65X40,2X3	RONDELLE	WASHER		1001	
21	00 155.032	2	SICHERUNGSRING 40X1,75 DIN471	SEGMENT D'ARRET	CIRCLIP		1001	
22	00 126.80.111.0	1	TELLERRAD Z=34	COURONNE DENTEE	CROWN WHEEL		1001	
23	00 103.043	4	SK-SCHRAUBE M8X20 - DIN 933	VIS	SCREW		1001	
24	00 165.010	4	HEDTMANN-SICHERHEITSRING 8	RONDELLE GROWER	WASHER, SPRING		1001	
25	00 100.061	1	SK-SCHRAUBE M10X16 DIN 933-8.8	VIS	SCREW		1001	
26	00 167.101	1	SCHEIBE 18X10,2X2,5 ALU	RONDELLE	WASHER		1001	
27	00 107.073	1	VERSCHL-SCHR. M18X1,5 DIN 906	VIS M18X1,5	SCREW M18X1,5		1001	
28	00 162.609	1	SCHEIBE 65X40,2X2	RONDELLE	WASHER		1001	
30	00 166.411	2	SCHEIBE 65X40,2X2	RONDELLE	WASHER		1001	
31	00 166.007	2	SCHEIBE 56X40X0,15	RONDELLE	WASHER		1001	

PNR	TEILE-NR	MENGE	BENENNUNG	DESIGNATION	DESCRIPTION	BEMERK/REMARQUE	AB-NR	BIS-NR
0.01	00	141.65.000.1	1 HYDR.KRATZBODENANTRIEB	HYDR.ENTR.FOND RACL.	HYDR.BOTTOM SCR.DRI.	(1-37)	1001	
1	00	563.01.025.0	1 HALTER	SUPPORT			1001	
2	00	103.63.005.0	1 LASCHE	ECLISSE	PLATE			2577
3	00	141.63.157.1	1 HEBEL	LEVIER	LEVER		1001	
4	00	141.63.168.0	1 SCHALTSTANGE	TIGE DE COMMANDE	HOOK			2616
4.01	00	141.63.168.1	1 SCHALTSTANGE	TIGE DE COMMANDE	HOOK		1001	
5	00	141.63.110.0	2 BUEGEL	POIGNEE	HANDLET		1001	
6	00	141.65.005.0	1 BUEGEL	POIGNEE	HANDLET		1001	
7	00	509.01.016.0	1 BUEGEL	POIGNEE	HANDLET		1001	
8	00	509.01.017.0	1 LASCHE	ECLISSE	PLATE		1001	
9	00	445.031	2 BLOCK-KUGELHAHN BKH	CLAPET A BILLE	BALL VALVE		1001	
10	00	448.1.281	1 GERADE VERSCHRBG.	VISSAGE	THREADED UNION		1001	
11	00	448.117	1 REDUZIERVERSCHRAUBUNG 18-15	RACCORD VISSE	THREADED UNION		1001	
12	00	448.311	1 L-VERSCHRAUBUNG EINSTELLB.15L	RACCORD FILETE EN L	L-CONNECTION		1001	
13	00	448.174	2 L-VERSCHRAUBUNG EINSTELLB.15L	RACCORD FILETE EN L	L-CONNECTIONCREW		1001	
14	00	448.312	1 L-VERSCHRAUBUNG EINSTELLB.18L	RACCORD FILETE EN L	L-CONNECTION		1001	
16	00	448.120	1 UEBERWURFMUTTER AL18	ECROU-CHAPEAU	NUT		1001	
17	00	448.121	1 SCHNEIDRING L18	FILIERE	RING		1001	
18	00	447.1.509.1	1 HYDR. SCHLAUCH NW 12 4600 MM	LIFT DE HYDRAULIQUE	HYDRAULIC LIFT	(47)	1001	
19	00	447.6.802	1 HYDR.SCHLAUCH NW16/4150 DKOL	LIFT DE HYDRAULIQUE	HYDRAULIC LIFT	(48)		2478
19.01	00	447.6.805	1 HYDR.SCHLAUCH NW16 X 4500	TUYAU NW16 X 4500	TUBE NW16 X 4500	(48)	2479	
20	00	518.66.000.0	1 LEITUNGEN F.HYDR. KRATZBOD.	OVERFLOW PIPE	CONDUIT		1001	
21	00	448.093	1 RUECKSCHLAGVENTIL	SOUPAPE DE RETENUE	RETURN VALVE		1001	
22	00	448.402	1 GERADER STUTZEN GS 15	RACCORD VISSE	THREADED UNION		1001	
23	00	162.405	2 SCHEIBE 18X6,5X1,5	RONDELLE	WASHER		1001	
24	00	165.307	2 FEDERRING 5 DIN 128, ZN	RONDELLE GROWER	WASHER, SPRING		1001	
25	00	103.003	2 SK-SCHR. M 5X12 DIN 933-8	VIS HEXAGONAL	SCREW, HEX.HD.		1001	
26	00	162.403	2 SCHEIBE 28X13X3 ZN DIN 1543	RONDELLE	WASHER		1001	
27	00	162.416	4 SCHEIBE 13*2	RONDELLE	WASHER		1001	
28	00	162.404	2 SCHEIBE 20X10,5X1,5 ZN	RONDELLE	WASHER		1001	
29	00	175.239	2 SPLINT 3,2X20 DIN 94	GOUPILLE FENDUE	COTTERPIN		1001	
30	00	118.009	2 SK-SCHR. M8X16	VIS M8X16	SCREW M8X16		1001	
31	00	103.071	1 SK-SCHR. M10X60 DIN 933-8.8	VIS M10X60	SCREW M10X60		1001	
32	00	120.160	1 SK-MUTTER M10 DIN 934-8 ZN	ECROU M10 DIN 934-8	NUT M10 DIN 934-8		1001	
33	00	165.311	1 FEDERRING A10 - DIN 128	RONDELLE	WASHER		1001	
34	00	490.903	1 KUGELKNOPF C40XM10 DIN 319	POIGNEE SPHERIQUE	BALL-HANDLE		1001	
35	00	103.041	1 SK-SCHR. M8X16 DIN 933-8.8	VIS M8X16	SCREW M8X16		1001	
36	00	122.106	1 SI-MUTTER M8 DIN 980-8	ECROU M8 DIN 980	NUT M8 DIN 980		1001	
37	00	447.6.702.1	1 HYDR. SCHLAUCH NW 12 4600 MM	LIFT DE HYDRAULIQUE	HYDRAULIC LIFT		1001	
41	00	518.63.022.0	1 LEITUNG 15 KPL.	CONDUITE	OVERFLOW PIPE	(43,44)	1001	
42	00	518.63.023.0	1 LEITUNG 18 KPL.	CONDUITE	OVERFLOW PIPE	(45,46)	1001	
43	00	448.007	4 UEBERWURFMUTTER AL 15 DIN 3870	ECROU-CHAPEAU	NUT		1001	
44	00	448.008	4 SCHNEIDRING L 15 DIN 3861	FILIERE	RING		1001	
45	00	448.120	4 UEBERWURFMUTTER AL18	ECROU-CHAPEAU	NUT		1001	
46	00	448.121	4 SCHNEIDRING L18	FILIERE	RING		1001	
47	00	415.316	2 O-RING 12X2	JOINT TORIQUE	O-RING		1001	
48	00	415.329	2 O-RING 15X2	JOINT TORIQUE	O-RING		1001	
49	00	448.087	1 STECKER F. SCHNELLVERSCHL. 15	PRISE MÂLE	PLUG		1001	
50	00	448.052	2 STAUBKAPPE	CACHE ROUGE	CAP		1001	
51	00	448.088	1 STECKER F. SCHNELLVERSCHL. 18	PRISE MÂLE	PLUG		1001	

PNR	TEILE-NR	MENGE	BENENNUNG	DESIGNATION	DESCRIPTION	BEMERK/REMARQUE	AB-NR	BIS-NR
0.01	00	517.10.000.2	1 KRATZBODEN	FOND MOUVANT	SCRAPER FLOOR			2519
1	00	103.10.020.0	1 UMLENKBLECH MITTE	TOLE	BAFFLE PLATE			2519
2	00	103.10.025.0	1 UMLENKBLECH MITTE	TOLE	BAFFLE PLATE			2519
3	00	122.10.013.4	1 UMLENKRAD LI ZUS	ROUE DE RENVOI	GUIDE SPROCKET	(41-48 L		2519
4	00	122.10.014.4	1 UMLENKRAD RE ZUS	ROUE DE RENVOI	GUIDE SPROCKET	(41,42,51,44-48 R		2519
5	00	121.10.115.1	2 UMLENKBLECH	TOLE	BAFFLE PLATE			2519
6	00	126.02.064.0	2 KETTENNUSS HINTEN	PIGNON A CHAINE	SPROCKET WHEEL			2519
7	00	126.10.003.1	2 LAGERBOCK	SUPPORT	SUPPORT			2519
8	00	126.10.031.0	2 HOLZKEIL	CLAVETTE	TIMBER WEDGE			2519
9	00	139.10.110.0	10 KRATZBODENLEISTE	BARRE DE FOND RACL.	BAR			2519
10	00	141.02.022.0	1 KRATZBODENWELLE HINTEN	ARBRE	BOTTOM SCRAPER SHAFT			2519
11	00	141.63.132.0	1 DISTANZROHR	TUBE	TUBE			2519
12	00	517.10.004.0	1 BODENBRETT	PLANCHER	BOARD			2519
13	00	517.10.010.0	1 FUEHRUNG LI.LACKIERT	GUIDE	GUIDE	L		2519
14	00	517.10.011.0	1 FUEHRUNG RE.LACKIERT	GUIDE	GUIDE	R		2519
15	00	103.176	2 SK-SCHRAUBE M20X90 DIN 933	VIS M20X90	SCREW M20X90			2519
16	00	103.301	2 SK-SCHR. M10X50 DIN 931 8.8 ZN	VIS M10X50	SCREW M10X50			2519
17	00	103.334	4 SK-SCHRAUBE M12X120 DIN931-8.8	VIS	SCREW			2519
18	00	107.508	20 HAMMERSCHR. A M10X40	VIS TETE RECTANGUL.	HAMMER SCREW			2519
19	00	108.143	6 FLR.SCHR. M 10X25 DIN 603-8.8	VIS M 10X25	SCREW M 10X25			2519
21	00	108.521	6 FLR-SCHRAUBE M10X110 DIN 603	VIS A TETE BOMBEE	FLAT ROUND SCREW			2519
22	00	118.104	16 SCHRAUBE SCT10/35-15-8X65	VIS	SCREW			2519
23	00	120.165	2 SK-MUTTER M20	ECROU M20	NUT M20			2519
25	00	122.107	36 SI-MUTTER M10 DIN 980-8	ECROU M10 DIN 980	NUT M10 DIN 980			2519
26	00	122.108	4 SI-MUTTER M12 DIN 980-8 ZN	ECROU M12 DIN 980-8	NUT M12 DIN 980-8			2519
27	00	150.134	2 PASSFEDER A 12X8X45 DIN 6885	CLAVETTE	KEY			2519
28	00	157.032	2 SICHERUNGSRING 40X1,75 DIN 471	SEGMENT D'ARRET	CIRCLIP			2519
29	00	162.382	6 SCHEIBE 10,5*2,5 DIN 9021	RONDELLE	WASHER			2519
31	00	190.021	2 SCHMIERNIPPEL AR 1/8" DIN71412	RACCORD DE GRAISSEUR	GREASING NIPPLE			2519
32	00	464.005	2 RUNDGLIEDERK.8X31 189 GL.	CHAINE MAILL. RONDS	ROUND LINK CHAIN			2519
33	00	464.090	2 KETTENVERBINDUNGSGLIED 8X31	MAILLON D'ATTACHE	LOCKING LINK			2519
34	00	621.334	20 SCHMIEDETEIL ZWISCHENSTUECK	PART	PART			2519
41	00	121.10.026.0	2 KETTENNUSSGABEL	FOUR. PIGNON CHAIN	FORK			2519
42	00	122.10.016.0	2 KETTENNUSSACHSE	AXE DE PIGNON	AXLE			2519
43	00	122.10.008.2	1 UMLENKBLECH LI.SZ.	TOLE	BAFFLE PLATE	L		2519
44	00	155.026	2 SICHERUNGSRING 30X1,5 DIN471	SEGMENT D'ARRET	CIRCLIP			2519
45	00	191.012	2 SCHMIERN. SFG CM 8X1 DIN 71412	RACCORD DE GRAISSAGE	GREASING NIPPLE			2519
46	00	126.10.024.0	2 KETTENNUSS VORNE	PIGNON A CHAINE	SPROCKET WHEEL			2519
47	00	103.069	4 SK-SCHR. M10X50 DIN 933-8.8	VIS 24X8,5X1,5	SCREW 24X8,5X1,5			2519
48	00	122.107	4 SI-MUTTER M10 DIN 980-8	ECROU M10 DIN 980	NUT M10 DIN 980			2519
51	00	122.10.005.2	1 UMLENKBLECH RE.SZ.	TOLE	BAFFLE PLATE	R		2519

PNR	TEILE-NR	MENGE	BENENNUNG	DESIGNATION	DESCRIPTION	BEMERK/REMARQUE	AB-NR	BIS-NR
0.01	00	455.241/741	1 GELENKW.WWE2380-SD15-1210-K33M	ARBRE A CARDANS	P.T.O. DRIVE SHAFT		1001	2301
2	00	455.741	1 GELENKWELLENHAELFTE INNEN	MOITIE D'ARBRE	DRIVE SHAFT HALF		1001	2301
3	00	455.241	1 GLENKWELLENHAELFTE AUSSEN	MOITIE D'ARBRE	U-JOINT		1001	2301
4	45	85.102	1 SCHUTZHAELFTE AUSSEN	DEMI-PROTECTION	SHIELD		1001	2301
5	45	85.104	1 SCHUTZHAELFTE INNEN	DEMI-PROTECTION	SHIELD		1001	2301
11	45	21.10.810	1 AUFSTECKGABEL KPL.	MACHOIRE A VERROUILL	YOKE, OUTER		1001	2301
12	45	101	1 SCHIEBESTIFT	CHEVILLE COULISSANTE	PIN, QUICK RELEASE		1001	2301
13	00	-	0 --	--	--	*280	1001	2301
21	45	21.06.00	2 KREUZGARNITUR KPL.	CROISILLON	CROSS		1001	2301
22	45	63.27.00	3 KEGEL-SCHMIERNIPPEL	RACCORD DE GRAISSAGE	GREASING NIPPLE		1001	2301
23	45	21.06.70	4 RONDE	RONDELLE	PLATE		1001	2301
24	45	21.91.05	1 DOPPELGABEL	MACHOIRE DOUBLE	DOUBLE YOKE		1001	2301
25	45	63.12.01	1 KEGEL-SCHMIERNIPPEL	RACCORD DE GRAISSAGE	GREASING NIPPLE		1001	2301
26	45	21.11.810	1 RILLENGABEL	MACHOIRE A GORGE	YOKE INNER		1001	2301
27	45	61.05.04	2 SPANNSTIFT	GOUPILLE MECANINDUS	ROLLPIN		1001	2301
28	45	75.11.96	1 PROF. OVAGA	PROFILE	PROFILE OVGA		1001	2301
29	45	75.16.16	1 PROFIL 1 G	PROFILE	SECTION		1001	2301
30	45	21.12.00	1 RILLENGABEL	MACHOIRE A GORGE	YOKE INNER		1001	2301
31	45	21.00.00	1 KREUZGARNITUR KPL.	CROISILLON	CROSS		1001	2301
51	45	85.00.01	1 SCHUTZTRICHTER	CONE PROTECTEUR	GUARD CONE		1001	2301
52	45	60.15.00	8 SCHRAUBE	VIS	SCREW		1001	2301
53	45	82.83.13	1 GLEITRING	BAGUE DE GLISSEMENT	BEARING		1001	2301
54	45	85.14.106	1 SCHUTZTRICHTER	CONE PROTECTEUR	GUARD CONE		1001	2301
55	45	82.83.06	2 GLEITRING	BAGUE DE GLISSEMENT	BEARING		1001	2301
56	45	82.85.00	1 STUETZRING	BAGUE DE SUPPORT	RING		1001	2301
57	45	85.15.05	1 SCHUTZTRICHTER	CONE PROTECTEUR	GUARD CONE		1001	2301
58	45	82.36.03	1 HALTEKETTE	CHAINETTE	CHAIN		1001	2301
59	45	82.36.08	1 HALTEKETTE	CHAINETTE	CHAIN		1001	2301

PNR	TEILE-NR	MENGE	BENENNUNG	DESIGNATION	DESCRIPTION	BEMERK/REMARQUE	AB-NR	BIS-NR
0.01	00	458.187/387	1 GELENKWELLE WWE 654-1100	ARBRE A CARDANS	P.T.O.DRIVE SHAFT		1001	2393
1	44	573040375	1 GABEL MIT BRUECKE	FOURCHETTE	FORK		1001	2393
2	44	412040012	2 KREUZGARNITUR KPL.	CROISILLON	CROSS		1001	2393
3	44	338009000	8 SICHERUNGSRING	SEGMENT D'ARRET	CIRCLIP		1001	2393
4	44	348004000	3 SCHMIERNIPPEL	RACCORD DE GRAISSEUR	GREASING NIPPLE		1001	2393
5	44	511040051	1 MITTELTEIL	PARTIE CENTRALE	CENTRE PART		1001	2393
6	44	215046854	1 AUSSENGABEL	FOURCHE EXTERIEUR	OUTER FORK		1001	2393
7	44	348017000	1 SCHMIERNIPPEL	RACCORD DE GRAISSEUR	GREASING NIPPLE		1001	2393
11	44	341038000	1 SPANNHUELSE AUSSEN	GOUPILLE MECANINDUS	SPLIT TAPER SLEEVE		1001	2393
12	44	225310950	1 PROFILROHR	TUBE PROFILE	PROFILE TUBE		1001	2393
13	44	245100950	1 PROFILROHR	TUBE PROFILE	PROFILE TUBE		1001	2393
14	45	341048000	1 SPANNHUELSE	GOUPILLE MECANINDUS	SPLIT TAPER SLEEVE		1001	2393
21	44	204046852	1 INNENGABEL F. INNENROHR	FOURCHE	INSIDE FORK		1001	2393
22	44	41204	1 KREUZGARNITUR KPL.	CROISILLON	CROSS		1001	2393
23	44	338017000	4 SICHERUNGSRING	SEGMENT D'ARRET	CIRCLIP		1001	2393
28	44	399CEE072	1 AUFKLEBER	ETIQUETTE	DECAL		1001	2393
30	44	6ME341203	1 UEBERLASTKUPPLUNG SN3/4	ACC. SECU. SURCHARGE	OVERLOAD COUPLING		1001	2393
31	44	255040005	1 LAUFRING AUSSEN	BAGUES	RING		1001	2393
32	44	254040009	1 TRICHTER	ENTONNOIR	FUNNEL		1001	2393
33	44	236680897	1 SCHUTZROHR	TUBE DE PROTECTION	TUBULAR GUARD		1001	2393
34	44	236670897	1 SCHUTZROHR	TUBE DE PROTECTION	TUBULAR GUARD		1001	2393
35	44	517040020	1 SCHUTZTRICHTER F. INNEN	CONE PROTECTEUR	GUARD CONE		1001	2393
36	44	255040006	1 LAUFRING INNEN	RING	RING		1001	2393
37	44	252000001	1 HALTEKETTE	CHAINETTE	CHAIN		1001	2393
42	44	255040351	1 LAUFRING	BAGUES	RING		1001	2393
43	44	517048001	1 SCHALE KPL.	ENVELOPPE	BRACKET		1001	2393
49	44	399CEE051	1 CE-ETIKETT	ETIQUETTE	DECAL		1001	2393
51	44	403000001	1 SCHIEBESTIFT KPL.	CHEVILLE COULISSANTE	PIN, QUICK RELEASE		1001	2393
52	44	240080061	1 AUFSTECKNABE	MOYEU A EMBOITER	HUB		1001	2393
71	44	348014000	1 SCHMIERNIPPEL	RACCORD DE GRAISSEUR	GREASING NIPPLE		1001	2393
72	44	422043111	1 GEHAEUSE MIT FLANSCH	BOITIER	HOUSING		1001	2393
73	44	525360301	1 AUFSTECKNABE	MOYEU A EMBOITER	HUB		1001	2393
74	44	421340007	18 SPERRKOERPER M.FEDER	ARRET	PAWL		1001	2393
75	44	240010302	1 KUGEL-RINGVERSCHRAUBUNG	RACCORD VISSE	THREADED UNION		1001	2393
77	44	240000266	1 VERSCHLUSSSCHEIBE	RONDELLE	WASHER		1001	2393
78	44	338005000	1 SICHERUNGSRING	SEGMENT D'ARRET	CIRCLIP		1001	2393
91	44	7E5411000T07	1 GELENKWELLENHAELFTE	MOITIE D'ARBRE	DRIVE SHAFT HALF		1001	2393
92	44	7IR411000V46	1 GELENKWELLENHAELFTE	MOITIE D'ARBRE	DRIVE SHAFT HALF		1001	2393
93	44	7E54110RIT07	1 GELENKWELLENHAELFTE	MOITIE D'ARBRE	DRIVE SHAFT HALF		1001	2393
94	44	7IR4110FFV46	1 GELENKWELLENHAELFTE	MOITIE D'ARBRE	DRIVE SHAFT HALF		1001	2393
95	44	5FE4110E1654	1 SCHUTZHAELFTE	DEMI-PROTECTION	SHIELD		1001	2393
96	44	5FI4110FF	1 SCHUTZHAELFTE	DEMI-PROTECTION	SHIELD		1001	2393
97	44	5F04110E1654	1 UNFALLSCHUTZ	PROTECTEUR	GUARD TOP		1001	2393

PNR	TEILE-NR	MENGE	BENENNUNG	DESIGNATION	DESCRIPTION	BEMERK/REMARQUE	AB-NR	BIS-NR
1	00	494.303	2 AZB „OELSTAND“	ETIQUETTE	DECAL		1001	2453
3	00	494.305	3 AZB „EIN“	ETIQUETTE	DECAL		1001	2453
4	00	494.304	3 AZB „AUS“	ETIQUETTE	DECAL		1001	2453
6	00	494.021	2 DEKORBAND 730	BANDE DECORATIVE	TRANSFER		1001	2453
6.01	00	494.018	1 DEKORBAND RECHTS	BANDE DECOR. DROITE	DECOR.STRIP RIGHT		1001	2453
6.02	00	494.019	1 DEKORBAND LINKS	BANDE DECOR. GAUCHE	DECOR.STRIP LEFT		1001	2453
7	00	494.013	2 AZB „FIRMENZEICHEN“	ETIQUETTE	DECAL		1001	2453
9	00	494.296	3 AZB „BOSS“	ETIQUETTE	DECAL		1001	2453
10	00	494.308	1 AZB „EINLAUFBLECH“	ETIQUETTE	DECAL		1001	2453
11	00	494.302	1 AZB „KURVENFAHRT-ZAPFWELLE“	ETIQUETTE	DECAL		1001	2453
12	00	494.300	2 AZB „L“ WEISS	ETIQUETTE	DECAL		1001	2453
13	00	494.312	1 AZB „BEI LAUFENDEM KRATZBODEN“	ETIQUETTE	DECAL		1001	2453
14	00	494.648	1 ABZIEHBILD „KRATZBODEN“	DECALCOMANIE	TRANSFER		1001	2453
15	00	494.596	1 AZB „REIFENDRUCK“	ETIQUETTE	DECAL		1001	2453
15.01	00	494.743	1 AZB „EINSTELLMASS“	ETIQUETTE	DECAL		1001	2453
15.02	00	494.747	2 AZB „POETTINGER“ 830X76MM WEIS	ETIQUETTE	DECAL		1001	2453
15.03	00	494.748	2 AZB „FIRMENZEICHEN“	ETIQUETTE	DECAL		1001	2453
16	00	517.99.7....	1 BETRIEBSANLEITUNG,ERSATZTEILL.	INST.DE SERV.,LIST	OP.INST. A. SPARE P.		1001	2453
17	00	494.983	1 AZB „UNFALLSCHUTZ GEPRUEFT“	ETIQUETTE	DECAL		1001	2453
18	00	494.339	1 AZB „ACHTUNG KNICKDEICHSEL“	ETIQUETTE	DECAL		1001	2453
19	00	494.321	1 AZB „ACHTUNG STUETZRAD“	ETIQUETTE	DECAL		1001	2453
20	00	494.646	2 AZB „FETTSCHMIERUNG“	ETIQUETTE	DECAL		1001	2453
22	00	494.440	1 AZB „RUECKWAND“	ETIQUETTE	DECAL		1001	2453
23	00	494.444	1 AZB „DUERRFUTTERAUFBAU“	ETIQUETTE	DECAL		1001	2453
24	00	494.443	1 AZB „KNICKDEICHSEL“	ETIQUETTE	DECAL		1001	2453
25	00	494.441	1 AZB „PICK-UP“	ETIQUETTE	DECAL		1001	2453
26	00	495.310	1 AZB „540 U/MIN“ LINKSDREHEND	ETIQUETTE	DECAL		1001	2453
27	00	494.297	2 PVC-KLEBEFOLIE „BOSS“	PLAQUE ADHESIVE	ADHESIVE PLATE		1001	2453
31	00	540.137	1 LACK-POETTINGER-GELB LUFTR.	PEINTURE-JAUNE	CAN OF PAINT YELLOW		1001	2453
32	00	540.139	1 LACK-POETTINGER-ROT-LUFTR.	PEINTURE-ROUGE	CAN OF PAINT-POE.RED		1001	2453
33	00	540.124	1 SPRAYDOSE POETTINGER ROT	PEINT.EN VAPORISAT.	SPRAY CAN-POETT. RED		1001	2453
50	00	455.902	2 UNTERLEGKEIL GROSS	CALE	WHEEL CHOCK		1001	2453
51	00	455.910	2 KEILHALTER GROSS	SUPPORT DE COIN	SHOE PLATE		1001	2453
52	00	103.043	8 SK-SCHRAUBE M8X20 - DIN 933	VIS	SCREW		1001	2453
53	00	162.407	8 SCHEIBE 8,5/18*2	RONDELLE	WASHER		1001	2453
54	00	122.106	8 SI-MUTTER M8 DIN 980-8	ECROU M8 DIN 980	NUT M8 DIN 980		1001	2453
60	00	495.151	1 AZB „CE“	ETIQUETTE	DECAL		1001	2453
61	00	495.164	1 AZB „PICK-UP BEREICH..“	ETIQUETTE	DECAL		1001	2453
62	00	495.165	1 AZB „VOR WARTUNGSARBEIT“	ETIQUETTE	DECAL		1001	2453
63	00	495.154	4 AZB „QUETSCHEN“	ETIQUETTE	DECAL		1001	2453
64	00	495.159	2 AZB „LADEFLAECHE NICHT..“	ETIQUETTE	DECAL		1001	2453
65	00	495.163	2 AZB „BEI LAUF. TRAKTOR..“	ETIQUETTE	DECAL		1001	2453
66	00	495.468	2 AZB „VERSCHLUSS OEFFNEN“	ETIQUETTE	DECAL		1001	2453
67	00	495.158	1 AZB „WARTEN B.ZUM STILLSTAND“	ETIQUETTE	DECAL		1001	2453
68	00	495.177	1 AZB „HECKKLAPPE“	ETIQUETTE	DECAL		1001	2453
70	00	100.03.017.0	16 BEFESTIGUNGSPLATTE 11,5/80-15	PLAQUE DE FIXATION	PLATE		1001	2453
71	00	103.377	8 SK-SCHR. M16X130 DIN931 8.8 ZN	VIS M16X130	SCREW M16X130		1001	2453
72	00	162.409	8 SCHEIBE 34X16,5X3 ZN	RONDELLE	WASHER		1001	2453
73	00	122.110	8 SI-MUTTER M16 DIN 980-8 ZN	ECROU M16 DIN 980	NUT M16 DIN 980		1001	2453

PNR	TEILE-NR	MENGE	BENENNUNG	DESIGNATION	DESCRIPTION	BEMERK/REMARQUE	AB-NR	BIS-NR
0.01	00 517.90.000.0	1	AUSRUESTUNG STANDARD	EQUIPEMENT	EQUIPEMENT	(2-22	2454	
0.02	00 548.91.021.0	1	AUSRUESTUNG FRANKREICH	EQUIPEMENT	EQUIPEMENT	(31	2454	
0.03	00 2091.96.100.0	1	AUSRUESTUNG „MADE IN AUSTRIA“	EQUIPEMENT	EQUIPEMENT	(35	2454	
0.04	00 563.64.020.0	1	SEITLICHE RUECKSTRAHLER	PANNEAU	COVER	(40	2454	
2	00 495.310	1	AZB „540 U/MIN“ LINKSDREHEND	ETIQUETTE	DECAL		2454	
4	00 494.305	2	AZB „EIN“	ETIQUETTE	DECAL		2454	
5	00 494.304	2	AZB „AUS“	ETIQUETTE	DECAL		2454	
7	00 179.123	4	BLINDNIET 3,2X7,8	FAUX RIVET	BLIND RIVET		2454	
9	00 517.90.901.0	1	TYPENSCHILD TYP II -DE-WRK0010	PLAQUE	TYPE PLATE			2478
10	00 563.90.005.0	2	BLENDE	ECRAN	SCREEN		2454	
11	00 118.111	8	BOHR-SCHRAUBE 5,5X16	VIS 5,5X16	SCREW 5,5X16		2454	
12	00 495.084	2	AZB „POETTINGER M.LOGO“900 MM	ETIQUETTE	DECAL		2454	
13	00 495.082	1	AZB „WWW.POETTINGER.AT“ 60 CM	ETIQUETTE	DECAL		2454	
19	00 495.538.0004	2	AZB „BOSS L 22 T“	ETIQUETTE	DECAL		2454	
22	00 495.713	1	AZB „PRODUKTHAFTUNG“	ETIQUETTE	DECAL		2454	
25	00 548.90.902.0	1	TYPENSCHILD TYP II -DE-WRK0010	PLAQUE	TYPE PLATE		2479	
26	00 548.90.904.0	1	TYPENSCHILD TYP II -DE-WRK0010	PLAQUE	TYPE PLATE		2479	2616
27	00 548.90.903.0	1	TYPENSCHILD TYP III-FR-WRK0010	PLAQUE	TYPE PLATE			2616
31	00 495.789	1	AZB „GEWICHTE FRANKREICH“	ETIQUETTE	DECAL		2454	
35	00 494.286.0001	1	AZB „MADE IN AUSTRIA“	ETIQUETTE	DECAL		2454	
40	00 470.960	6	RUECKSTRAHLER 55 ORANGE	CATAPHOTE 55	REFLECTOR 55		2454	

PNR	TEILE-NR	MENGE	BENENNUNG	DESIGNATION	DESCRIPTION	BEMERK/REMARQUE	AB-NR	BIS-NR
0.01	00 141.53.100.0	1	ERWEITERUNGSELEMENT	PROLONGEMENT	EXTENSION	# (1-8	2116	
0.02	00 141.67.000.0	1	ELEKTR.KRATZBODENVORWAHL	ELECTR.PRESELECTION	ELECTR.PRE SELECTION	# (3,6-22	2116	
0.03	00 141.54.100.0	1	VERLAENGERUNGSKABEL	CABLE	CABLE	(7,30-32		2616
1	00 445.182	1	SITZVENTIL	SOUPAPE	VALVE	*410 POS.90	2116	
2	00 448.1.041	1	GERADE EINSCHRAUBVERSCHRAUBUNG	VISSAGE	THREADED UNION		2116	
3	00 103.55.030.0	2	KABEL FUER SITZV.	CABLE	CABLE	# (3,6-8	2116	
4	00 475.364	1	KABELBEZEICHNUNGSRINGE „4“	DESIGNATION BAGUE	DESIGNATION RING		2116	
5	00 475.363	1	KABELBEZEICHNUNGSRINGE „3“	DESIGNATION BAGUE	DESIGNATION RING		2116	
6	00 477.012	2	KABEL 2X1,5	CABLE	CABLE	0,8M	2116	
7	00 475.102	18	ENDHUELSE	DOUILLE	SLEEVE		2116	
8	00 474.030	2	LEITUNGSDOSE M. DICHTUNG	DOUILLE	SOCKET	# (9,10	2116	
9	00 474.031	2	LEITUNGSDOSE	DOUILLE	SOCKET		2116	
10	00 474.032	2	PROFILDICHTUNG	GARNITURE	GASKET		2116	
11	00 445.273	1	ROHRANSCHLUSSGEHAEUSE R 10120	CARTER	HOUSING		2116	
12	00 445.156	1	2/2 SITZVENTIL WSEYR 10120-01	2/2 SOUPAPE	2/2 VALVE		2116	
13	00 448.232	1	GER. EINSCHRAUBSTU. G 1/2" 15	RACCORD VISSE	THREADED UNION		2116	
14	00 447.1.507	1	HYDR.SCHLAUCH NW 12X600	LIFT DE HYDRAULIQUE	HYDRAULIC LIFT	(25		2550
14.01	00 447.1.504	1	HYDR.SCHLAUCH NW12/ 700MM DKO	LIFT DE HYDRAULIQUE	HYDRAULIC LIFT	(25		2551
15	00 448.353	1	WINKELSCHWENKVERSCHR. 15L	RACCORD FILETE COUDE	CONNECTING SCREW		2116	
16	00 448.311	1	L-VERSCHRAUBUNG EINSTELLB.15L	RACCORD FILETE EN L	L-CONNECTION		2116	
17	00 475.365	1	KABELBEZEICHNUNGSRINGE „5“	DESIGNATION BAGUE	DESIGNATION RING		2116	
19	00 448.116	1	EINSCHRAUBVERS.GER.M18X1,5 15	RACCORD VISSE 15	THREADED UNION 15		2116	
20	00 448.007	2	UEBERWURFMUTTER AL 15 DIN 3870	ECROU-CHAPEAU	NUT		2116	
21	00 448.008	2	SCHNEIDRING L 15 DIN 3861	FILIERE	RING		2116	
22	00 447.6.701.1	1	HYDR.SCHLAUCH NW 12 3500MM	CAN.HYDRAULIQUE	HYDR.TUBE	# (25-28	2116	
25	00 415.316	4	O-RING 12X2	JOINT TORIQUE	O-RING		2116	
26	00 447.1.508	1	SCHLAUCH 15, L=3500	TUYAU	HOSE		2116	
27	00 448.087	1	STECKER F. SCHNELLVERSCHL. 15	PRISE MÂLE	PLUG		2116	
28	00 448.052	1	STAUBKAPPE	CACHE ROUGE	CAP		2116	
30	00 477.014	1	OELFLEX-NUMMERNKABEL 7X1,5	CABLE	CABLE		2116	
31	00 474.105	1	STECKER 7-POLIG	PRISE MÂLE	PLUG		2116	
32	00 474.003	1	STECKDOSE 7 POL	PRISE DE COURANT	SOCKET		2116	

NUMMERNVERZEICHNIS

INDICE NUMERICO DEI RICAMI

LISTE NUMERIQUE

NUMERICAL INDEX

0517/02

TN	BT	PN	TN	BT	PN	TN	BT	PN	TN	BT	PN				
00	108.954	0307	24	00	120.159	0100	48	00	122.106	0047	21	00	122.110	0020	13
00	110.102	0047	39	00	120.159	0115	5	00	122.106	0048	45	00	122.110	0045	82
00	110.102	0048	59	00	120.159	0210	27	00	122.106	0060	39	00	122.110	0050	23
00	110.102	0049	56	00	120.159	0450	59	00	122.106	0085	34	00	122.110	0065	7
00	110.102	0065	28	00	120.159	0460	65	00	122.106	0090	18	00	122.110	0085	81
00	112.108	0230	27	00	120.160	0010	11	00	122.106	0100	84	00	122.110	0210	21
00	116.023	0410	12	00	120.160	0030	58	00	122.106	0114	16	00	122.110	0300	73
00	116.023	0410	33	00	120.160	0035	62	00	122.106	0115	16	00	122.112	0140	16
00	116.025	0450	26	00	120.160	0040	12	00	122.106	0115	19	00	122.112	0140	132
00	118.006	0030	28	00	120.160	0045	12	00	122.106	0150	16	00	122.120	0140	108
00	118.006	0460	19	00	120.160	0047	18	00	122.106	0170	41	00	122.220	0015	3
00	118.009	0040	67	00	120.160	0048	30	00	122.106	0185	63	00	122.220	0015	13
00	118.009	0114	37	00	120.160	0085	95	00	122.106	0210	80	00	122.220	0020	8
00	118.009	0114	49	00	120.160	0225	32	00	122.106	0210	113	00	122.220	0140	16
00	118.009	0115	37	00	120.160	0240	10	00	122.106	0225	36	00	122.316	0045	6
00	118.009	0115	49	00	120.160	0460	31	00	122.106	0226	29	00	122.316	0068	5
00	118.009	0170	17	00	120.161	0010	34	00	122.106	0227	29	00	122.316	0076	8
00	118.009	0171	17	00	120.161	0011	34	00	122.106	0230	19	00	122.316	0085	109
00	118.009	0225	30	00	120.161	0030	45	00	122.106	0240	6	00	122.316	0307	10
00	118.009	0290	62	00	120.161	0047	52	00	122.106	0290	44	00	122.317	0011	49
00	118.009	0307	8	00	120.161	0048	40	00	122.106	0300	54	00	122.317	0049	45
00	118.010	0010	22	00	120.161	0049	40	00	122.106	0410	7	00	122.317	0076	7
00	118.010	0011	50	00	120.161	0077	7	00	122.107	0010	9	00	122.317	0170	23
00	118.010	0306	4	00	120.161	0120	14	00	122.107	0011	35	00	122.317	0171	23
00	118.015	0060	35	00	120.161	0185	93	00	122.107	0020	14	00	122.317	0175	2
00	118.017	0085	113	00	120.163	0047	23	00	122.107	0045	90	00	122.317	0177	9
00	118.104	0240	8	00	120.163	0048	33	00	122.107	0047	62	00	122.317	0200	17
00	118.104	0245	22	00	120.163	0049	33	00	122.107	0048	48	00	122.317	0306	5
00	118.111	0040	8	00	120.165	0240	32	00	122.107	0049	47	00	122.317	0307	25
00	118.111	0045	8	00	120.165	0245	23	00	122.107	0060	36	00	122.317	0450	22
00	118.111	0047	36	00	120.306	0077	13	00	122.107	0065	32	00	127.003	0050	5
00	118.111	0065	21	00	120.309	0140	24	00	122.107	0066	16	00	127.003	0055	7
00	118.111	0200	35	00	120.330	0140	21	00	122.107	0067	16	00	127.011	0226	24
00	118.111	0320	11	00	120.359	0145	4	00	122.107	0075	10	00	127.011	0227	24
00	118.111	0410	10	00	120.365	0076	6	00	122.107	0076	9	00	127.018	0010	55
00	118.111	0450	56	00	120.379	0090	22	00	122.107	0077	20	00	127.018	0011	51
00	118.113	0450	56	00	120.396	0170	28	00	122.107	0080	58	00	127.018	0170	33
00	118.201	0035	75	00	120.396	0171	28	00	122.107	0115	42	00	127.018	0171	30
00	118.201	0048	67	00	121.463	0050	2	00	122.107	0140	91	00	128.009	0220	21
00	118.201	0049	57	00	121.512	0055	3	00	122.107	0145	32	00	128.063	0140	22
00	118.201	0066	12	00	122.003	0290	14	00	122.107	0170	20	00	128.107	0077	6
00	118.201	0067	12	00	122.003	0290	47	00	122.107	0171	20	00	129.056	0220	22
00	120.109	0114	5	00	122.005	0155	56	00	122.107	0177	8	00	129.079	0077	5
00	120.109	0180	62	00	122.005	0156	56	00	122.107	0200	20	00	150.122	0100	41
00	120.109	0185	62	00	122.013	0150	6	00	122.107	0210	13	00	150.134	0240	22
00	120.110	0050	32	00	122.056	0080	34	00	122.107	0210	78	00	150.134	0245	27
00	120.110	0080	44	00	122.056	0114	19	00	122.107	0210	91	00	150.139	0240	43
00	120.110	0114	32	00	122.056	0180	63	00	122.107	0240	16	00	150.321	0230	16
00	120.110	0114	42	00	122.057	0050	37	00	122.107	0245	25	00	150.336	0226	21
00	120.110	0180	78	00	122.057	0100	32	00	122.107	0245	48	00	150.336	0227	21
00	120.110	0185	78	00	122.057	0115	32	00	122.107	0410	20	00	150.536	0190	8
00	120.111	0180	27	00	122.057	0145	19	00	122.107	0450	73	00	150.559	0180	41
00	120.113	0180	31	00	122.057	0180	82	00	122.107	0460	52	00	150.687	0085	30
00	120.113	0220	23	00	122.057	0185	82	00	122.108	0010	17	00	150.687	0100	85
00	120.115	0150	9	00	122.057	0240	59	00	122.108	0011	30	00	155.010	0114	57
00	120.155	0290	26	00	122.058	0080	47	00	122.108	0030	17	00	155.014	0070	15
00	120.155	0307	9	00	122.058	0180	15	00	122.108	0040	2	00	155.014	0075	19
00	120.155	0410	55	00	122.058	0185	15	00	122.108	0040	46	00	155.018	0155	6
00	120.156	0290	9	00	122.058	0226	13	00	122.108	0040	62	00	155.018	0156	6
00	120.156	0400	45	00	122.058	0240	26	00	122.108	0045	2	00	155.018	0185	29
00	120.156	0410	22	00	122.059	0155	13	00	122.108	0045	46	00	155.018	0210	64
00	120.156	0410	117	00	122.059	0156	13	00	122.108	0045	62	00	155.022	0210	38
00	120.156	0450	9	00	122.059	0180	81	00	122.108	0047	56	00	155.022	0220	14
00	120.156	0450	31	00	122.059	0185	81	00	122.108	0048	65	00	155.026	0100	42
00	120.156	0450	70	00	122.060	0080	85	00	122.108	0049	61	00	155.026	0114	25
00	120.157	0040	28	00	122.060	0085	85	00	122.108	0060	51	00	155.026	0115	25
00	120.157	0045	28	00	122.061	0080	81	00	122.108	0065	5	00	155.026	0230	15
00	120.157	0270	19	00	122.064	0140	59	00	122.108	0066	3	00	155.026	0240	28
00	120.157	0330	9	00	122.103	0060	41	00	122.108	0067	3	00	155.026	0240	52
00	120.157	0450	46	00	122.104	0040	6	00	122.108	0075	8	00	155.026	0245	44
00	120.159	0010	49	00	122.104	0090	33	00	122.108	0085	47	00	155.029	0210	99
00	120.159	0040	16	00	122.104	0170	35	00	122.108	0155	58	00	155.029	0230	10
00	120.159	0045	16	00	122.104	0290	23	00	122.108	0156	58	00	155.031	0210	66
00	120.159	0047	61	00	122.104	0290	40	00	122.108	0210	29	00	155.032	0080	21
00	120.159	0048	42	00	122.106	0010	23	00	122.108	0227	13	00	155.032	0085	93
00	120.159	0049	42	00	122.106	0030	6	00	122.108	0245	26	00	155.032	0180	47
00	120.159	0100	19	00	122.106	0030	64	00	122.108	0295	8	00	155.032	0185	47

CLICK HERE TO **DOWNLOAD** THE COMPLETE MANUAL

- Thank you very much for reading the preview of the manual.
- You can download the complete manual from: www.heydownloads.com by clicking the link below



- Please note: If there is no response to CLICKING the link, please download this PDF first and then click on it.

CLICK HERE TO **DOWNLOAD** THE COMPLETE MANUAL