

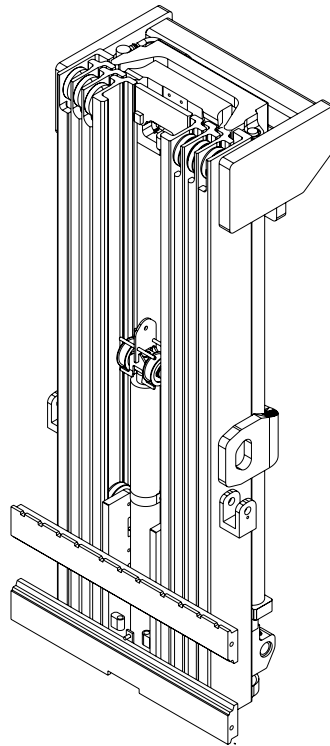

## **45D MQ QUAD MAST PARTS LIST**



**1900 NORTH STREET  
MARYSVILLE, KANSAS 66508  
(785) 562-5381**

CLICK HERE TO **DOWNLOAD** THE COMPLETE MANUAL

- Thank you very much for reading the preview of the manual.
- You can download the complete manual from: [www.heydownloads.com](http://www.heydownloads.com) by clicking the link below



- Please note: If there is no response to CLICKING the link, please download this PDF first and then click on it.

CLICK HERE TO **DOWNLOAD** THE COMPLETE MANUAL

## FREE LIFT CYLINDER (45D-MQ-6359 THRU 45D-MQ-8564)

ITEM	PART NO.	DESCRIPTION	OCL (IN)	QTY.
THIS PAGE DOES NOT APPLY TO SERIAL NUMBERS 45D-MQ-8490, 8512 - 8513, 8521, 8524, 8544 - 8546, 8552, 8555, 8558)				
1	152587	RETAINER		1
2	*	WIPER		1
3	*	O-RING		1
4	*	ROD SEAL		1
5	*	BACK-UP RING		1
6	*	O-RING		1
7	----	SHELL		1
8	----	STAND TUBE		1
9	----	ROD		1
10	----	PULL-IN WIRE (NON SERVICE ITEM - DO NOT REMOVE)		1
11	----	PISTON		1
12	*	PISTON SEAL		1
13	*	WEAR RING		1
14	1422599	FITTING		1
15	**	CHECK VALVE		1
16	*, **	O-RING		1
17	----	PLUG		1
18	1418443	SNAP RING		1
19	133104	SPRING GUIDE		1
20	133109	SPRING		1
21	133083	FUSE PISTON		1
22	133377	FREE LIFT CYLINDER	80	1
	133378	FREE LIFT CYLINDER	86	1
	133379	FREE LIFT CYLINDER	92	1
	133380	FREE LIFT CYLINDER	98	1
	133381	FREE LIFT CYLINDER	104	1
	133209	* CYLINDER SERVICE KIT (INCL ITEMS 2-6, 12-13, 16)		
	133217	** CHECK VALVE KIT (INL ITEMS 15-16)		

NOTE: OCL - OUTER CHANNEL LENGTH

## RIGHT HAND MAIN LIFT CYLINDER (45D-MQ-8565 THRU PRESENT)

ITEM	PART NO.	DESCRIPTION	OCL (IN)	QTY.
1	*	BACK-UP RING		1
2	*	BACK-UP RING		1
3	*	BACK-UP RING		2
4	150881	CHECK VALVE		3
5	----	CUSHION SLEEVE		1
6	1417299	FITTING		1
7	*	NYLON RING		1
8	*	O-RING		1
9	*	O-RING		1
10	*	O-RING		1
11	----	O-RING		1
12	----	PIPE		1
13	----	PISTON		1
14	*	PISTON SEAL		1
15	1422568	FITTING		1
16	152615	RETAINER		1
17	----	RETAINING RING		1
18	----	ROD		1
19	----	ROD END		1
20	*	ROD SEAL		1
21	----	SHELL		1
22	----	SPACER		1
23	----	SPRING		1
24	*	WEAR RING		1
25	*	WIPER		1
26	----	WIRE RING		1
27	152617	RH MAIN LIFT CYLINDER	80	1
	152618	RH MAIN LIFT CYLINDER	86	1
	152619	RH MAIN LIFT CYLINDER	92	1
	152620	RH MAIN LIFT CYLINDER	98	1
	152621	RH MAIN LIFT CYLINDER	104	1

152616            \*SEAL KIT (INCL ITEMS 1-3, 7-10, 14, 20, 24-25)

NOTE: OCL - OUTER CHANNEL LENGTH

## OUTER WELDMENT ASSEMBLY (45D-MQ-001 THRU PRESENT)

ITEM	PART NO.	DESCRIPTION	OCL (IN)	QTY.
1	132643	OUTER UPRIGHT WELDMENT	80	1
	132644	OUTER UPRIGHT WELDMENT	86	1
	132645	OUTER UPRIGHT WELDMENT	92	1
	132646	OUTER UPRIGHT WELDMENT	98	1
	1422624	OUTER UPRIGHT WELDMENT	104	1
2	1422563	CHAIN ANCHOR		2
3	1422591	PIN		2
4	1417344	COTTER PIN		4
5	1417346	COTTER PIN		2
6	1422604	BRACKET		1
7	1418259	FITTING		2
8	133162	FITTING		2
9	1422246	WEAR PLUG SHIM		AR
10	1418252	FITTING		1
11	148258	CAPSCREW, M10 X 1.5 X 50-8.8		2
12	1418247	CAPSCREW, M10 X 1.5 X 25-8.8		2
13	1417274	LOCKWASHER M10		4
14	1422634	FITTING		1
15	1422566	NUT		2
16	1422565	JAM NUT		2
17	1422571	ROLLER		2
18	125774	SHIM		AR
19	126584	WEAR PLUG		2
	133222	COMMON PARTS GROUP		

NOTE: OCL - OUTER CHANNEL LENGTH

NOTE: THE MAST SERIAL NO. MUST BE SUPPLIED.

**INNER WELDMENT ASSEMBLY  
(45D-MQ-884 THRU 45D-MQ-6358)**

ITEM	PART NO.	DESCRIPTION	OCL (IN)	QTY.
1	132661	INNER UPRIGHT WELDMENT	80	1
	132662	INNER UPRIGHT WELDMENT	86	1
	132663	INNER UPRIGHT WELDMENT	92	1
	132664	INNER UPRIGHT WELDMENT	98	1
	1422627	INNER UPRIGHT WELDMENT	104	1
2	1417344	COTTER PIN		4
3	1422562	PIN		2
4	1422546	CHAIN ANCHOR		2
5	1417346	COTTER PIN		2
6	124992	HOSE	80	1
	127576	HOSE	86	1
	132208	HOSE	92	1
	132209	HOSE	98	1
	127574	HOSE	104	1
7	1422199	CAPSCREW, M10 X 1.5 X 20-10.9		1
8	1417274	LOCKWASHER, M10		1
9	1412581	TUBE CLAMP		1
10	1422600	TUBE		1
11	1422576	CAPSCREW, M12 X 35-12.9		2
12	1422601	STANDARD IHR BRACKET		1
	132972	LH IHR BRACKET		1
	1422602	HI-VIS IHR BRACKET		1
13	125841	PAD		1
14	1417962	CAPSCREW, M6 X 12-8.8		2
15	1422574	DOWEL PIN		1
16	23003	LOAD ROLLER SHIM		AR
17	23002DX	LOAD ROLLER		2
18	1417349	NUT		4
19	1417347	JAM NUT		4
20	1422599	FITTING		1
21	151996	BAND		1
22	133342	NUT, M8		2
23	132218	STUD		2
24	1417944	SNAP RING		2
25	23019	SHEAVE		2
26	1418443	SNAP RING		1
27	132266	CROSSHEAD		1
28	1422598	SOCKET HEAD CAPSCREW		2

NOTE: OCL - OUTER CHANNEL LENGTH

## INTERNAL HOSE REEVING - SINGLE FUNCTION STD-VIS (45D-MQ-001 THRU 45D-MQ-883)

ITEM	PART NO.	DESCRIPTION	OCL (IN)	QTY.
1	132667	UPPER GUIDE	80	1
	132668	UPPER GUIDE	86	1
	132669	UPPER GUIDE	92	1
	132670	UPPER GUIDE	98	1
	1422636	UPPER GUIDE	104	1
2	132675	LOWER GUIDE	80	1
	132676	LOWER GUIDE	86	1
	132677	LOWER GUIDE	92	1
	132678	LOWER GUIDE	98	1
	1422637	LOWER GUIDE	104	1
3	132212	HOSE	80	1
	132213	HOSE	86	1
	132214	HOSE	92	1
	132215	HOSE	98	1
	127573	HOSE	104	1
4	133340	CAPSCREW, M10 X 1.5 X 100 CL8.8		1
5	132655	SHAFT		2
6	132246	TIRE		2
7	1418248	LOCKWASHER, M10		10
8	1418243	NUT, M10		4
9	132654	SHAFT		4
10	132653	TIRE		4
11	132642	SHAFT		1
12	133169	SHEAVE		2
13	1419468	SHIM		1
14	51983	SNAP RING		1
15	133258	LOCKWASHER, M12		1
16	1422259	CAPSCREW, M12 X 1.75 X 55 CL8.8		1
17	132651	HOSE GUARD		2
18	1418247	CAPSCREW, M10 X 1.5 X 25 CL8.8		4
19	132221	SPACER		1
20	132222	INSERT		9
21	132666	BAR		5
22	3GM610ER	CAPSCREW, M6 X 1.0 X 20 CL8.8		14
23	132665	BAR		1
24	132259	INSERT		1
25	*	BRACKET		1
	152798	COMMON PARTS KIT (INCL ITEMS 4-25)		

\* WHEN REPLACING ORIGINAL BRACKET, ORDER BRACKET P/N 132305 (QTY 1), FITTING P/N'S 1418006, 1417986, 132574 (QTY 1 EACH), AND FREE LIFT HOSES PER MAST OCL FROM PAGE 1-41.

NOTE: OCL - OUTER CHANNEL LENGTH

## INTERNAL HOSE REEVING - SINGLE FUNCTION HI-VIS LH (45D-MQ-884 THRU PRESENT)

ITEM	PART NO.	DESCRIPTION	OCL (IN)	QTY.
1	132908	HOSE CLAMP		4
2	1422642	HOSE CLAMP		6
3	132909	HOSE CLAMP BAR		2
4	132910	HOSE CLAMP BAR		3
5	1418006	BULKHEAD UNION 90		1
6	1418247	CAPSCREW, M10 X 25		6
7	1419450	CAPSCREW, M12 X 65		1
8	3GM610ER	CAPSCREW, M6 X 20		1
9	1422643	CAPSCREW, M6 X 25		10
10	133344	CAPSCREW, M8 X 20		1
11	1417986	BULKHEAD UNION		1
12	123574	FITTING		1
13	1422648	HOSE GUARD		2
14	132305	CARRIAGE BRACKET		1
15	133013	IHR SPACER		3
16	132459	INSTALLATION INSTRUCTIONS		1
17	1417274	M10 LOCKWASHER		7
18	133258	M12 LOCKWASHER		1
19	1418019	M6 LOCKWASHER		1
20	132216	M8 LOCKWASHER		1
21	132975	LOWER GUIDE	80	1
	132976	LOWER GUIDE	86	1
	132977	LOWER GUIDE	92	1
	132978	LOWER GUIDE	98	1
	132979	LOWER GUIDE	104	1
22	1419457	#6 CAP PLUG		2
23	1418243	M10 NUT		1
24	1419452	M12 NUT		1
25	132403	HOSE RETAINER PLATE		1
26	132913	HOSE RETAINER PLATE		1
27	132401	SHEAVE		3
28	132267	SHEAVE		2
29	133335	SNAP RING		3
30	1419448	STUBSHAFT		2
31	133005	UPPER BRACKET		1
32	132985	UPPER GUIDE	80	1
	132986	UPPER GUIDE	86	1
	132987	UPPER GUIDE	92	1
	132988	UPPER GUIDE	98	1
	132989	UPPER GUIDE	104	1
33	132974	UPPER GUIDE BRACKET		1
34	1419471	WASHER		3
35	1422576	CAPSCREW, M12 X 35		2
36	125841	BUMPER PAD		1
37	1417962	CAPSCREW		2

## INTERNAL HOSE REEVING - DOUBLE FUNCTION HI-VIS (45D-MQ-884 THRU PRESENT)

ITEM	PART NO.	DESCRIPTION	OCL (IN)	QTY.
1	132908	HOSE CLAMP		2
2	1422642	HOSE CLAMP		8
3	132910	HOSE CLAMP BAR		4
4	132909	HOSE CLAMP BAR		1
5	132973	UPPER IHR BRACKET		1
6	1422649	CARRIAGE BRACKET		1
7	1422602	LOWER INNER BRACKET		1
8	1418006	BULKHEAD UNION 90		4
9	1417962	CAPSCREW		2
10	1418247	CAPSCREW, M10 X 25		6
11	1422576	CAPSCREW, M12 X 35		2
12	1422270	CAPSCREW, M12 X 100		1
13	3GM610ER	CAPSCREW, M6 X 20		1
14	1422643	CAPSCREW, M6 X 25		10
15	133344	CAPSCREW, M8 X 20		1
16	1422574	DOWEL PIN		1
17	132379	GUIDE BAR		1
18	132439	LOWER GUIDE	80	1
	132440	LOWER GUIDE	86	1
	132441	LOWER GUIDE	92	1
	132442	LOWER GUIDE	98	1
	132443	LOWER GUIDE	104	1
19	132444	UPPER GUIDE	80	1
	132445	UPPER GUIDE	86	1
	132446	UPPER GUIDE	92	1
	132447	UPPER GUIDE	98	1
	132448	UPPER GUIDE	104	1
20	1422648	HOSE GUARD		2
21	133013	IHR SPACER		5
22	133018	LOWER INTERMEDIATE INSERT		1
23	132459	INSTALLATION INSTRUCTIONS		1
24	1417274	M10 LOCKWASHER		7
25	133258	M12 LOCKWASHER		1
26	1418019	M6 LOCKWASHER		1
27	132216	M8 LOCKWASHER		1
28	1419457	#6 CAP PLUG		4
29	1418243	M10 NUT		1
30	1419452	M12 NUT		1
31	125841	BUMPER PAD		1
32	132404	HOSE RETAINER PLATE		1
33	132913	HOSE RETAINER PLATE		1
34	132401	SHEAVE		5
35	1422646	SHEAVE		2
36	133335	SNAP RING		5
37	1422268	STUBSHAFT		2

**LANDOLL MAST P/N TABLE - 45D QUAD**

LANDOLL PART #	DESCRIPTION	FREELIFT "A"	OAL "B"	MFH "C"	NO. OF ROLLERS		CARRIAGE			INTERNAL HOSE REEVING		
					4	6	31"	35.5"	37"	SINGLE	DOUBLE	COLD STORAGE
100699	MAST, 45D, 83/240, 635, SR CS	58	83	240		X			X		X	
100736	MAST, 45D, 83/240, 635, DR CS	58	83	240		X			X			X
100772	MAST, 45D, 83/240, 631 SR CS	58	83	240		X	X					X
100773	MAST, 45D, 83/240, 631 DR CS	58	83	240		X	X				X	
133629	MAST, 45D, 87/250, 631, SR CS	62	87	250		X	X				X	
116485	MAST, 45D, 87/250, 631, DR CS	62	87	250		X	X				X	
100737	MAST, 45D, 89/258, 635, SR CS	64	89	258		X			X			X
100738	MAST, 45D, 89/258, 635, DR CS	64	89	258		X			X			X
100774	MAST, 45D, 89/258, 631, SR CS	64	89	258		X	X				X	
100775	MAST, 45D, 89/258, 631, DR CS	64	89	258		X	X				X	
127513	MAST, 45D, 91/264, 631, SR CS	66	91	264		X	X				X	
100739	MAST, 45D, 95/276, 635, SR CS	70	95	276		X			X			X
100740	MAST, 45D, 95/276, 635, DR CS	70	95	276		X			X			X
100776	MAST, 45D, 95/276, 631, SR CS	70	95	276		X	X				X	
100777	MAST, 45D, 95/276, 631, DR CS	70	95	276		X	X				X	
100741	MAST, 45D, 101/294, 635, SR CS	76	101	294		X			X			X
100742	MAST, 45D, 101/294, 635, DR CS	76	101	294		X			X			X
100778	MAST, 45D, 101/294, 631, SR CS	76	101	294		X	X				X	
100779	MAST, 45D, 101/294, 631, DR CS	76	101	294		X	X				X	
100743	MAST, 45D, 107/312, 635, SR CS	82	107	312		X			X			X
100744	MAST, 45D, 107/312, 635, DR CS	82	107	312		X			X			X
100780	MAST, 45D, 107/312, 631, SR CS	82	107	312		X	X				X	
100781	MAST, 45D, 107/312, 631, DR CS	82	107	312		X	X				X	

CLICK HERE TO **DOWNLOAD** THE COMPLETE MANUAL

- Thank you very much for reading the preview of the manual.
- You can download the complete manual from: [www.heydownloads.com](http://www.heydownloads.com) by clicking the link below



- Please note: If there is no response to CLICKING the link, please download this PDF first and then click on it.

CLICK HERE TO **DOWNLOAD** THE COMPLETE MANUAL