

Instructions for Parts Books

The heading at the top of the page will be the same for the picture of the parts as it is for the page with the part numbers.

Definition of column headings on part number pages:

REF.No → The number referring to the part on the picture page of the parts book.

Part No. → The number assigned to this part at the time of printing the parts book.

Description → Description of part.

Q'ty → Quantity of part used on that page.

S.No. → Serial number range of the equipment that this part will fit.

>= Your serial number should be greater than or equal to the number shown.

<= Your serial number should be lesser than or equal to the serial number shown.

I/C → Interchangeability of part shown.

↔ The part shown will work for the older and later serial number.

The part shown is not interchangeable with the other serial number.

← new for old

→ old for new

Remarks → Notes about this particular part. Sometimes this may say except [FR] or [CA]

Note about Country Codes:

The parts books we use in the United States of America may also contain information about a part that would be different in another country. It is important that you are aware of the country codes in some instances.

Symbol	Country
A	United States of America
CA	Canada
FR	France
GR	Greece
PO	Portugal
AU	Australia

If the remarks column says for example EXCEPT [FR] this part works in all countries except France. That means it will work here in the USA.

CLICK HERE TO **DOWNLOAD** THE COMPLETE MANUAL

- Thank you very much for reading the preview of the manual.
- You can download the complete manual from: www.heydownloads.com by clicking the link below



- Please note: If there is no response to CLICKING the link, please download this PDF first and then click on it.

CLICK HERE TO **DOWNLOAD** THE COMPLETE MANUAL

CYLINDER HEAD

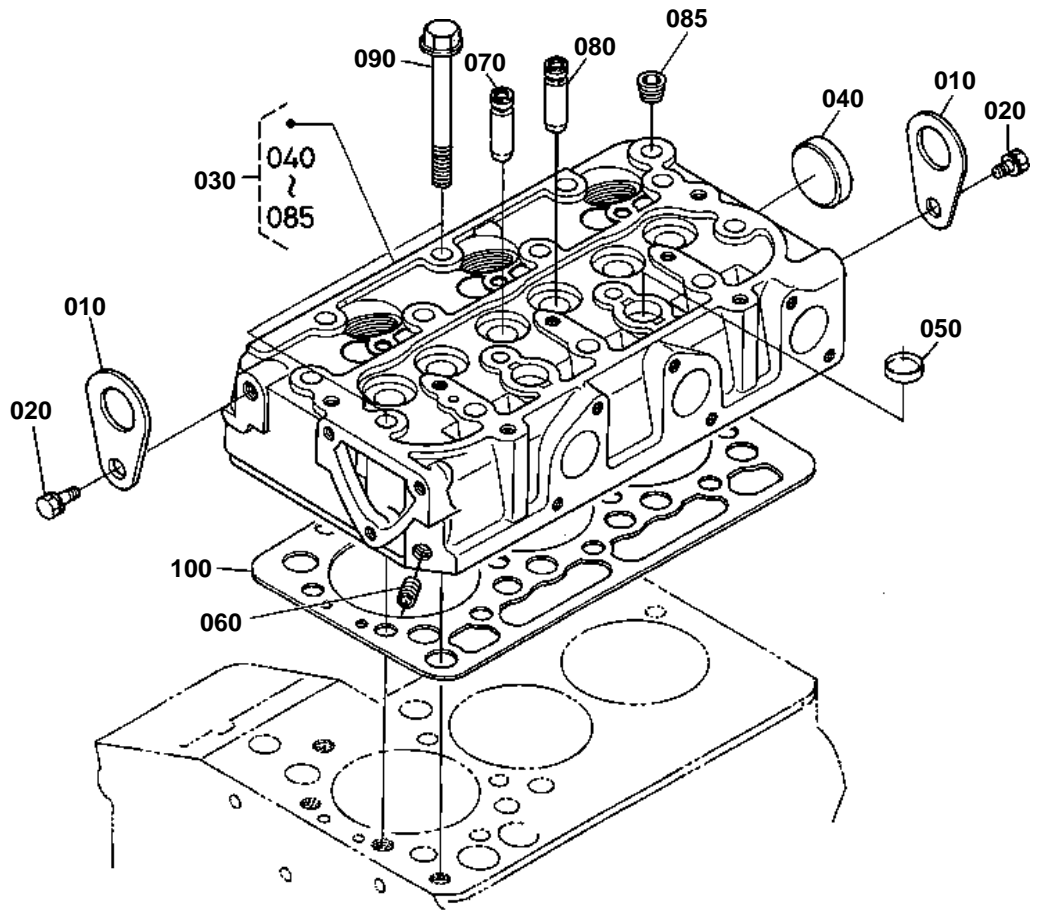

1G005-011-10



OIL FILTER

↔ Interchangeable; ≠ not interchangeable; ← new for old; → old for new

REF.No	Part No.	Description	Q'ty	S.No.	I/C	REMARKS	Weight (kgf)	Weight (lb)
010	15853-32430	CARTRIDGE OIL FILTER	1				0.195	0.429

PISTON AND CRANKSHAFT

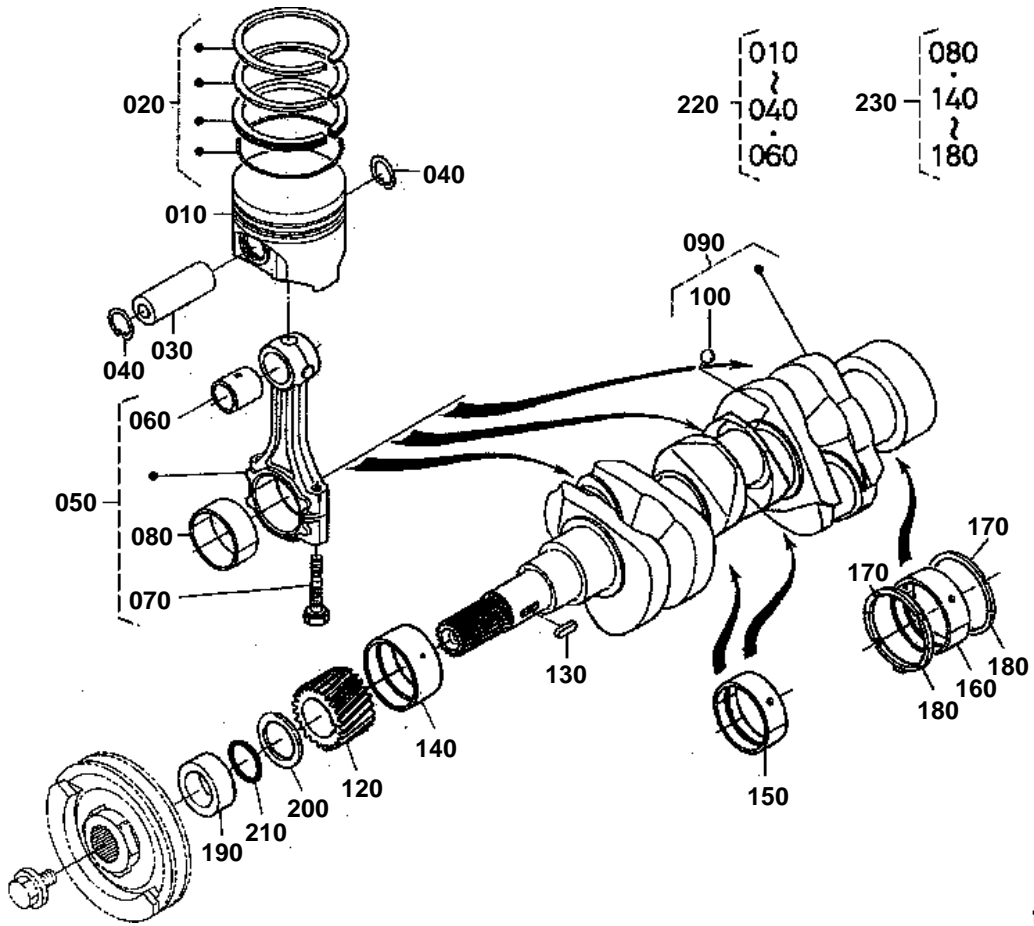

1G005-005-10

GOVERNOR

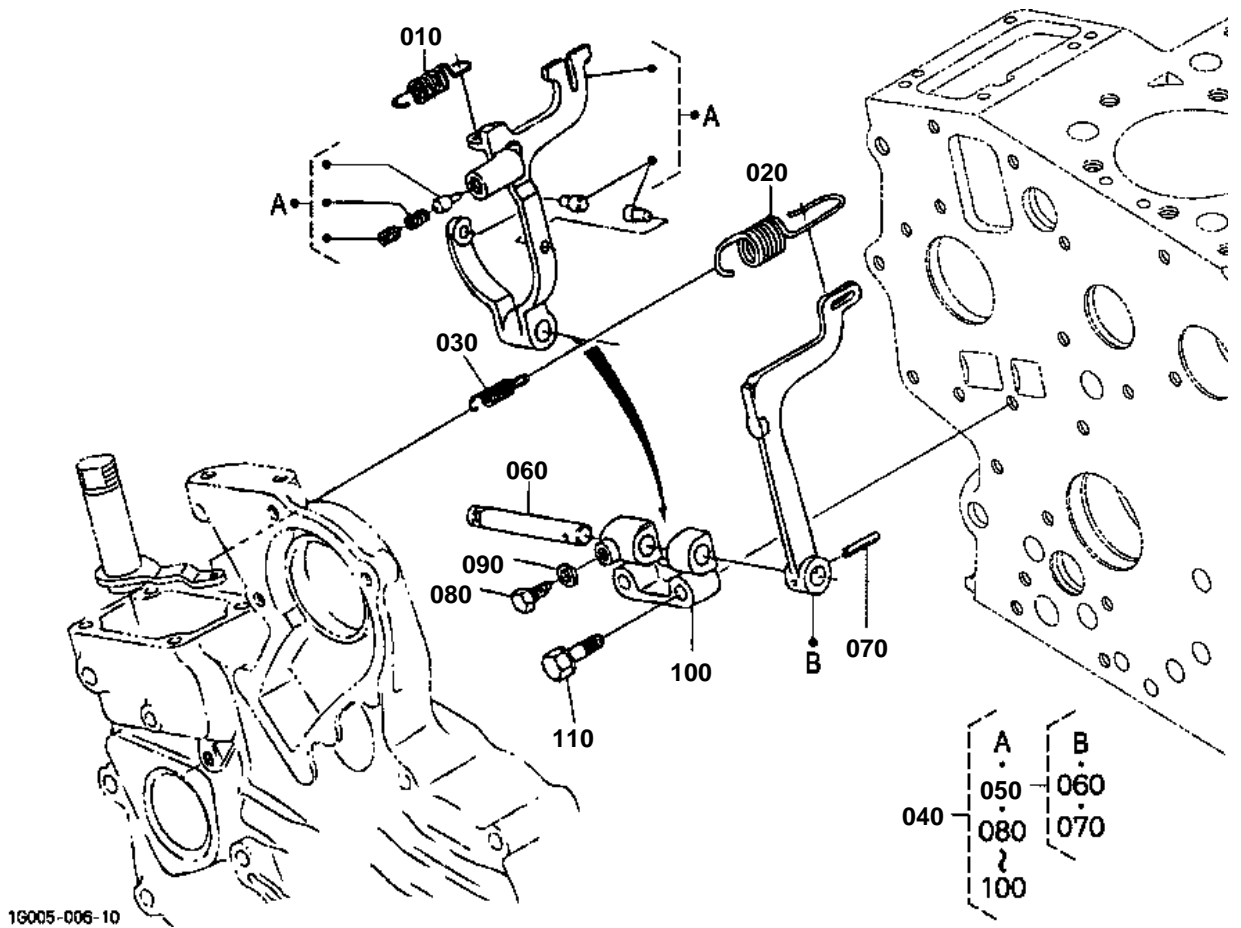

19005-006-10

FUEL PUMP(MECHANICAL)

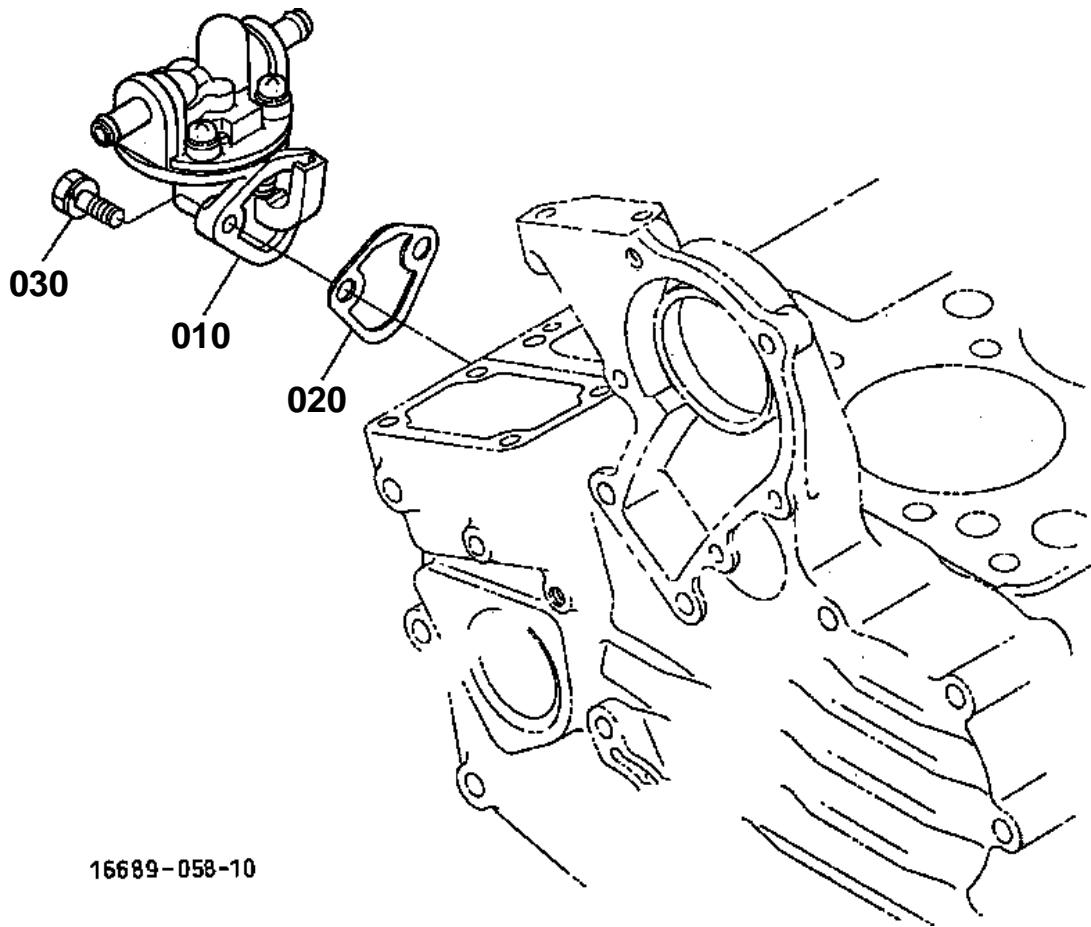

16689-058-10

INLET MANIFOLD

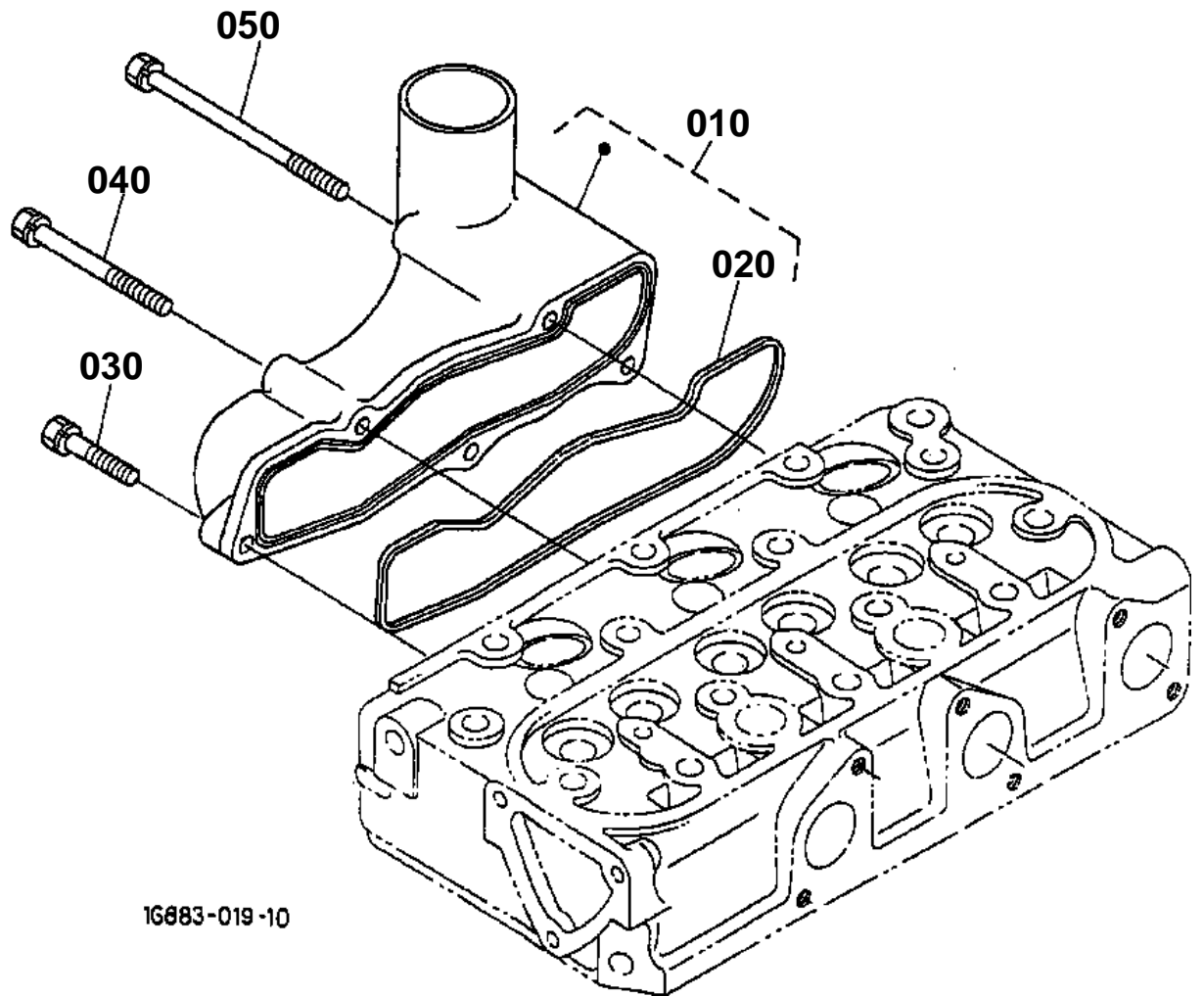

1G683-019-10

UPPER GASKET KIT [OPTION]

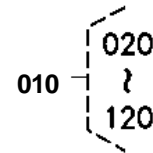
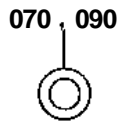
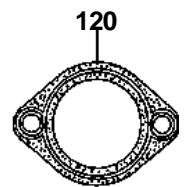
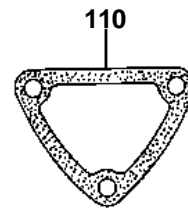
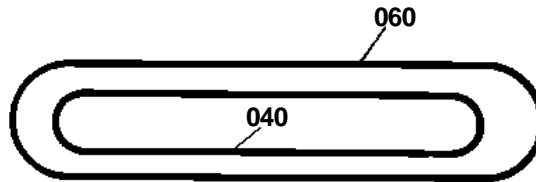
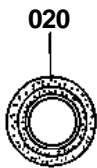
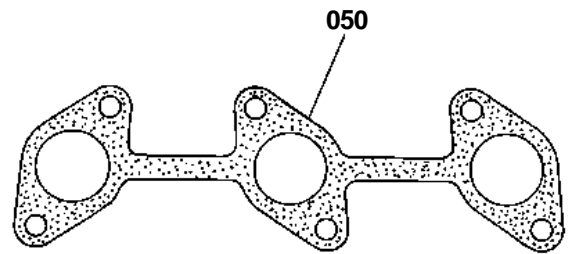
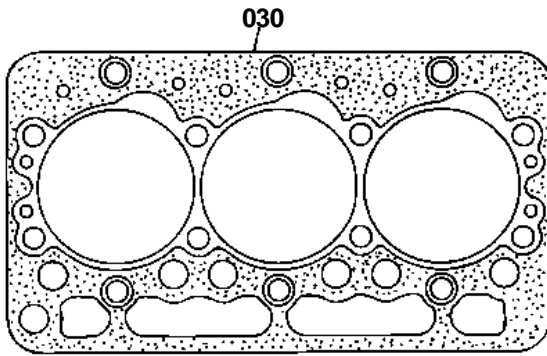

1G008-011-10

FUEL PIPE

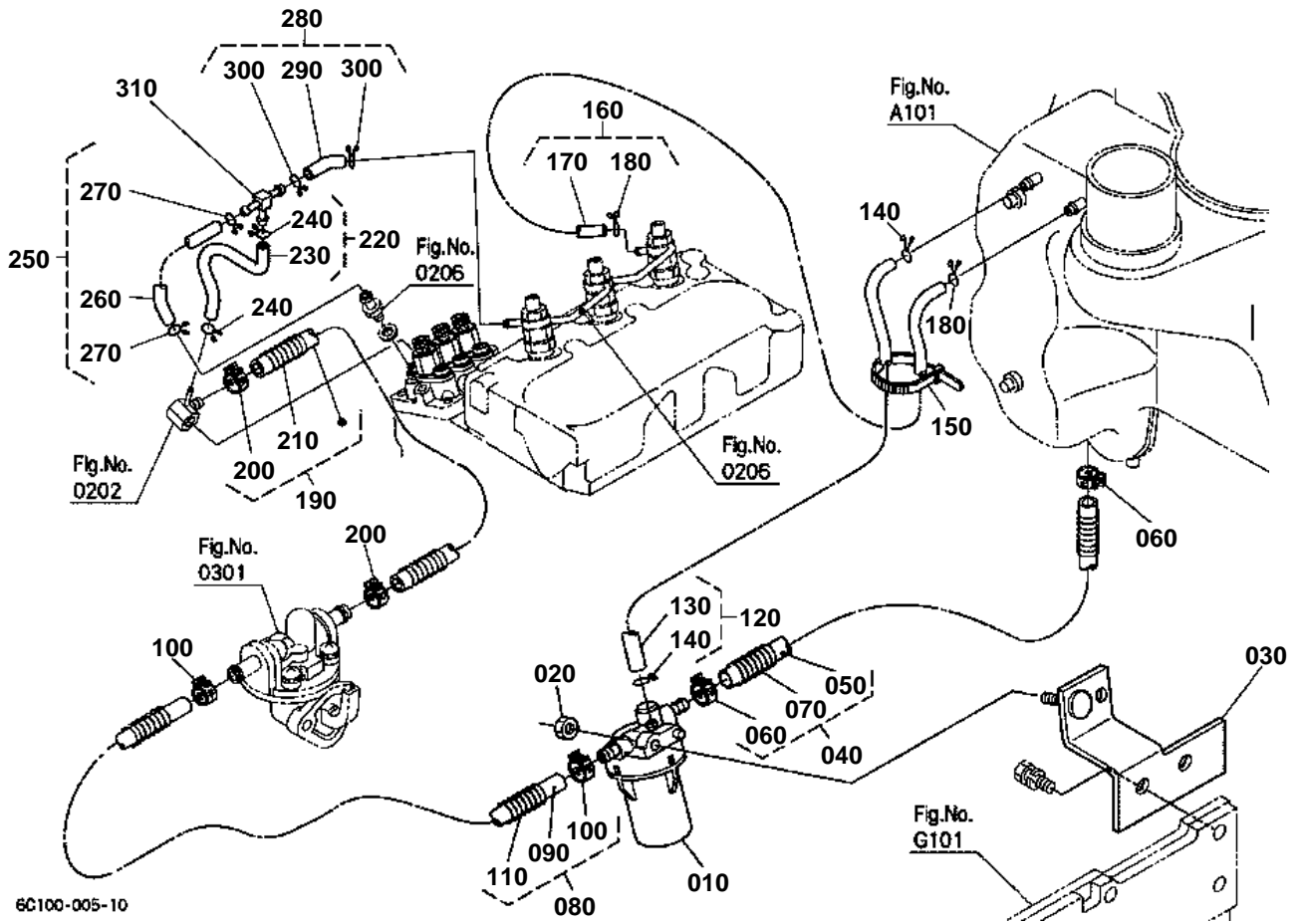

6C100-005-10

RADIATOR [AU] [NZ]

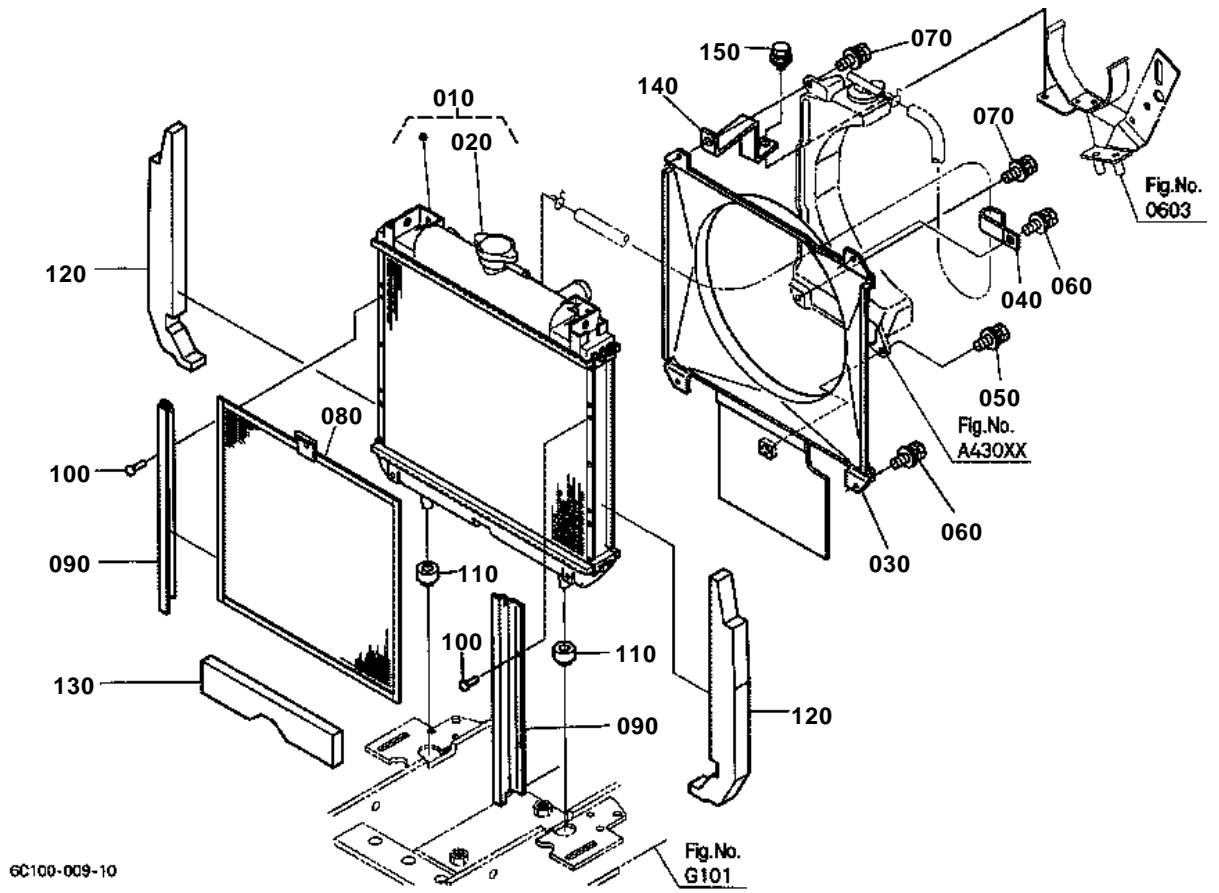

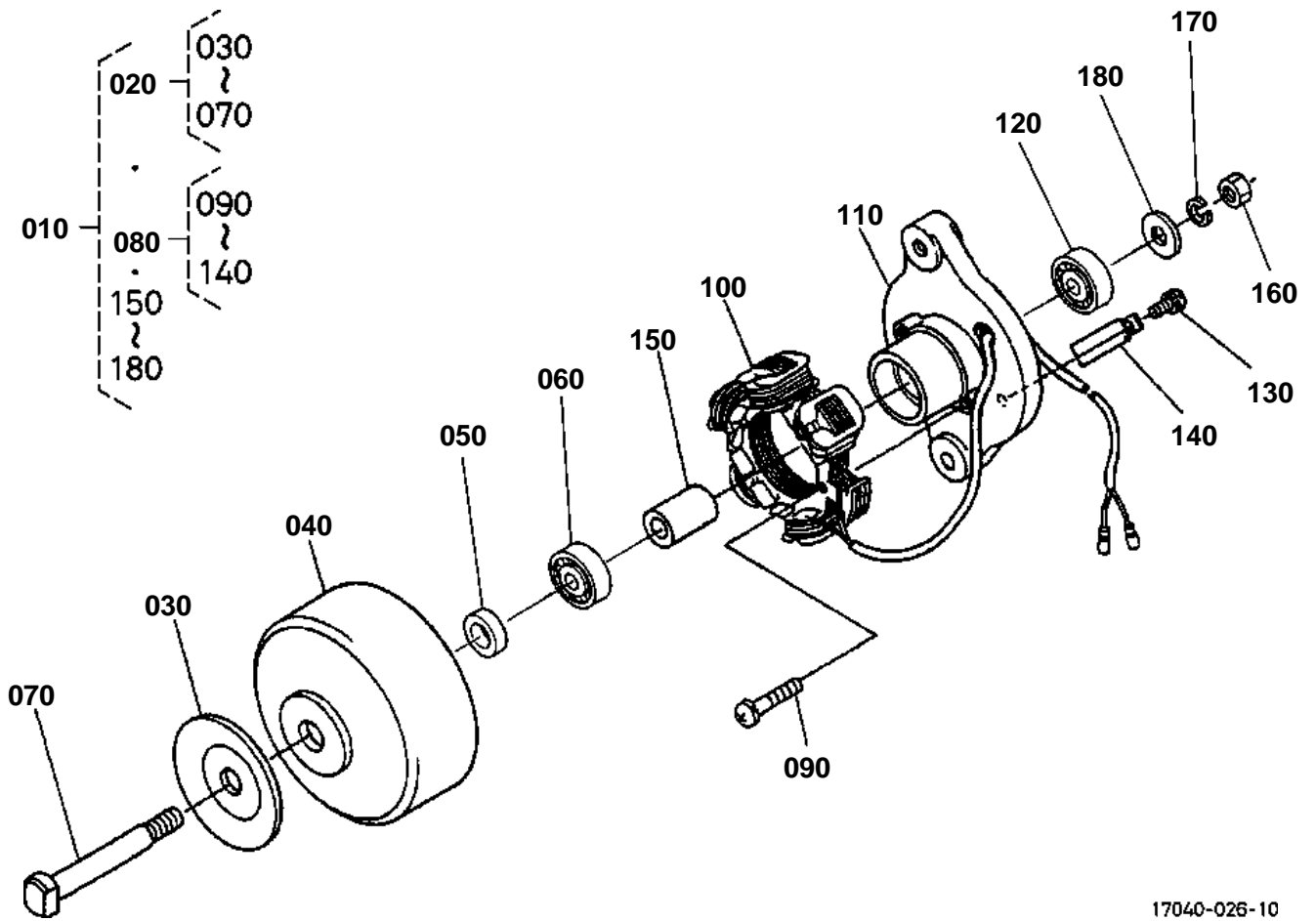

17040-026-10

PANEL BOARD

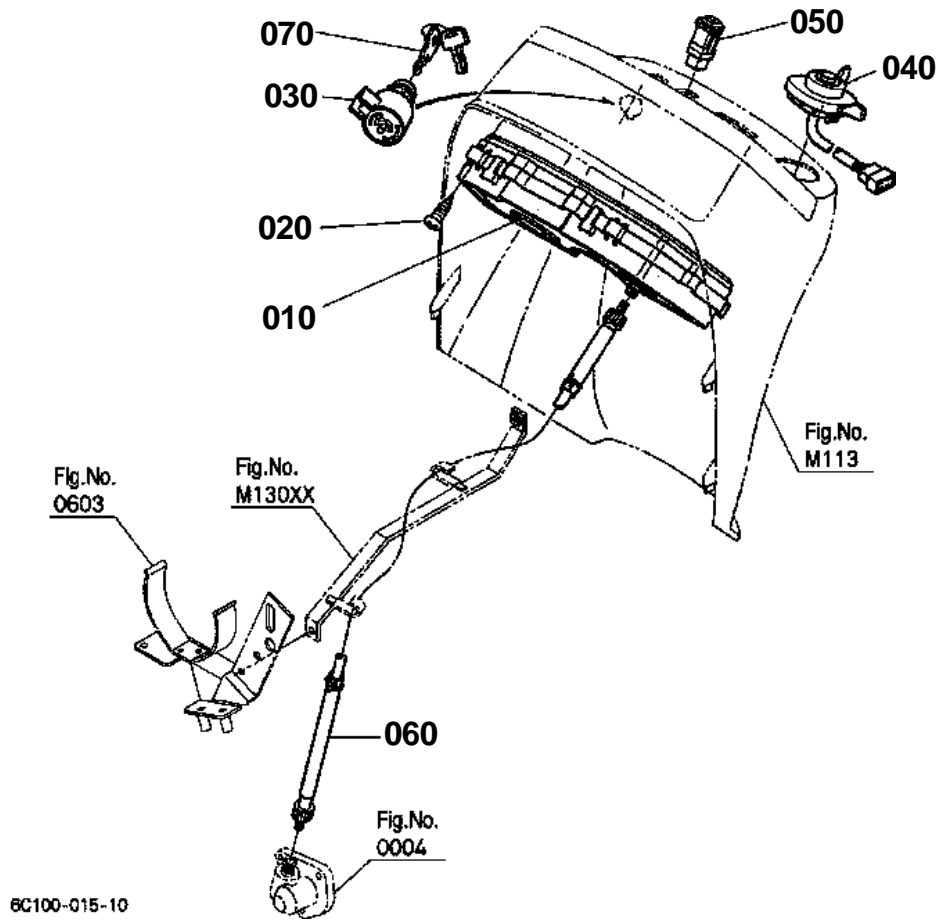

WINKER LAMP

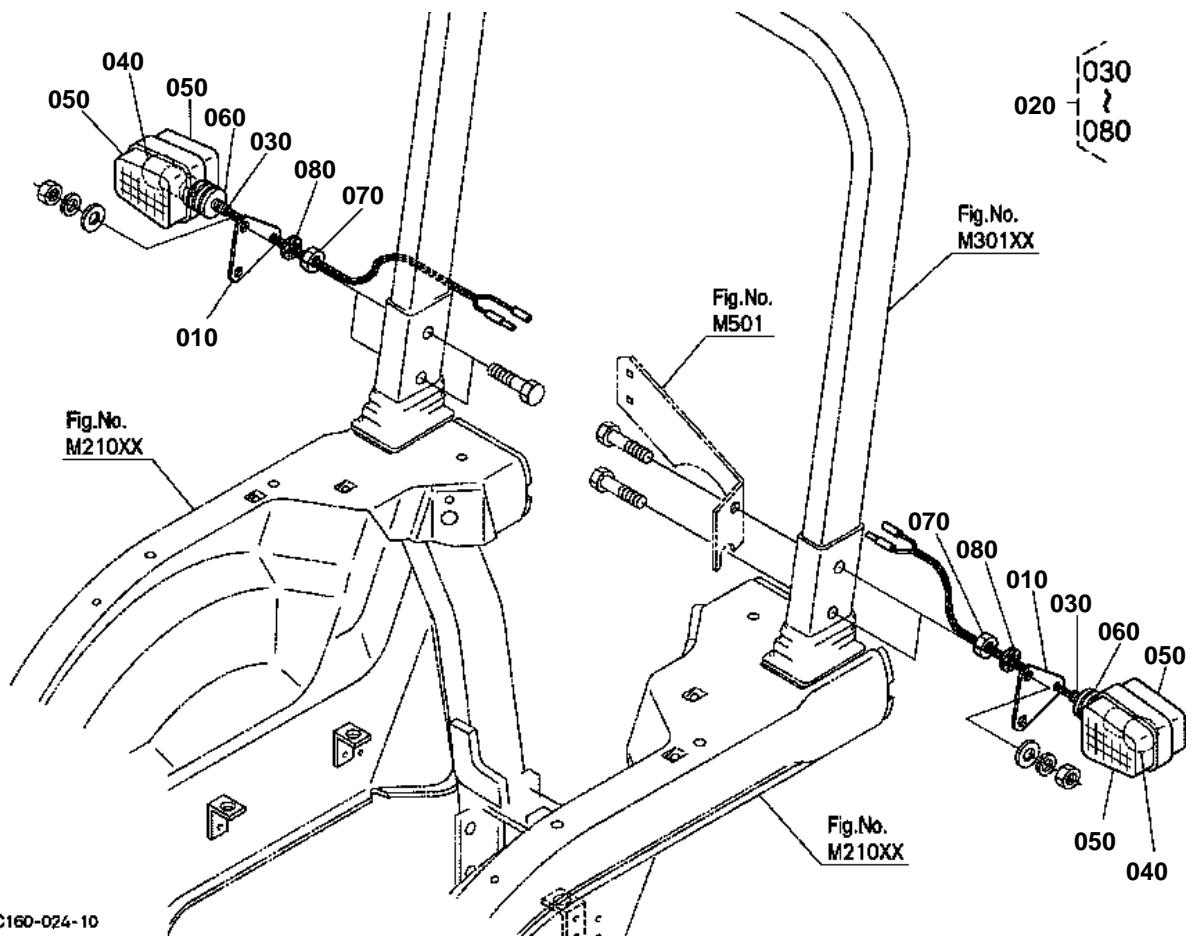

CLUTCH HOUSING

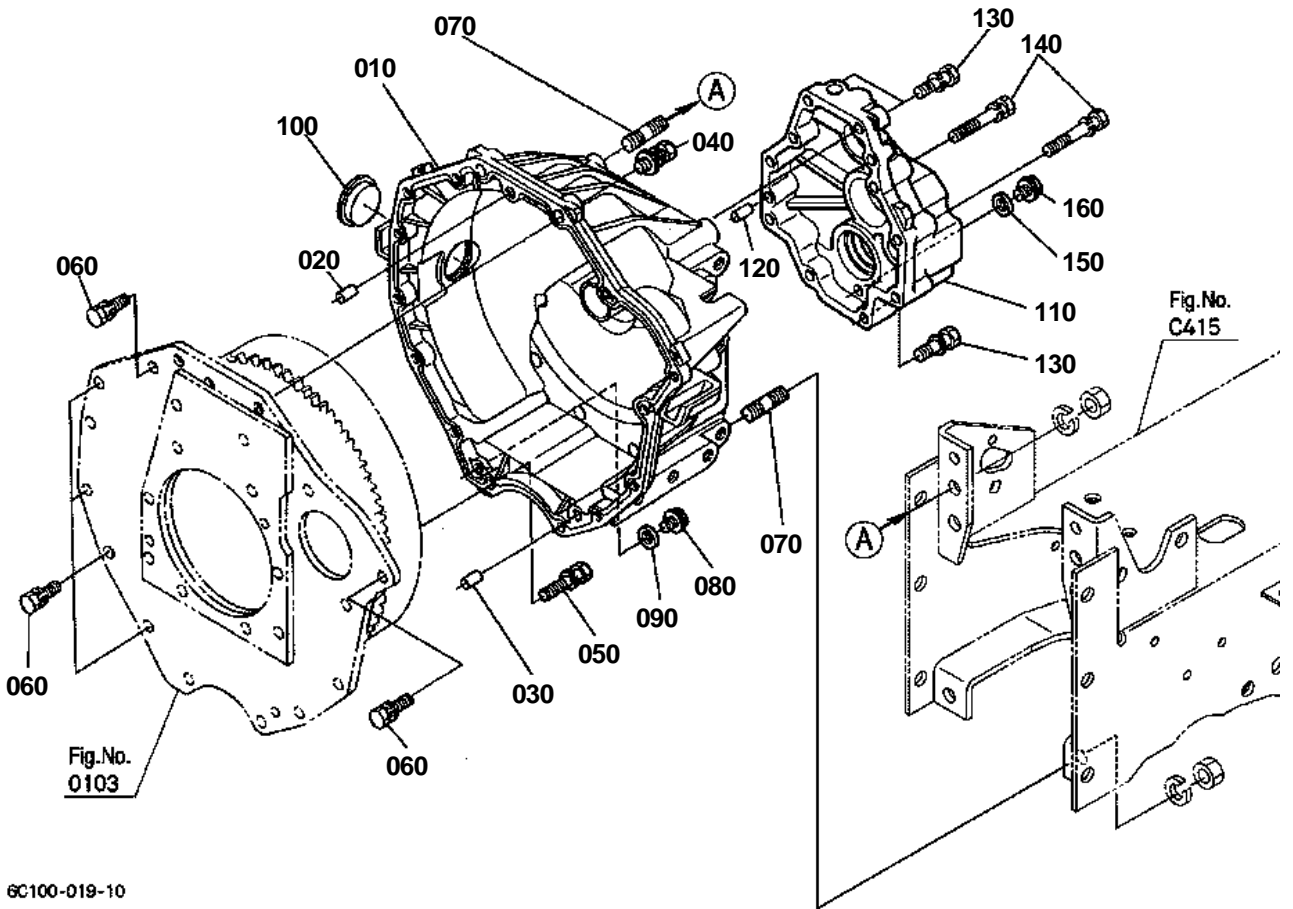

REAR AXLE CASE

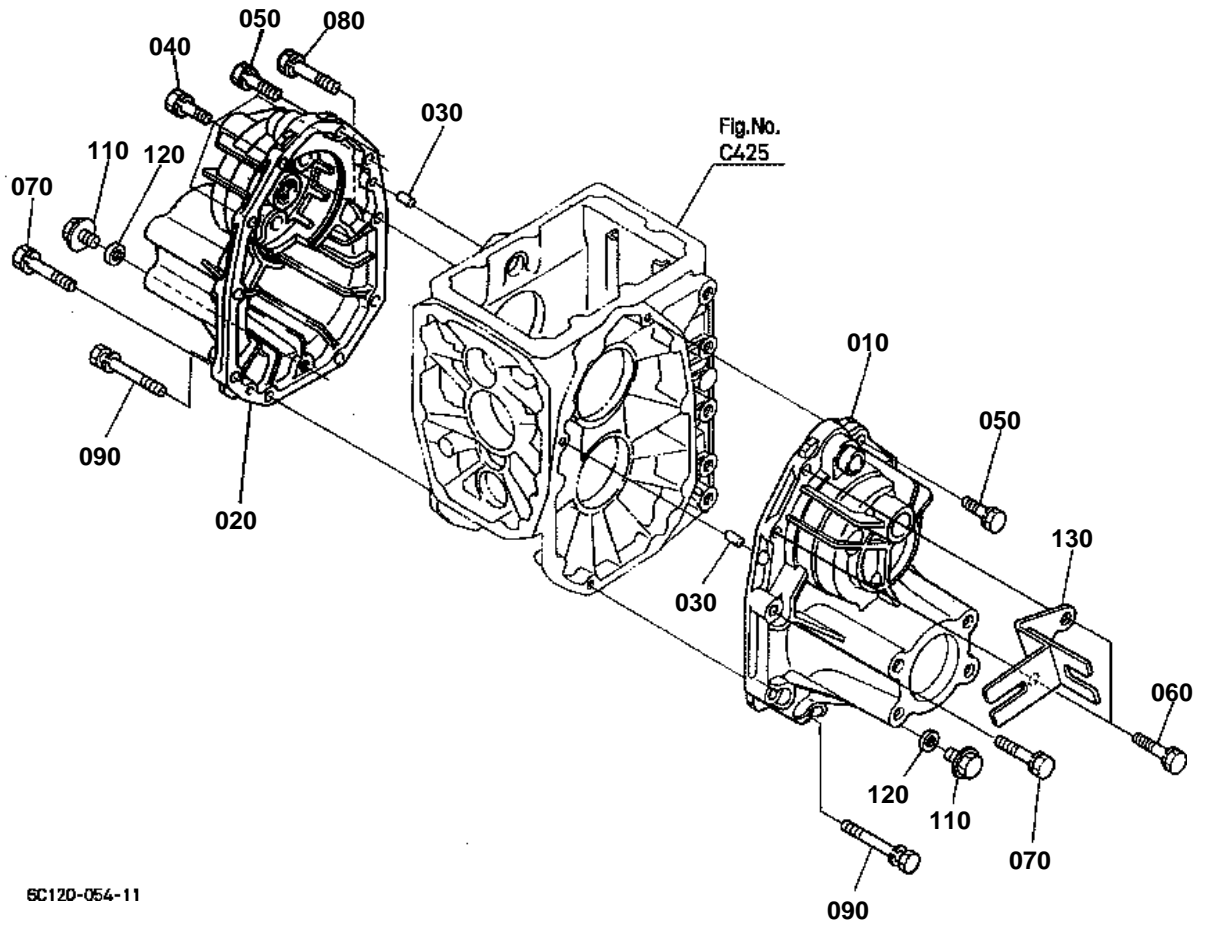

8C12D-054-11

REAR DIFFERENTIAL

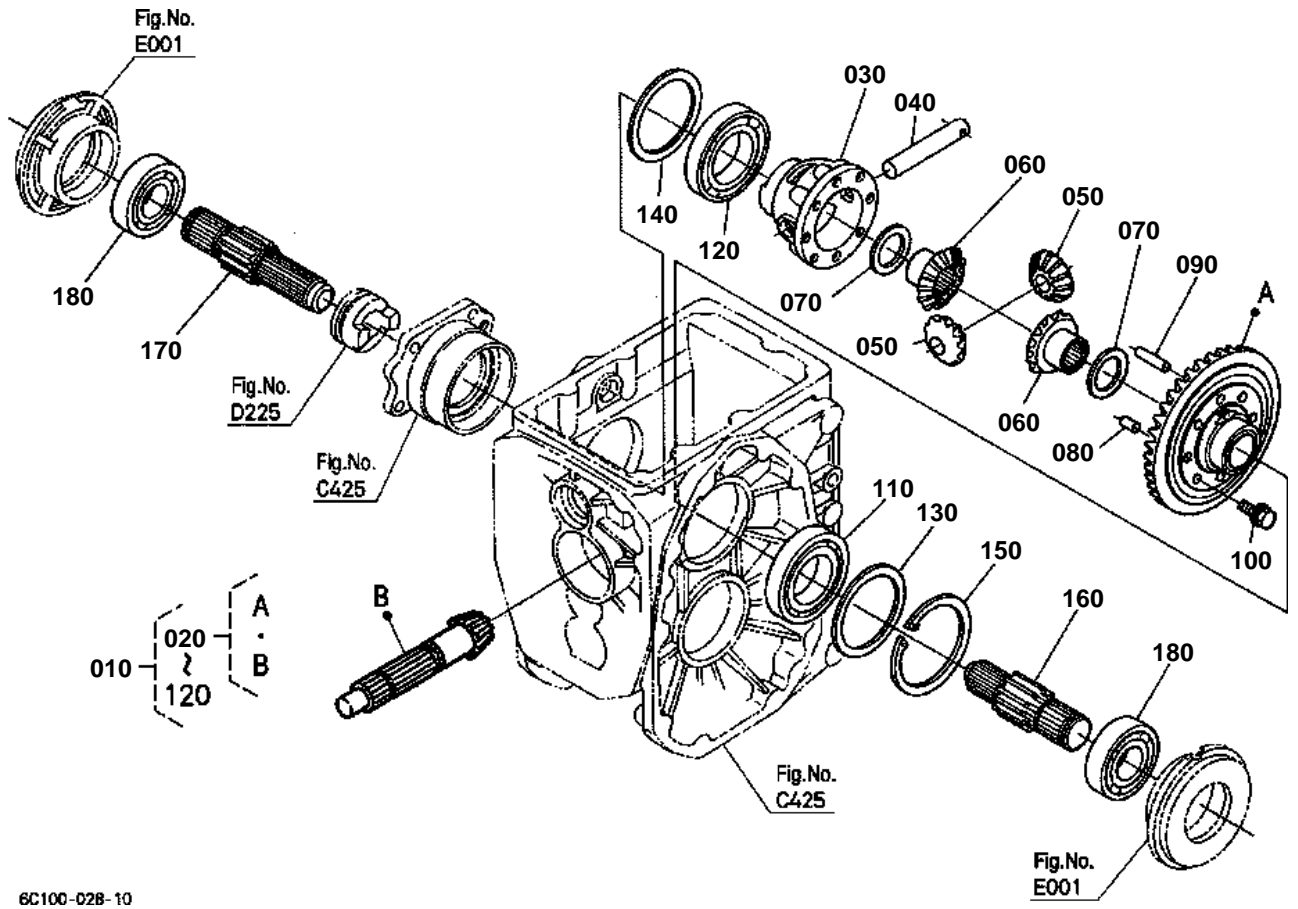

6C100-02B-10

CLICK HERE TO **DOWNLOAD** THE COMPLETE MANUAL

- Thank you very much for reading the preview of the manual.
- You can download the complete manual from: www.heydownloads.com by clicking the link below



- Please note: If there is no response to CLICKING the link, please download this PDF first and then click on it.

CLICK HERE TO **DOWNLOAD** THE COMPLETE MANUAL

MAIN GEAR SHIFT FORK

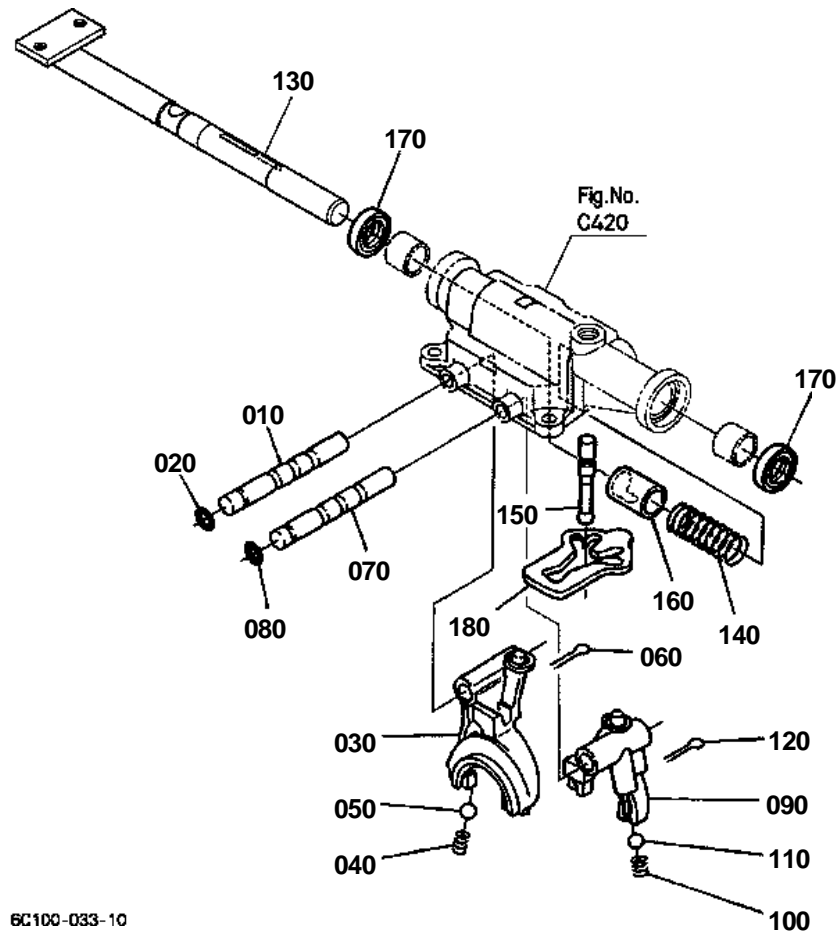

BRAKE

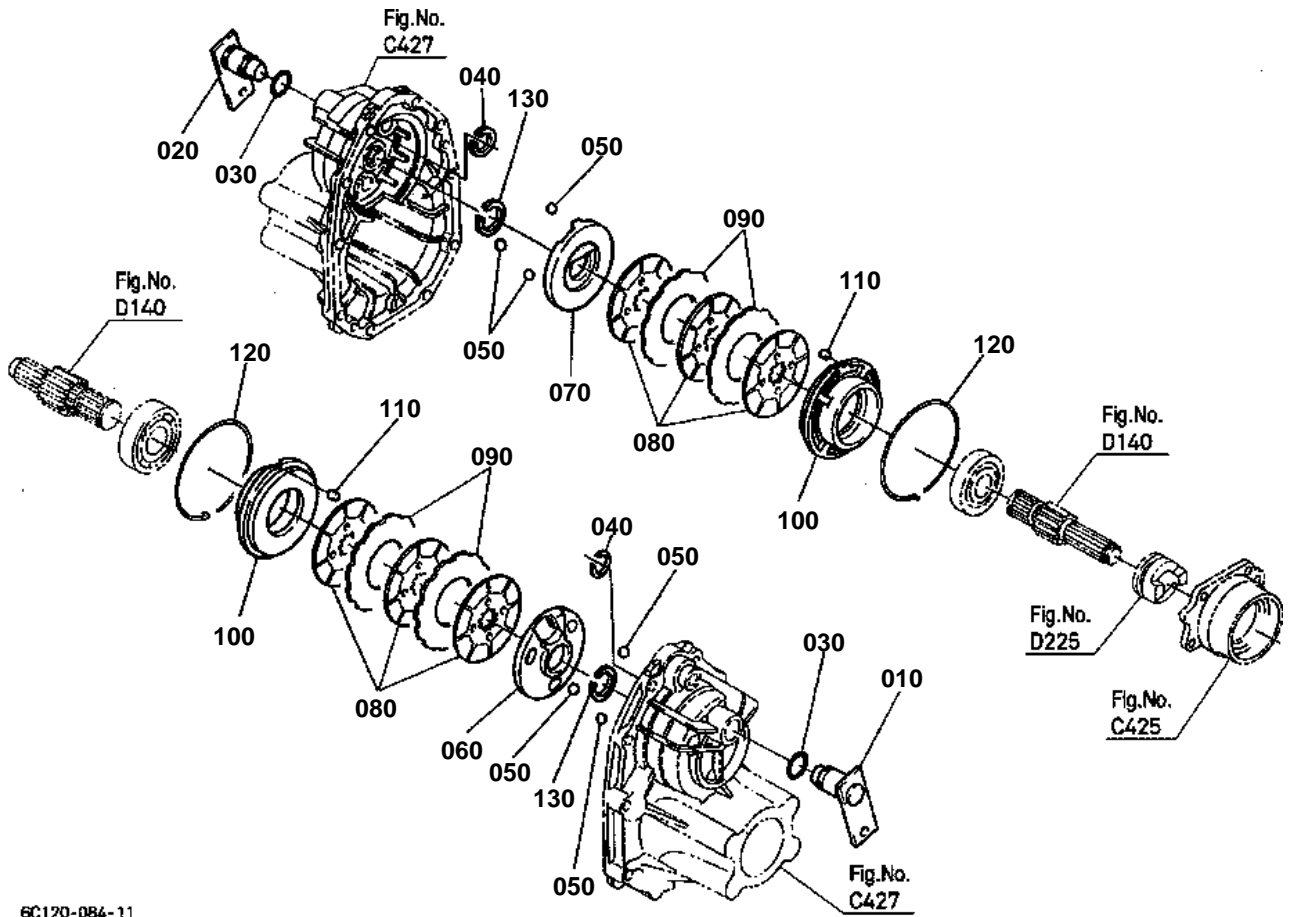

6C120-084-11

RANGE GEAR SHIFT LEVER

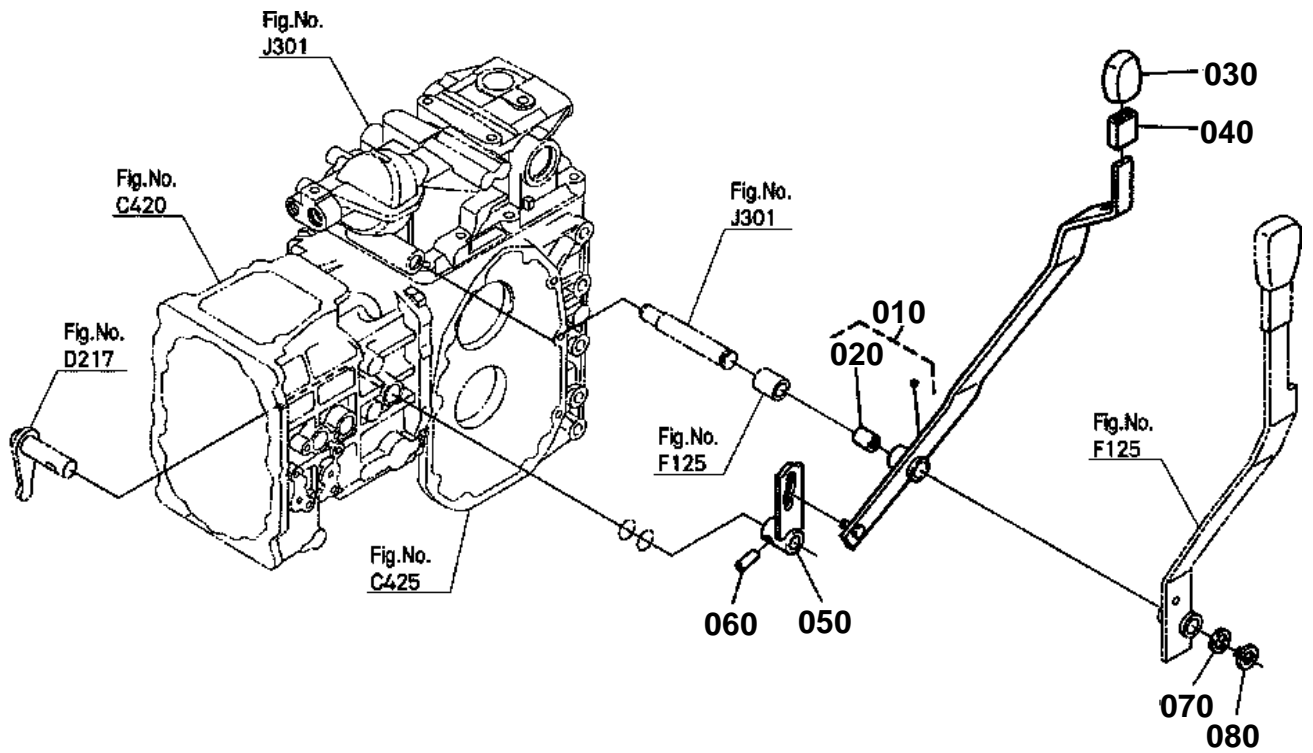

6C100-041-10

DIFFERENTIAL LOCK PEDAL

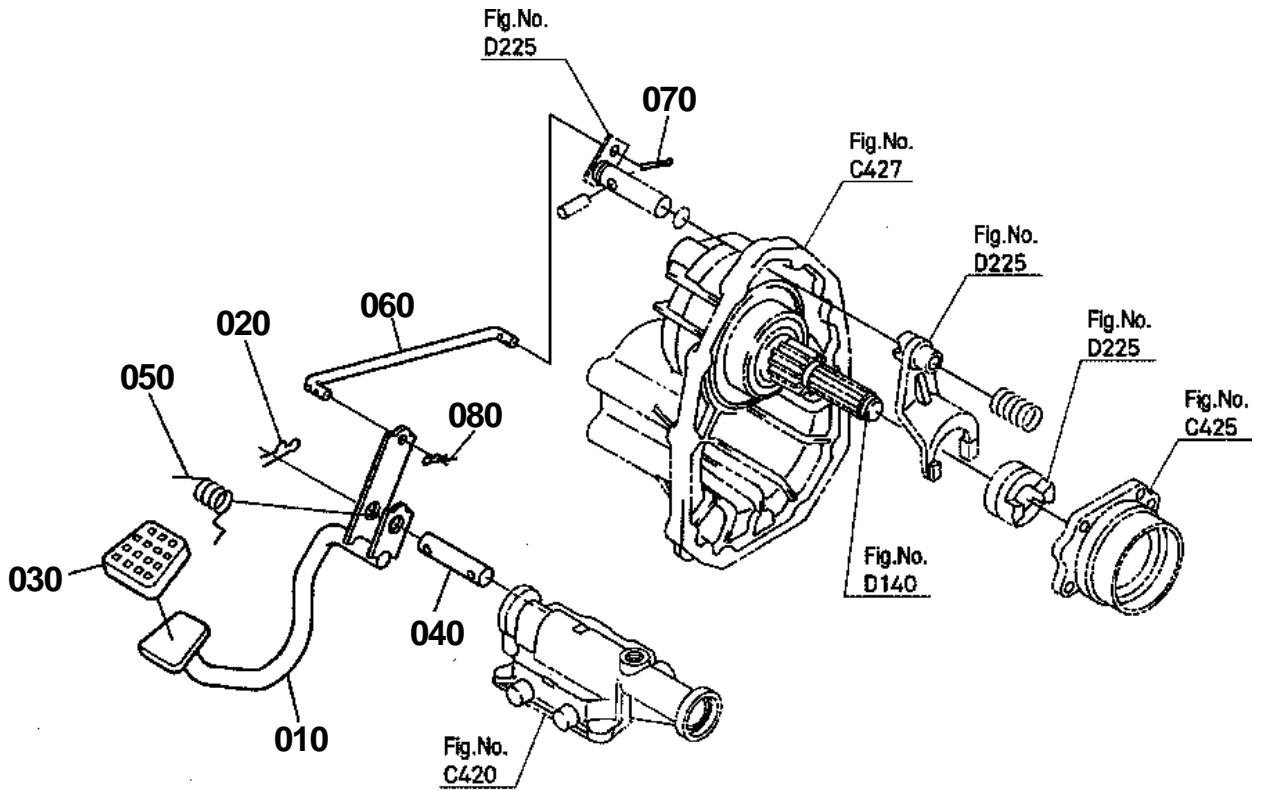

6C100-046-10

BEVEL GEAR CASE

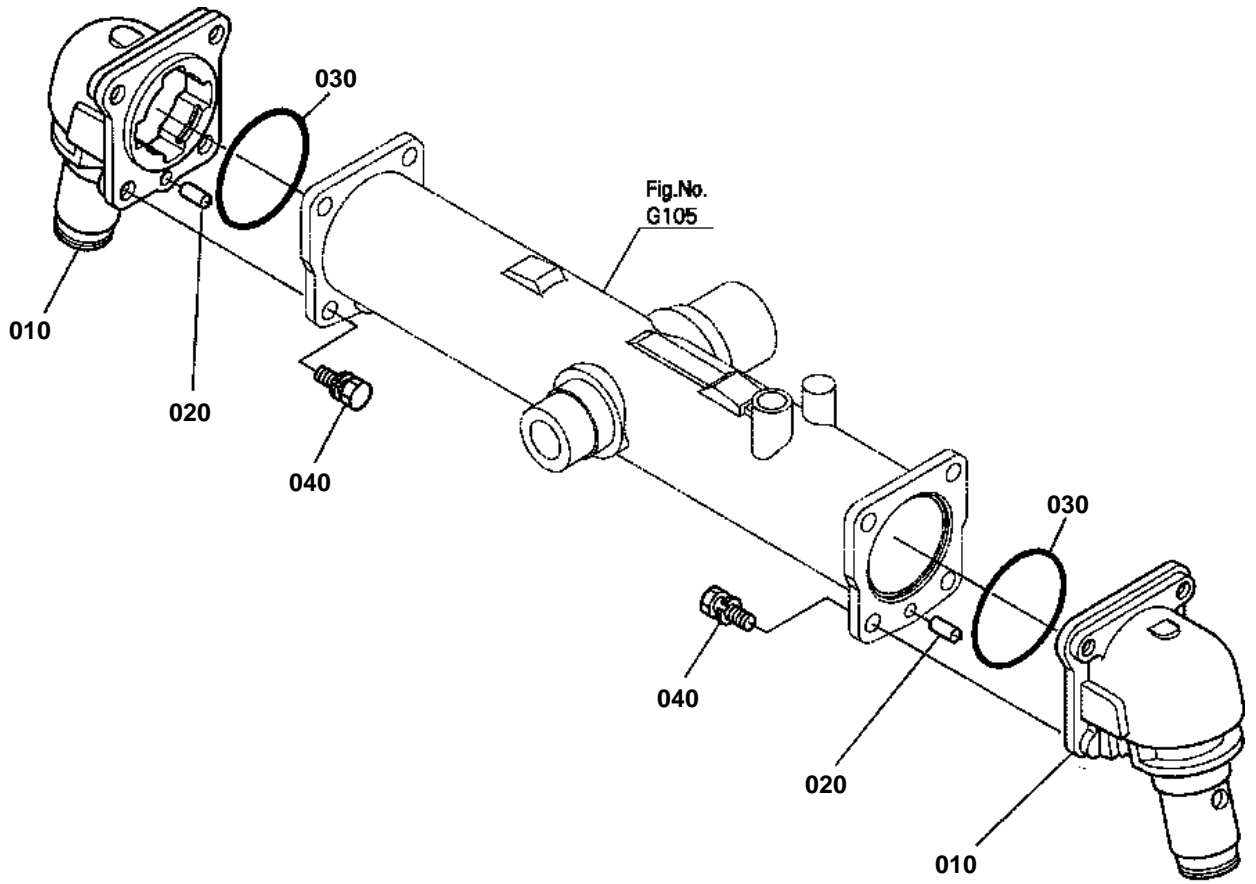

6C100-050-10

DRAG LINK

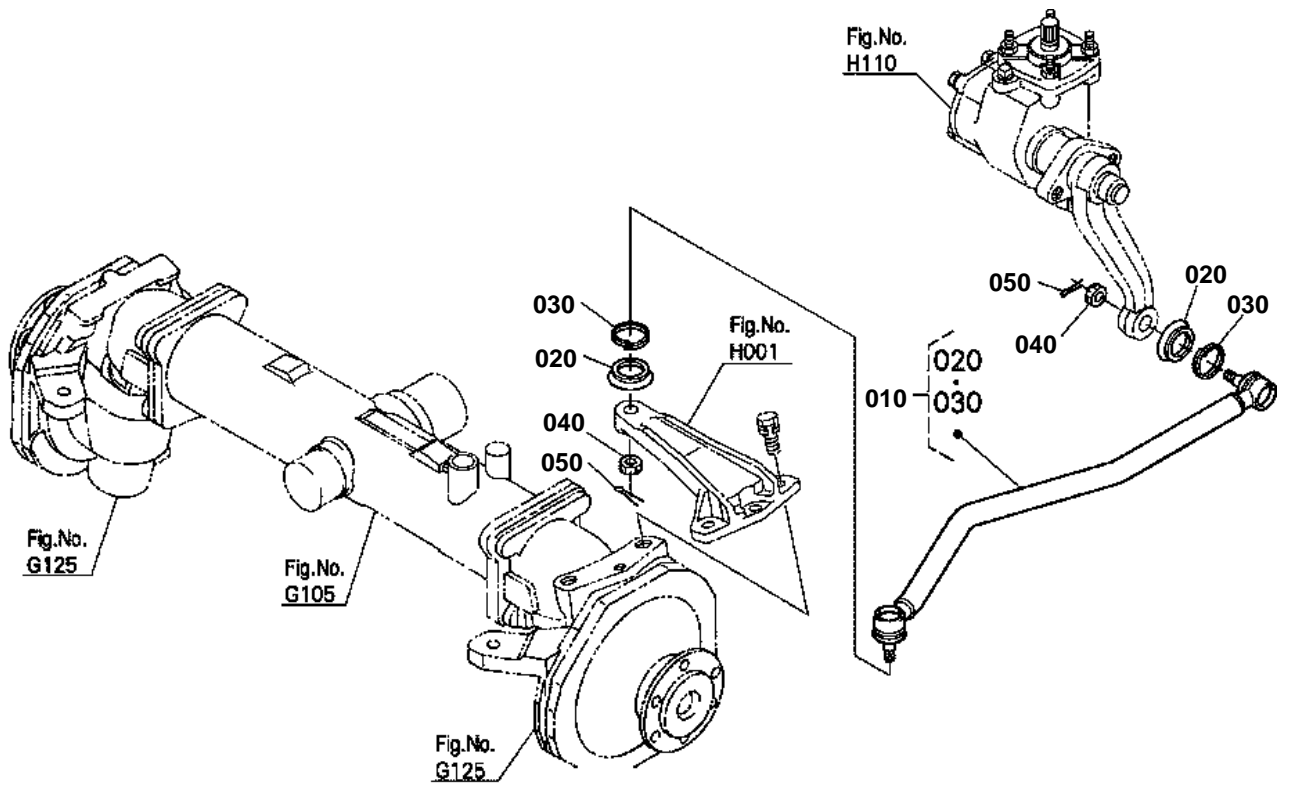

6C100-052-10

STEERING CONTROLLER [COMPONENT PARTS]

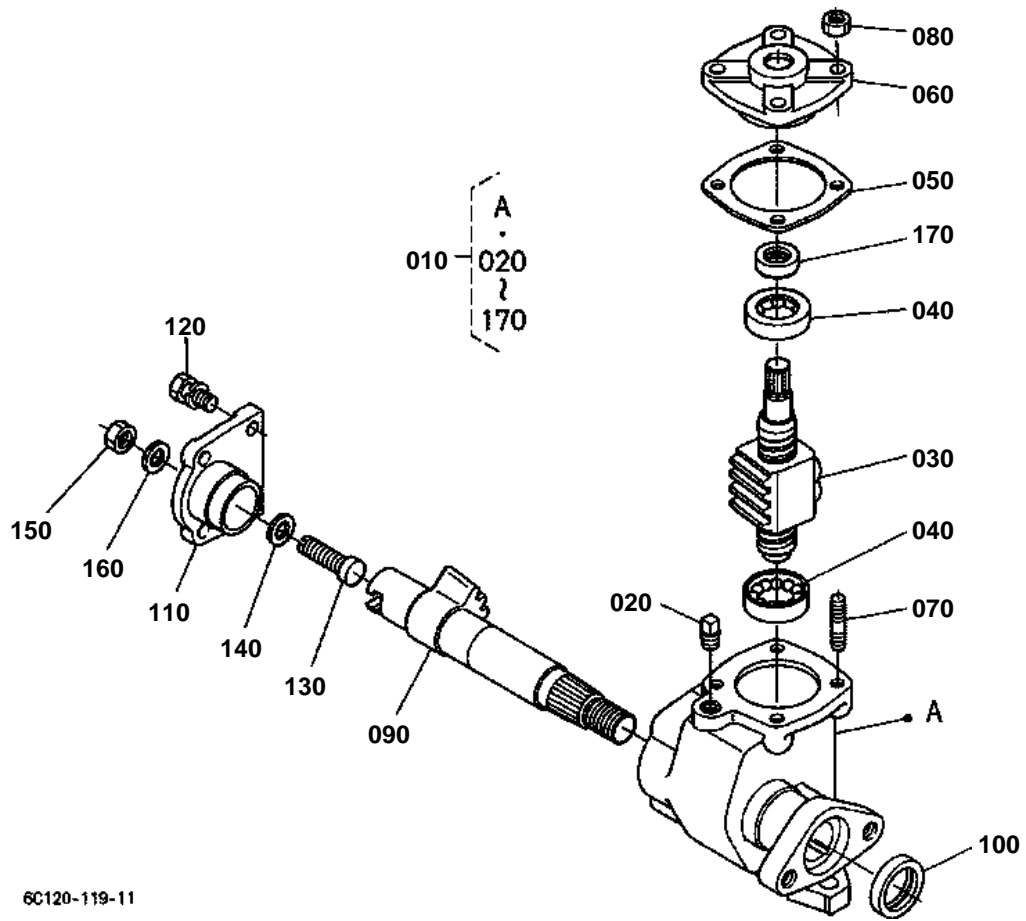

6C120-119-11

HYDRAULIC CYLINDER

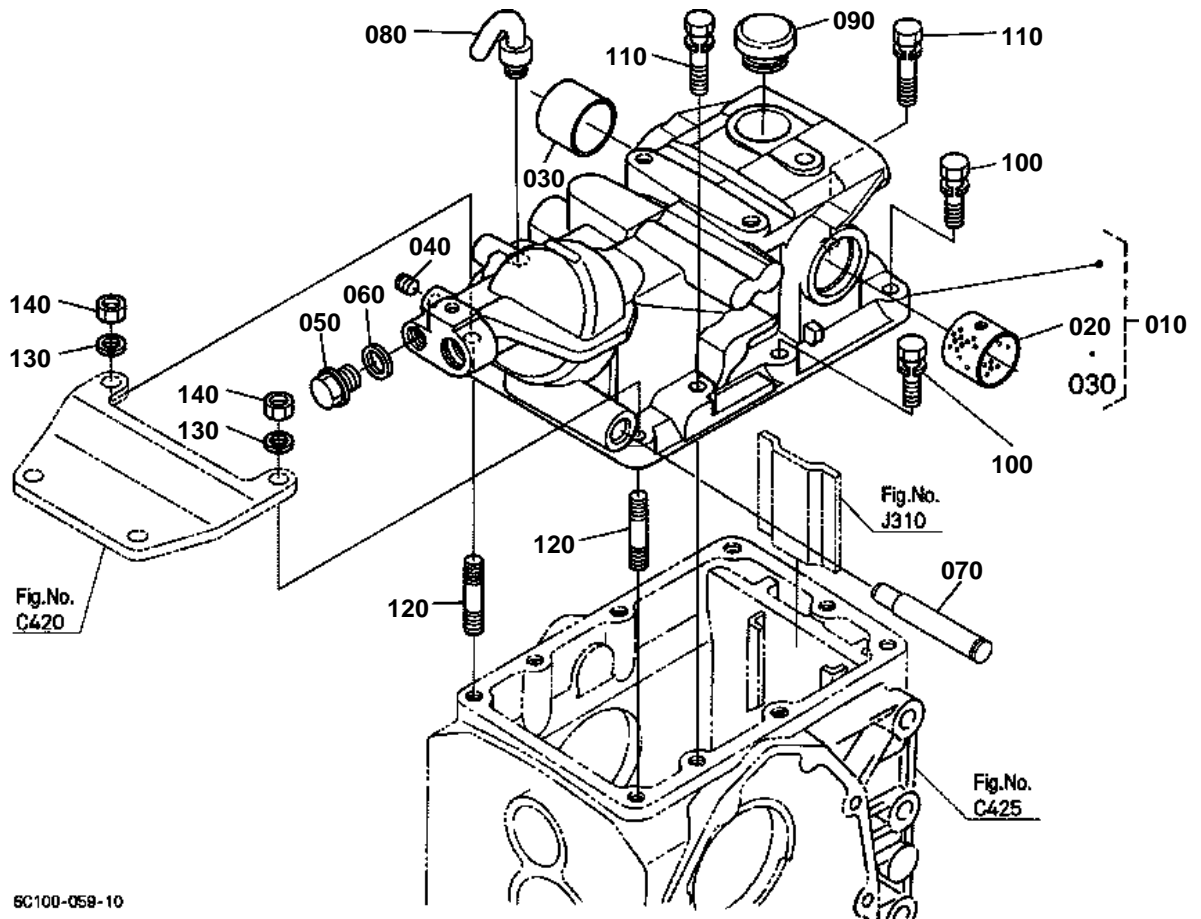

6C100-059-10

3-POINT LINKAGE 2(LIFT ROD)

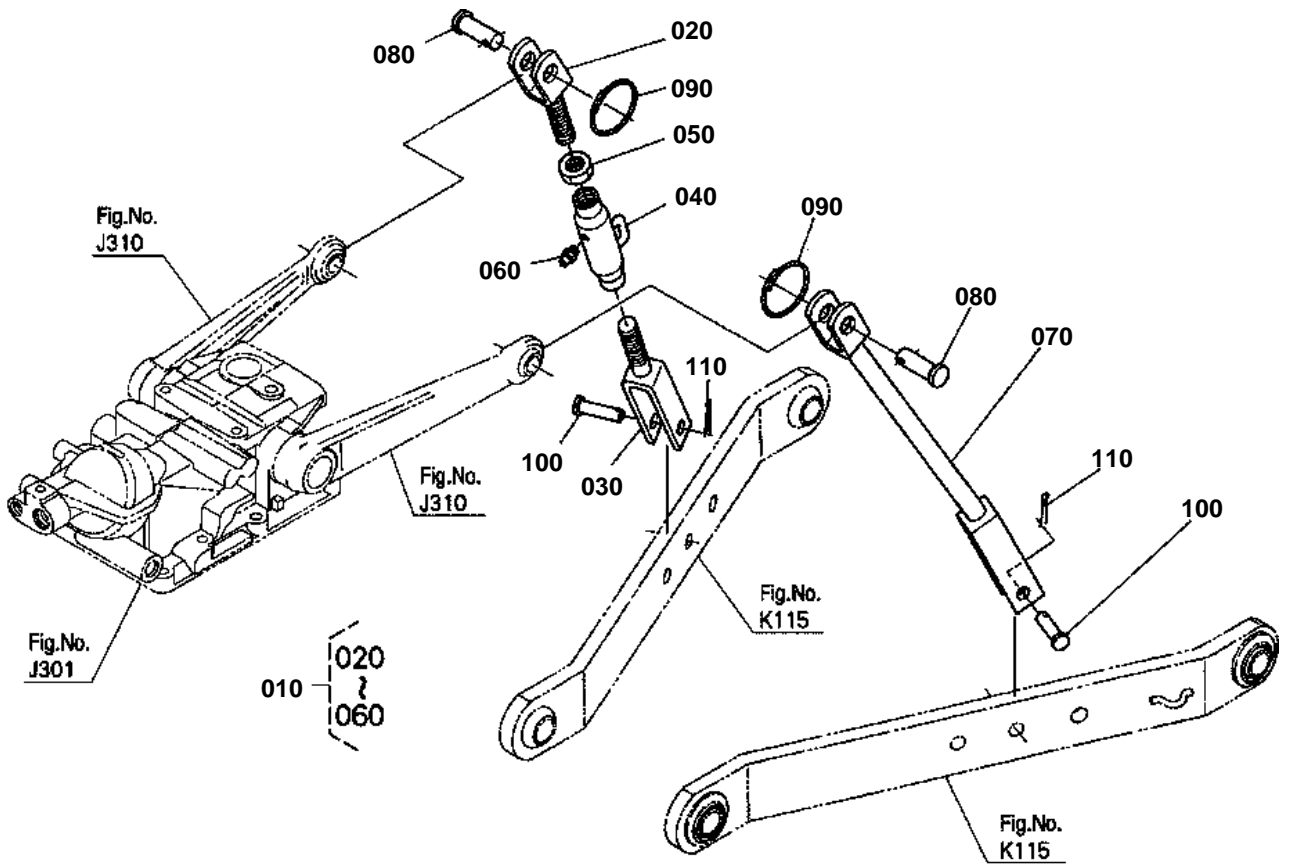

6C100-063-10

REAR HITCH

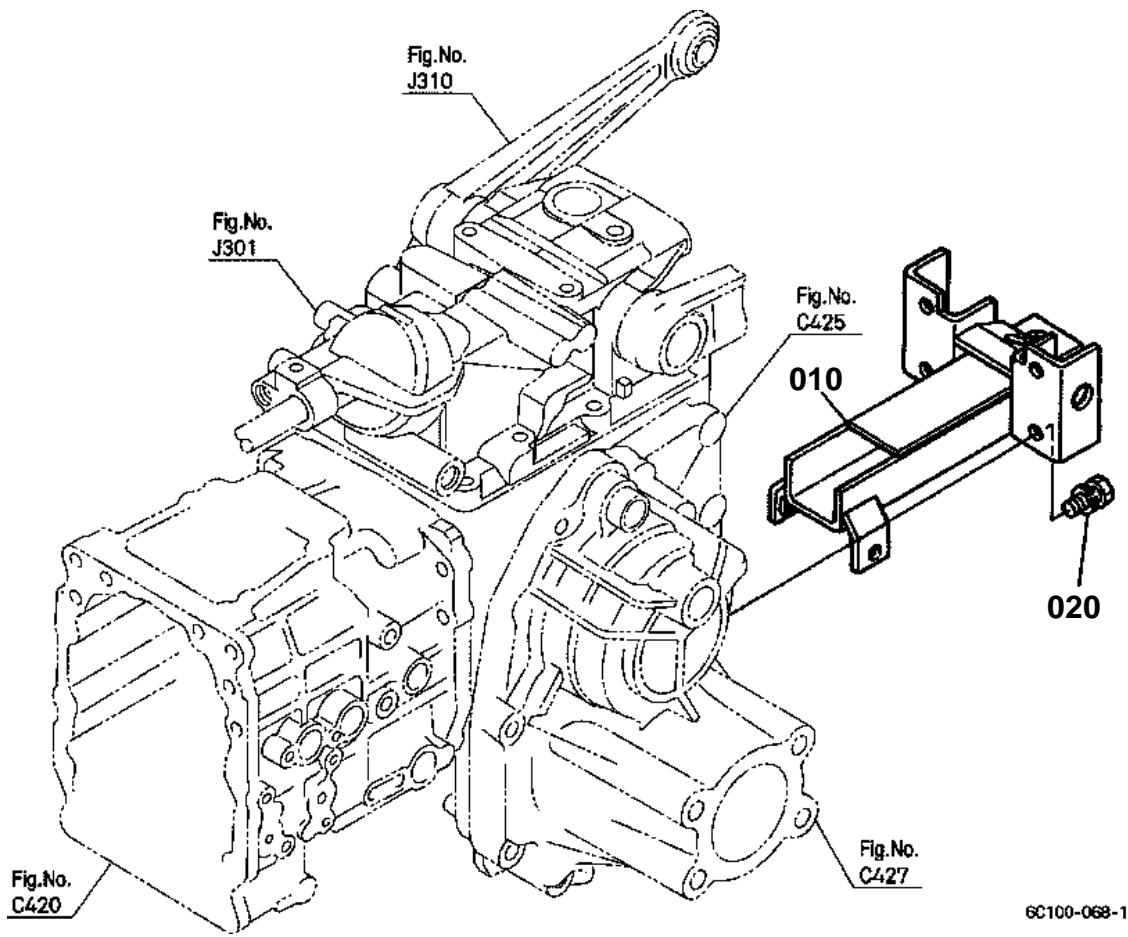



FRONT GRILLE [AU] [NZ]

↔ Interchangeable; ≠ not interchangeable; ← new for old; → old for new

REF.No	Part No.	Description	Q'ty	S.No.	I/C	REMARKS	Weight (kgf)	Weight (lb)
010	6C125-54402	COMP.COVER FRONT	1				1.14	2.508
020	6C125-54600	COMP.NET FRONT	1				1.06	2.332
030	6A325-54415	COVER FRONT	1				0.62	1.364
040	6C095-54430	NET	1				0.29	0.638
050	6C095-54630	CUSHION	1				0.04	0.088
060	6C095-54640	CUSHION	1				0.043	0.0946
070	6C095-54650	CUSHION	2				0.012	0.0264
080	6C045-54660	RIVET	20				0.001	0.0022
090	6C095-54620	STAY	2				0.02	0.044
100	6C040-54540	NUT	4				0.001	0.0022
110	6C090-54140	SPONGE	1				0.02	0.044
120	76611-53150	TRIM SHUTTER PLATE	2				0.04	0.088
130	6C090-47350	MARK	1				0.002	0.0044
140	6C090-47360	MARK	1				0.002	0.0044
150	37410-52610	SCREW KNOB	2				0.015	0.033



SHUTTER PLATE [AU] [NZ]

↔ Interchangeable; ≠ not interchangeable; ← new for old; → old for new

REF.No	Part No.	Description	Q'ty	S.No.	I/C	REMARKS	Weight (kgf)	Weight (lb)
010	6C100-54210	PILLAR CENTER	1				1.62	3.564
020	01133-51020	BOLT	2				0.02	0.044
030	6C090-54225	PILLAR CENTER	1				3.41	7.502
040	6C040-54610	BOLT	2				0.014	0.0308
050	6C090-54230	STAY PILLAR	1				0.355	0.781
060	01023-50616	BOLT	1				0.005	0.011
070	01023-50625	BOLT	1				0.007	0.0154
080	6A370-54280	BRACKET	1				0.11	0.242
090	6C090-54554	COVER HEAT PROOF	1				0.21	0.462
100	52300-26210	NUT	4				0.002	0.0044
110	6C090-54570	PLATE	1				0.072	0.1584
120	05525-50800	PIN SNAP	1				0.001	0.0022



FLOOR SEAT

↔ Interchangeable; ≠ not interchangeable; ← new for old; → old for new

REF.No	Part No.	Description	Q'ty	S.No.	I/C	REMARKS	Weight (kgf)	Weight (lb)
010	6C040-51370	COVER SEAT UNDER	1				0.38	0.836
020	01125-50818	BOLT	2				0.015	0.033
020	01125-60816	BOLT	2		<<		0.01	0.022



ROPS [AU]

↔ Interchangeable; ≠ not interchangeable; ← new for old; → old for new

REF.No	Part No.	Description	Q'ty	S.No.	I/C	REMARKS	Weight (kgf)	Weight (lb)
010	01123-51235	BOLT	10				0.041	0.0902
020	6C040-72210	COVER ROPS	2				0.066	0.1452
030	6A100-51380	CUSHION	2				0.003	0.0066
040	6C040-51342	BOLT	2				0.017	0.0374
050	6C140-54950	BRACKET SMV	1				0.85	1.87

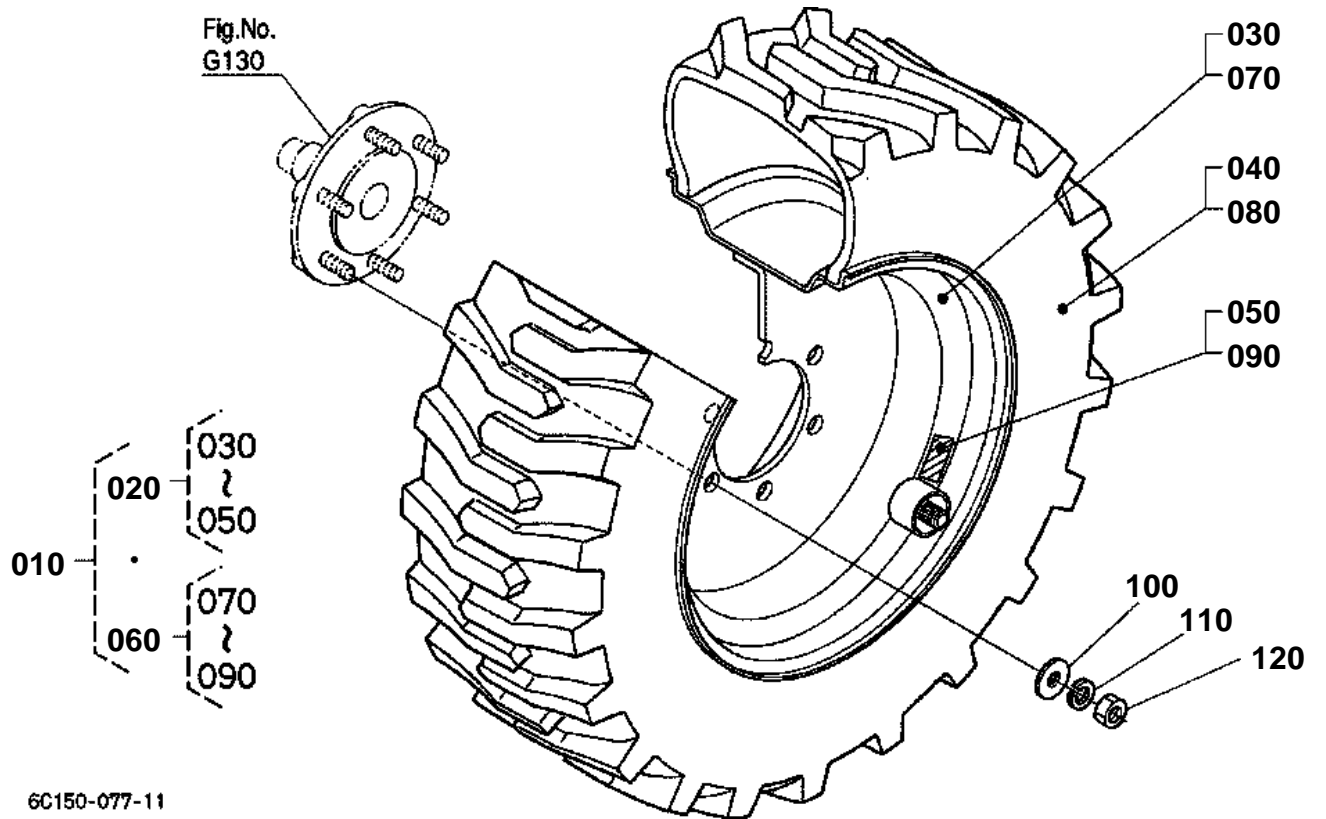

OLD PARTS

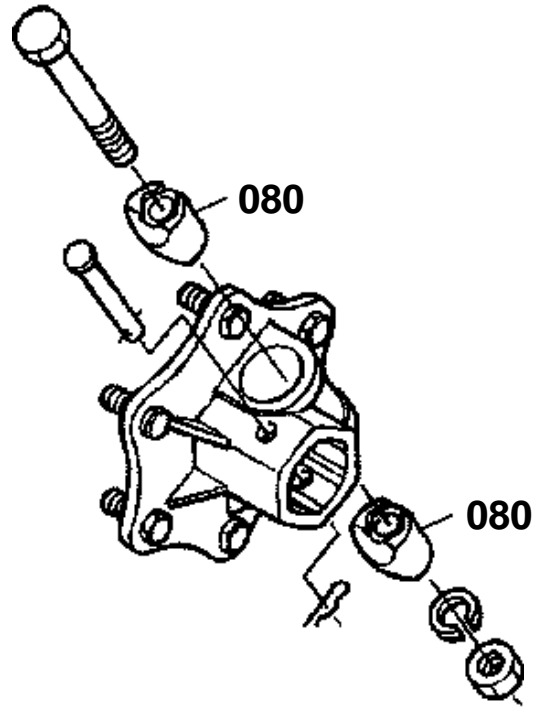

6C120-829-10



REAR WHEEL(9.5-16) [AU] [NZ]

↔ Interchangeable; ≠ not interchangeable; ← new for old; → old for new

REF.No	Part No.	Description	Q'ty	S.No.	I/C	REMARKS	Weight (kgf)	Weight (lb)
010	66416-17500	ASSY REAR WHEEL	1				63	138.6
020	66416-17510	ASSY REAR WHEEL LH	1				32	70.4
030	66416-17520	WHEEL	1				12.5	27.5
040	96019-12120	TUBE	1				1.8	3.96
050	96019-12130	TIRE	1				17.4	38.28
060	32150-27700	HOUSING VALVE CORE	1				0.001	0.0022
070	32150-27740	CORE VALVE	1				0.003	0.0066
080	38240-11690	CAP VALVE	1				0.001	0.0022
090	32270-27710	NUT RIM	1				0.006	0.0132
100	66416-17530	LABEL LH	1				0.001	0.0022
110	66416-17540	ASSY REAR WHEEL RH	1				32	70.4
120	66416-17520	WHEEL	1				12.5	27.5
130	96019-12120	TUBE	1				1.8	3.96
140	96019-12130	TIRE	1				17.4	38.28
150	32150-27700	HOUSING VALVE CORE	1				0.001	0.0022
160	32150-27740	CORE VALVE	1				0.003	0.0066
170	38240-11690	CAP VALVE	1				0.001	0.0022
180	32270-27710	NUT RIM	1				0.006	0.0132
190	66416-17550	LABEL RH	1				0.001	0.0022
200	6C040-17413	ASSY HUB WHEEL	2				2.6	5.72
210	66704-17313	BOLT	12				0.049	0.1078
220	6C040-17460	COTTER	4	<=30567		NOT SALE	0.17	0.374
220	6C190-17450	KIT COTTER	2	>=30568	-		0	0
230	01173-61600	BOLT	2	<=30567			0.165	0.363
230	01173-51695	BOLT	2	>=30568	1		0.016	0.0352
240	04512-60160	WASHER SPRING	2				0.01	0.022
250	02174-50160	NUT	2				0.022	0.0484
260	63733-17270	PIN WHEEL TUBE	2				0.05	0.11
270	62131-17290	PIN	2				0.003	0.0066
280	35340-11390	NUT	12				0.03	0.066
290	04512-60140	WASHER SPRING	12				0.008	0.0176
300	04013-60140	WASHER PLAIN	12				0.01	0.022

CLICK HERE TO **DOWNLOAD** THE COMPLETE MANUAL

- Thank you very much for reading the preview of the manual.
- You can download the complete manual from: www.heydownloads.com by clicking the link below



- Please note: If there is no response to CLICKING the link, please download this PDF first and then click on it.

CLICK HERE TO **DOWNLOAD** THE COMPLETE MANUAL