

REPAIR MANUAL 2003-2005

950 ADVENTURE
990 SUPER DUKE

REPARATURANLEITUNG
MANUALE DI RIPARAZIONE
MANUEL DE RÉPARATION
MANUAL DE REPARACIÓN

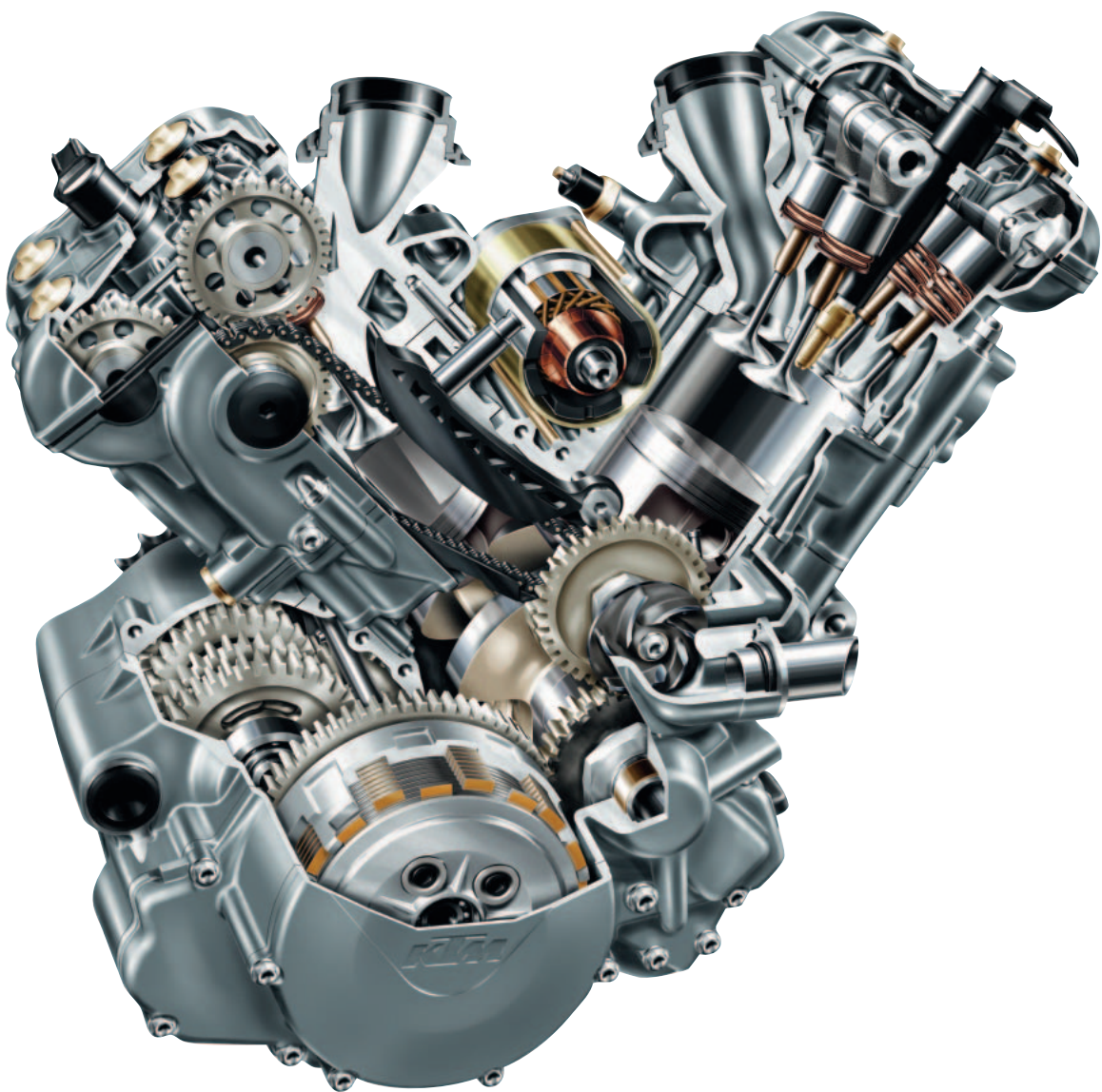

ART. NR.: 3.206.025-E

KTM

CLICK HERE TO **DOWNLOAD** THE COMPLETE MANUAL

- Thank you very much for reading the preview of the manual.
- You can download the complete manual from: www.heydownloads.com by clicking the link below



- Please note: If there is no response to CLICKING the link, please download this PDF first and then click on it.

CLICK HERE TO **DOWNLOAD** THE COMPLETE MANUAL

INTRODUCTION

This repair manual offers extensive repair-instructions and is an up-to-date version that describes the latest models of the series. However, the right to modifications in the interest of technical improvement is reserved without updating the current issue of this manual.

A description of general working modes common in work shops has not been included. Safety rules common in the work shop have also not been listed. We take it for granted that the repairs are made by qualified professionally trained mechanics.

Read through the repair manual before beginning with the repair work.

⚠ WARNING ⚠

STRICT COMPLIANCE WITH THESE INSTRUCTIONS IS ESSENTIAL TO AVOID DANGER TO LIFE AND LIMB.

! CAUTION !

NON-COMPLIANCE WITH THESE INSTRUCTIONS CAN LEAD TO DAMAGE OF MOTORCYCLE COMPONENTS OR RENDER MOTORCYCLES UNFIT FOR TRAFFIC !

„NOTE” POINTS OUT USEFUL TIPS.

Use only **ORIGINAL KTM SPARE PARTS** when replacing parts.

The KTM high performance engine is only able to meet user expectations if the maintenance work is performed regularly and professionally.



REG.NO. 12 100 6061

In accordance with the international quality management ISO 9001 standard, KTM uses quality assurance processes that lead to the highest possible product quality.

KTM Sportmotorcycle AG reserves the right to modify any equipment, technical specifications, colors, materials, services offered and rendered, and the like so as to adapt them to local conditions without previous announcement and without giving reasons, or to cancel any of the above items without substituting them with others. It shall be acceptable to stop manufacturing a certain model without previous announcement. In the event of such modifications, please ask your local KTM dealer for information.

KTM Sportmotorcycle AG
5230 Mattighofen, Austria

All design and assembly modification rights reserved.

© by KTM SPORTMOTORCYCLE AG, AUSTRIA

All rights reserved

SPECIALTOOLS – CHASSIS

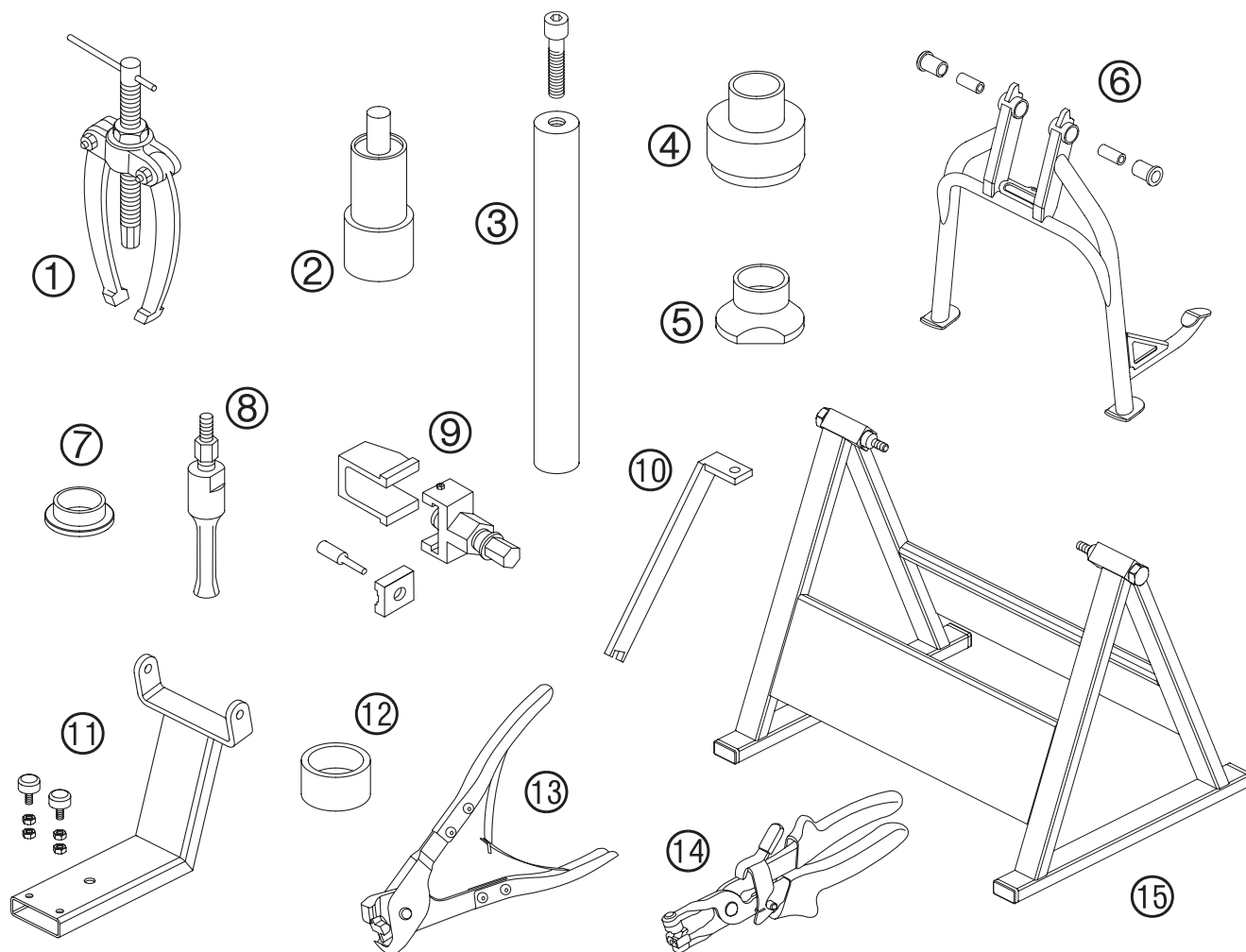

Art.-Nr. 3.206.025-E

Repair manual KTM LC8

FIG	PART NO	DESCRIPTION
1	151.12.017.000	Gear puller
2	584.29.086.000	Pressing tool for swing arm bearing
3	584.29.089.000	Chassis tool holder
4	584.29.091.000	Press-in tool for bearing seat / rear wheel bearing
5	584.29.092.000	Knock-out tool for bearing seat
6	600.03.022.000	Center stand
7	600.10.013.000	Sleeve for pressing tool for swim arm bearing
8	600.29.018.000	Internal gear puller 28 mm
9	600.29.020.000	Chain rivet tool
10	600.29.055.000	Center stand lock
11	600.29.055.100	Floor jack attachment
12	600.29.056.000	Anvil dolly (for 584.29.086.000)
13	600.29.057.000	Pliers for Öttiker clamps
14	600.29.057.100	Pliers for spring-loaded band-type clamp
15	610.29.055.000	Assembly stand 990 Super Duke

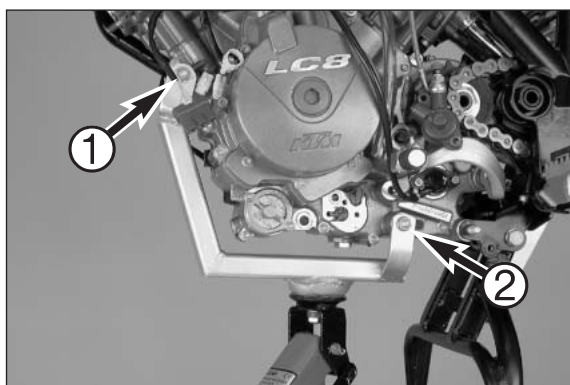

- Use the trolley jack to position the attachment 600.29.055.100 on the engine, insert the bolt ① through the front of the engine bracket and fasten with the nut. Screw one of the bolts ② on the rear of the side stand fixture and slightly lift the engine.

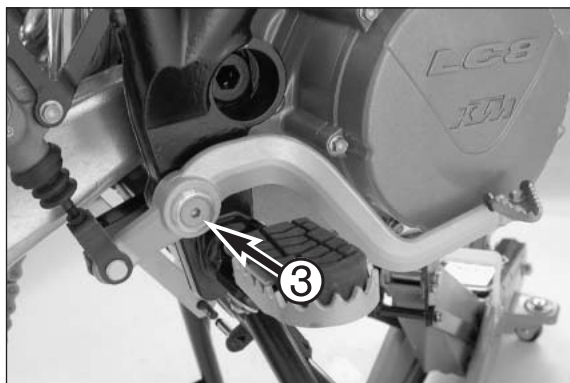

- Remove the bolt ③ and tilt the foot brake pedal to the side.

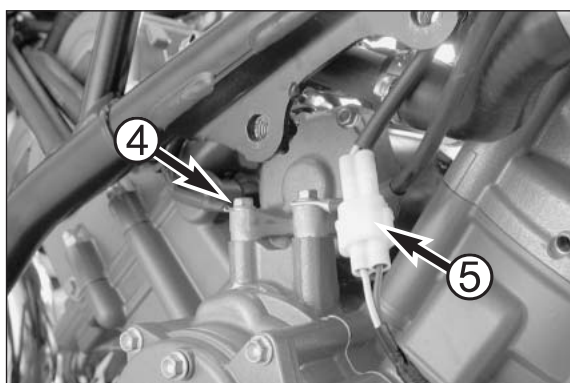

- Unscrew the ground wire connection ④.
- Detach the connector from the pulse generator ⑤.

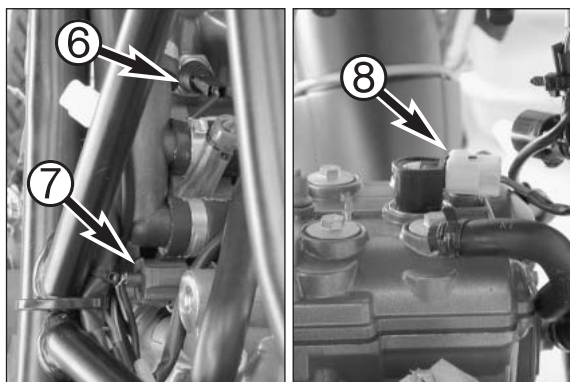

- Detach the connector from the oil pressure switch ⑥, the temperature sensor ⑦ and from the front ⑧ and rear ignition coil. Remove any cable clips necessary.

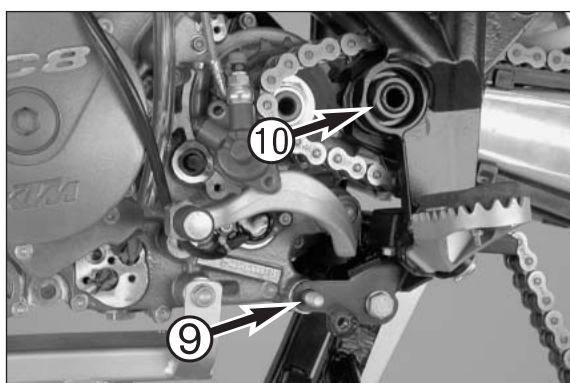

- Pull the bolt ⑨ out of the lower support (if necessary, raise or lower the engine slightly).
- Loosen the nut on the swing arm pivot ⑩ and knock out the swing arm pivot with a suitable pipe.
- Pull the engine towards the front with the trolley jack, lower and pull away towards the side.
- Disconnect all hoses and lines from the engine.

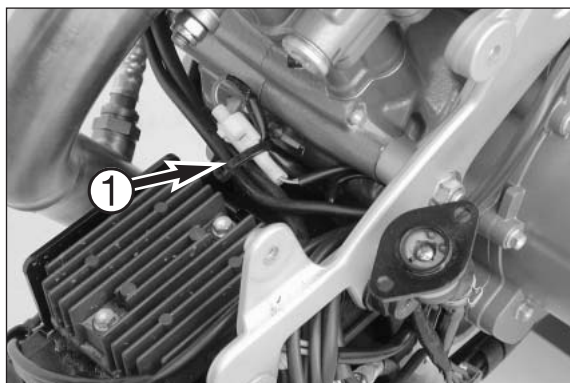

- Fasten the wiring harnesses and connector on the pulse generator **1** with cable clips.

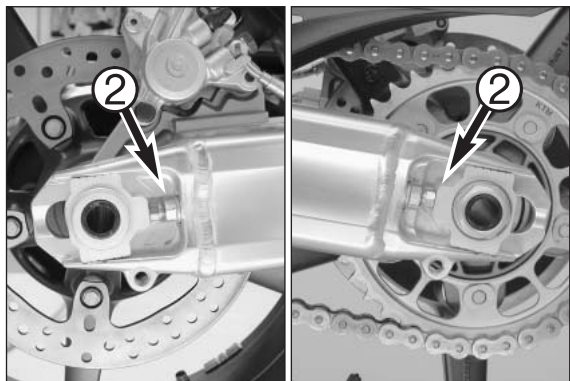

- Run the chain over the pinion and rear sprocket, raise the rear wheel and push the wheel spindle through.
- Push the rear wheel forward until the chain tensioner **2** rests against the stop screw and tighten the wheel spindle nut to 90 Nm.
- Actuate the foot brake lever until the brake pads rest against the brake disk again.
- Check the chain tension (see Owner's Manual).

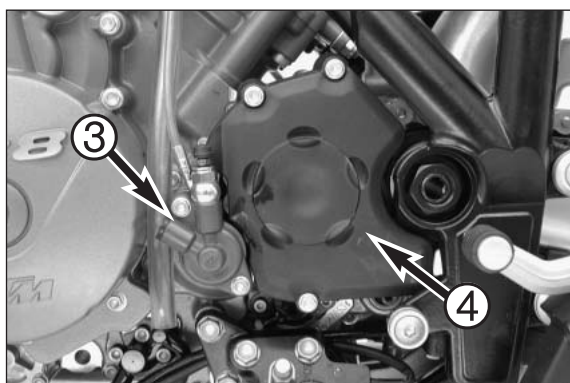

- Attach the lock pin to the pushrod and align with the recess in the chainguard. Mount the chain clip and the chainguard.
- Mount the clutch slave cylinder **3** and screw on the chainguard **4**.

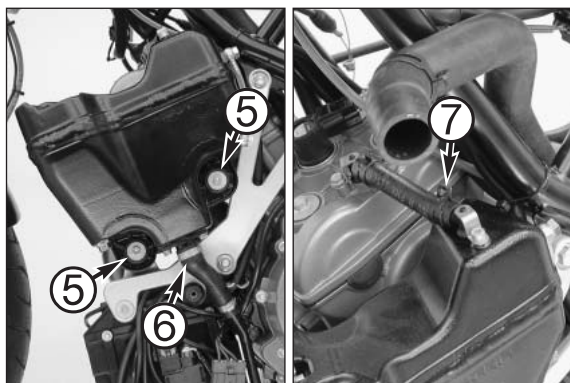

- Mount the oil tank and tighten the fixing screws **5**.
- Mount the suction line **6** with a new O-ring.
- Connect the oil lines from the oil tank to the valve covers **7** (special pliers 600.29.057.100).
- Connect the return line **8** to the oil tank and mount the spring-loaded band-type clamps with the special pliers 600.29.057.100.

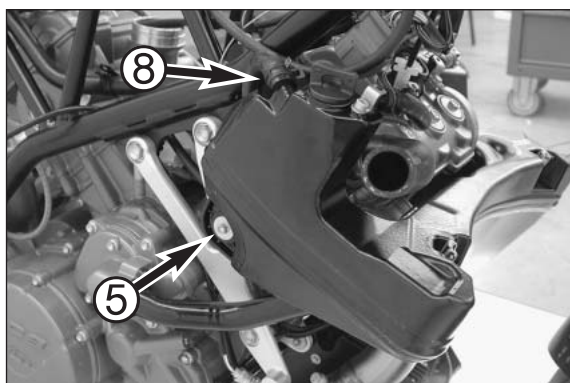

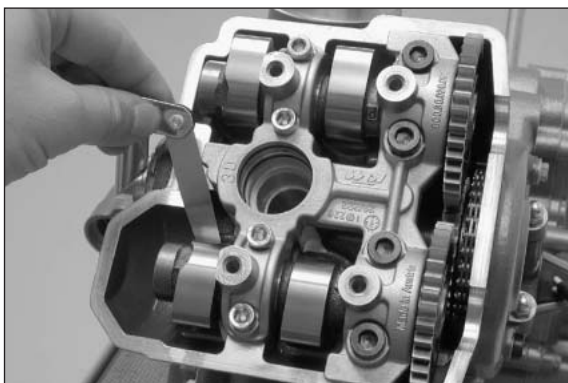

Camshafts cylinder front

- Check and note down the valve clearance before you dismount the camshafts.

Valve clearance (at 20°C): intake 0.10 - 0.15 mm
exhaust 0.25 - 0.30 mm

- Loosen the bolts on the camshaft bearing bridge from the front cylinder and carefully remove the camshaft bearing bridge.

! CAUTION !

WHEN TIGHTENING THE BOLTS OF THE CAMSHAFT BEARING BRIDGE, MAKE SURE THAT THE VALVES ARE NOT ACTUATED BY THE CAMSHAFT (SEE ILLUSTRATION), OTHERWISE THE BEARING BRIDGE WILL BREAK.

- Remove the camshafts from the cylinder head without tilting.

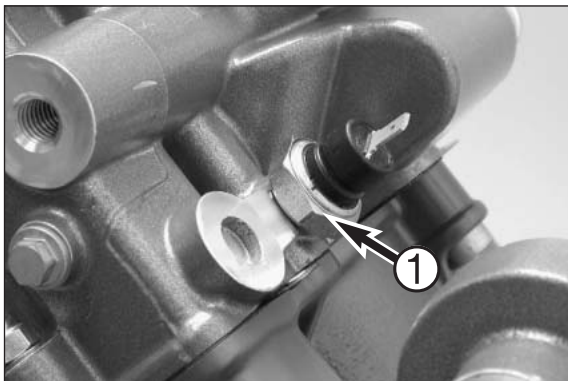

Oil pressure switch

- Loosen the oil pressure switch ❶ and unscrew. Discard sealing washer.

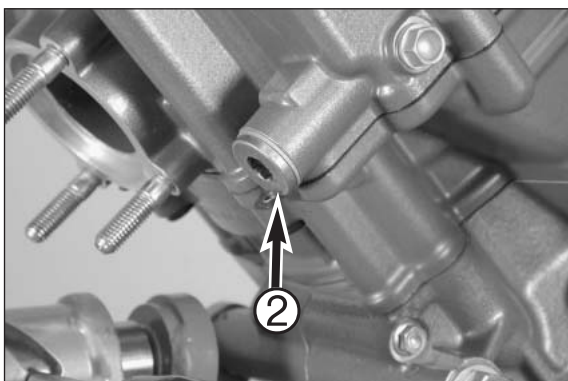

Chain tensioner cylinder front

- Remove the bolt on the chain tensioner ❷.

NOTE: measure the preload on the chain tensioner element before dismounting:

- Apply the chain tensioner bolt to the chain tensioner element without compressing the spring.
- Measure the distance between the sealing washer and the cylinder head.

The measured value should be between 6 mm and 11 mm. If the value is lower, the tensioning rail could be worn or the timing chain excessively elongated. If it is higher, the engine was turned to TDC against the running direction.

- Remove the sealing washer.

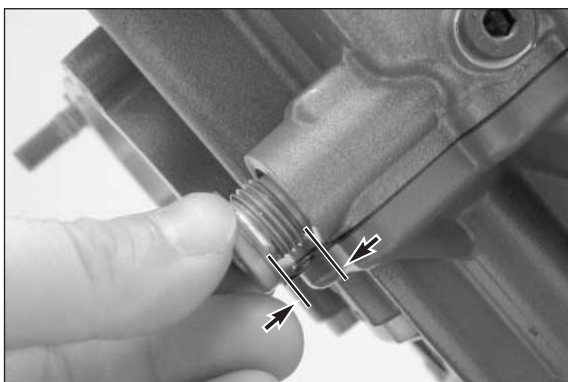

- Pull out the chain tensioner element ❸.

NOTE: the housing and the tensioning piston on the chain tensioner element are compression molded. If they fall apart during disassembly, the chain tensioner element must be replaced.

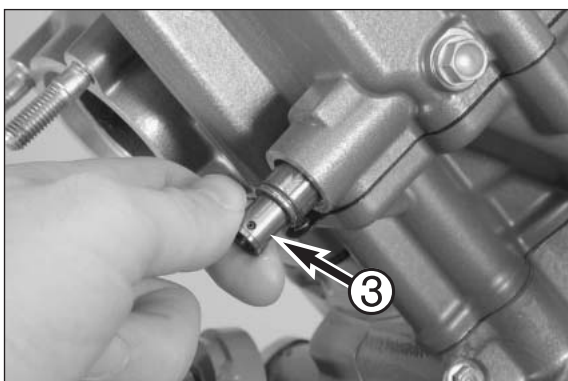

SERVICING INDIVIDUAL COMPONENTS

5

INDEX

ROLLER BEARING	5-2
MAIN BEARINGS - GENERAL INFORMATION	5-3
REPLACING BEARING SHELLS, OUTPUT END	5-4
REPLACING BEARING SHELLS, GENERATOR END	5-4
REPLACING THE CONROD BEARINGS	5-5
SELECTING THE BEARING SHELLS	5-5
REPLACING THE SUPPORTING BEARINGS IN THE CLUTCH COVER	5-6
OVERHAULING THE WATER PUMP	5-7
CHECKING THE SUCTION PUMP FOR WEAR	5-8
CHECKING THE PRESSURE PUMP FOR WEAR	5-8
BYPASS VALVE	5-8
DISASSEMBLING THE CYLINDER HEAD AND CHECKING	
PARTS FOR WEAR	5-9
CHECKING THE PISTONS	5-10
ASSEMBLY INSTRUCTIONS FOR PISTON RINGS	5-10
CHECKING THE PISTON RING END GAP	5-10
MEASURING PISTONS + CYLINDERS, ESTABLISHING THE PISTON	
MOUNTING CLEARANCE	5-10
PISTON AND CYLINDER IDENTIFICATION	5-11
ASSEMBLING THE CYLINDER HEAD	5-11
GENERATOR COVER	5-13
TORQUE LIMITER	5-13
VALVE GEAR – CHECKING PARTS FOR WEAR	5-13
PREASSEMBLING THE SPREADER	5-14
CLUTCH – CHECKING PARTS FOR WEAR	5-15
SHIFT MECHANISM – CHECKING PARTS FOR WEAR	5-16
PREASSEMBLING THE SHIFT SHAFT	5-16
GENERAL INFORMATION ON SERVICING THE TRANSMISSION	5-17
ASSEMBLING THE MAIN SHAFT	5-17
ASSEMBLING THE COUNTERSHAFT	5-18
CHECKING THE FREEWHEEL	5-19
REPLACING THE FREEWHEEL HUB	5-19
STARTER	5-19

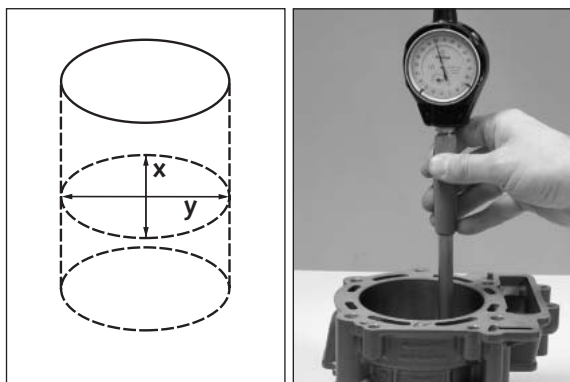
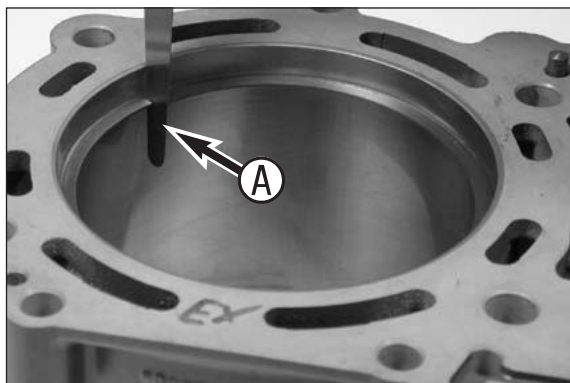
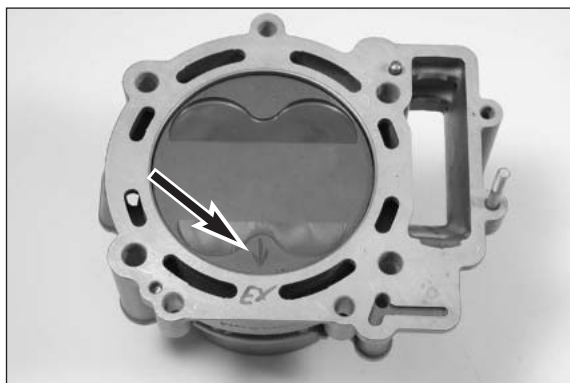

Checking the pistons

- Mark the position of the piston arrow in the cylinder to facilitate reassembly and to ensure that the same piston is mounted in the same cylinder again.
- Press the piston up out of the cylinder.
- Replace the piston if oil consumption is high or the piston skirt is excessively grooved.
- If the piston is to be reinstalled:

1. Check the piston bearing surface for damage.
2. Piston ring grooves: the piston rings must move freely in the groove. Use old piston rings or sandpaper (400 grit) to clean the piston ring grooves.
3. Check the piston rings for damage and end gap.
4. The piston pins must move freely in the bolt hole when mounted. Replace piston pins that are badly discolored or have visible running marks. Place the piston pin in the conrod and check for clearance. Maximum clearance in the conrod eye: 0.08 mm.

NOTE: the piston pin may not have any clearance when mounted and should be easy to move when applying slight counterpressure.

Checking the piston ring end gap

- Insert the piston ring in the cylinder and align with the piston (approx. 10 mm under the upper edge of the cylinder).
- Measure the end gap with a feeler gauge (A).

Piston ring end gap: max. 0.50 mm

If the end gap is larger than indicated above, check the cylinder for wear. If the cylinder wear is within the tolerance limits, replace the piston ring.

Assembly instructions for piston rings

- Mount the oil scraper ring in the lower piston ring groove with the mark facing the piston head.
- Mount the compression ring in the middle piston ring groove with the mark facing the piston head.
- Mount the compression ring in the upper piston ring groove with the mark facing the piston head.

Measuring pistons and cylinders, establishing the piston mounting clearance

- To establish cylinder wear, use a micrometer to measure the cylinder in the middle of the bearing surface.
- Measure the X and Y axis of the cylinder diameter to establish any ovality.

NOTE: if the Nicasil coating on the cylinder is worn but not damaged, a replacement cylinder can be ordered from our KTM dealer/importer (new Nicasil coating, used cylinder).

- Measure the piston at the piston skirt across the piston pin, 9 mm from the lower edge.

950 Adventure:

Piston size I: 99.953 mm – 99.967 mm
 Piston size II: 99.963 mm – 99.977 mm
 Wear limit: 99.930 mm

990 Super Duke:

Piston size I: 100.943 mm – 100.957 mm
 Piston size II: 100.953 mm – 100.967 mm
 Wear limit: 100.930 mm

- The piston mounting clearance is the difference between the smallest cylinder diameter and the piston diameter.

Piston mounting clearance 950 Adventure: 0.04 mm – 0.06 mm
 Wear limit: 0.10 mm

Piston mounting clearance 990 Super Duke: 0.05 mm – 0.07 mm
 Wear limit: 0.10 mm

ASSEMBLING THE ENGINE

6

INDEX

OIL PUMPS	6-2
TRANSMISSION	6-4
CASE HALF	6-5
SHIFT MECHANISM	6-6
ALIGNING THE RETURN SPRING	6-6
BALANCER SHAFT	6-7
FREEWHEEL	6-7
ROTOR	6-7
GENERATOR COVER	6-8
TIMING CHAIN AND BALANCING WEIGHT	6-8
PRIMARY PINION	6-9
OUTER CLUTCH HUB	6-9
CLUTCH DISKS	6-10
CLUTCH COVER	6-11
OIL SCREEN	6-12
WATER PUMP	6-12
CYLINDER HEAD REAR WITH TIMING CHAIN	6-13
CHAIN TENSIONER CYLINDER REAR	6-15
CAMSHAFTS CYLINDER REAR	6-16
SETTING CYLINDER FRONT TO TDC	6-17
CYLINDER HEAD FRONT WITH TIMING CHAIN	6-17
CHAIN TENSIONER CYLINDER FRONT	6-19
OIL PRESSURE SWITCH	6-19
CAMSHAFTS CYLINDER FRONT	6-20
STARTER MOTOR	6-21
SPARK PLUG SHAFT INSERTS	6-22
VALVE COVER	6-22

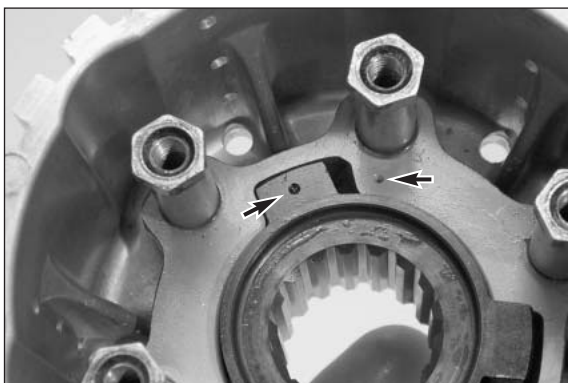

- Slide the 25 x 48 x 6.5 mm disk and inner clutch hub together with the clutch pressure booster onto the main shaft teeth.

NOTE: the two clutch pressure booster parts are marked with coinciding circles.

- Attach the holder for the inner clutch hub **A** 600.29.003.000. Mount the 22 x 37 x 3 mm disk. Apply Loctite 243 to the nut (32 mm) and tighten to 130 Nm. Remove support.
- Turn the inner clutch hub to check for smooth operation.

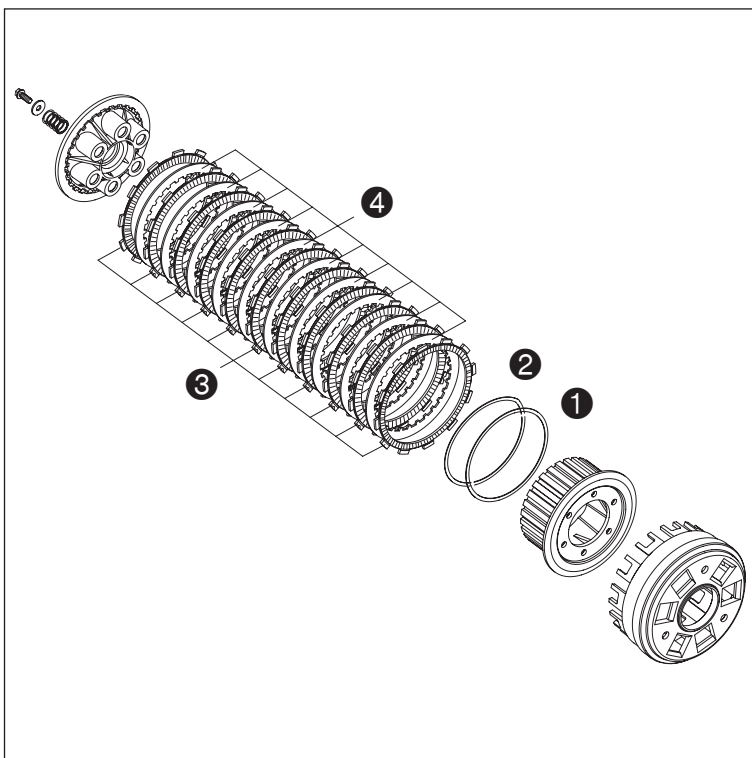
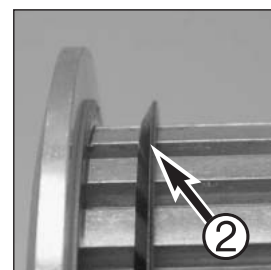
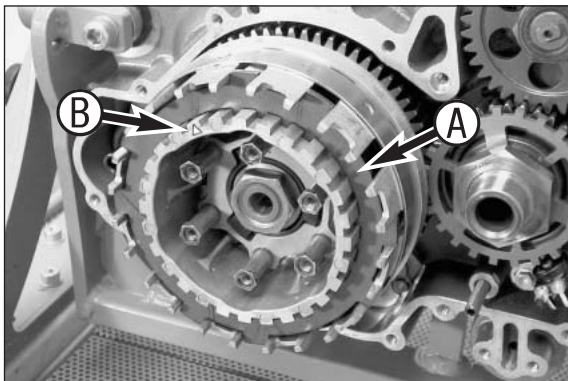

Clutch disks

- First mount the supporting plate **1** and then the spring washer **2** with the open side facing outwards (see illustration).
- Starting with the lining disk **3** with the largest inner diameter, alternately insert 11 lining disks and 10 clutch disks.

NOTE:

- Thoroughly oil all disks.
- The clutch lining on the first and last clutch disks have a different color since these two disks run on aluminum on one side.
- The first clutch disk has a larger inner diameter to hold the support and lining disk.
- The clutch disks are punched out. The sharp edges on all of the disks must point in the same direction. The round recesses (for demounting) must be in the same meshing.
- The last lining disk must be turned one meshing further.

- Push the clutch pushrod into the transmission main shaft.
- The marks **B** on the pressure cap and inner clutch hub must coincide when the pressure cap is mounted.
- Mount the pressure springs with disks and bolts (M6x16). Tighten the bolts crosswise to 10 Nm.

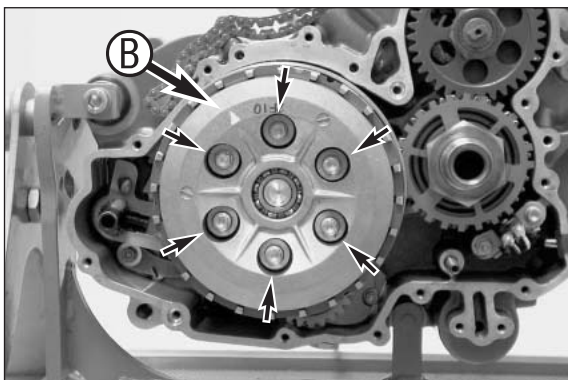

Camshafts cylinder front

- Insert the two camshafts marked "in fr" (front intake camshaft) and "ex fr" (front exhaust camshaft) into the bearings without tilting. The marks on the camshaft gears must coincide with the cylinder head surface (see illustrations).

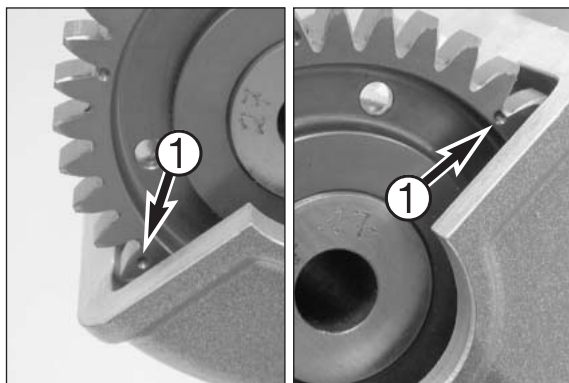

NOTE:

- The same camshaft gears are used in both cylinders but they have marks for cylinder rear and front. Use the camshaft gear marked with a cross for cylinder rear and the camshaft gear marked with a circle 1 for cylinder front.
- The cams 2 of both camshafts on the cylinder front will point towards the outside in the TDC position.
- The camshaft bearing bridges 3 and the cylinder heads 4 have coinciding marks to ensure that the same camshaft bearing bridge is mounted on the same cylinder head.

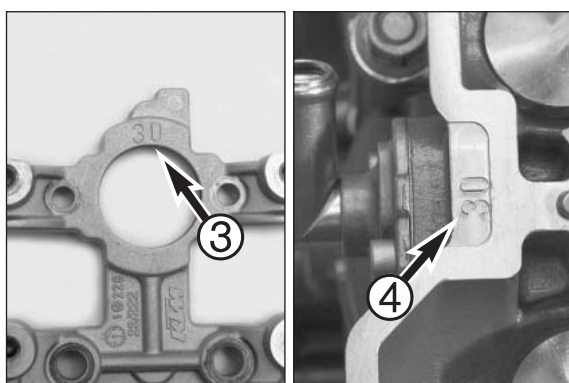
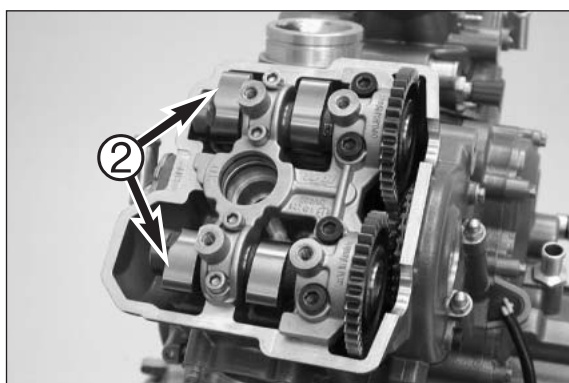

- Place plastiguage measuring strips 5 (600.29.012.000) on the camshaft bearing positions.
- Carefully mount the camshaft bearing bridge and tighten the bolts in the camshaft bearing bridge to 10 Nm (M8) in the first stage.
- Tighten to 18 Nm (M8) and 10 Nm (M6) in the second stage.

! CAUTION !

WHEN TIGHTENING THE BOLTS OF THE CAMSHAFT BEARING BRIDGE, MAKE SURE THAT THE VALVES ARE NOT ACTUATED BY THE CAMSHAFT (SEE ILLUSTRATION), OTHERWISE THE BEARING BRIDGE WILL BREAK.

NOTE: do not turn the camshafts.

- Remove the camshaft bearing bridge again and compare the width of the plastiguage measuring strip 6 with the information on the packing. The width of the plastiguage measuring strip is equivalent to the bearing clearance.

Camshaft bearing clearance: 0.020 mm – 0.061 mm
Wear limit: 0.09 mm

- Carefully mount the camshaft bearing bridge and tighten the bolts in the camshaft bearing bridge to 10 Nm (M8) in the first stage.
- Tighten to 18 Nm (M8) and 10 Nm (M6) in the second stage.

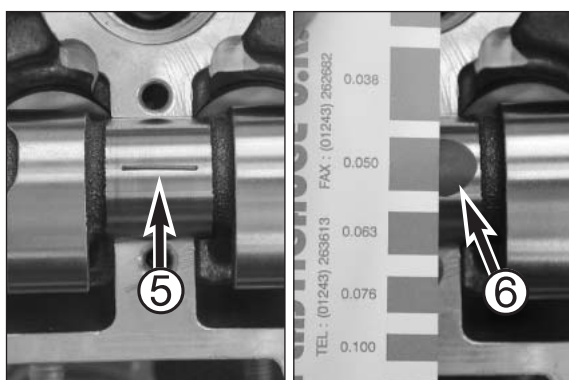

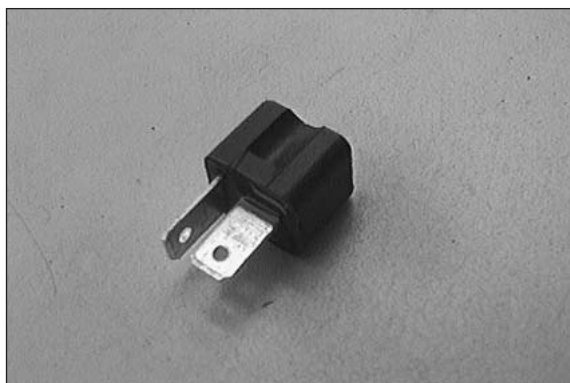
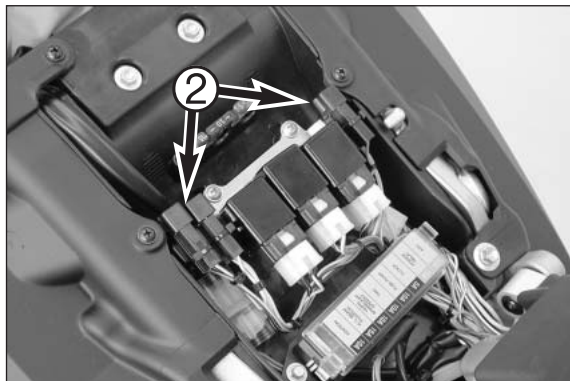
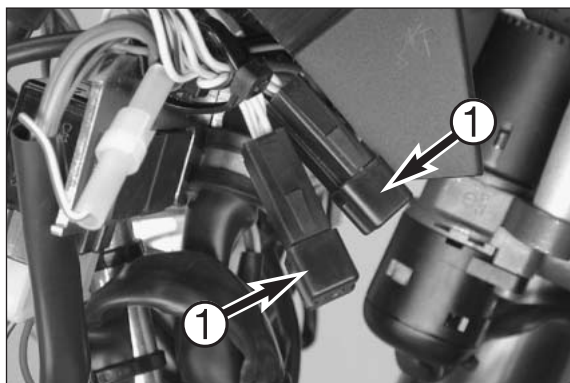

Checking the diodes

NOTE: Diodes only conduct the current in one direction. They block in the other direction.

Diodes can have 2 defects:

- the diode has no continuity.
- the diode has continuity in both directions.

Various malfunctions can occur, depending on the type of defect.

Each diode ❶ (950 Adventure) and ❷ (990 Super Duke) is plugged into a bipolar connector (connector AI)

Functional check:

- Connect a suitable ohmmeter to the diode and check the diode for continuity.
- Connect the ohmmeter in the other direction and check if the diode is blocked.

Checking the starter relay

- Disconnect the negative pole from the battery and dismount the start relay.

NOTE: white/red and brown cable colors ❸ and ❹ (950 Adventure) or ❺ and ❻ (990 Super Duke).

- Connect the starter relay to a 12 V battery, making sure you hear the relay switch (nonrecurring "click").

NOTE: the 12 V battery must be connected to the same terminals to which the 3 white/red and the brown cable are connected when the connector is attached.

- Check the continuity between the two screw terminals with an ohmmeter.

Reading: max. 1 Ω OK

Reading: $\infty \Omega$ defective

- Remove the fuse for the start relay and check for continuity.

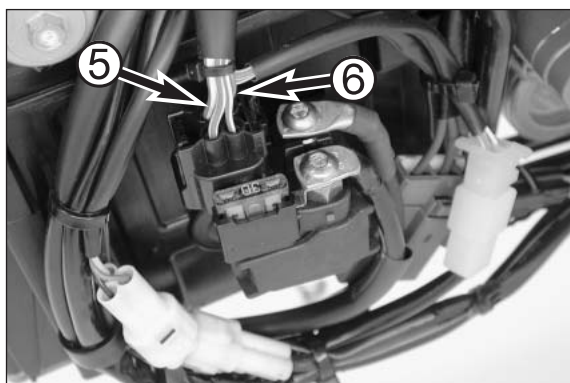
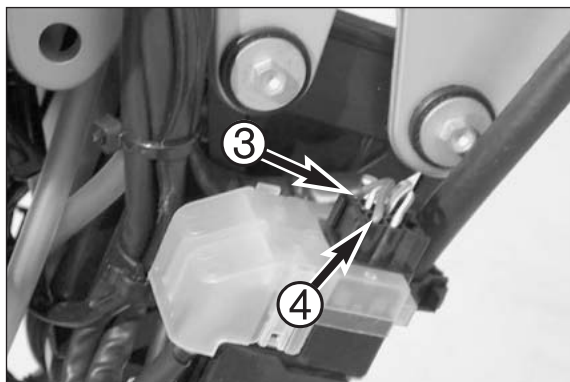

BASIC DESCRIPTION OF THE SYSTEM

Fuel system:

Fuel is drawn in by the fuel pump via the fuel screen and pumped through the fuel filter to the pressure regulator. All of these components are located in the tank.

Since the fuel pump's flow rate and flow pressure are considerably higher than required by the injection system, a constant pressure of 343 kPa (3.5 bar) is selected by means of the pressure regulator. The excess fuel returns to the fuel tank unpressurized.

The pressurized fuel flows from the pressure regulator to the injection valves and is injected into the induction manifold when the injection valves are opened (induction manifold or indirect injection).

The system does not require an external return line since the pressure regulator is installed in the tank.

Injection:

The injection nozzles are controlled by the control unit based on the pressure conditions in the induction manifold (manifold air pressure sensors) and the rotational speed (pulse generator), taking the corrective injection periods into account (see above) - this applies to the lower load/speed range. The opening of the injection nozzles is calculated according to the speed and throttle valve signals at higher loads or speeds.

The injection is sequential, i.e. each injection nozzle is individually controlled and the fuel injected into the intake port of the respective cylinder.

Ignition:

The ignition is also controlled by the ECU using a conventional transistor ignition system. Both the ignition timing and the closing angle are calculated according to a stored map.

The ignition timing is established based on the following information: rotational speed, position of the throttle valve, the coolant temperature and the operating condition (idle/not in idle).

Idle control:

The control unit controls the idle speed depending on the cooling liquid temperature by opening the throttle valve wider or less wide with the idle speed control motor.

Trailing throttle fuel cutoff:

If the driver closes the throttle valve with the engine running at operating temperature at a speed of at least 5000 rpm (overrun condition, i.e. the motorcycle is driving the engine), the control unit will interrupt the control of the injection valves until the minimum speed drops below 5000 rpm. Purpose: to save fuel and improve exhaust emissions.

Speed limitation:

To avoid damage to the engine, the control of the injection nozzles is cut off at speeds exceeding 9600 rpm and the ignition coils cut off at speeds exceeding 10100 rpm.

Secondary air control:

Fresh air is introduced into the exhaust through a valve during the warm-up stage to improve the emission quality and to reduce the catalytic converter light-off time. Afterburning takes place.

Lambda control:

A lambda probe (one probe per cylinder) is used to find the ideal fuel/air ratio for the best possible combustion (at a mixture ratio of 1 kg fuel and 14.7 kg air). The catalytic converter installed in the exhaust can operate at maximum efficiency (at a maximum conversion rate).

The goal is to obtain the maximum lambda 1 air ratio, i.e. to make the air volume actually drawn in by the engine equivalent to the air volume theoretically required (to burn the quantity of injected fuel).

If the quantity of drawn-in air is smaller (i.e. air deficiency), the mixture is rich (lambda less than 1).

If the quantity of drawn-in air is greater (i.e. excess air), the mixture is lean (lambda greater than 1).

Electronic power control (EPC):

Under certain operating conditions, the second throttle is controlled in accordance with the throttle valve position and speed.

Error detection/elimination:

An "FI" error lamp is installed in the multifunctional digital speedometer that lights up for 2 seconds after "Ignition on" (function indicator) and goes out if the control unit fails to detect any errors.

The error lamp will stay on during operation if an error is detected; if the vehicle is standing (gear in neutral) the error lamp will start to blink according to the respective error code.

The registered error codes can be read out through the diagnostics connector using the KTM diagnostics tool and deleted after the error has been eliminated.

CLICK HERE TO **DOWNLOAD** THE COMPLETE MANUAL

- Thank you very much for reading the preview of the manual.
- You can download the complete manual from: www.heydownloads.com by clicking the link below



- Please note: If there is no response to CLICKING the link, please download this PDF first and then click on it.

CLICK HERE TO **DOWNLOAD** THE COMPLETE MANUAL

SAFETY AGAINST FAILURE/EMERGENCY OPERATION

Defective component	Defect/Effect	Backup value/ Spare sensor	Possible to start engine?	Possible to run vehicle?
Fuel pump	Total failure: will not start	no	no	no
	Lack of pressure: power loss	no	yes	limited
Pressure regulator	same as fuel pump	no	see above	see above
Injection valve	Electric error	no	no	no
Coolant temperature sensor	poor cold start/engine operation	80°C	yes	limited
Air temperature sensor	Hardly any restriction	25°C	yes	limited
Manifold air pressure sensor	Emergency operation program	Throttle valve position	yes	limited
Ambient air pressure sensor	Hardly any restriction	97 kPa	yes	limited
Throttle valve sensor	Emergency operation program	Manifold air pressure sensor	yes	limited
Sensor for 2nd throttle valve	Emergency operation program	Closed	yes	limited
Pulse generator	No signal	no	no	no
Lambda probes	No lambda control	not necessary	yes	limited
Catalytic converter	No conversion	no	yes	yes
	Clogged: lack of power	no	limited	limited
Idle speed control motor	No idle control	no	limited	limited
Stepper motor for 2nd throttle valve	Throttle valve can easily be moved	no	yes	limited
Ignition coil	Misfire	no	limited	limited
	Short circuit/interruption	no	no	no
Fuel pump relay	Not functioning	no	no	no
Main relay	Not functioning	no	no	no
Secondary air valve	No lambda control	no	yes	limited
Roll angle sensor	Engine does not switch off during crash	no	yes	yes

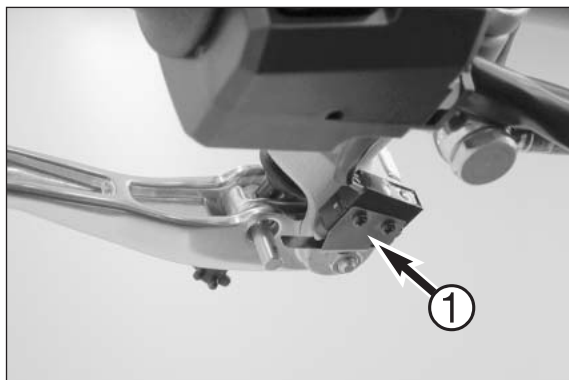

Clutch switch (input)

The clutch switch ① status can be scanned with the KTM diagnostics tool.

NOTE: the clutch switch delivers a ground signal to the ECU when actuated, this function is especially important for the idle speed control.

- Ground supply (brown cable) at connector AL1.
- Check the wiring from connector AL1 to connector AO for continuity.

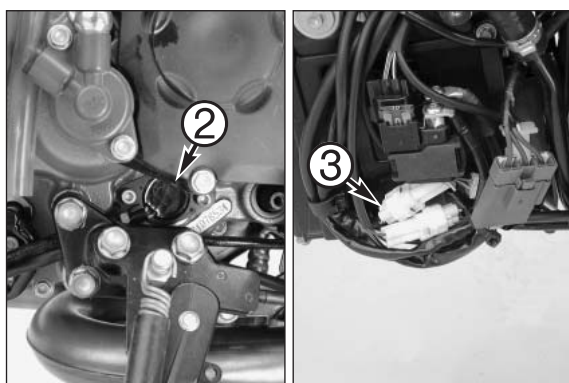
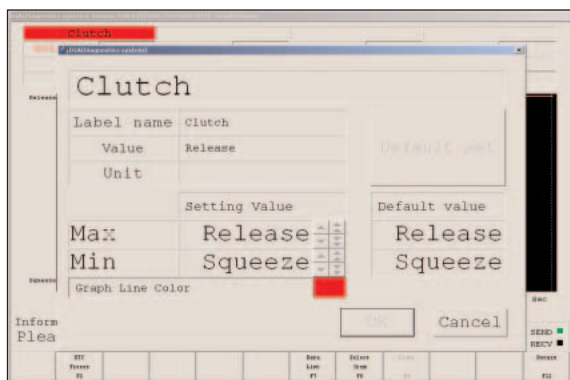

Gear sensor (neutral, 2, 3) (input)

The current status of the gear sensor ② can be scanned with the KTM diagnostics tool.

Respective gear engaged: max. 3.31 volts
Respective gear not engaged: min. 4.14 volts

In case of an error, perform the following tests:

- Check the wiring from connector AM2 ③ to connector AO for continuity.

NOTE: This function is especially important for the idle speed control.

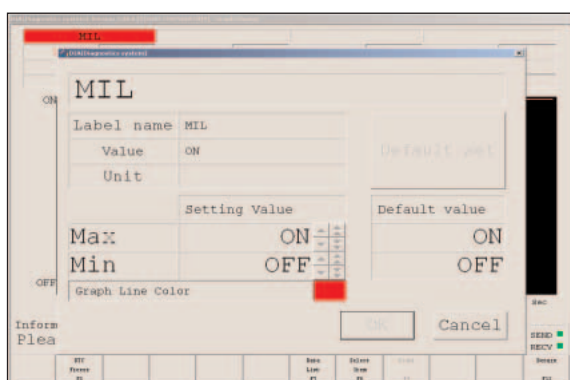
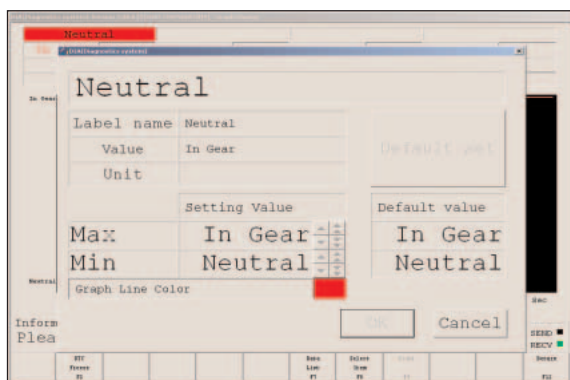

Error lamp (output)

The error lamp (FI) can be tested with the KTM diagnostics tool.

NOTE: the error lamp must light up for 2 seconds and then go out after the ignition is switched on if no ignition error is detected by the ECU.

If the error lamp does not switch on, perform the following tests:

- There must be positive output voltage at connector CO Pin 16 (with the ignition on, white cable).
- Check the wiring from connector CO to connector AA Pin 8 for continuity.

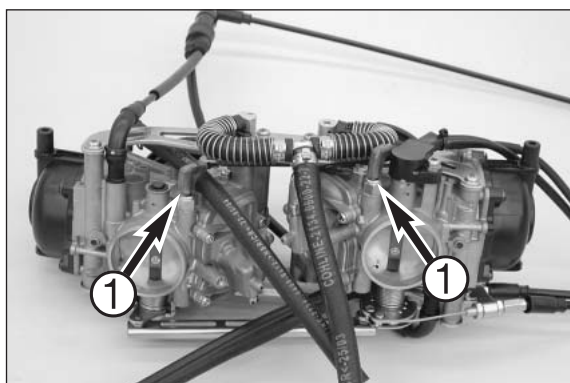

Carburetor heater

- Pull the wiring harness connectors ① from the carburetor heater elements.

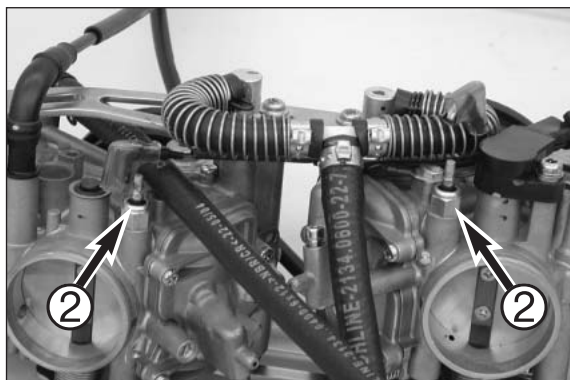

- Unscrew the carburetor heater elements ②.

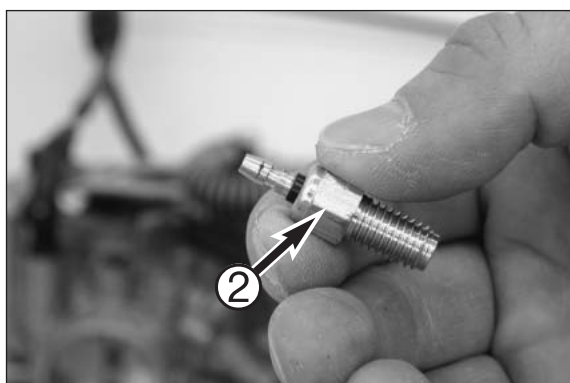

- Check the carburetor heater elements ② for damage at the connectors, check the electrical resistance (see Chapter 7).

- Tightening torque for the carburetor heater elements: 4 Nm

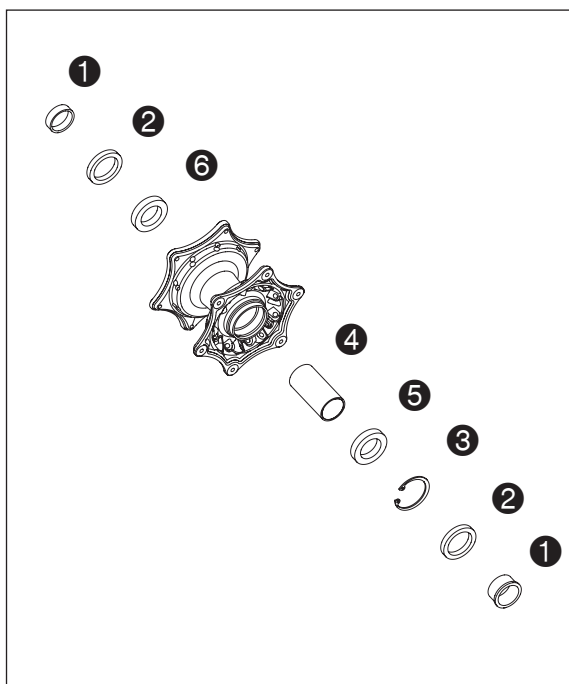

Replacing the front wheel bearing

- To dismount the front wheel, see page 10-2.
- Pull out both distance bushings **1**, pry both shaft seal rings **2** out of the hub and take the lock ring **3** out of the hub with suitable pliers.
- Push the bearing spacing tube **4** aside and knock the grooved ball bearing **5** out from the opposite side with a driver.
- Take the bearing spacing tube out of the hub and knock out the second grooved ball bearing **6**.
- Press a new grooved ball bearing **6** into the hub with a suitable tool.

! CAUTION !

WHEN YOU PRESS IN THE BEARING, MAKE SURE TO PRESS THE OUTER RING ONLY. IF YOU PRESS THE INNER RING, THE BALLS OR THE BEARING SURFACES OF THE BALLS WILL BE DAMAGED.

- Insert the bearing spacing tube in the hub and press in the grooved ball bearing **5**, again making sure that you only press the outer bearing ring.
- Mount the lock ring **3**, grease the new shaft seal rings **2** and press in with the back of 584.29.091.000 until flush.
- Attach both distance bushings **1**.

NOTE: the collared bushing must be mounted on the left.

- To remount the front wheel, see page 10-2.

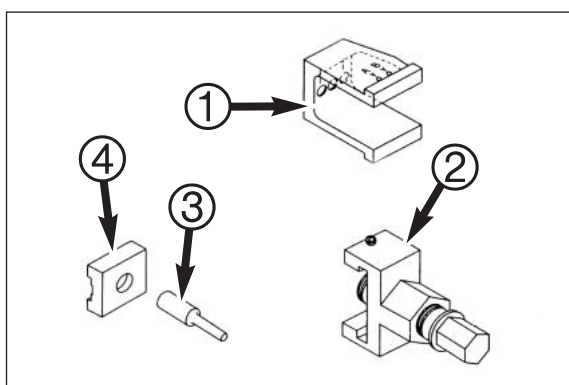

Opening the chain with a separating/rivet tool

NOTE: an X-ring chain, type 525 HV (5/8 x 5/16"), is used for the KTM 950 Adventure and 990 Super Duke models. You will need special tool 600.29.020.000 to separate or rivet the chain according to the manufacturer's specifications. This special tool consists of a bracket 1 with 2 marks (A and B), a pressing tool 2 with spindle and a locking screw, pressing pin 3 and the end plate 4.

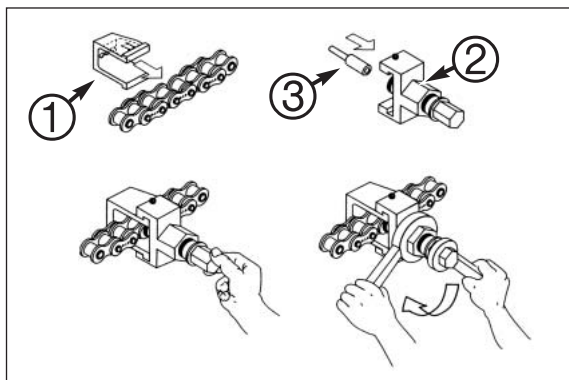

- Place bracket 1 over the chain from behind. The marks (A, B) should face up.
- Insert pressing pin 3 with the larger diameter into the spindle of pressing tool 2 and turn spindle back.
- Apply pressing tool 2 with pressing pin 3 to a chain link, the locking screw must face up.
- Slide bracket 1 into pressing tool 2 from the side, positioning the bracket in such a way that the arrow on mark A points to the locking screw.
- Screw in the locking screw to fix bracket 1 in position A.
- Holding pressing tool 2 with a ring wrench (wrench size 27 mm), screw in the spindle of the pressing tool and press out the chain through the hole in the bracket.

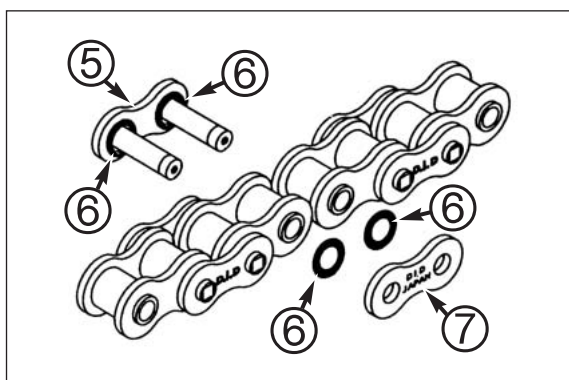

Riveting the chain

- Grease the connecting link 5, slide an X-ring 6 on each bolt and connect the ends of the chain.
- Fasten another X-ring 6 to each bolt.

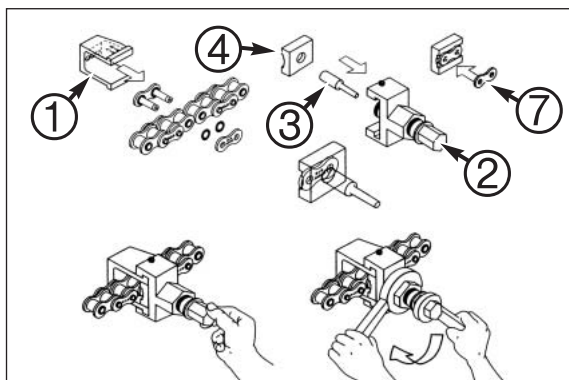

- Place bracket 1 over the chain from behind. The marks (A, B) must face up.
- Slide pressing pin 3 with the smaller diameter into the spindle of pressing tool 2 and turn spindle back.
- Insert the chain joint shim 7 in the end plate 4 and slide both into the pressing tool.
- Apply pressing tool 2 with end plate 4 and the chain joint shim 7 to the connecting link 5 in such a way that the locking screw faces up; the hole on the back of the end plate will accommodate pressing pin 3.
- Slide bracket 1 into pressing tool 2 from the side, positioning the bracket in such a way that the arrow on mark A points to the locking screw.
- Screw in the locking screw to fix bracket 1 in position A.
- Holding pressing tool 2 with a ring wrench (wrench size 27 mm), screw in the spindle of the pressing tool and press on the chain joint shim 7.

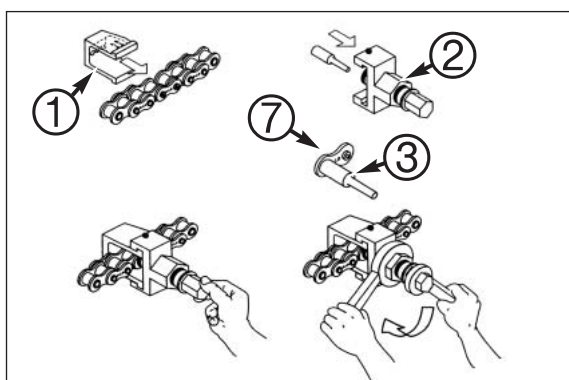

- Loosen the locking screw, remove pressing tool 2 and end plate 4.
- Apply pressing tool 2 to the chain again without end plate 4. The bracket 1 must be mounted in such a way that the arrow on mark B points to the locking screw.
- Screw in the locking screw to fix bracket 1 in position B.
- Holding pressing tool 2 with a ring wrench (wrench size 27 mm), screw in the spindle of the pressing tool and press both bolts of the connecting links together.
- Completely remove the separating/riveting tool.

TOLERANCES AND FITTING CLEARANCES

COMPONENT	MEASUREMENT/TEST	SETPOINT VALUE	TOLERANCE LIMIT
Valves	Valve shaft runout		.max. 0.1mm
	Sealing seat width, intake	1.2 mm – 1.8 mm	
	Sealing seat width, exhaust	1.5 mm – 2.0 mm	
	Valve disk runout		.max. 0.03 mm
	Valve guide, inner diameter	6.006 mm – 6.018 mm	.max. 6.05 mm
	Valve shaft, outer diameter, intake	5.967 mm – 5.980 mm	
Valve shaft, outer diameter, exhaust	5.973 mm – 5.987 mm		
Valve springs 950 Adventure	Inner length, unloaded	.new 39.4 mm	.min. 38.0 mm
	Outer length, unloaded	.new 42.8 mm	.min. 41.3 mm
Valve springs 990 Super Duke	Inner length, unloaded	.new 37.8 mm	.min. 37.0 mm
	Outer length, unloaded	.new 42.0 mm	.min. 41.2 mm
Camshafts/cylinder head 950 Adventure	Cam height, intake	37.80 mm – 37.90 mm	
	Cam height, exhaust	36.45 mm – 36.55 mm	
Camshafts/cylinder head 990 Super Duke	Cam height, intake	38.75 mm – 38.85 mm	
	Cam height, exhaust	38.15 mm – 38.25 mm	
	Camshaft bearing bore	24.000 mm – 24.021 mm	
	Camshaft bearing journal	23.960 mm – 23.980 mm	
	Camshaft bearing clearance	0.020 mm – 0.061 mm	.max. 0.09 mm
	Cylinder head distortion		.max. 0.05 mm
Cylinder 950 Adventure	Size I	100.000 mm – 100.012 mm	
	Size II	100.013 mm – 100.025 mm	
	Cylinder distortion		.max. 0.05 mm
Cylinder 990 Super Duke	Size I	101.000 mm – 101.012 mm	
	Size II	101.012 mm – 101.025 mm	
	Cylinder distortion		.max. 0.05 mm
Piston 950 Adventure	Size I – 9 mm (from lower edge)	99.953 mm – 99.967 mm	
	Size II – 9 mm (from lower edge)	99.963 mm – 99.977 mm	. . . 99.930 mm
	Mounting clearance	0.04 mm – 0.06 mm 0.10 mm
Piston 990 Super Duke	Size I – 9 mm (from lower edge)	100.943 mm – 100.957 mm	
	Size II – 9 mm (from lower edge)	100.953 mm – 100.967 mm	. . 100.930 mm
	Mounting clearance	0.05 mm – 0.07 mm 0.10 mm
Piston ring 950 Adventure	Gap	0.15 mm – 0.35 mm 0.5 mm
	Width of piston ring groove – 1st ring (L-ring)	0.92 mm – 0.94 mm	
	Width of piston ring groove – 1st ring (L-ring)	1.80 mm – 1.84 mm	
	Width of piston ring groove – 2nd ring	1.27 mm – 1.29 mm	
	Width of piston ring groove – oil scraper ring	2.51 mm – 2.53 mm	
	Thickness of 1st ring (L-ring)	0.85 mm – 0.87 mm	
	Thickness of 1st ring (L-ring)	1.20 mm – 1.22 mm	
	Thickness of 2nd ring	1.22 mm – 1.24 mm	
Piston ring 990 Super Duke	Gap	0.15 mm – 0.35 mm 0.5 mm
	Width of piston ring groove – 1st ring (L-ring)	0.92 mm – 0.94 mm	
	Width of piston ring groove – 1st ring (L-ring)	1.80 mm – 1.84 mm	
	Width of piston ring groove – 2nd ring	1.25 mm – 1.29 mm	
	Width of piston ring groove – oil scraper ring	2.50 mm – 2.53 mm	
	Thickness of 1st ring (L-ring)	0.85 mm – 0.88 mm	
	Thickness of 1st ring (L-ring)	1.20 mm – 1.27 mm	
	Thickness of 2nd ring	1.22 mm – 1.24 mm	
Piston pin / piston	Diameter of piston ring bore	22.006 mm – 22.011 mm	. . . 22.030 mm
	Diameter of piston pin	21.996 mm – 22.000 mm	. . . 21.980 mm

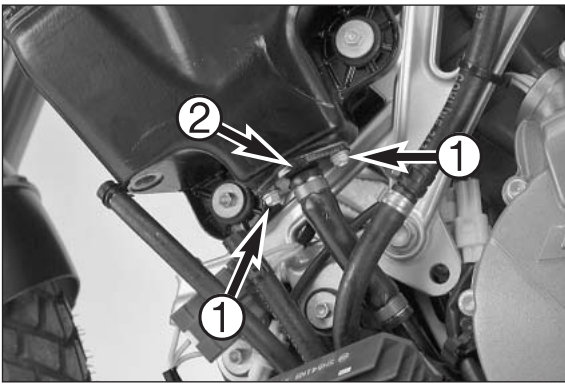

- Remove both bolts ❶ from the oil tank connection ❷ and tilt the oil tank aside together with the oil return valve.
- Remove the screen and cleanse.

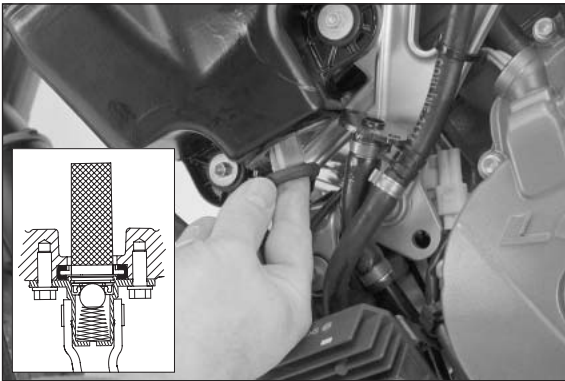

- Grease the seal ring and carefully slide the oil screen into the oil tank. Position the oil tank connection together with the oil return valve, mount the bolts and tighten to 10 Nm.

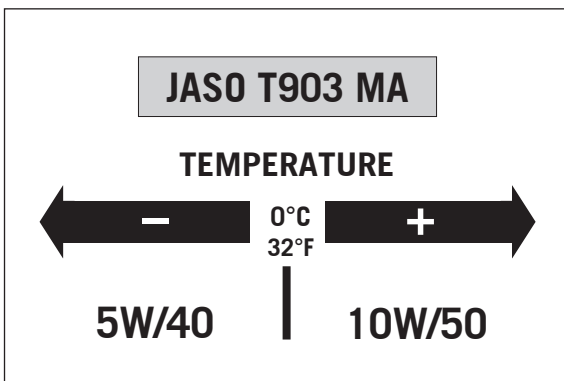

Engine oil

Automobile engine oil used to be used for four-stroke motorcycles before there were separate motorcycle specifications. Different technical developments made it necessary to have a separate specification for four-stroke motorcycles - the JASO T903 MA standard. Whereas car engines require long changing intervals, motorcycle engines require a higher power output at higher speeds. Most motorcycle engines also use the same oil to lubricate the transmission and the clutch. The JASO MA standard responds to these special requirements.

Only use fully synthetic engine oils that meet the JASO MA quality requirements (see information on the can). KTM recommends Motorex Power Synt 4T in the 10W/50 viscosity (for temperatures over 0°C) or 5W/40 (for temperatures under 0°C).

- Fill approx. 2.7 liters of engine oil into the oil tank. The oil tank will be filled up to the top.
- Start the engine and allow to idle for about one minute without accelerating.
- Switch off the engine and pour another 0.3 liters into the oil tank. Check the oil system for leakage.

! CAUTION !

DO NOT REV UP THE ENGINE RIGHT AFTER CHANGING THE OIL SINCE ALL OF THE LUBRICATING POINTS WILL NOT BE SUPPLIED WITH ENOUGH OIL YET.

Checking the engine oil level

Check the engine oil level when the engine is warm (at least 4 bars on the temperature indicator will light up). Place the motorcycle on a level surface (not on the side stand).

Turn off the engine, unscrew the oil dipstick ❸ and wipe off with a cloth. Screw the oil dipstick **all the way back in** and back out again. The oil level should fall between the lower end of the oil dipstick (MIN) and the MAX mark.

The oil capacity between the MIN and MAX mark is 0.5 liters. For engines with an inspection pipe, the oil level should be between the MIN and MAX marks. Add more engine oil if necessary and check the engine for leakage.

- ! CAUTION !**
- NOT ENOUGH ENGINE OIL OR LOW-QUALITY OIL WILL LEAD TO PREMATURE ENGINE WEAR.
 - DO NOT EXCEED THE MAXIMUM LEVEL.
 - DO NOT ALLOW TO FALL BELOW THE MINIMUM LEVEL.

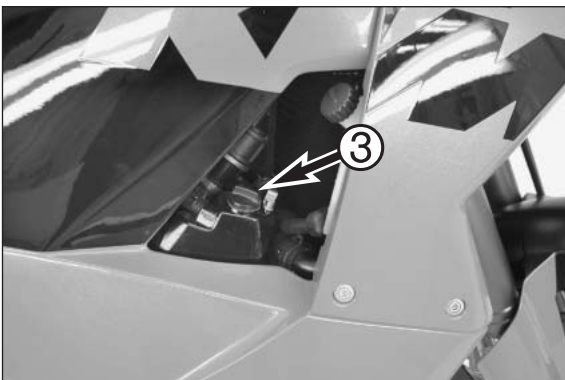

LUBRICATION AND MAINTENANCE WORK – ADDITIONAL WORK**Completely servicing the fork**

- Dismounting the fork legs: see Chapter 10
- Maintenance: see WP-documentation

Completely servicing the shock absorber

- Dismounting the shock absorber: see Chapter 10
- Maintenance: see WP-documentation

Cleaning and greasing the steering head bearing and sealing elements

- Jack up the motorcycle until the front wheel no longer touches the ground.
- Loosen the 5 clamp bolts on the upper triple clamp and remove the blind nut on the steering stem.
- Move the upper triple clamp upwards but do not pull the triple clamp all the way off of the steering stem ❶. The weight of the front wheel and the fork will give you access to the lower steering head bearing.

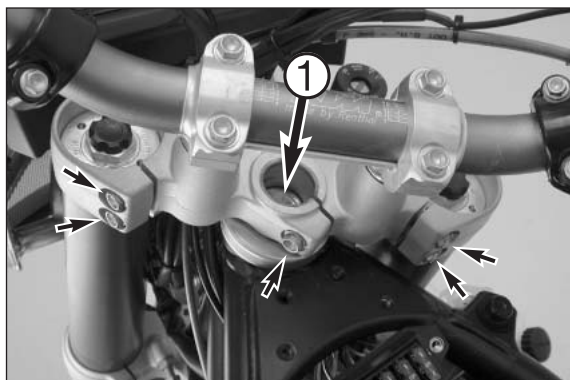

- Clean the gasket element ❷ and grease the lower steering head bearing ❸.

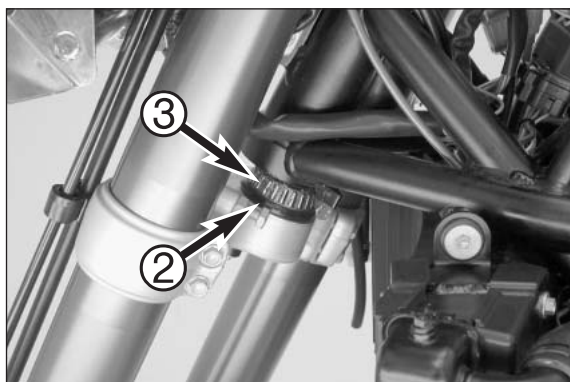

- Lift the front wheel to have access to the upper steering head bearing. Clean the gasket element, raise the protection ring ❹ and grease the upper steering head bearing ❺.

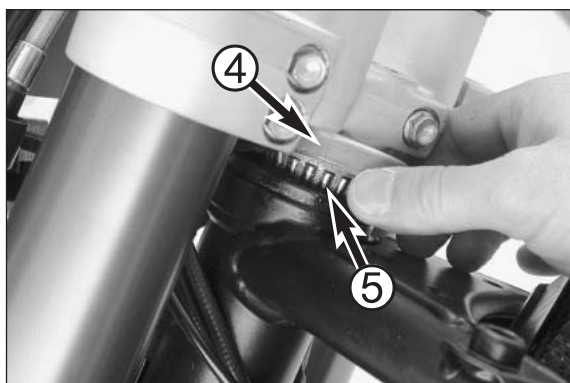

- Place the front wheel on the ground, press the upper triple clamp down, screw the blind nut back in until the bearings have no clearance.

NOTE: do not tighten the blind nut since you may damage the bearing.

- Gently tap on the upper triple clamp with a plastic hammer to relieve any distortion and tighten the 5 clamp bolts on the top triple clamp to 20 Nm.

ignition switch

	r-w	r-w	r-w	o	y-r	r
ON	●	●	●	●	●	●
OFF						
LOCKED						

start switch

cable harness	or	bl-or
cable switch		bl-bu bl
START	●	●
unpushed		

kill switch

cable harness	re	or
cable switch	or	bl-wh
RUN	●	●
STOP		

sidestand switch

cable harness	br	pi	
cable switch	gn	bl	br
folded up	●	●	
folded down			



clutch switch

switch position	ye	br
pulled	●	●
unpulled		



ignition switch

	r-w	r-w	r-w	o	y-r	r
ON 	●	●	●	●	●	●
OFF						
LOCKED						

light switch

cable harness	ye-br	wh	ye
cable switch	ye-wh	wh	re-ye
LIGHT OFF			
P. LIGHT 		●	●
LIGHT 	●	●	●

high/low beam switch

cable harness	bu	gn	ye-br
cable switch	wh	ye	gn-re
LO 		●	●
HI 	●	●	●

brake switch

cable harness	gn-wh	ye-bu
cable switch	bl	bl
pushed	●	●
unpushed		

passing light

cable harness	ye	bu
cable switch	gn-bl	wh
P. HORN 	●	●
OFF		

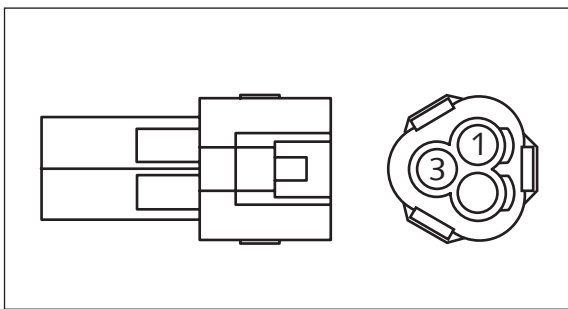

Connector AR
3-pole ❶

Speed sensor
Behind the headlight
under the connector
support

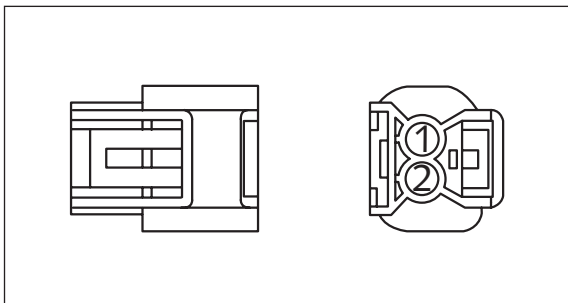
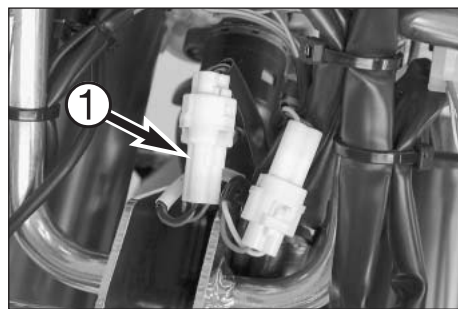

Connector AS
2-pole ❷

Rear ignition coil
Behind the air filter box

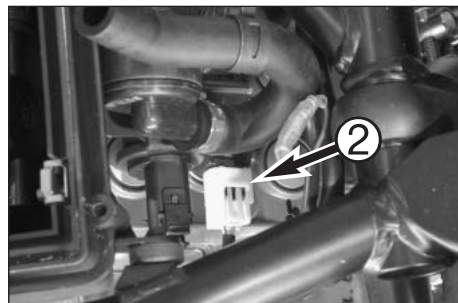

Connector AS1
2-pole ❸

Front ignition coil
Behind the radiator

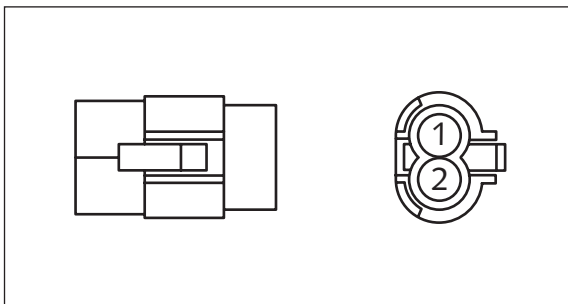
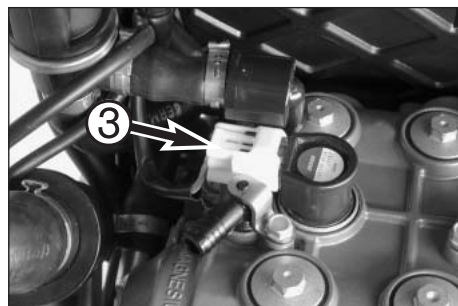

Connector AT
2-pole ❹

Pick up
Between the water pipe
and the front cylinder
head

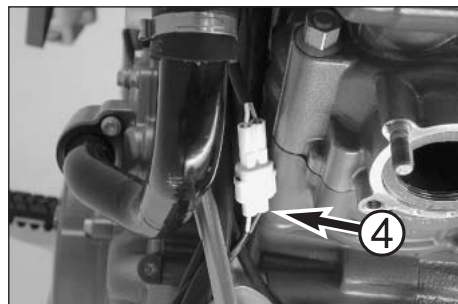

Connector AT1
2-pole ❺

Fuel sender
Between the left tank
and the frame



Connector AT2
2-pole ❻

Clutch switch
Behind the headlight
under the connector
support

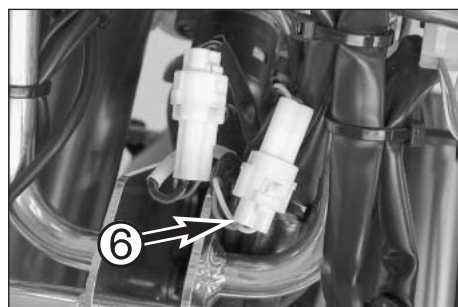

ignition switch

	r-w	r-w	r-w	o	y-r	r
ON 	●	●	●	●	●	●
OFF						
LOCKED						

start switch

cable harness	or	bl-or
cable switch	bl-bu	bl
START 	●	●
unpushed		

stop switch

cable harness	or -bl	or
cable switch	bl	bl -bu
RUN 	●	●
STOP		

clutch switch

switch position	ye	br
pulled	●	●
unpulled		

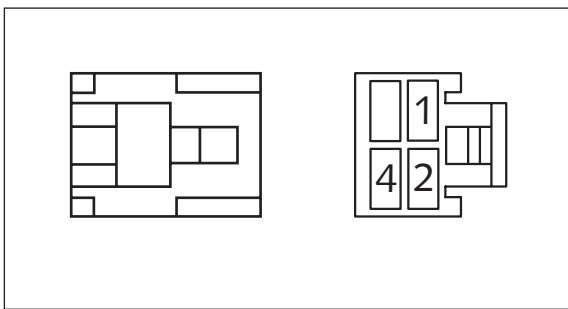

Connector AF
4-pole

Main relay ①
Under the seat

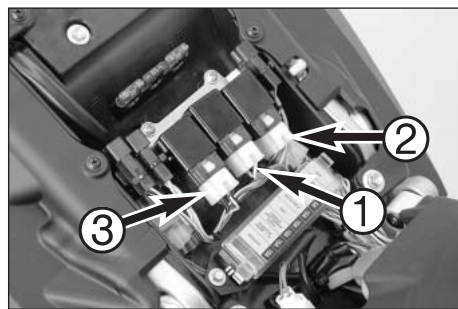

Connector AF1
4-pole

Fuel pump relay ②
Under the seat

Connector AF2
4-pole

Auxiliary starter relay ③
Under the seat

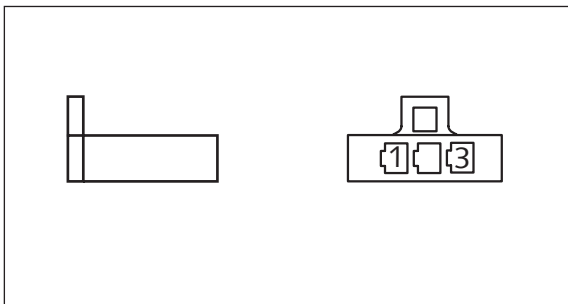

Connector AG
3-pole

Speedometer ④
Behind the headlight mask

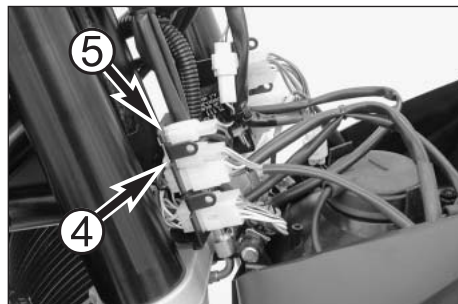

Connector AH
2-pole

Front brake light switch ⑤
Behind the headlight mask

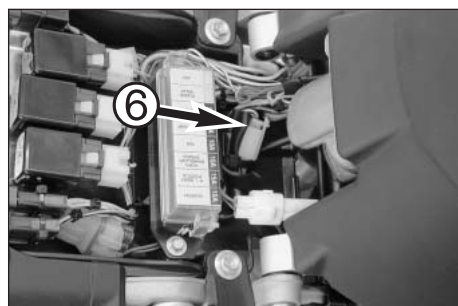

Connector AH1

Rear brake light switch ⑥
In front of the fuse box

Connector AH2

Turn signal relay ⑦
Behind the headlight mask

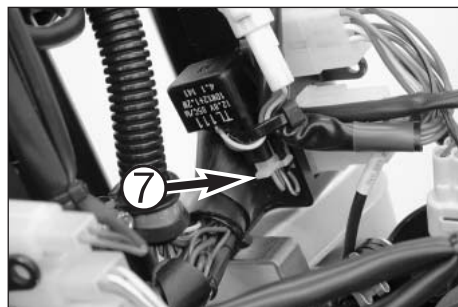

CLICK HERE TO **DOWNLOAD** THE COMPLETE MANUAL

- Thank you very much for reading the preview of the manual.
- You can download the complete manual from: www.heydownloads.com by clicking the link below



- Please note: If there is no response to CLICKING the link, please download this PDF first and then click on it.

CLICK HERE TO **DOWNLOAD** THE COMPLETE MANUAL