

**KOBELCO**

**OPERATOR'S MANUAL**  
**HYDRAULIC EXCAVATOR**  
**SK35SR-3**

SK35SR-3 PX12-11001~

Issued 07-2004

S2PX00009ZE-01 NA

CLICK HERE TO **DOWNLOAD** THE COMPLETE MANUAL

- Thank you very much for reading the preview of the manual.
- You can download the complete manual from: [www.heydownloads.com](http://www.heydownloads.com) by clicking the link below



- Please note: If there is no response to CLICKING the link, please download this PDF first and then click on it.

CLICK HERE TO **DOWNLOAD** THE COMPLETE MANUAL

**1. SAFETY PRECAUTIONS**

---

# 1. SAFETY PRECAUTIONS

## 1.4 SAFETY DURING OPERATION

### PASSENGERS

This equipment is not intended or designed for the transportation of persons. Never allow persons to ride on the machine. Serious injury or death can result from allowing passengers on or in the machine.

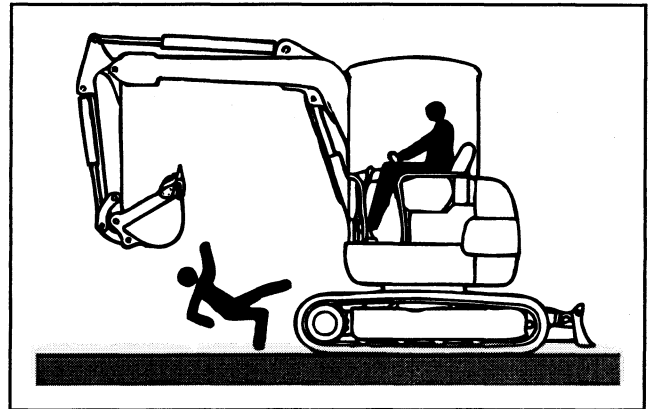

**NO PASSENGERS**

### STARTING ENGINE

Start engine from the operator's seat. Do not short circuit the starter circuit or battery to start the engine. This may cause serious injury or cause damage to the electrical system.

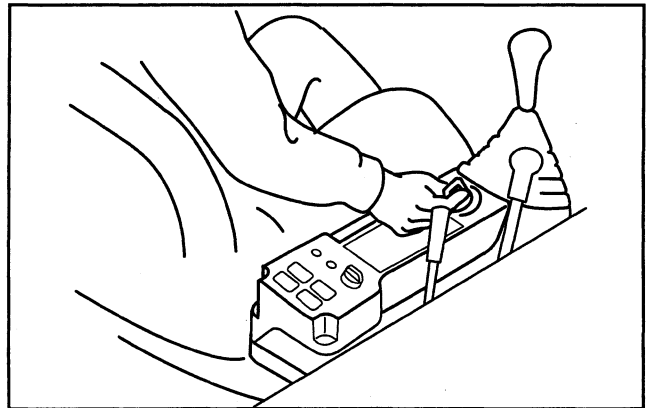

**DO NOT SHORT CIRCUIT**

### HORN BEFORE STARTING ENGINE

Sound the horn before starting the engine to alert people the machine is being started. Make sure no one is near the machine.

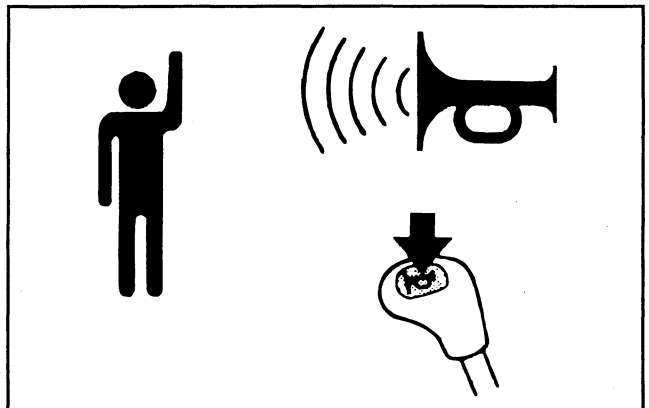

**SOUND HORN BEFORE STARTING**

### **CAUTION**

Do not start the engine if the "DO NOT OPERATE" tag has been tagged out.

### CHECK AFTER STARTING ENGINE

Make sure to check machine for proper functioning after starting the engine. Slowly cycle attachments, swing, and travel functions in an area with sufficient space, without obstacles, and personnel. Failure to do so could result in injury or machine damage. Make note of any abnormalities and repair as needed.

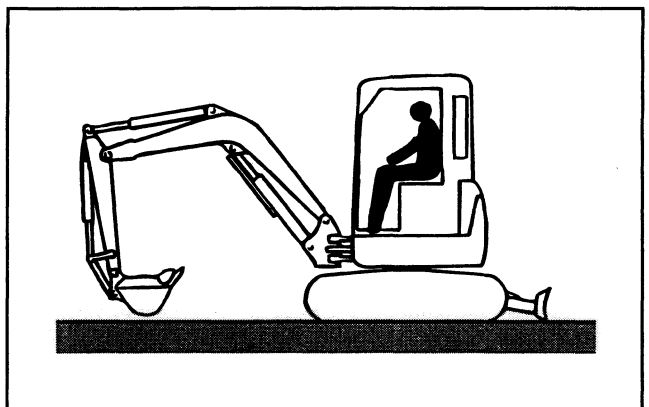

**CHECK AFTER STARTING ENGINE**

# 1. SAFETY PRECAUTIONS

## REFUELING

Move the machine to a well ventilated area for refueling. Use only specified fuel as described in the MAINTENANCE section of this MANUAL.

Immediately clean up all spilled fuel and dispose of waste properly. After refueling is complete, securely tighten fuel cap.

Never use the fuel for cleaning.

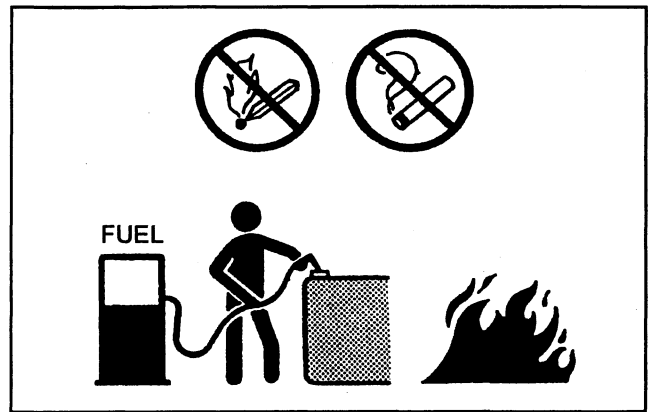

REFUELING

## SUPPORT THE MACHINE

If it becomes necessary to raise the machine for inspection or maintenance, always support the machine by positioning the machine as shown in the illustration and use safety supports (1) or blocks (2), with a sufficient capacity rating to support the machine, under the crawler/frame. **NEVER INSPECT OR PERFORM MAINTENANCE PROCEDURES UNDER A RAISED MACHINE THAT IS NOT SUFFICIENTLY SUPPORTED.**

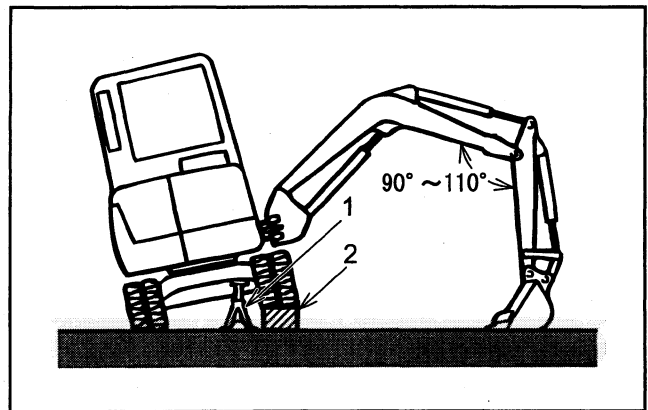

SUPPORT THE MACHINE

## HYDRAULIC PRESSURE

Under normal conditions, all circuits of the hydraulic system are under extreme pressure.

When inspecting for leaks, use a small piece of cardboard, wood or metal to locate leaks. **SMALL (PIN-HOLE) LEAKS CAN BE DANGEROUS IF CONTACT WITH SKIN OR EYES IS MADE.**

Wear approved safety glasses or face shield, gloves, hard hat, safety shoes and work clothes during all inspection and maintenance procedures. Seek for immediate medical assistance if injury occurs.

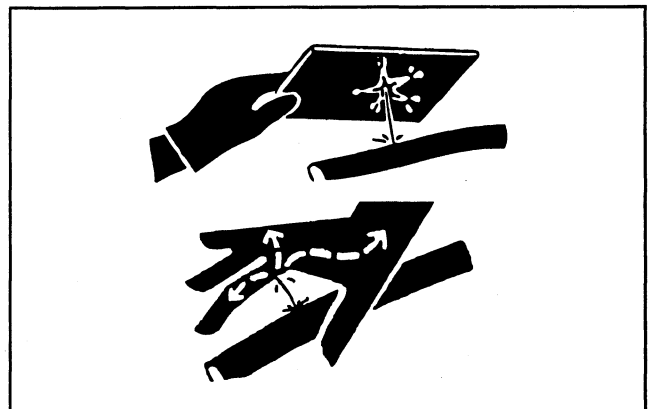

CHECKING FOR HIGH PRESSURE LEAKS

## PRESSURIZED FLUIDS & LUBRICANTS

Always release pressure from hydraulic reservoir, engine coolant, fuel system and all systems containing pressure before removing any caps or components. **BE CAUTIOUS OF HOT FLUIDS AND GASSES FROM SYSTEMS ON MACHINES THAT HAVE JUST BEEN STOPPED. ALLOW SUFFICIENT TIME FOR SYSTEMS TO COOL BEFORE PERFORMING ANY INSPECTION OR MAINTENANCE PROCEDURES.**



RELEASE HYDRAULIC TANK PRESSURE

# 1. SAFETY PRECAUTIONS

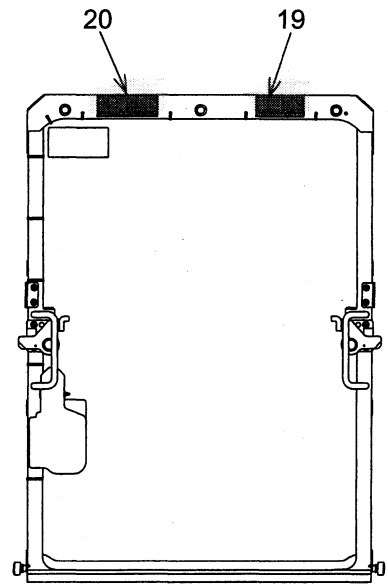
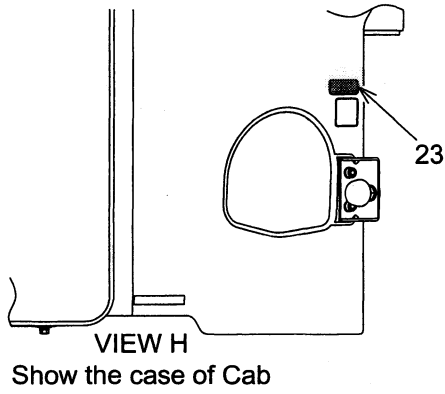
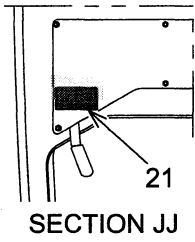

SHOW THE INSIDE OF FRONT WINDOW

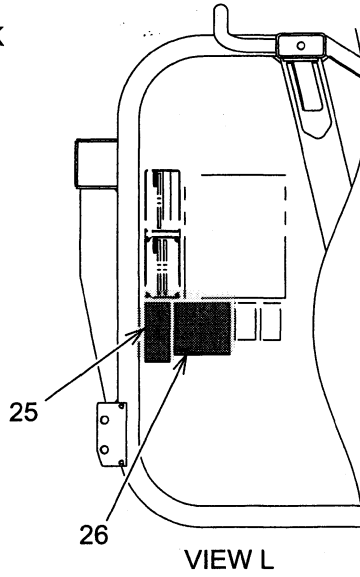
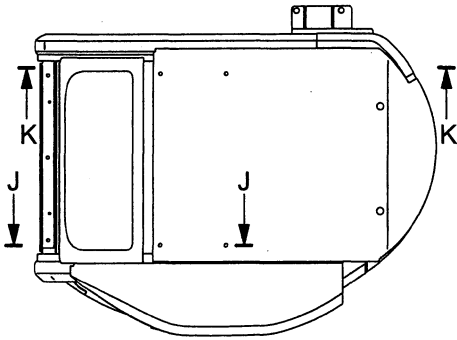

VIEW L

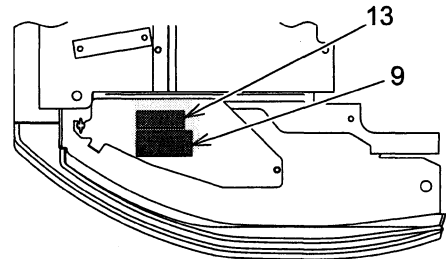

SECTION DD  
(CAB SPEC.)

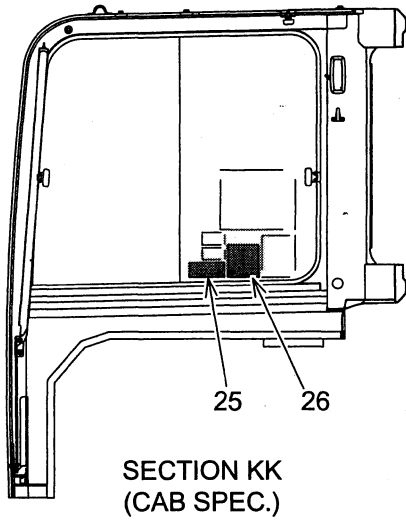

SECTION KK  
(CAB SPEC.)

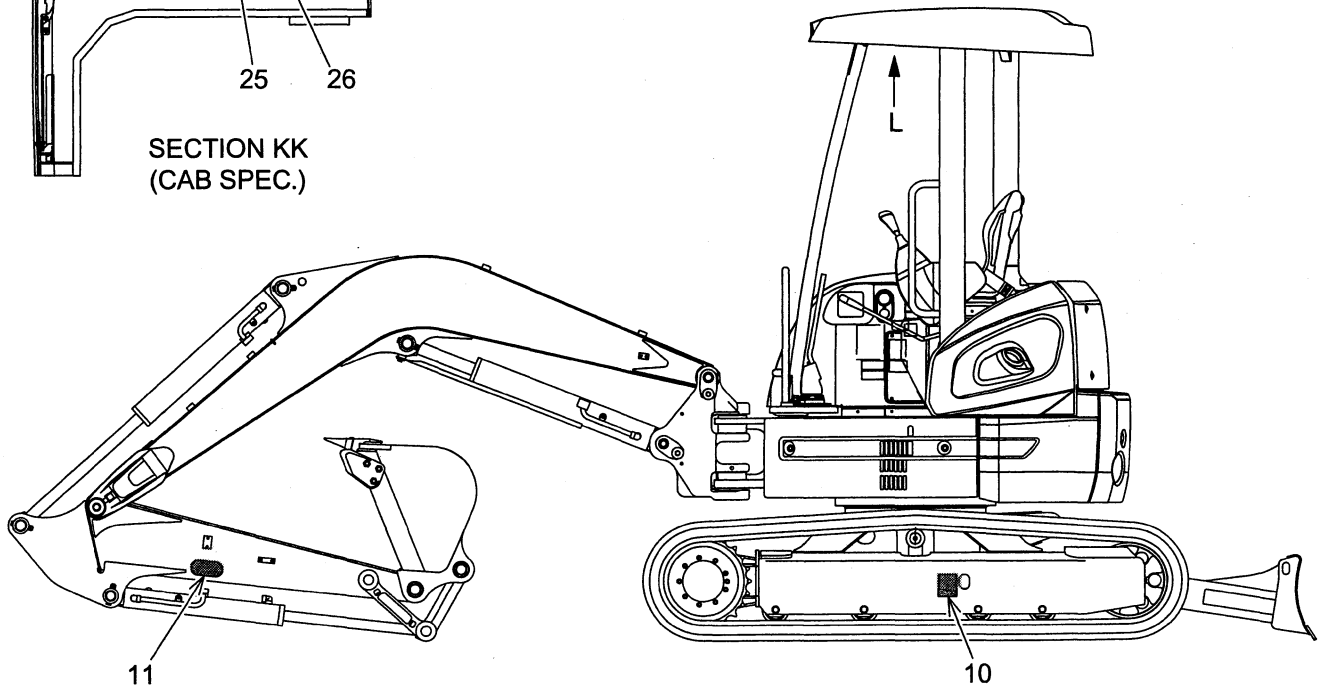

## 1. SAFETY PRECAUTIONS

### 1.9 END OF WORK SHIFT SAFETY

Perform all of the following procedures after each shift is complete to insure the machine is in optimal operating condition for the next shift or job site.

- a. Move the machine to a firm, level surface.
- b. Lower attachment to the ground.
- c. Refill fuel tank to full mark to reduce air volume and condensation (moisture). This will decrease the possibility of freezing in the fuel tank, rusting due to moisture and other problems associated with start up and operation.
- d. Close and secure all windows in place to prevent water or moisture reaching the electrical components of the machine (CAB only).
- e. Thoroughly clean and inspect the machine. Perform lubrication maintenance and repair or replace any problem areas found before restarting the machine.
- f. If performing the machine storage in cold climates, it may be necessary to remove the batteries from the machine and store in a warm well ventilated area. Install the batteries in the machine before next start up. This will help prevent premature battery deterioration.
- g. Remove key from key switch and lock all doors and access panels.

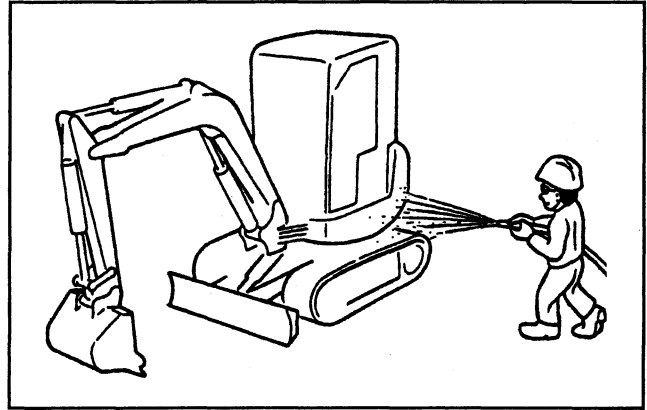

**END OF WORK SHIFT SAFETY**

## 2. MACHINE FAMILIARIZATION

---

1. If the engine is overheating, stop operation immediately and let the engine run at idling to lower the engine temperature.
2. Once the coolant has cooled down, stop the engine.
3. Once the engine temperature lowers, inspect the coolant level, fan belt, clogging of radiator core, etc. Refer to Chapter 4. **"MAINTENANCE"** for details.

---

### **⚠ WARNING**

**DO NOT PERFORM ANY KIND OF MAINTENANCE ON AN ENGINE THAT HAS JUST STOPPED WORKING. FLUIDS AND SURFACES WILL BE EXTREMELY HOT. ALLOW THE ENGINE TO COOL BEFORE PROCEEDING TO INSPECTION AND/OR MAINTENANCE.**

---

#### **5. BATTERY CHARGE LAMP (Red)**

This is to warn an abnormality in the battery charging system during engine running. This indicator will illuminate when the starter switch is turned to the "ON" position, and should turn off after the engine is started. Check the charging system if this indicator does not turn off after the engine is started. See Chapter 4. **"MAINTENANCE"** for details.

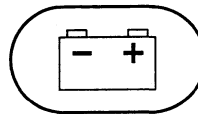

#### **6. LOW FUEL WARNING LAMP (Red)**

If the fuel is low, a warning lamp lights. Stop the engine immediately and add fuel.

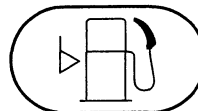

#### **7. AIR CLEANER CLOGGING LAMP (Red)**

This lamp comes on if the air cleaner filter is clogged. If the lamp comes on, clean or replace the element immediately.

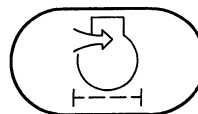

### **C. INDICATOR LAMP**

This lamp indicates the working conditions.

#### **8. HIGH (2ND) TRAVEL SPEED LAMP (Yellow)**

This indicator will be illuminated when the travel speed is switched to high (2nd.) speed. The travel speed selector switch is located on the grip of the right travel lever.



The speed automatically returns to low (1st.) speed when the starter switch is set to "OFF".

## 2. MACHINE FAMILIARIZATION

### 2.4.5 CAB (OPTION)

The following equipment are provided for the cab to ventilate or to facilitate operation.



**WHEN USING THE EQUIPMENT IN THE CAB, SET THE SAFETY LOCK LEVER TO THE LOCKED POSITION TO AVOID UNEXPECTED MACHINE MOVEMENT IF A WORK LEVER IS ACCIDENTALLY CONTACTED WHICH COULD CAUSE PERSONAL INJURY.**

#### A. LOCKING CAB DOOR

To lock the door in the open position, slide the door fully until locks on the catch located on the rear of the cab.

1. CATCH
2. HANDLE
3. KEY

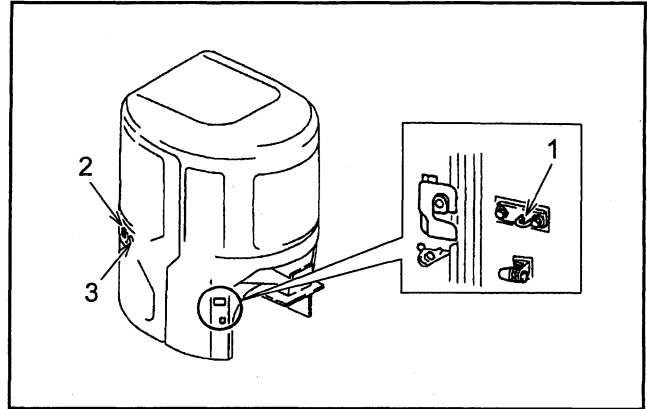

#### B. UNLOCKING DOOR FROM INSIDE

To unlock the door, pull the lever (1) backward.

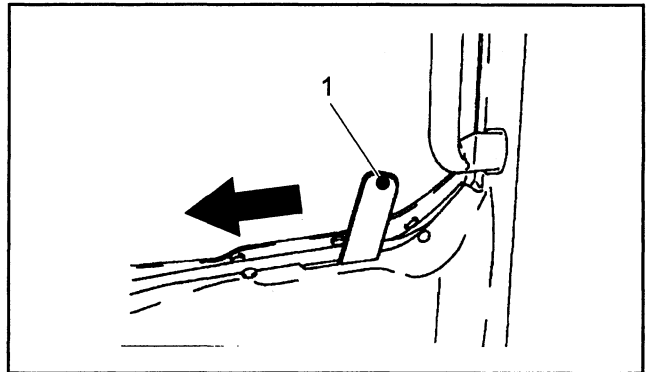

#### C. HOUSING (UPPER) FRONT WINDSHIELD

The upper front windshield is able to slide into ceiling for storage.



Ensure to move the machine to the level ground when opening/closing the front windshield, and lock it. Especially, unlocking windshield at forward-inclined posture of the machine causes falling down of front windshield.

1. Move the machine to the level ground, set the safety lock lever to lock position, then stop the engine.
2. Push down the lock levers (1) provided on the left/right sides to unlock the front windshield.
3. Grasp the handle provided on the left/right sides of front windshield, hold it up and slide into backside ceiling.

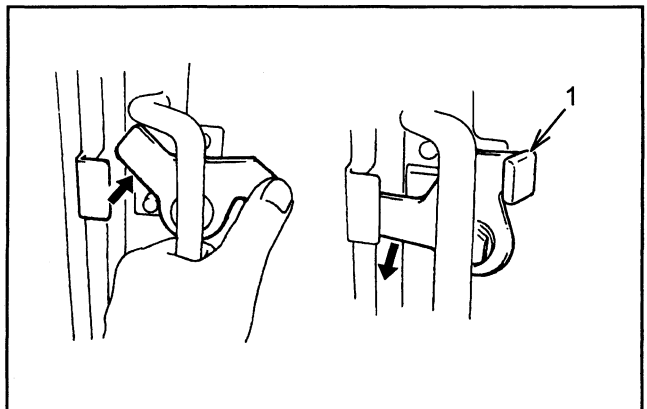

### 3. MACHINE OPERATION

#### 3.1.2 INSPECTION BEFORE OPERATION

The following items should be inspected before starting machine operation:

##### A. CHECK COOLANT LEVEL



**NEVER REMOVE RADIATOR CAP WHEN ENGINE IS HOT. ALLOW ENGINE TO COOL DOWN BEFORE REMOVING RADIATOR CAP.**

The radiator reservoir tank is provided on the right side of the engine compartment.

1. Check the coolant level with cold engine.
2. Open engine reservoir tank. The coolant level should be between the lines of FULL and LOW.

##### Note

Engine coolant level is higher than normal when the engine is warm. The coolant level will lower with engine temperature.

Maintain coolant level at the full mark with engine cold. Refer to 4-10 for engine coolant specifications.

3. Open radiator reservoir tank cap (1) to refill with proper coolant mixture.

Check the radiator coolant level when the coolant level in the reservoir tank drops below the LOW level mark. Make sure to check the engine cooling system for leakages and repair as needed, before resuming operation.

4. See 4-30 for reference. Remove the radiator cap (2), and check for proper coolant level.
5. Refill radiator with proper coolant mixture.
6. Install radiator cap (2) and tighten securely.



**BE CAUTIOUS OF HOT FLUIDS AND SURFACES. WEAR GOGGLES, SAFETY SHOES, HARD HAT, WORK CLOTHES, AND WORK GLOVES TO PERFORM INSPECTION AND MAINTENANCE ON THIS MACHINE.**

##### B. CHECK COOLANT LEAKAGE

If the coolant level in the radiator reservoir tank does not lower, but the coolant inside the radiator does, there is a possibility of air leakage in the cooling system. Make sure coolant level is to specifications and pressurize system to check for leakages. Consult with our distributor for advise and/or repairs. Make sure to repair leakages before resuming operation.

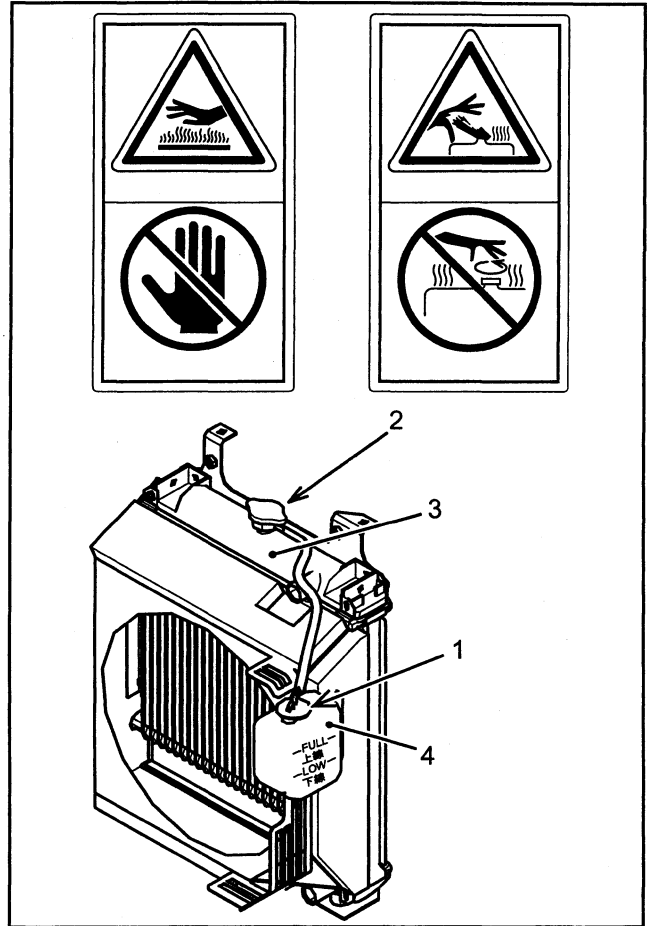

### 3. MACHINE OPERATION

#### 3.1.5 STOPPING MACHINE ENGINE

Make sure to idle the engine for at least 5 minutes before machine shut down.

#### **CAUTION**

When the machine is suddenly stopped while high speed operation of the engine, temperature of the engine is rapidly increased causing for deterioration of engine oil and seizure of seals.

1. Normally, place the attachment on the ground before stopping the engine (except for special situations).
2. Make sure to place the safety lock lever in the "LOCKED" (up) position before leaving the cab.
3. Push the throttle lever (1) all the way forward to low idle position for about 5 minutes.  
Operate the engine at idling for a while to lower the coolant temperature.
4. Turn the starter key (2) to OFF to stop the engine.
5. Remove the starter key (2).

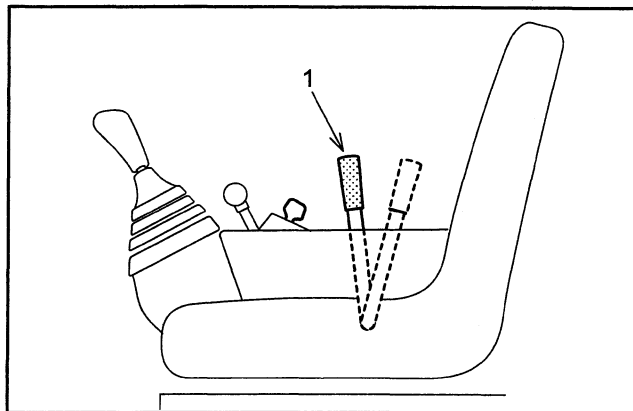

LOW IDLING POSITION

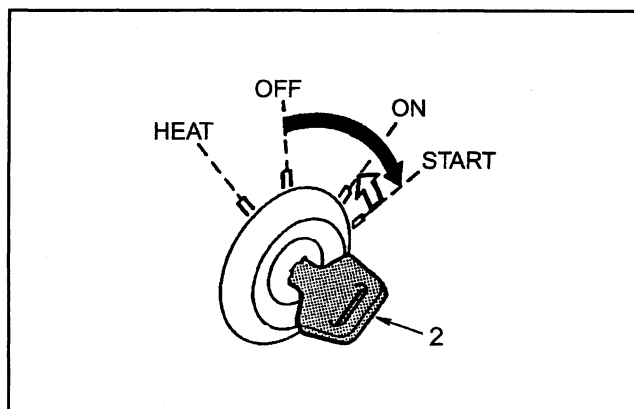

#### 3.1.6 INSPECTION AFTER STARTING MACHINE ENGINE

Check and ensure the following items after starting the engine.

#### **WARNING**

- CARELESS CONTACT WITH ANY OPERATING LEVER WILL CAUSE UNEXPECTED SUDDEN MACHINE MOVEMENT. STANDING OR SHIFT BODY POSITION OF THE OPERATOR AFTER SECURELY SETTING THE SAFETY LOCK LEVER AT "LOCKED" (UP) POSITION.
- MAKE CERTAIN THE SWING AREA OF MACHINE IS CLEAR OF PEOPLE AND OBSTACLES BEFORE OPERATING. KNOW THE POSITION OF THE TRAVEL MOTORS BEFORE STARTING TRAVELLING AND MAKE SURE TO SOUND HORN BEFORE STARTING OPERATION.

#### Note

- Do not apply any heavy load on to the new engine for the first 50 hours operation.
- Confirm the LIGHT-OFF for each warning lamp.
- Carefully listen to any abnormal sound.
- Check for leakages for oil and water around the engine.
- At the first engine start-up of the day, operate the engine for around 5 minutes with no load to warm up the engine and reach oil to every part of the engine.

### 3. MACHINE OPERATION

In case the machine is not able to travel because its crawler is stuck in mud, sand or gravel on the soft ground, take each crawler off the ground by pushing the boom and arm against the ground, scrape off mud, sand and gravel and then get the machine out of the trouble. Gravel and mud may be cleared if you rotate the raised crawler back and forth.

#### **CAUTION**

Operate the machine at the operator's seat. Do not allow any person to come near the machine.

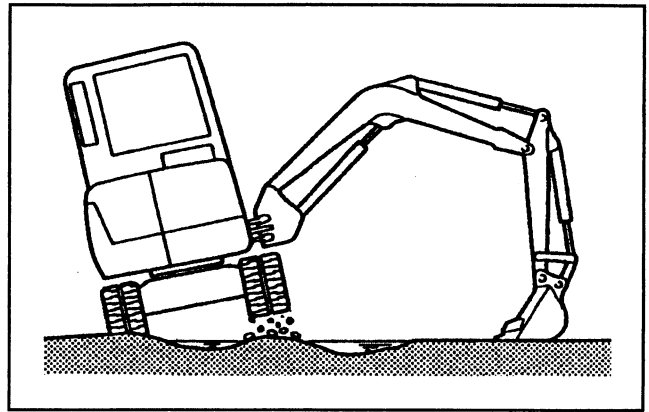

### G. SLEWING OPERATION

#### **WARNING**

- OPERATION OF THIS MACHINE ON AN INCLINE OR SLOPE MAY CAUSE THE MACHINE TO BECOME UNSTABLE OR UNBALANCED.
- MAKE CERTAIN THE SLEWING AREA OF THE MACHINE IS CLEAR OF PEOPLE AND OBSTACLES BEFORE SLEWING.
- WORK UP AND DOWN INCLINES OR SLOPES, NEVER ACROSS.
- NEVER SLEWING OR TURN MACHINE AROUND ON SLOPES.
- OPERATE CONTROL LEVERS CAREFULLY TO PREVENT SUDDEN MOVEMENTS WHICH MAY CAUSE THE MACHINE TO SLIDE OR TIP OVER.
- BUILD A LEVEL AREA FOR THE MACHINE TO OPERATE.
- USE A FLAGMAN TO GUIDE THE OPERATOR.

1. LEFT OPERATING LEVER
- A. SLEWING RIGHT
- B. SLEWING LEFT

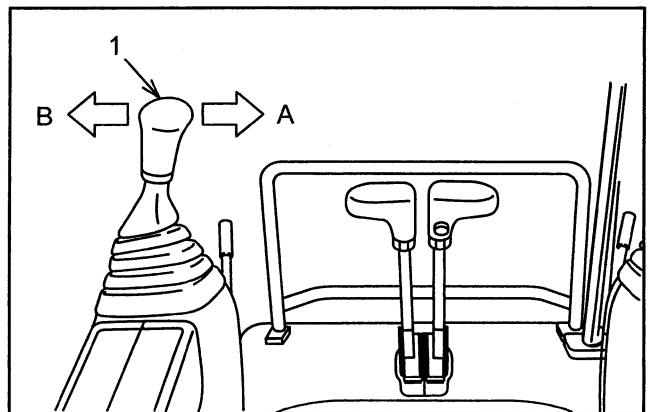
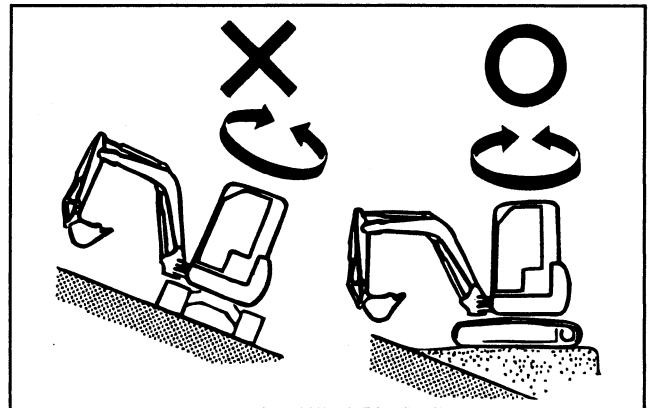

CLICK HERE TO **DOWNLOAD** THE COMPLETE MANUAL

- Thank you very much for reading the preview of the manual.
- You can download the complete manual from: [www.heydownloads.com](http://www.heydownloads.com) by clicking the link below



- Please note: If there is no response to CLICKING the link, please download this PDF first and then click on it.

CLICK HERE TO **DOWNLOAD** THE COMPLETE MANUAL

### 3. MACHINE OPERATION

10. Install cover (2) with snap ring (3).

#### Note

The sprocket for this crawler becomes free rotation from the travel motor.

11. Install drain plug (4) and refill unit with drained oil that stored in the container before.
12. Remove the planetary gear (12) of the opposite side travel motor in a similar procedure 3 to 11.

#### CAUTION

Avoid oil spills, use containers, rags, and/or paper towels to contain any oil leakage.

Dispose all waste oils, fluids, lubricants and other hazardous waste properly, according to government regulations.

Tow the machine to a safe place to proceed with the appropriate repairs.

13. After all repairs are completed, assemble the travel motor units.
14. Remove cover (2). See right figure.

#### CAUTION

Use caution when removing cover (2) because the ball (5) falls. If the ball (5) was contaminated, clean the ball (5).

15. Remove sun gear (6), then remove carrier assy (7) and thrust washer (13).
16. Then loosen capscrews (8) from carrier assy (7), and remove thrust washer (9).
17. Fit thrust washer (13) to carrier assy (7), then install inner ring (10), needle bearing (11) and planetary gear (12) to the shaft of carrier (7) in this order. And install thrust washer (9) with capscrews (8). Install all planetary gears (12) in the same way. Tightening torque :  $33.3 \pm 4.9 \text{ N}\cdot\text{m}$  { $3.4 \pm 0.5 \text{ kgf}\cdot\text{m}$ }

#### CAUTION

Remove completely the adhesive, which was left in the thread hole of shaft.

The residual adhesive causes loosening of capscrews.

18. Install carrier assy (7) to body (1).

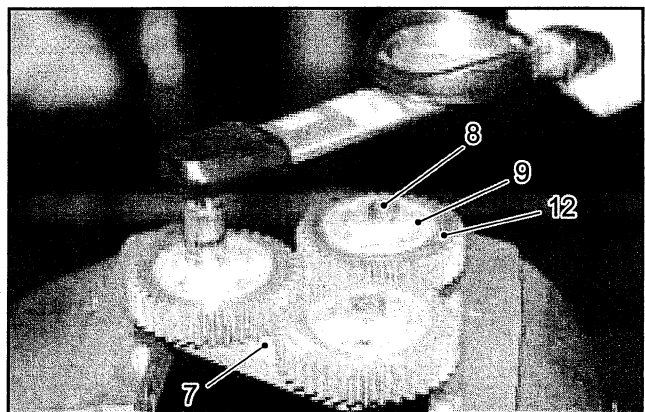
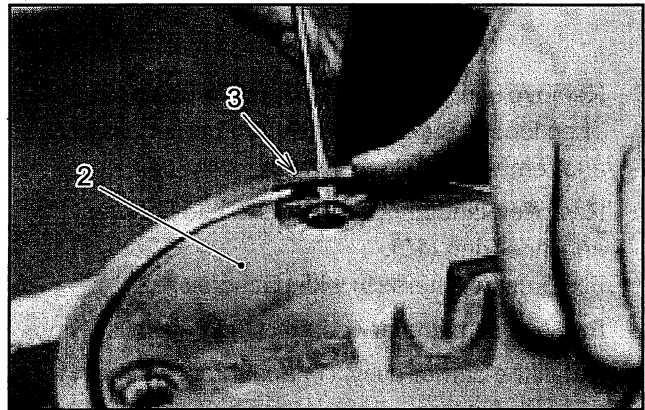
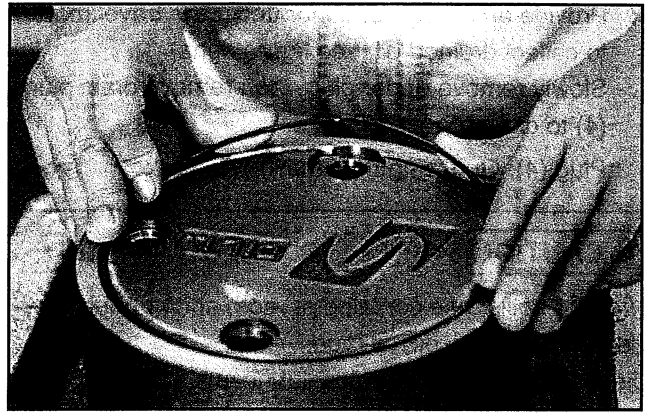

### 3. MACHINE OPERATION

#### 3.1.18 PRECAUTIONS WHEN STORING THE MACHINE FOR A LONG PERIOD

When storing the machine for more than one month, observe the following points to prevent the machine function from deteriorating.

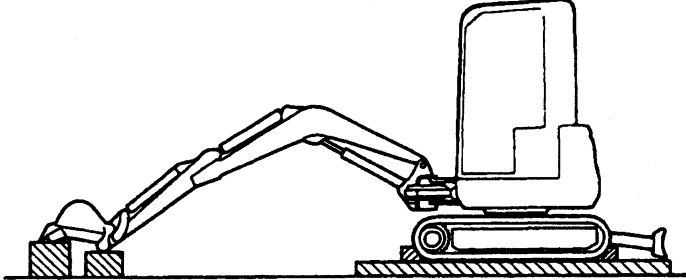
ITEM	ACTION
WASHING MACHINE	<p>Wash the machine thoroughly.</p> <p>Check the travel system for any malfunctions and service as required.</p> <p>Lubricate every required part.</p>
LUBRICATION	<p>Check the lubrication oil to make sure it is at the proper level and for contamination. Replenish if necessary, and change if contaminated.</p> <ul style="list-style-type: none"> <li>• Lubricating oil deteriorates even when the machine is not used.</li> <li>• Be sure to check the oil before operating the machine again.</li> </ul> <p>Apply sufficient rust inhibitors to portions where rust is likely to occur, especially the exposed rod of the cylinder.</p>
BATTERY	<p>Remove the negative terminal from battery and cover the battery, or remove the battery from the machine and store it at room temperature placing it over a wood deck.</p> <p>Charge the battery once a month to replenish spontaneous discharging.</p>
COOLANT	<p>If there is a possibility that the coolant may freeze, add antifreeze in the coolant.</p> <p>Normally, long life coolant is mixed in, so it is not necessary to change the coolant.</p>
DUST AND HUMIDITY PREVENTION	<div style="text-align: center;">  </div> <p>Keep the machine in a dry place indoors. If the machine must be kept outdoors, lay wood block on the flat ground and protect the machine with cover.</p> <ul style="list-style-type: none"> <li>• Park the machine with the exposed piston rod of the cylinder retracted as much as possible.</li> <li>• Get down the bucket to the ground and set the skids to the crawler.</li> </ul>
PERIODICAL OPERATION FOR LUBRICATION (DURING STORAGE)	<p>If the oil film on the parts is insufficient, and rust occurs and abnormal wear may occur when the machine is operated.</p> <p>Start the engine and operate the machine and attachment, etc. once a month to lubricate all of the parts.</p> <ul style="list-style-type: none"> <li>• Before starting the engine, check the engine oil and coolant level, and replenish if insufficient.</li> <li>• Wipe off the rust inhibitors from the cylinder and piston rod thoroughly.</li> <li>• Apply rust inhibitors to cylinder rods after the above operation.</li> <li>• After starting the engine, warm up the machine completely. Repeat travelling, slewing, and digging several times to lubricate each part of the machine.</li> <li>• Ensure proper ventilation during warming-up operation.</li> </ul>
OPERATION AFTER LONG TERM STORAGE	<p>Before placing the machine back into operation, proceed as follows before starting up.</p> <ul style="list-style-type: none"> <li>• Fully wiped off the rust inhibitors from the cylinders and piston rods.</li> <li>• Refill fluids to proper levels and lubricate as required.</li> </ul>

## 4. MAINTENANCE

### 4.3 LUBRICANT, FUEL & COOLANT SPECIFICATIONS

The following information is designed to allow usage of the proper oils, grease, fuels and coolants in various climates and certain working conditions.

Components	Type of Lubricant	Capacities (When changed)	Climate Zone								Specified Lubricant		
			-22° -30°	-4° -20°	14° -10°	32° 0°	50° 10°	68° 20°	86° 30°	104° 40°			
Hydraulic oil tank	Hydraulic tank	Tank : 38 liters {10 gal}									ISO VG 68	KW68	Genuine parts
		Total system : 48 liters {12.7 gal}				*					ISO VG 46	KW46	
		Automatic circulation of the above oil									ISO VG 32	KW32S	
Slewing motor													
Engine oil pan	Engine oil	H level : 6.7 liters {1.8 gal}										SAE 40	A.P.I. classification for "service CD"
		L level : 2.8 liters {0.74 gal}									SAE 30		
											SAE 10W		
						*					SAE 10W-30	*	
Fuel tank	Diesel fuel	38 liters {10 gal}										ASTM D-975 No.2	ASTM D-975 Grade 2-D
												ASTM D-975 No.1	ASTM D-975 Grade 1-D
Radiator	Coolant	Radiator: 1.6 liters {0.42 gal}											Antifreeze (if commercial coolant is used, the mixing rate of the LLC should conform with the specified.)
		Total : 4.6 liters volume {1.22 gal}										30% LLC mixture	
												50% LLC mixture	
Travel motor	Gear oil	0.7 liters {43 cu-in} X 2										EXTREME GEAR OIL SAE #90	A.P.I. classification for "service GL-4"
Upper rollers		45 cc {2.7 cu-in} X 2										EXTREME GEAR OIL SAE #90	
Idlers		80 cc {4.9 cu-in} X 2										EXTREME GEAR OIL SAE #90	
Attachment and dozer pin	Grease	20-places											Extreme pressure Multipurpose grease N.L.G.I No.2 Lithium base grease EP type
Swing cylinder pin													
Slewing bearing		1-place										Cartridge 2421Z183	
Idler adjuster		2-places											
Operating lever & pedal		As required										Pail can 2421Z213	
Slewing gear	Grease	1-place										N.L.G.I No.2 Lithium base with MoS <sub>2</sub> grease	

**Note :** Machines are shipped from factory with \* marked oil.

#### Note

#### USE OF BIO-DEGRADABLE OILS

When you use Bio-degradable Oil (BIO OIL), refer to the following information.

1. There are two types of BIO OIL available; vegetable-based and synthetic-based. You are recommended to use the synthetic-based type, because the vegetable-based oil has a maximum usage temperature of 80°C {176°F}. Because of this, the degradation of vegetable-based oil occurs more rapidly, and causes reduced service life.
2. Do not mix either type of BIO OIL with the original factory-filled mineral oil, in the case that you do use BIO OIL, it is required to flush the hydraulic system that was filled with BIO OIL oil three times.
3. If you use BIO OIL, slewing and propel parking brake performance will be reduced, because of the lower friction factor of BIO OIL compared to that of mineral oil.
4. For further information about recommended Bio-degradable oil, please contact our distributor.

## 4. MAINTENANCE

### 4.11 REPLACEMENT OF RUBBER CRAWLER SHOE

#### **WARNING**

- THIS WORK MUST BE CARRIED OUT WITH A PAIR OF TWO PERSONS. THE OPERATOR OPERATES THE MACHINE IN ACCORDANCE WITH THE SIGNAL OF THE PARTNER. THE RUBBER CRAWLER SHOE REPLACEMENT IS CARRIED OUT LIFTING THE MACHINE BODY. ERRONEOUS FALLING OF THE MACHINE BODY DURING THE WORK ON THE CRAWLER SHOE IS QUITE DANGEROUS. DO NOT OPERATE ANY OTHER ATTACHMENTS THAN THE CRAWLER.
- GREASE IN TRACK TENSIONING MECHANISM IS UNDER EXTREME PRESSURE AND CAN PENETRATE SKIN CAUSING SEVERE INJURY. KEEP FACE AND BODY AWAY FROM GREASE FITTING AREA. NEVER LOOSEN GREASE FITTING MORE THAN ONE TURN. IF GREASE DOES NOT RELEASE AFTER ONE TURN OF THE FITTING, CALL OUR DISTRIBUTOR FOR ASSISTANCE.
- BEFORE REMOVING THE RUBBER CRAWLER SHOE, CONFIRM THAT THE PRESSURE INSIDE GREASE HAS BEEN COMPLETELY RELEASED. THEN TURN THE SPROCKET.
- IT IS QUITE DANGEROUS TO ALLOW THE SPOUTING OUT OF GREASE WITH ANY PROCEDURES OTHER THAN THE ONE DESCRIBED IN THE, "REMOVAL OF RUBBER CRAWLER SHOE". IF THE TENSION ON THE CRAWLER SHOE IS NOT RELEASED, CONSULT WITH OUR DISTRIBUTOR FOR ITS REPAIR.

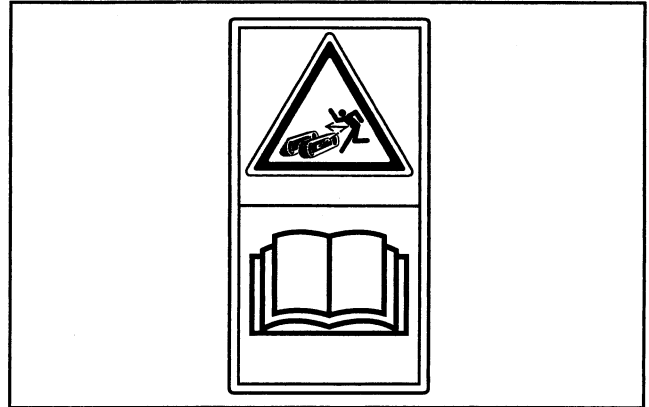

#### 4.11.1 REMOVAL OF RUBBER CRAWLER SHOE

1. Operate boom, arm, and bucket to set the attachment on the ground.  
Slowly and gradually lower the boom to lift one side of the machine.
2. Support the lower travel structure of the machine with a safety support (1), etc.

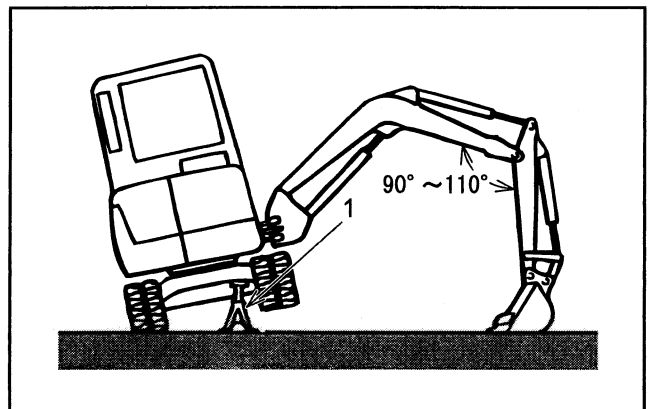

## 4. MAINTENANCE

### B. CLEANING OR REPLACEMENT OF RADIATOR CAP

#### **WARNING**

USE EXTREME CARE WHEN REMOVING THE RADIATOR CAP. THE COOLANT IS UNDER HIGH PRESSURE WHEN HOT.

- NEVER REMOVE THE RADIATOR CAP WHEN THE SYSTEM IS HOT.
- ALLOW SUFFICIENT TIME FOR THE MACHINE TO COOL DOWN BEFORE REMOVING THE RADIATOR CAP.

#### **CAUTION**

If the tightness of cap is insufficient, it may cause for danger of getting burned due to spouting out of hot water or steam during operation.

1. Remove the radiator cap after the engine has cooled down to touchable with a bare hand. Slowly loosen the cap to release the inside pressure. Remove the radiator cap after all pressure is released.
2. Check the cap for damages or adhesion of dust. Clean it and/or replace it if needed.
3. Securely tighten the cap.

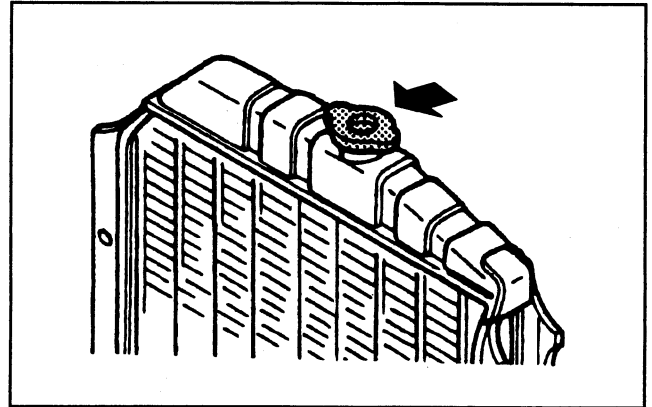

### C. REPLACEMENT OF WORKING LIGHT

A light bulb of 55W is used for the working light.

#### **CAUTION**

Since the light bulb develops high temperature while working, the service life of the light bulb becomes shorter if oil or grease adhered on it.

When replacing the light bulb, hold it at the flange portion not touching with its glass portion.

When the working light is not lightened even though the switch for working light is turned on, the light bulb or fuse may be blown out. If there is no trouble on the light bulb, check the fuse referring to 2-22. The following is the description for the changing procedures of light bulb.

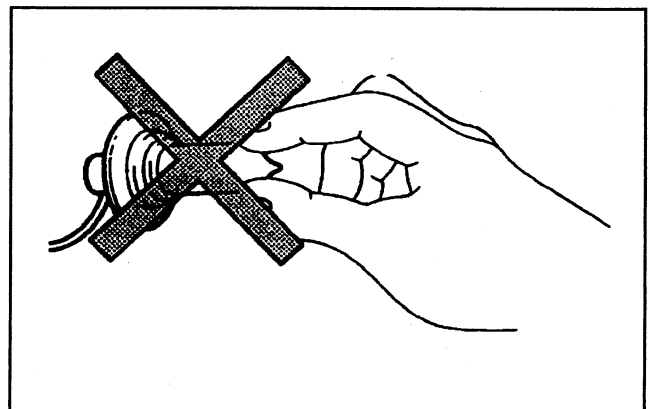

## 4. MAINTENANCE

Hydraulic oil leakage will slow down a machine. Move the machine to firm level ground and place the attachment in the oil check position and stop the engine.

1. Set the safety lock lever to "LOCKED" position, then stop the engine.
2. To check the location of leakage, take a time to allow getting the temperature on each portion of the machine down to around 40°C {104°F}.  
Make sure to wear the protective glasses and gloves for the check.
3. Press breather valve with rubber cap on the upper surface of hydraulic tank several times (5 to 7 times) and release the pressure in the hydraulic tank.

1. HYDRAULIC TANK
2. AIR BREATHER

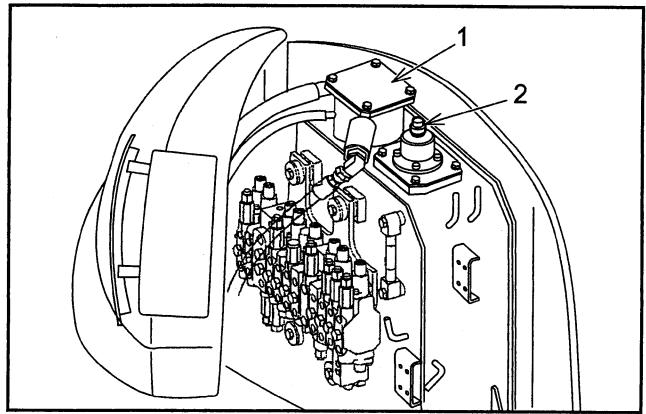

### Note

When any abnormalities happen on the machine, immediately stop the work, and ask the repair to our distributor.

When the volume becomes insufficient for the engine coolant or oil due to leakage, and warning lamp is illuminated.

## D. CHECK TRAVEL SYSTEM FOR LEAKAGES AND ABRASION

1. TRAVEL MOTOR
2. SPROCKET
3. LOWER ROLLER
4. CRAWLER SHOE
5. UPPER ROLLER
6. IDLER

1. Check the lower roller, idler and travel motor for any leakages.
2. Check the lower roller, idler and sprocket for abnormal wear and loosened fixing bolts.
3. Slowly travel the machine and check for any abnormal sound.

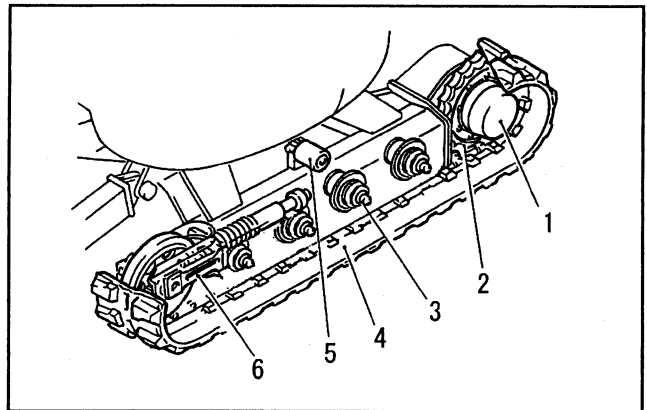

### Note

Consult with our distributor for advise and/or repairs as needed.

## 4. MAINTENANCE

1. Stop the engine, and open the engine guard, and remove the under cover.
2. Apply the filter wrench (2) to the filter cartridge (1), and turn the wrench with spanner to counter-clockwise to remove it.
3. Wipe off any dust on the seal face of filter base, and avoid contamination.

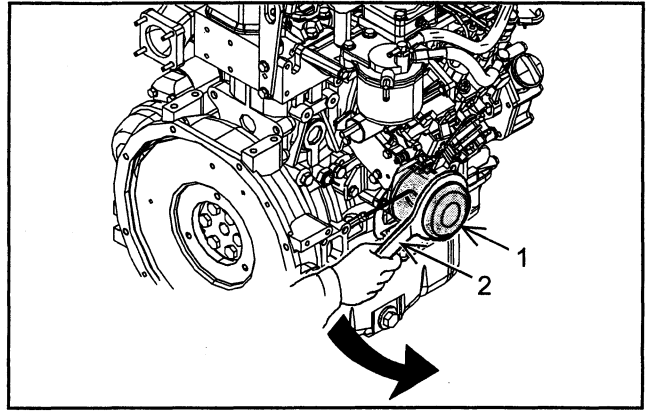

REMOVAL OF ENGINE OIL FILTER

4. Thinly apply clean engine oil to the packing (A) of new filter cartridge, and install and tighten it up with hand. Then retighten it by about 2/3 turns.
5. Start up the engine, and operate it at idling for several minutes to check for any leakage at the installing face.
6. Close the engine guard and install the under cover.

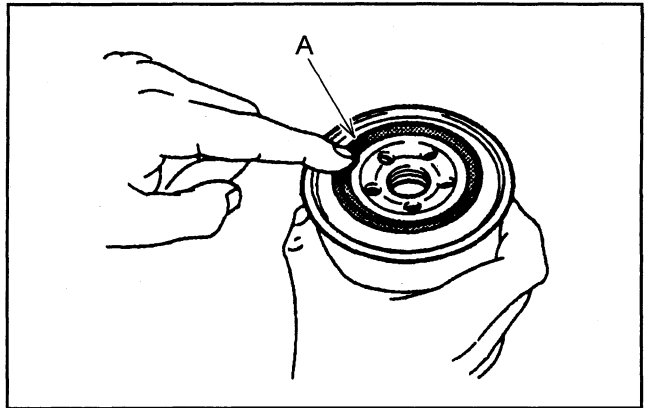

### Note

- When the machine is operated in dusty circumstances, a shorter interval is required for the replacement.
- When some metal particles are adhered on the element removed, consult it with our distributor.

### CAUTION

Dispose of all hazardous waste in accordance with government environmental regulations.

## F. CHECKING RADIATOR HOSE

Replacing the hoses before any problems occur is both economical and good maintenance practice. This will reduce costs and minimize unexpected interruption of working. Immediately replace the hose if it is cracked, worn, or if water is leaking from it. This will prevent serious problems, such as the engine overheating.

1. Check the hoses for water leakage due to loose clamps or cracked and worn hoses.
2. Tighten any loose clamps and replace any cracked or worn hoses following the procedures below.

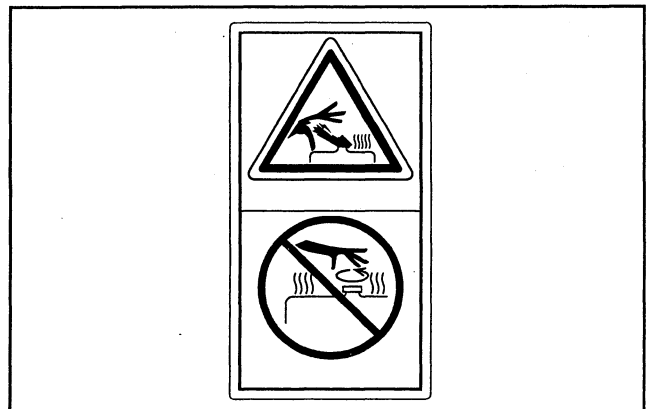

## 4. MAINTENANCE

8. Remove the suction strainer (6).
9. Remove the dust, etc. adhered on suction strainer (6) and wash it with clean diesel fuel or wash solvent. When suction strainer (6) is damaged, replace it with new one.

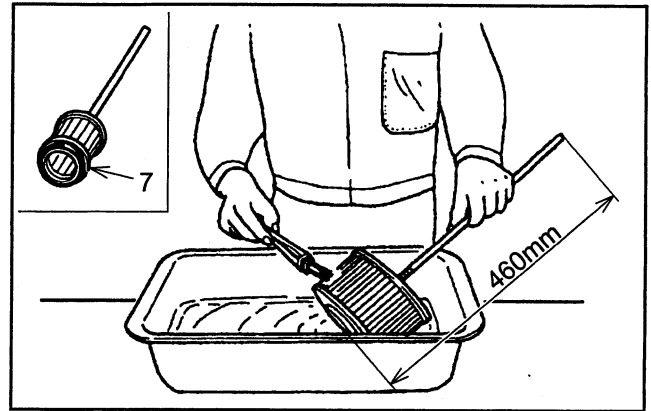

10. Check the bottom of strainer (6) and O-ring (7) for possible damage. When it is worn or damaged, replace it with new one.
11. Insert and fit suction strainer (6).
12. Fill the hydraulic oil tank with the hydraulic oil from filling port (F) referring to the item "**LUBRICANT, FUEL & COOLANT SPECIFICATIONS**".
13. Install cover (4) with capscrew (2) and lock washer (3).  
Tightening torque :  $23.5 \pm 2 \text{ N}\cdot\text{m}$  { $17 \pm 1.4 \text{ lbf}\cdot\text{ft}$ }
14. Install the right side guard.
15. After starting the engine and rotating it for several minutes (5 to 7) at low idling speed, carry out the telescopic motion of each cylinder and the slewing operation, return the machine to the hydraulic oil level check position, and after oil level check, make up the shortage of oil.

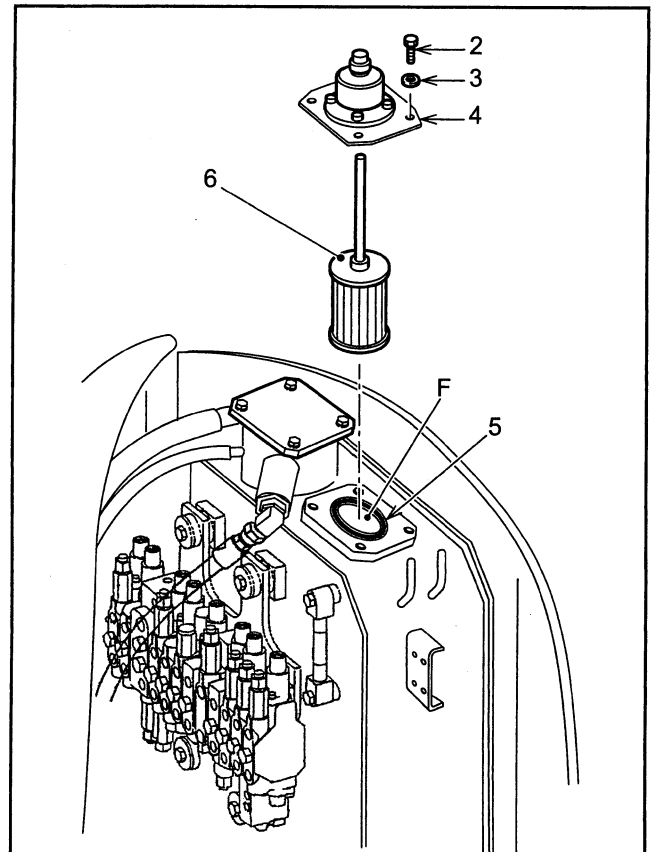



## 6. SPECIFICATIONS

### 6.1.2 GENERAL SPECIFICATIONS

#### A. SPEED AND GRADEABILITY

Item	Rubber crawler shoe		Iron crawler shoe	
Slewing Speed	8.9 min <sup>-1</sup> {8.9 rpm}			
Travel Speed	Low (1st)	High (2nd)	Low (1st)	High (2nd)
	2.5 km/h	4.5 km/h	2.5 km/h	4.5 km/h
Gradeability	58% (30°)			

#### B. ENGINE

Model	YANMAR 3TNV88 - PYB
Type	Water-cooled, 4-cycle type Swirl chamber type diesel engine
Number of cylinders-Bore x Stroke	3 - 88 mm × 90 mm {3 - 3.46" × 3.54"}
Total Displacement	1.642 liters {100.2 cu·in}
Output Rating	21.2 kW / 2,400 min <sup>-1</sup> {29 PS / 2,400 rpm}
Maximum Torque	98.4 N·m / 1,440 min <sup>-1</sup> {72.6 lbf·ft / 1,440 rpm}
Starting Motor	12 V / 1.7 kW
Generator	12 V / 55 A

#### C. HYDRAULIC COMPONENTS

Hydraulic Pump	Variable displacement axial piston + gear pump
Hydraulic Motor	Axial piston
Hydraulic Motor w/Reducer (Travel)	2-Axial piston, 2-Speed motor
Control Valve	10-spool multiple control valve
Cylinder (Boom, Arm, Swing, Bucket, Dozer)	Double action cylinder
Return Filter	Safety valve containing/Filter Type (30μ)

#### D. SIDE DIGGING & DOZER

Type	Boom swing by hydraulic cylinder	
Boom Swing Angle	Right	60°
	Left	70°
Stroke of Dozer (above/below)	mm {in}	540 / 440 {21.3 / 17.3}

## 7. OPTIONAL EQUIPMENT

### 7.1.6 SETTING STOP VALVE

Stop valve on arm top end is used to stop hydraulic oil flowing.

Stop (A) : Hydraulic oil stops flowing.

Free (B) : Hydraulic oil flows.

Before removing attachment, set stop valve to "STOP" position.

1. PLUG
2. ARM
- A. STOP POSITION
- B. FREE POSITION
- C. 19 mm {Hex}

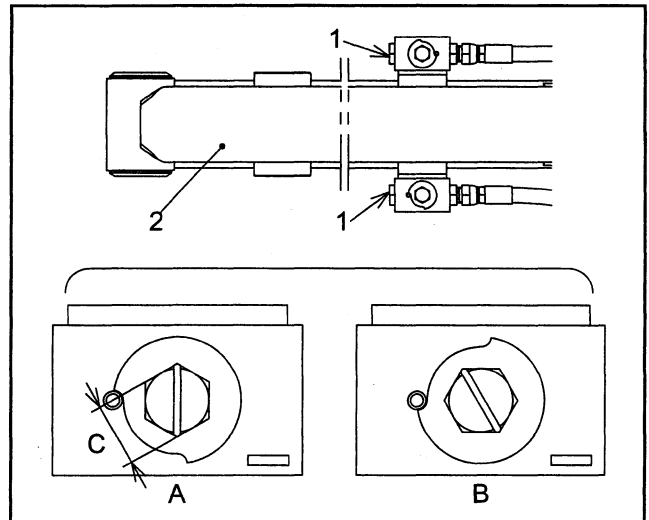

## 8. TROUBLESHOOTING

SYS	PROBLEM	PROBABLE CAUSE	POSSIBLE REMEDY
TRAVEL	2. Traveling power is insufficient.	a. Hydraulic pump is damaged	Repair or replace
		b. Poor engine performance	Repair or replace
		c. Main relief valve pressure is set incorrectly	Adjust or replace
		d. Low hydraulic oil level	Fill to proper level
		e. Hydraulic motor (travel) is not working	Repair or replace
		f. Brake valve is not working	Repair or replace
		g. Seal in swivel joint is scored or oil is leaking	Repair or replace
	3. Machine does not travel in a straight line.	a. Unequal tensions on crawlers	Adjust tension.
		b. Set pressures of main relief valves unbalanced	Adjust.
		c. Performances of hydraulic travel motor has deteriorated	Repair or replace.
		d. Unbalanced flow from control valve	Repair or replace.
		e. Unbalanced discharge from hydraulic pump	Repair or replace.
		f. Unbalanced flow from brake valve	Repair or replace.
g. Unbalanced flow between RH swivel joints	Repair or replace.		
HYDRAULIC	1. Temperature rise in the hydraulic oil temp.	a. Oil cooler core clogged	Clean
		b. Engine fan belt slipping	Adjust or replace
		c. Low hydraulic oil level	Refill to specified level
		d. Wrong type hydraulic oil used	Replace with correct, new oil
		e. Hydraulic pump is not working	Repair or replace
GAUGE CLUSTER DISPLAY	1. Engine oil pressure is too low.	a. Engine oil level low	Fill to specified level
		b. Oil leaking	Repair & fill to proper level
		c. Wrong oil viscosity	Replace with proper oil
	2. Abnormal rise in the coolant temperature.	a. Low coolant	Fill to proper level
		b. Coolant leaking	Repair & fill to proper level
		c. Loose radiator cap	Tighten
		d. Radiator core clogged	Clean cooling system
		e. V-belt loose or damaged	Tighten to proper tension
		f. Rust or scale in coolant	Flush system/fill to level
		g. Faulty thermostat	Replace
	3. Battery charge.	a. Battery terminals disconnected, loose, or corroded	Clean and connect
		b. Low battery electrolyte	Replenish
		c. Slipping of V-belt or damaged	Adjust or replace
d. Battery service life has run down		Replace	
ENGINE	1. Starter does not turn or turns slowly which does not start the engine.	a. Battery disconnected	Connect
		b. Battery discharged	Charge
		c. Battery terminals disconnected, loose, or corroded	Clean and connect
		d. Ground cable disconnected	Connect
		e. Engine oil viscosity too thick (Cold Weather)	Change to proper oil
	2. Starter turns but engine does not start.	a. Insufficient fuel	Refuel
		b. Improper starting procedure	Refer to "chapter 3. MACHINE OPERATION"
		c. Air in fuel line	Remove (See 4-19)
		d. Clogged fuel filter	Replace element
		e. Clogged air cleaner	Replace elements
		f. Air heater circuit malfunctioning	Check circuit

CLICK HERE TO **DOWNLOAD** THE COMPLETE MANUAL

- Thank you very much for reading the preview of the manual.
- You can download the complete manual from: [www.heydownloads.com](http://www.heydownloads.com) by clicking the link below



- Please note: If there is no response to CLICKING the link, please download this PDF first and then click on it.

CLICK HERE TO **DOWNLOAD** THE COMPLETE MANUAL