



67Z7B

(CUMMINS QSB4.5)

93307-00680



93307-00680

July 2017

PARTS CATALOG

WHEEL LOADER

67Z7B

EQUIPMENT COMPONENTS PARTS

Powered by CUMMINS QSB4.5 Engine

Serial No. 65C5-5001 ~

CLICK HERE TO **DOWNLOAD** THE COMPLETE MANUAL

- Thank you very much for reading the preview of the manual.
- You can download the complete manual from: www.heydownloads.com by clicking the link below



- Please note: If there is no response to CLICKING the link, please download this PDF first and then click on it.

CLICK HERE TO **DOWNLOAD** THE COMPLETE MANUAL

MEMO

VALVE;CONTROL (FOR FAN MOTOR ROTATION SWITCHING)

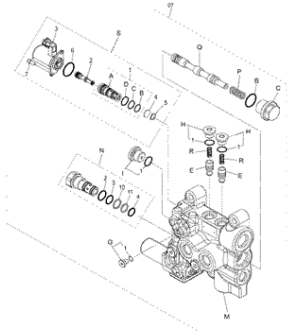

DCEY86009896

.....p.61

VALVE;PILOT (WORK LEVER)

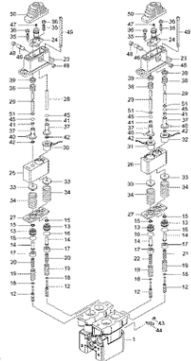

DCEY86122952

.....p.63

VALVE;PILOT (AUXILIARY LEVER)



DCEY86203888

.....p.65

VALVE;STEERING

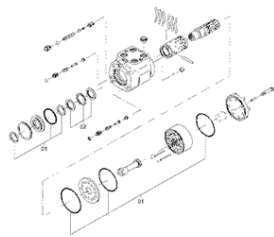

DCEY860913383

.....p.67

VALVE;SOLENOID (PILOT)

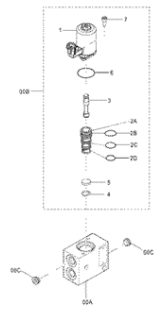

DCEY86008684

.....p.69

VALVE;BRAKE

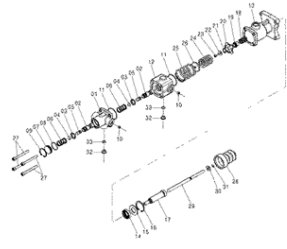

DCEY860913272

.....p.71

VALVE;PRIORITY

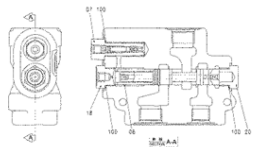

DCEY860913285

.....p.73

VALVE (BRAKE CHARGE)

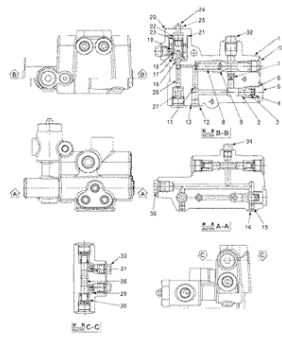

DCEY860028728

.....p.75

VALVE (MANIFOLD)

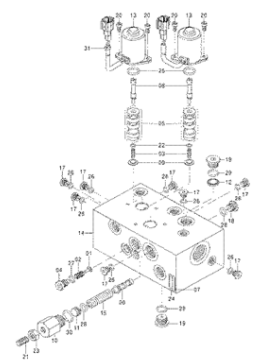

DCEY86002869

.....p.77

ROTOR; GROUP
 ロータ;グループ

Applicable Model (適用機種): -

Mark (記号): -

Serial No. (適用号機): -

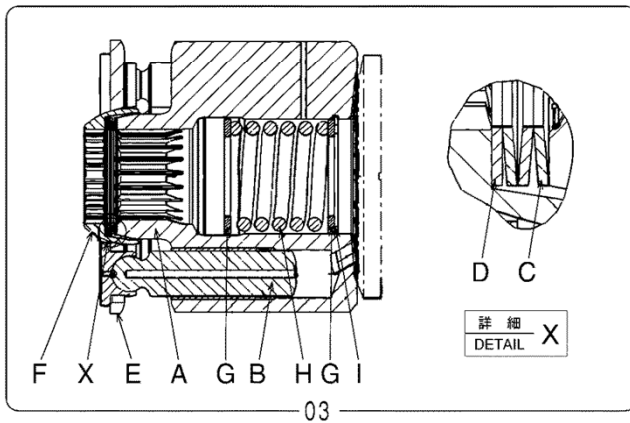
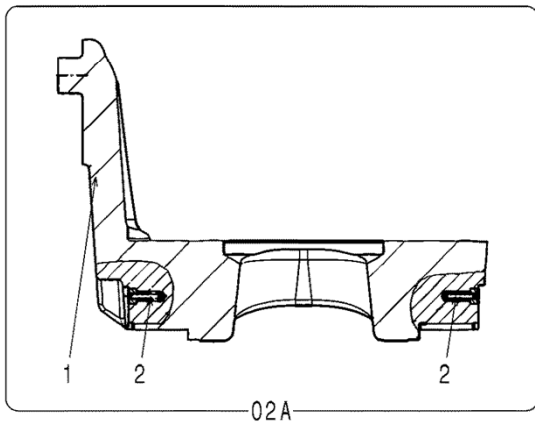
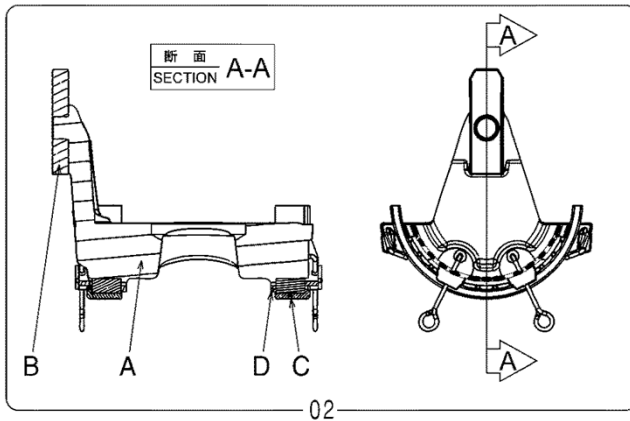
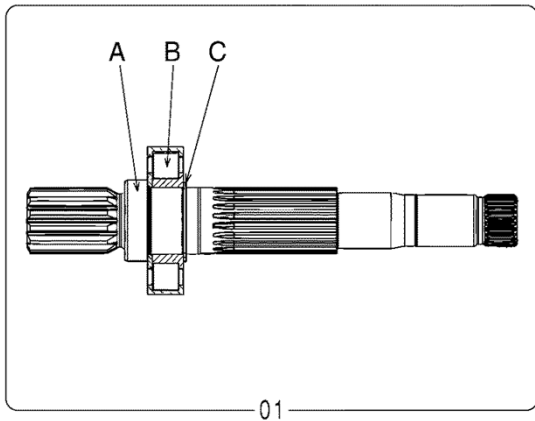
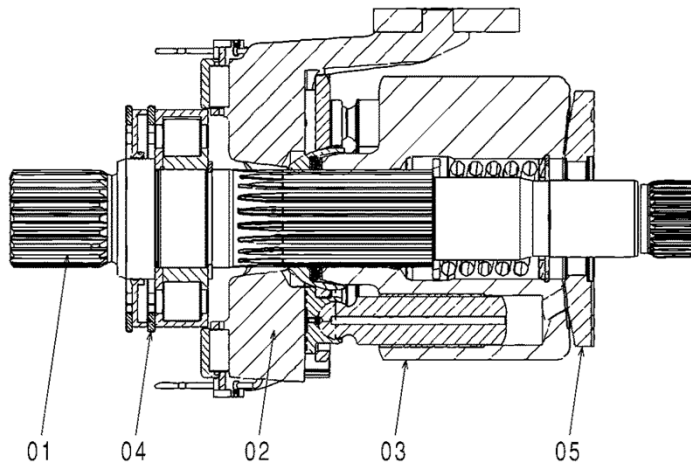

DCEXA00000183

GEAR; INTERNAL
 ギヤ; インターナル

Applicable Model (適用機種): -

Mark (記号): -

Serial No. (適用号機): -

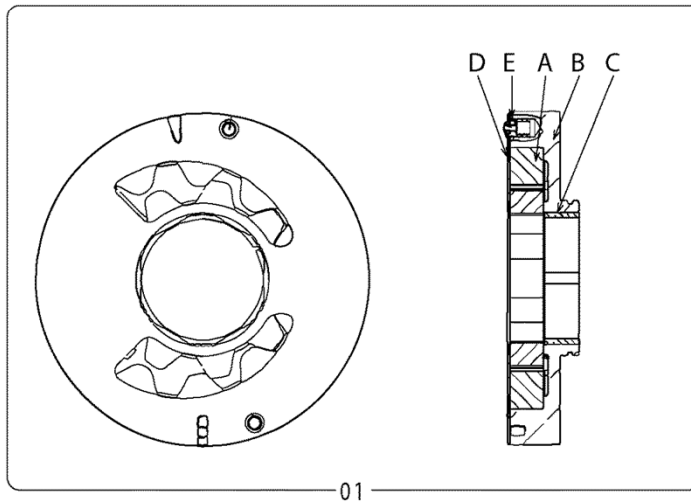
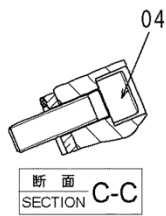
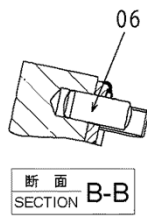
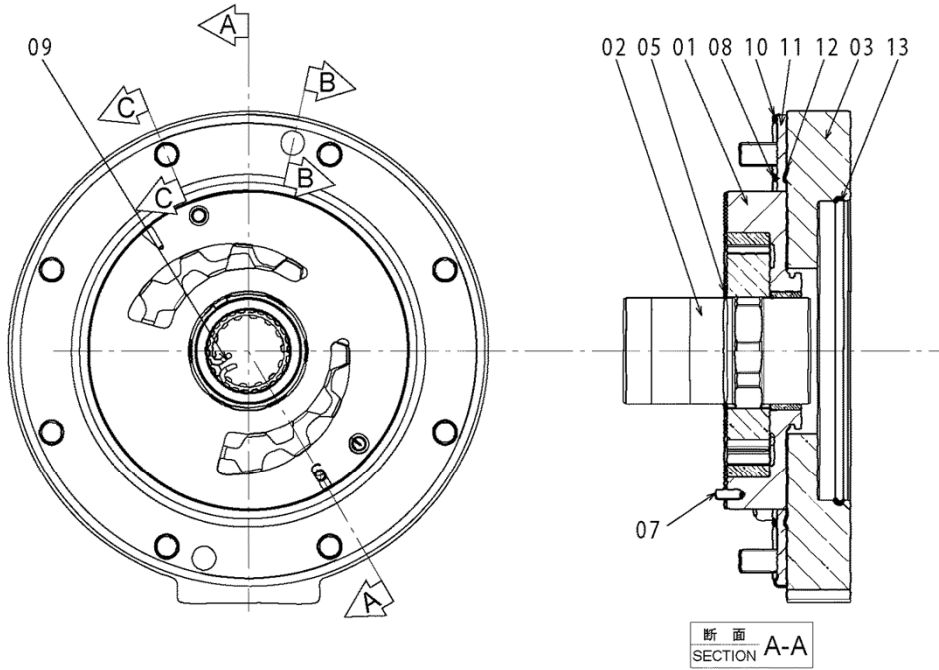

DCEXA00000186A

ROTOR; GROUP
 ロータ;グループ

Applicable Model (適用機種): -

Mark (記号): -

Serial No. (適用号機): -

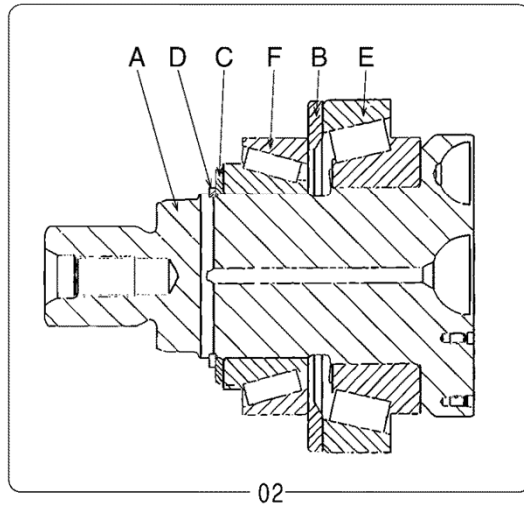
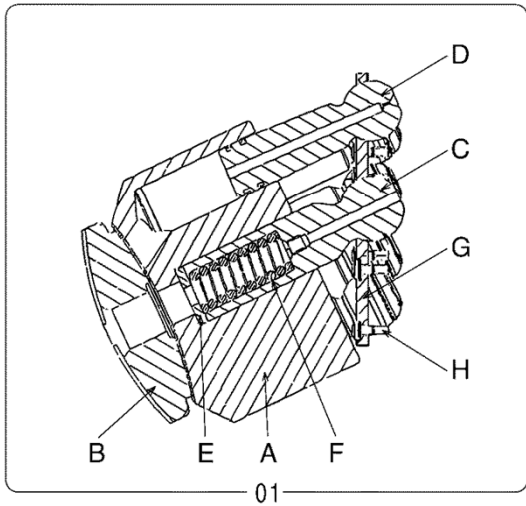
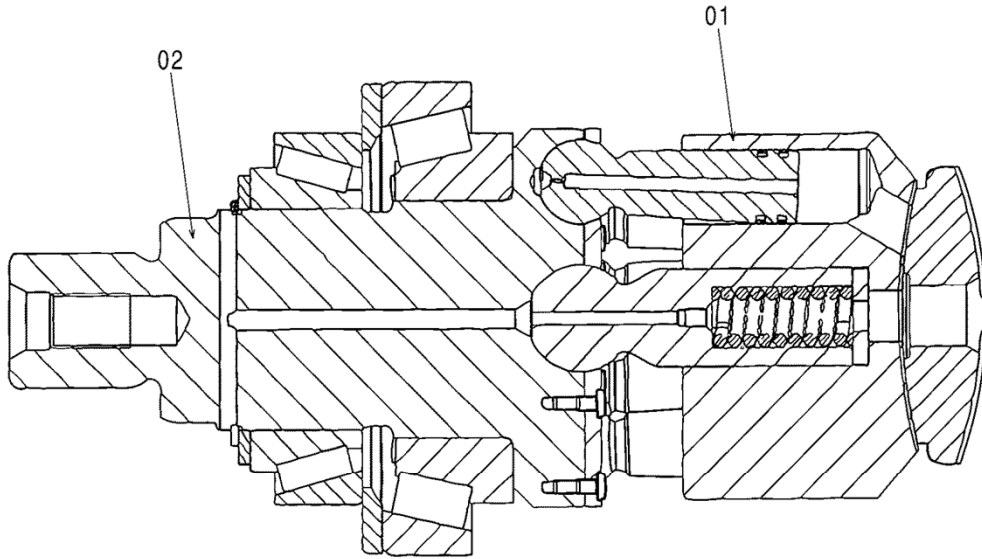

DCEXA00000176

CLICK HERE TO **DOWNLOAD** THE COMPLETE MANUAL

- Thank you very much for reading the preview of the manual.
- You can download the complete manual from: www.heydownloads.com by clicking the link below



- Please note: If there is no response to CLICKING the link, please download this PDF first and then click on it.

CLICK HERE TO **DOWNLOAD** THE COMPLETE MANUAL

HOUSING ハウジング

Applicable Model (適用機種): -

Mark (記号): -

Serial No. (適用号機): -

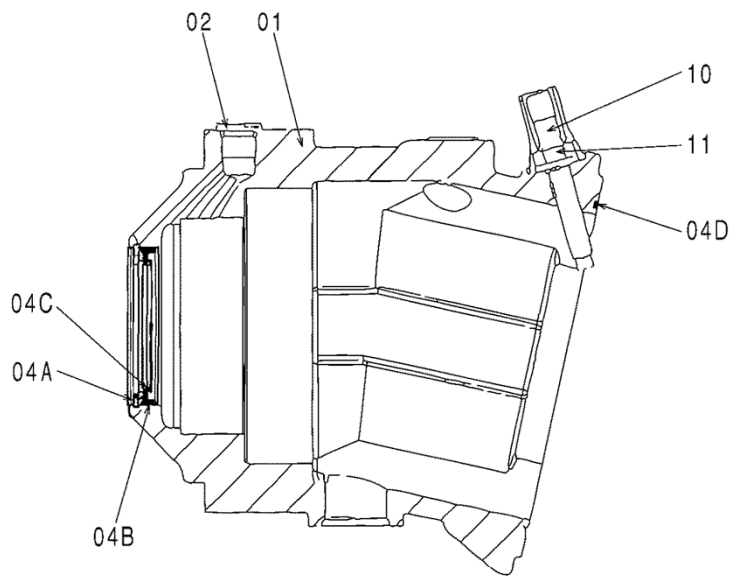

DCEXA00000180

VALVE;CONTROL (3 SPOOL)
 バルブ;コントロール (3連)

Applicable Model (適用機種): -

Mark(記号): -

Serial No. (適用号機): -

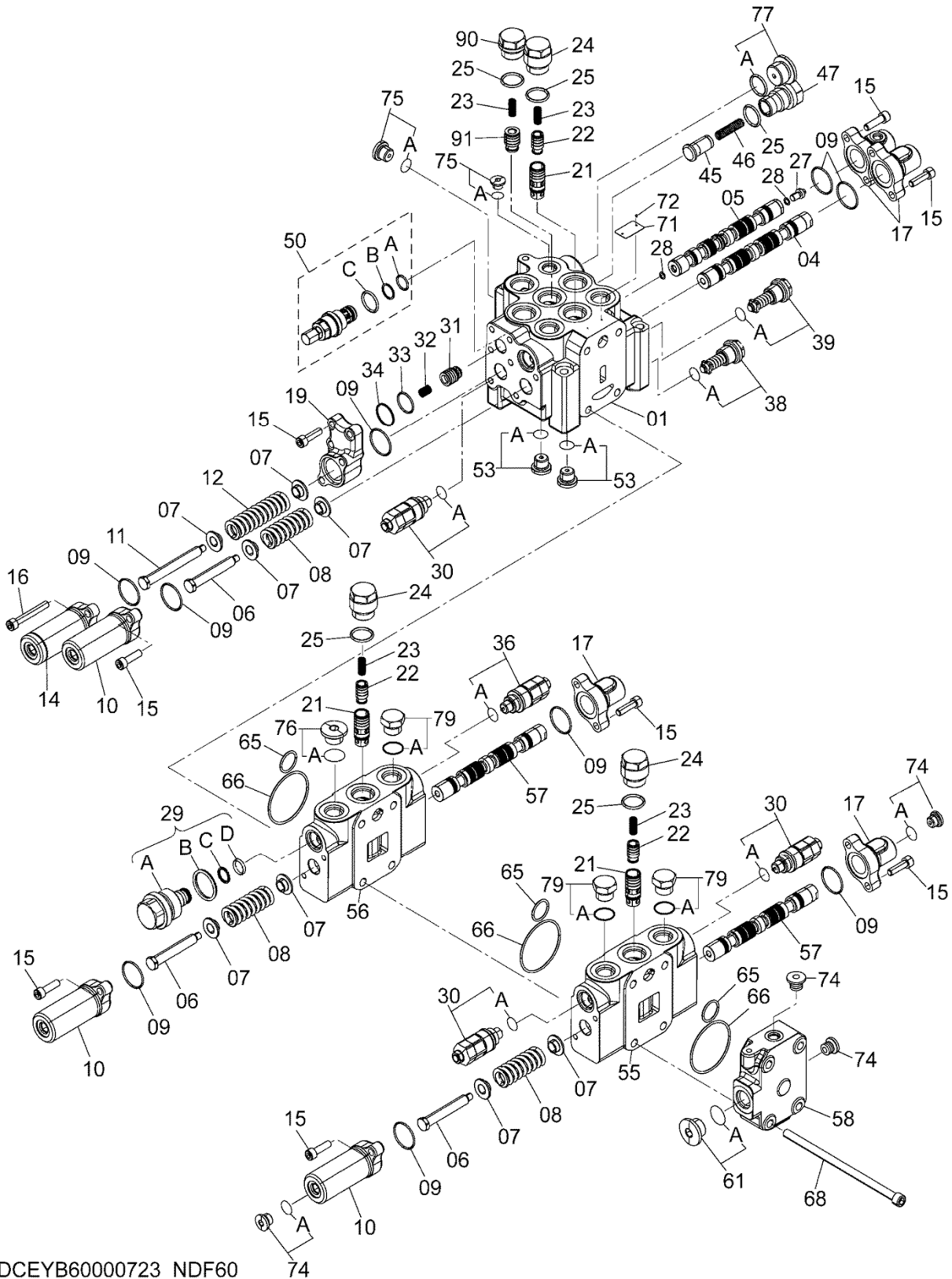

DCEYB60000723_NDF60

VALVE;PILOT (WORK LEVER)
バルブ;パイロット (作業レバー)

Applicable Model (適用機種): -

Mark(記号): -

Serial No.(適用号機): -

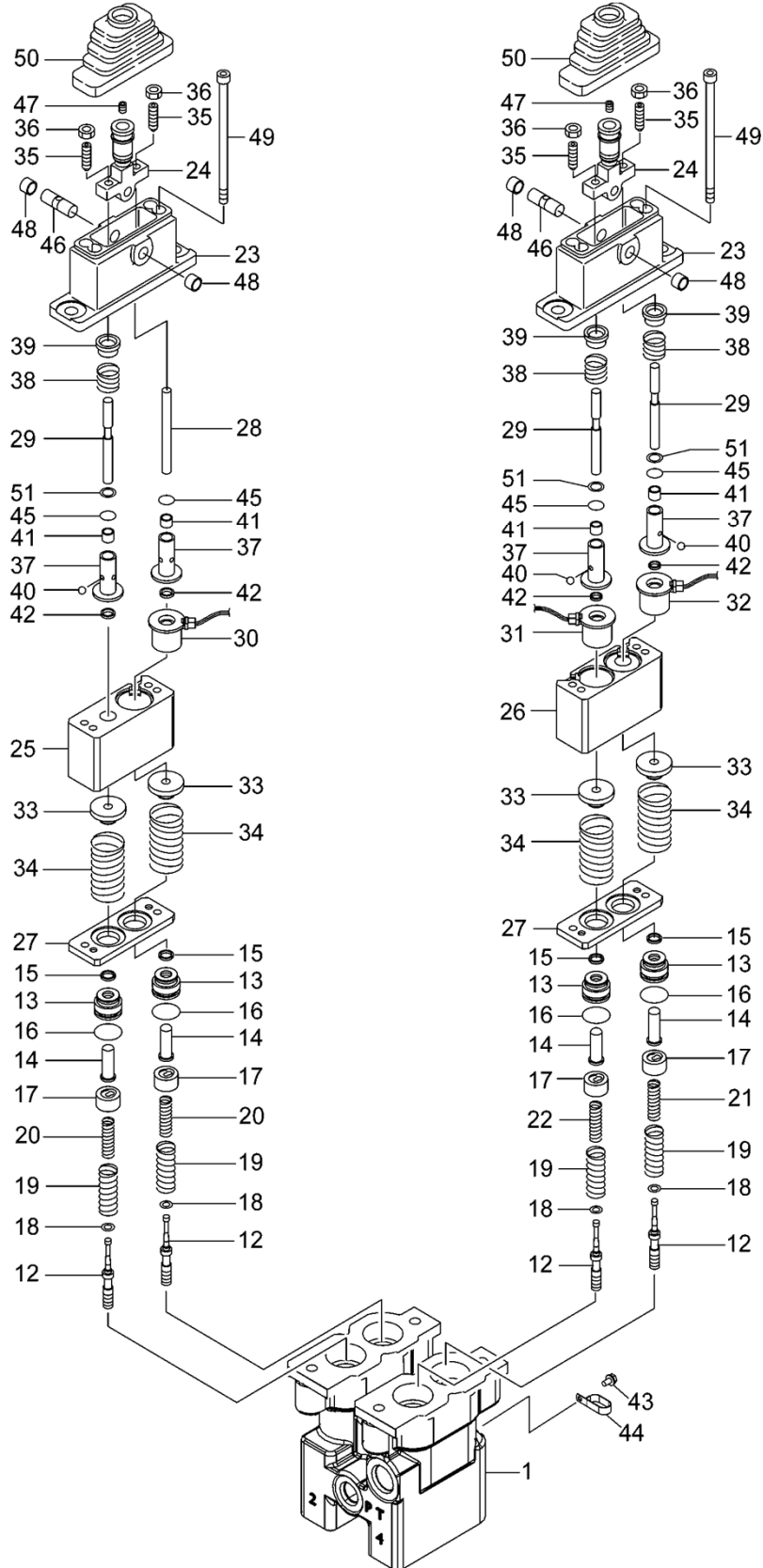

DCE263G732052

VALVE;PRIORITY
バルブ;プライオリティ

Applicable Model (適用機種): -

Mark(記号): -

Serial No. (適用号機): -

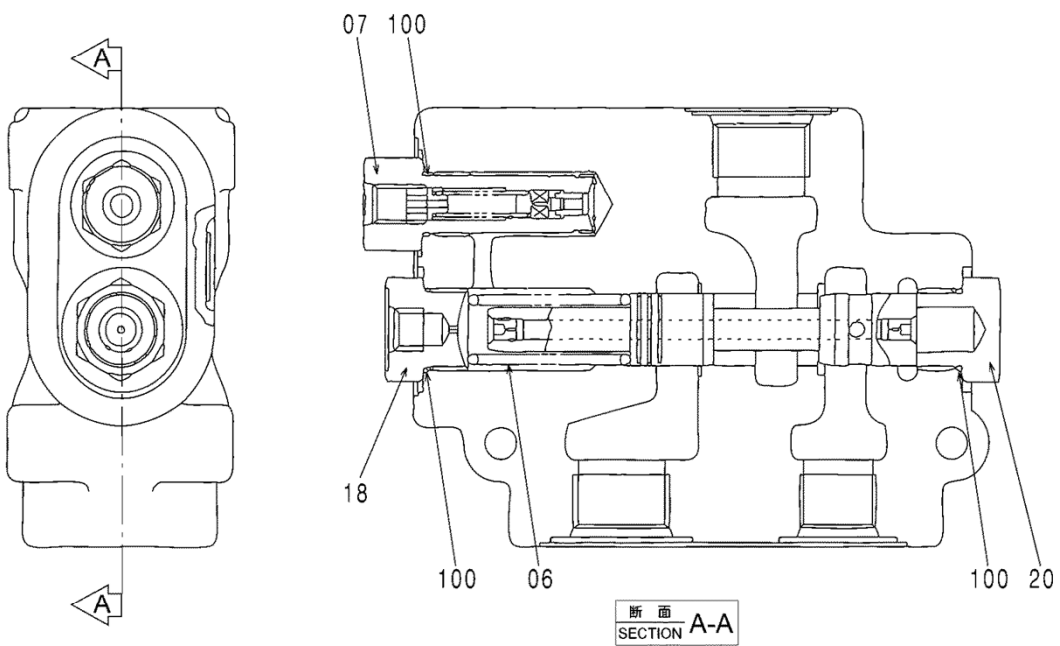

DCEYA00013290

CYL. ;BUCKET
 シリンダ;バケット

Applicable Model (適用機種): -
 Mark(記号): -
 Serial No. (適用号機): -

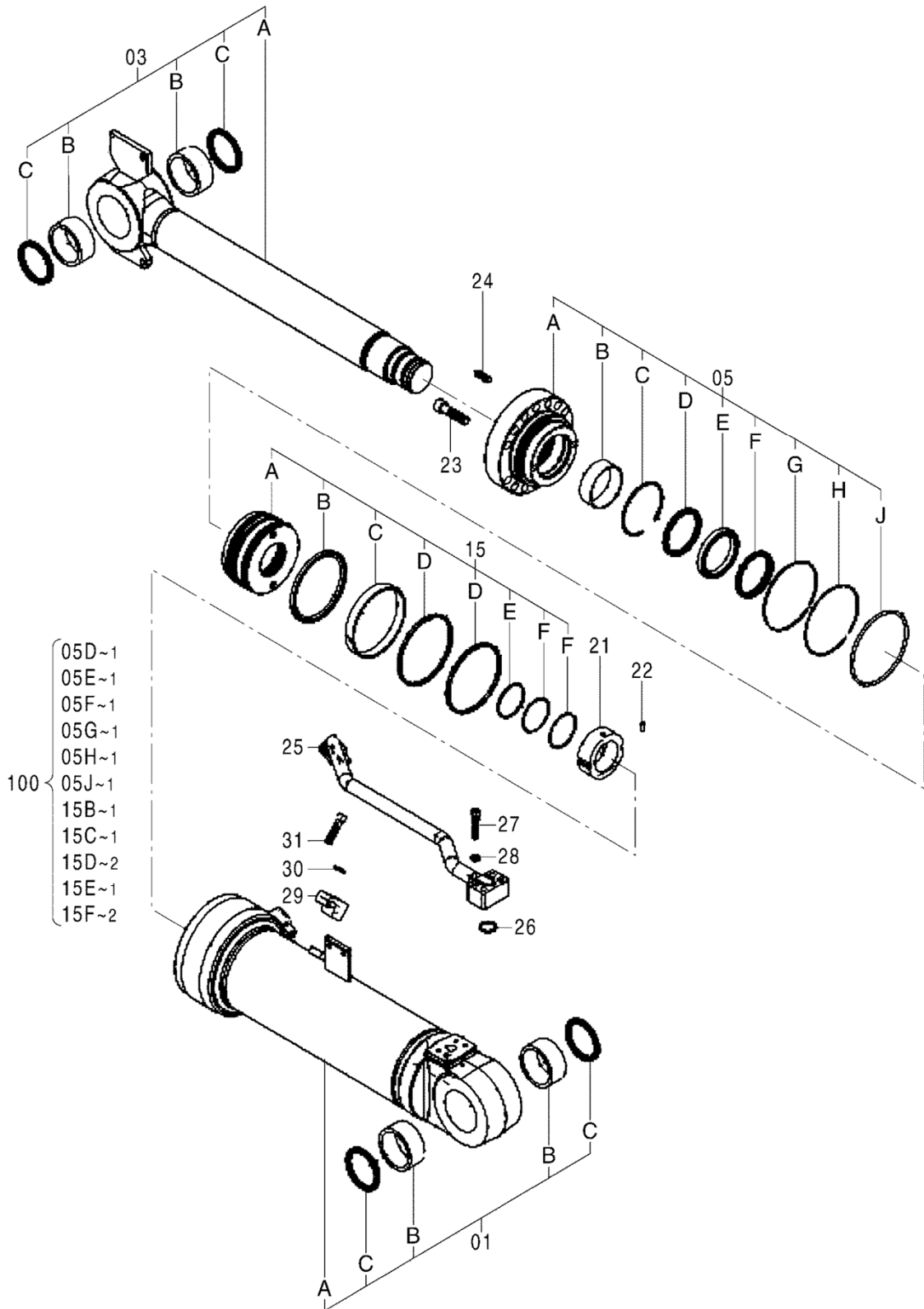

DCEYA00013286

TRANSMISSION (2/6)

トランスミッション (2/6)

Applicable Model (適用機種): -

Mark (記号): -

Serial No. (適用号機): -

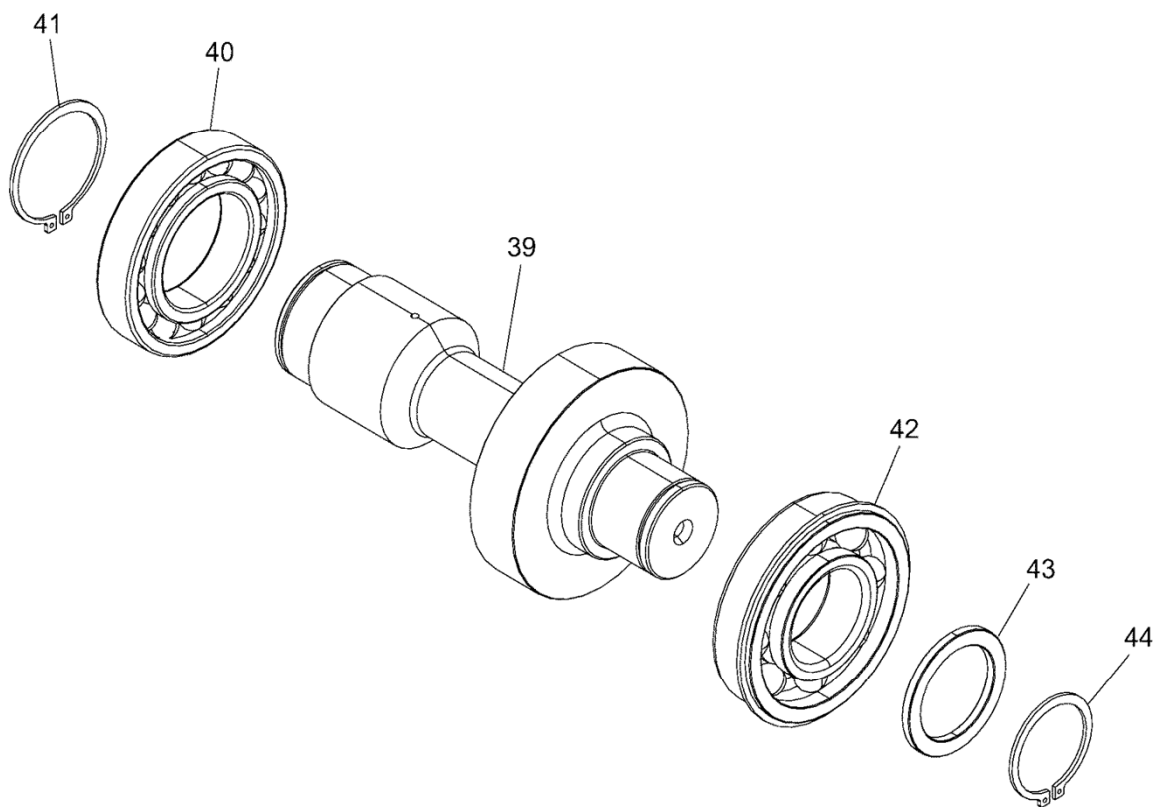

DCEYB60000888_2

DIFFERENTIAL (LSD) ディファレンシャル (LSD)

Applicable Model (適用機種): -

Mark (記号): -

Serial No. (適用号機): -

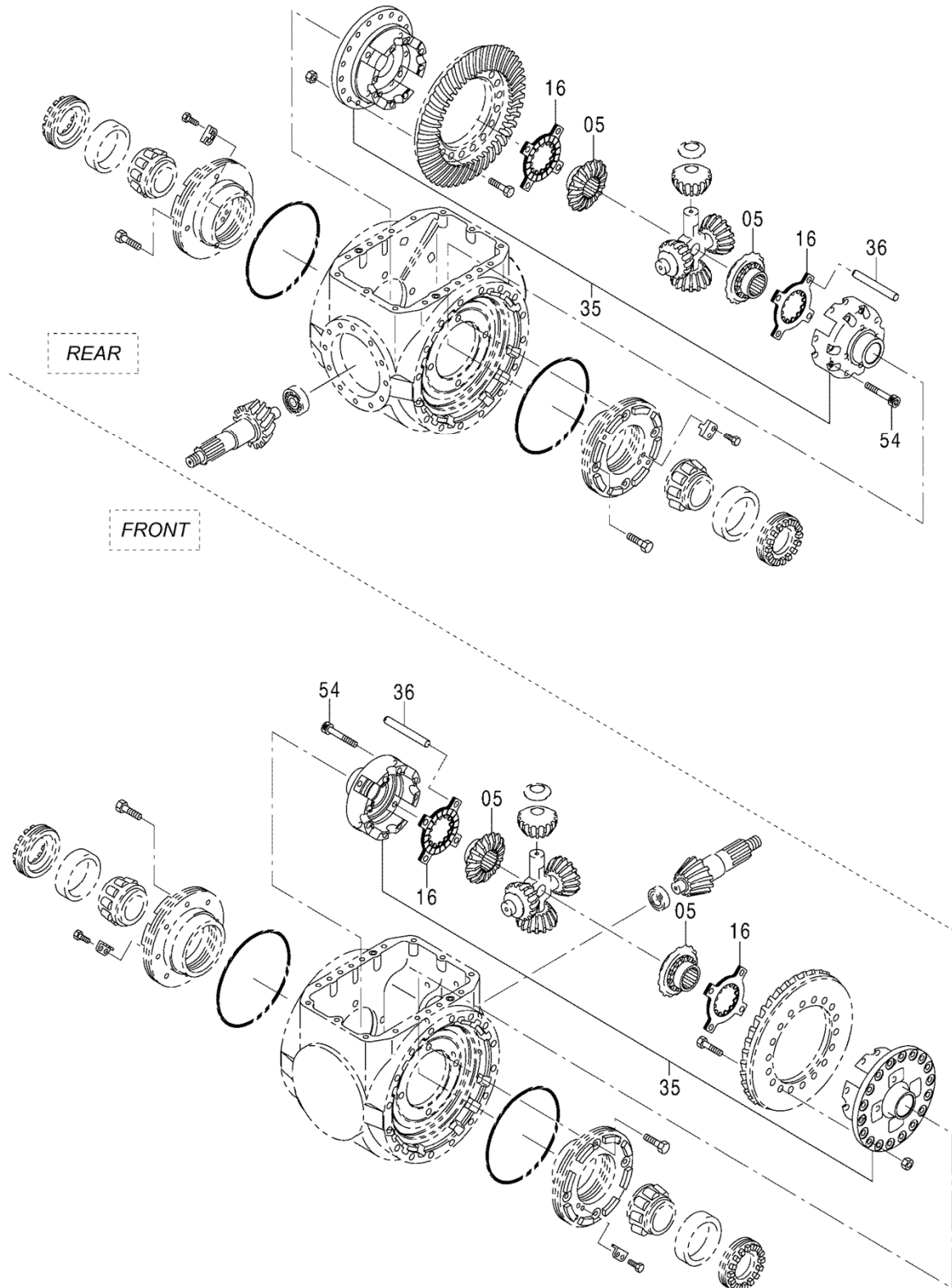

DCEYA00013230

ACCUMULATOR (PARKING BRAKE)
アキュムレータ (駐車ブレーキ)

Applicable Model (適用機種): -

Mark (記号): -

Serial No. (適用号機): -

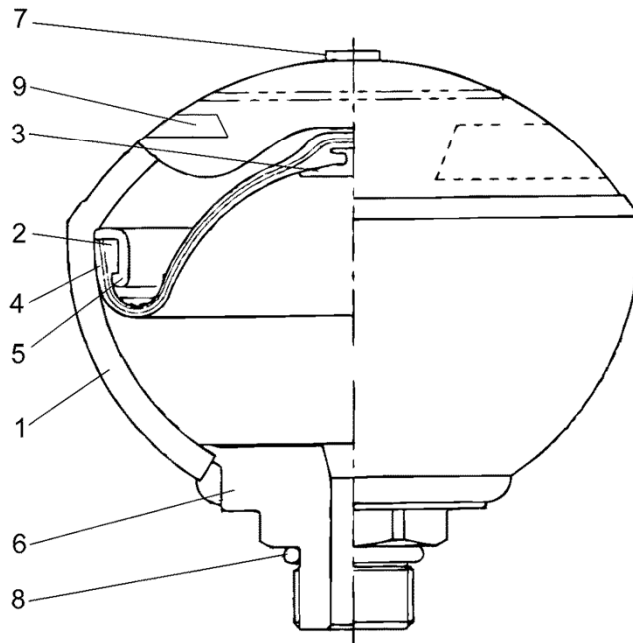

CLICK HERE TO **DOWNLOAD** THE COMPLETE MANUAL

- Thank you very much for reading the preview of the manual.
- You can download the complete manual from: www.heydownloads.com by clicking the link below



- Please note: If there is no response to CLICKING the link, please download this PDF first and then click on it.

CLICK HERE TO **DOWNLOAD** THE COMPLETE MANUAL