

## **R 1405 S / R 1405 SB / R 1425 S**

**Schwader / Rake / Andaineur**



**Ersatzteilliste**

**Spare parts list**

**Liste de pièces de rechange**

Gültig ab: / Valid from: / Valable à partir de:  
**P1350\_09RE01-DE-EN-FR.pdf**

ab Maschinen Nr.: / Serial No.: / No. de serie:  
**6122630-**

Ausgabe: / Edition: / Edition:  
**2009/01**

**1637860-DE-EN-FR**

**P 1350-ET**

Notieren Sie die Fabrikationsnummer Ihrer Maschine auf der Innenseite des Umschlages. / Please note the serial number of your machine at the inside of the cover. / Veuillez noter le numero de Votre machine sur la face interne de la couverture.

CLICK HERE TO **DOWNLOAD** THE COMPLETE MANUAL

- Thank you very much for reading the preview of the manual.
- You can download the complete manual from: [www.heydownloads.com](http://www.heydownloads.com) by clicking the link below



- Please note: If there is no response to CLICKING the link, please download this PDF first and then click on it.

CLICK HERE TO **DOWNLOAD** THE COMPLETE MANUAL



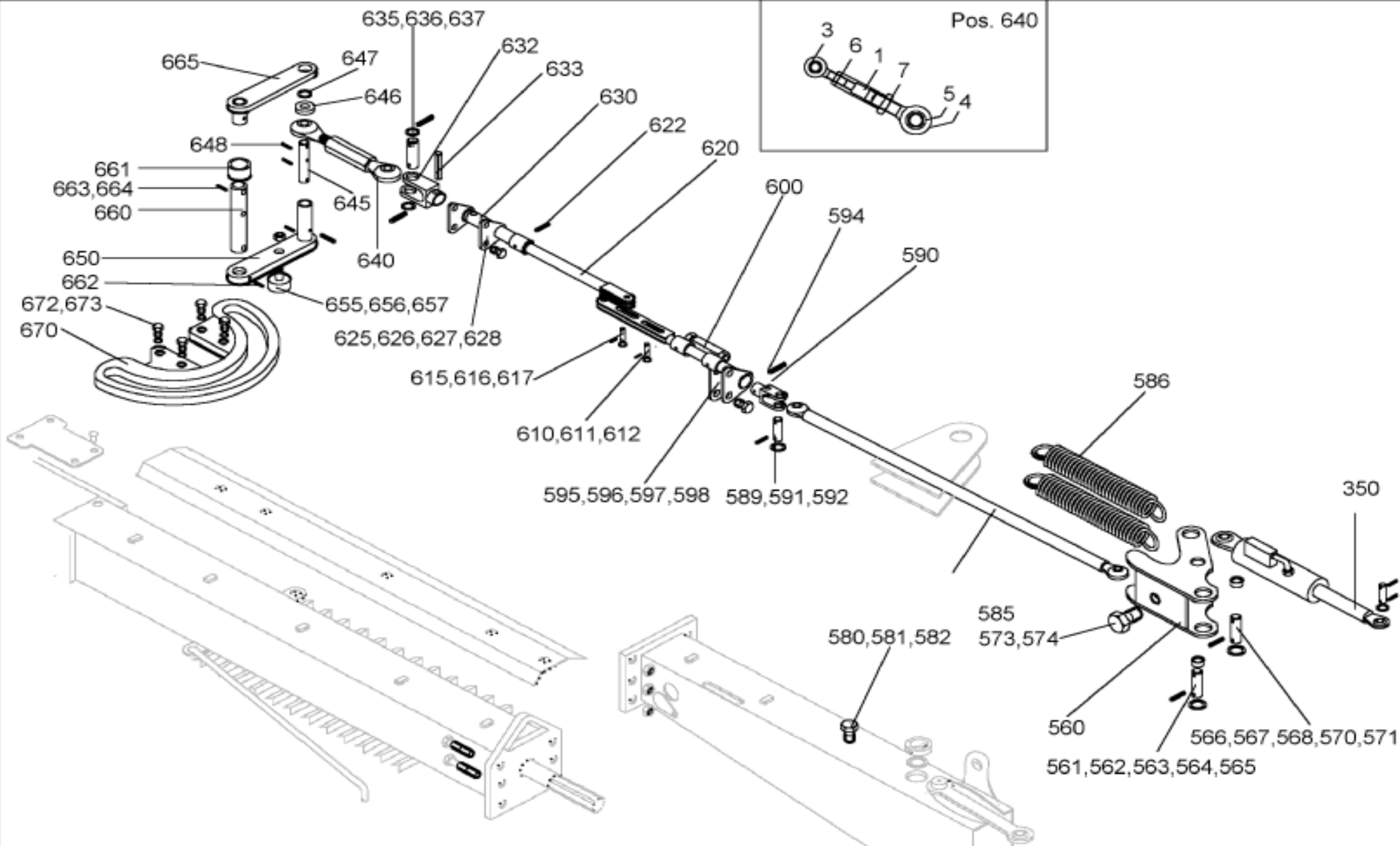

Antriebseinheit vo. Antriebseinheit hi.

P1350-5

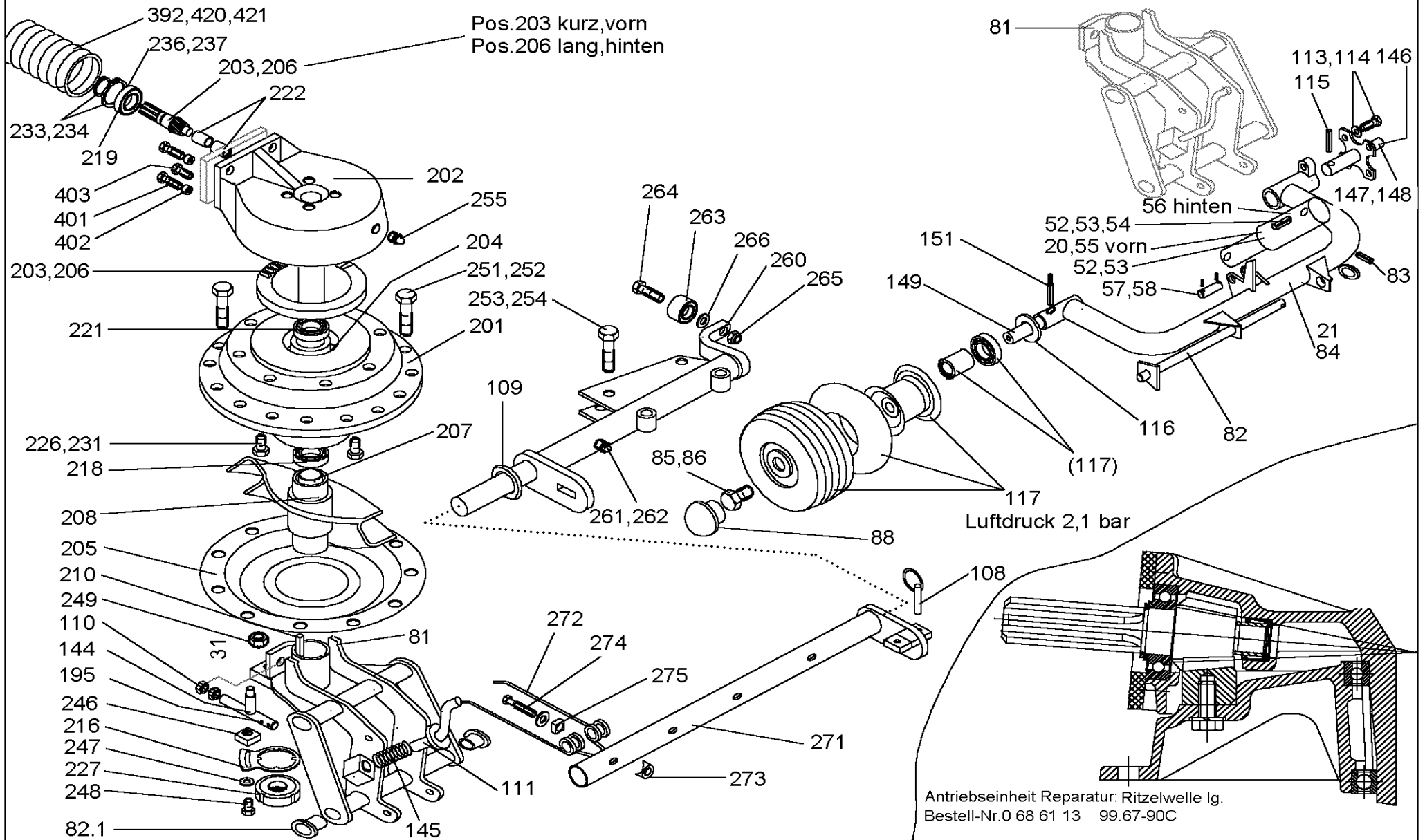







CLICK HERE TO **DOWNLOAD** THE COMPLETE MANUAL

- Thank you very much for reading the preview of the manual.
- You can download the complete manual from: [www.heydownloads.com](http://www.heydownloads.com) by clicking the link below



- Please note: If there is no response to CLICKING the link, please download this PDF first and then click on it.

CLICK HERE TO **DOWNLOAD** THE COMPLETE MANUAL