

Directions for use of Parts Catalogue

1. Applicable model of machines

All component and option parts used for SG13 lawn & garden tractorst ractors are listed in this parts catalogue.

Description of type of machines and particulars

TYPE Of Machines	Section	DESTINATION	Engine	
			E255 - G	E255 - G01
SG13	48	JAPAN	○	
	48E20	GERMANY	○	
	48E20S	GERMANY		○
	48E40	U.K	○	
	48E40S	U.K		○
	48E50	FRANCE	○	
	48E50T	ITALY	○	
	48R	JAPAN	○	

2. Explanation for head paragraph

KEY	PART CODE	DESCRIPTION	QTY	TYPE OF MODEL					I T C	C O L	G R P	REMARKS
				TF15	TF17	TF19						
126	1614-508-200-00	FILTER(SUCTION) ASSY	1		*						4E	
127	V721-103-103-50	O-RING	1		*							
128	1614-508-260-00	FILTER(SUCTION) ASSY	1		*	981- -1799						
129	1614-508-262-00	FILTER(LH)	1	*	*	*						FIG. 164
		ASSY	1	*	*	*					4E	A
			1	*	*	*			3			
						I- -1999						

①

②

③

④

⑤

⑥

⑦

⑧

⑨

⑩

- ① KEY shows the location of parts diagramed in the illustration.
- ② Parts numbers begin with `V` and `W` are standard parts of the market.
- ③ `LH` and `RH` on the parts name are described against the moving direction of the machine or are described on the condition how to install parts on the machines.

CLICK HERE TO **DOWNLOAD** THE COMPLETE MANUAL

- Thank you very much for reading the preview of the manual.
- You can download the complete manual from: www.heydownloads.com by clicking the link below



- Please note: If there is no response to CLICKING the link, please download this PDF first and then click on it.

CLICK HERE TO **DOWNLOAD** THE COMPLETE MANUAL

ENGINE

E255-G...SG13

FIG. 9 TIMING GEAR CASE

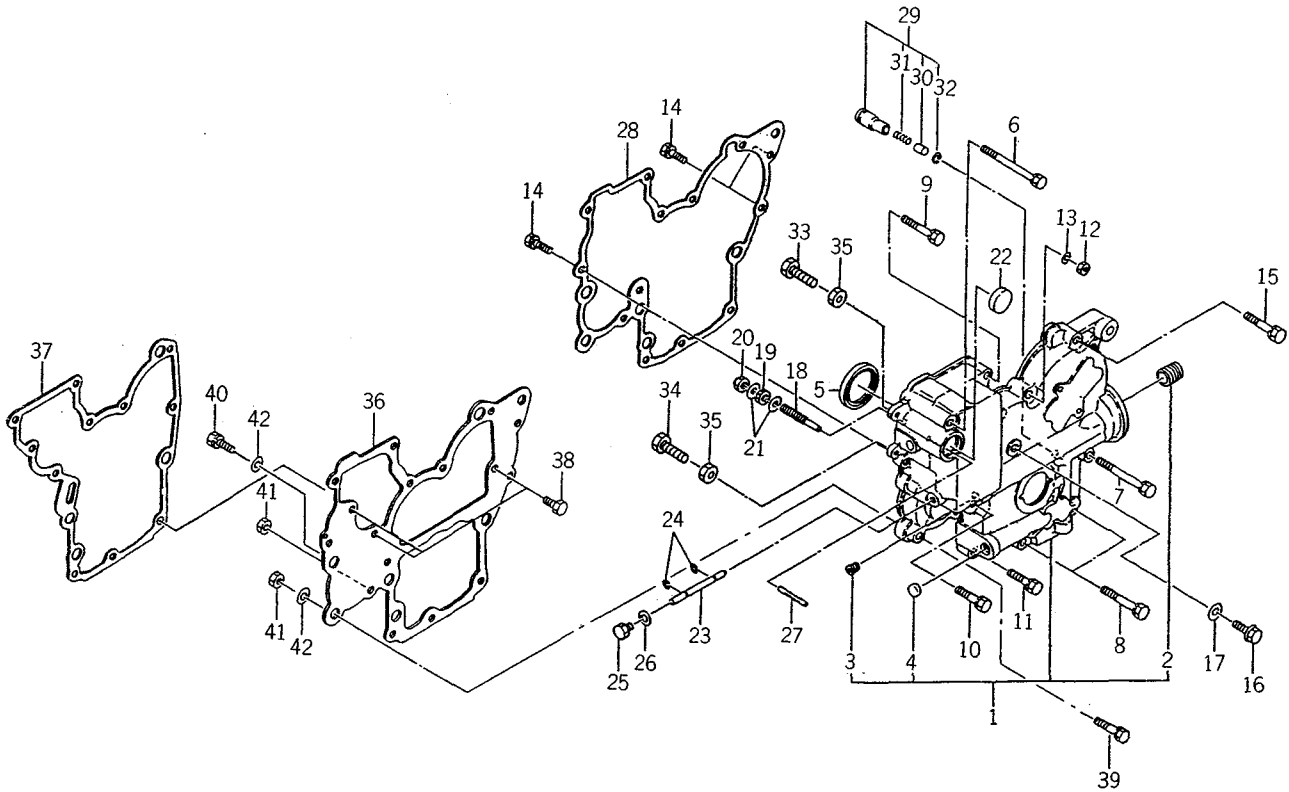

6003-240C

KEY	PART CODE	DESCRIPTION	QTY	TYPE OF MODEL		I T C	C O L	G R P	REMARKS
				E255G					
1	6211 - 310 - 006 - 20	GEARCASE ASSY	1	*					
2	6213 - 319 - 001 - 00	CONNECTOR,OIL FILTER	1	*					
3	6509 - 605 - 019 - 10	PLUG	3	*					
4	6209 - 610 - 002 - 10	CUP/SEALING/16	1	*					
5	6209 - 625 - 002 - 00	SEAL,OIL	1	*					
6	6209 - 030 - 005 - 00	BOLT/M8X85	1	*					
7	6209 - 030 - 006 - 00	BOLT/M8X75	1	*					
8	6509 - 000 - 084 - 00	BOLT/L = 55	2	*					
9	6509 - 030 - 037 - 00	BOLT	2	*					
10	6901 - 910 - 840 - 00	BOLT	1	*					
11	6901 - 910 - 835 - 00	BOLT,SEMS/M8X35	1	*					
12	6909 - 110 - 508 - 00	NUT/M8	1	*					
13	6909 - 150 - 508 - 00	WASHER	1	*					
14	V211 - 560 - 802 - 00	BOLT/M8X20	3	*					
15	6901 - 910 - 845 - 00	BOLT,SEMS/M8X45	1	*					
16	6209 - 046 - 001 - 00	BOLT/M8X30	1	*					
17	6909 - 920 - 843 - 00	PACKING	1	*					
18	6215 - 546 - 001 - 00	STOPPER,FULL - LOAD	1	*					
19	6209 - 409 - 001 - 00	NUT/M8	1	*					
20	V341 - 120 - 008 - 00	NUT,CAP/M 8	1	*					
21	6909 - 920 - 843 - 00	PACKING	2	*					
22	3625 - 540 - 004 - 00	CAP,BLANK/30	1	*					
23	6215 - 542 - 001 - 10	PIN/ARM	1	*					
24	V710 - 140 - 004 - 00	RING,SNAP/ 4 E	2	*					
25	6909 - 202 - 308 - 00	PLUG	1	*					

FIG. 26 6215 - 600 - 057 - 00

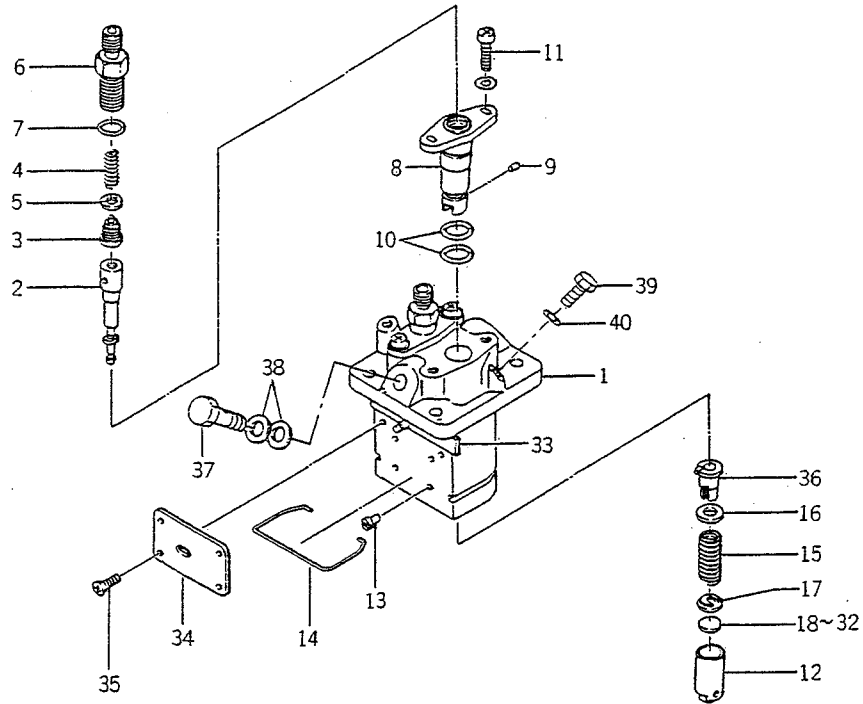

6003-510F

KEY	PART CODE	DESCRIPTION	QTY	TYPE OF MODEL		I T C	C O L	G R P	REMARKS
				E255G					
1	6215 - 611 - 003 - 00	HOUSING PUMP	1	*					
2	6215 - 631 - 004 - 00	PLUNGER ASSY	2	*					
3	6215 - 641 - 002 - 00	VALVE, DELIVERY	2	*					
4	6215 - 643 - 003 - 00	SPRING, DELIVERY VALVE	2	*					
5	6215 - 649 - 003 - 00	GASKET	2	*					
6	6215 - 644 - 003 - 00	HOLDER, DELIVERY VALVE	2	*					
7	6215 - 649 - 004 - 00	O - RING	2	*					
8	6215 - 635 - 002 - 00	SLEEVE, FRANGE	2	*					
9	6215 - 649 - 005 - 00	PIN	2	*					
10	6215 - 649 - 006 - 00	O - RING	4	*					
11	6215 - 649 - 007 - 00	SCREW	4	*					
12	6215 - 622 - 002 - 00	TAPPET	2	*					
13	6215 - 629 - 017 - 00	PIN	2	*					
14	6215 - 629 - 019 - 00	RING SNAP	1	*					
15	6215 - 634 - 002 - 00	SPRING, PLUNGER	2	*					
16	6215 - 639 - 006 - 00	SEAT, SPRING	2	*					
17	6215 - 639 - 007 - 00	SEAT, SPRING	2	*					
18	6215 - 629 - 020 - 00	PLATE / T = 1.80	1	*					
19	6215 - 629 - 021 - 00	PLATE / T = 1.85	1	*					
20	6215 - 629 - 022 - 00	PLATE / T = 1.90	1	*					
21	6215 - 629 - 023 - 00	PLATE / T = 1.95	1	*					
22	6215 - 629 - 024 - 00	PLATE / T = 2.00	1	*					
23	6215 - 629 - 025 - 00	PLATE / T = 2.05	1	*					
24	6215 - 629 - 026 - 00	PLATE / T = 2.10	1	*					
25	6215 - 629 - 027 - 00	PLATE / T = 2.15	1	*					

CLICK HERE TO **DOWNLOAD** THE COMPLETE MANUAL

- Thank you very much for reading the preview of the manual.
- You can download the complete manual from: www.heydownloads.com by clicking the link below



- Please note: If there is no response to CLICKING the link, please download this PDF first and then click on it.

CLICK HERE TO **DOWNLOAD** THE COMPLETE MANUAL

FIG. 28 LINK and LIFT SYSTEM

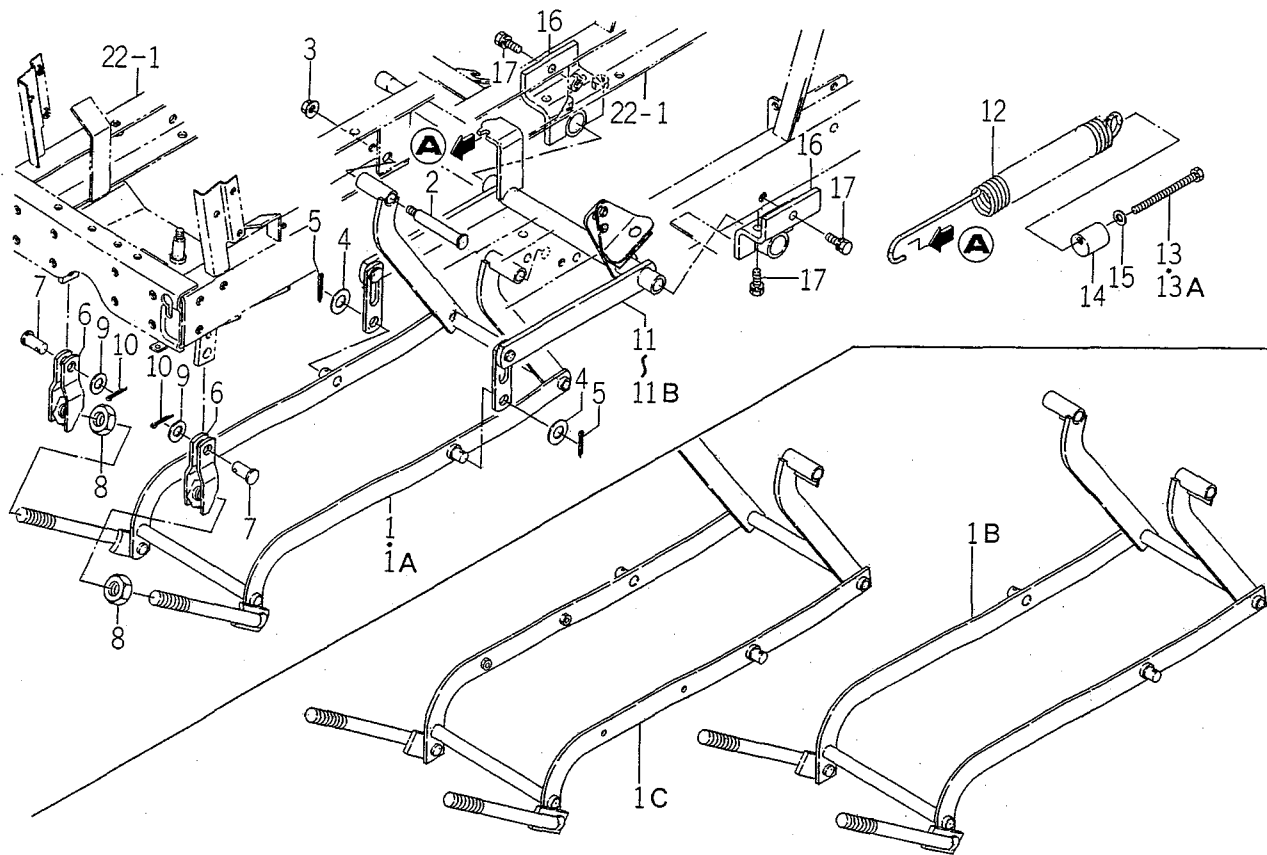

1593-553

KEY	PART CODE	DESCRIPTION	QTY	TYPE OF MODEL		I T C	C O L	G R P	REMARKS
				SG13					
1	1593 - 553 - 540 - 20	LINK	1	1-					
1A	1593 - 553 - 540 - 30	LINK	1	-80					
1B	1593 - 553 - 540 - 40	LINK	1	81-					
1C	1593 - 553 - 540 - 50	LINK	1	-166					
2	1593 - 553 - 003 - 20	PIN/15X108	2	167-					
3	V363 - 260 - 010 - 00	NUT/M10	2	-366					
4	V411 - 260 - 014 - 00	WASHER,PL/M14	2	367-					
5	V500 - 163 - 002 - 50	PIN,SPLIT/3 X25	2	*					
6	1593 - 553 - 550 - 10	LINK/A	2	*					
7	1593 - 553 - 007 - 20	PIN/15X32	2	*					
8	V305 - 260 - 020 - 00	NUT/M20	2	*					
9	V411 - 260 - 014 - 00	WASHER,PL/M14	2	*					
10	V500 - 163 - 002 - 50	PIN,SPLIT/3 X25	2	*					
11	1593 - 553 - 500 - 40	LIFT/270	1	1-					
11A	1593 - 553 - 500 - 50	LIFT/270	1	-166					
11B	1593 - 553 - 500 - 60	LIFT/270 COMP	1	167-					
12	1593 - 553 - 054 - 10	SPRING/HE450	1	-366					
13	1593 - 553 - 012 - 00	BOLT/M10X120	1	367-					
13A	1593 - 553 - 012 - 10	BOLT/M10X120	1	*					
14	1593 - 553 - 006 - 10	HOOK,SPRING/D = 32	1	*					
15	V411 - 260 - 010 - 00	WASHER/M10	1	1-					
16	1593 - 553 - 670 - 30	METAL,LIFTARM	2	-295					
17	V211 - 561 - 002 - 50	BOLT/M10X25	6	296-					

NUMERICAL INDEX

6003-096-100-00

PART CODE	FIG. KEY	PART CODE	FIG. KEY	PART CODE	FIG. KEY
J061-210-015-00	17 23	6209-360-028-10	2 6	6211-360-004-10	7 1
J062-062-067-00	21 6	6209-409-001-00	9 19	6211-361-019-10	7 2
J062-076-082-00	21 5	6209-409-003-00	11 18	6211-510-002-00	5 10
V211-560-802-00	3 3	6209-490-002-00	2 4	6211-511-003-00	5 11
	9 14	6209-500-003-00	9 17A	6211-511-004-00	5 12
	17 19	6209-580-002-10	20 37	6211-540-002-00	6 1
	17 27	6209-587-001-00	13 4	6211-560-002-00	6 3
	22 4	6209-600-002-00	7 3	6211-599-001-10	5 13
V211-560-802-50	4 3	6209-605-004-00	1 4		6 2
	9 40	6209-610-001-00	5 3		6 4
V341-120-008-00	9 20	6209-610-002-10	9 4	6211-715-002-00	1 5
V411-260-006-00	20 41	6209-623-001-00	7 4	6211-721-001-00	1 6
V600-110-600-40	20 12	6209-625-001-00	5 14	6211-721-002-00	1 7
V600-110-620-30	20 11		24 10	6211-751-001-10	2 2
V682-200-000-60	1 9	6209-625-002-00	9 5	6211-760-003-10	5 29
V704-140-016-00	11 16		24 12	6211-777-007-20	10 1
V705-140-012-00	9 32	6209-630-002-10	23 6	6212-111-009-00	13 1
V710-140-004-00	9 24		24 21	6212-114-009-00	14 1
	20 21	6209-740-001-00	9 27	6212-116-009-00	14 3
	20 31	6209-749-001-10	5 15	6212-121-004-00	13 2
V720-101-900-80	20 36	6209-788-001-00	5 27	6212-124-004-00	14 2
V720-102-401-50	16 9	6209-940-004-00	11 15	6212-126-004-00	14 4
	24 16	6211-110-017-20	1 1	6212-211-001-10	13 3
V723-102-005-50	17 31	6211-141-010-20	1 10	6212-230-003-00	13 5
	24 20		24 3	6212-235-001-00	13 6
1373-121-001-00	22 5	6211-150-006-00	1 2	6212-261-006-00	13 8
3625-540-004-00	9 22	6211-170-006-10	2 1	6212-264-006-00	6 5
6209-000-002-00	11 19	6211-173-004-00	2 3	6212-266-006-00	6 6
6209-000-003-00	1 11		24 4	6212-310-010-00	15 1
6209-000-004-00	5 2	6211-210-020-10	5 1	6212-310-010-10	15 1A
6209-000-004-10	5 2A	6211-258-001-00	5 8	6212-330-013-30	15 5
6209-000-013-00	15 7		24 8	6212-333-001-00	15 6
6209-009-001-00	16 6	6211-258-002-00	5 9	6212-371-014-20	15 8
6209-030-005-00	9 6		24 9	6212-379-001-00	15 9
6209-030-006-00	9 7	6211-291-001-10	5 23	6212-511-004-00	12 1
	17 28	6211-292-001-20	5 24	6212-521-002-00	15 3
6209-030-041-00	18 4		24 11	6212-522-003-00	12 2
6209-030-043-00	20 16	6211-310-006-20	9 1	6212-523-003-00	12 6
6209-044-001-00	20 34	6211-311-005-10	9 36	6212-524-002-00	20 9
6209-046-001-00	9 16	6211-312-001-20	9 28	6212-531-005-10	5 6
6209-050-001-00	9 33		24 14	6212-535-001-00	12 4
6209-050-002-00	9 34	6211-312-002-20	9 37	6212-535-002-00	20 13
6209-056-001-00	20 7		24 15	6212-551-001-00	11 1
6209-300-002-00	17 18	6211-340-001-30	8 1	6212-552-001-00	11 2
6209-360-010-00	21 2	6211-342-001-30	8 2	6212-561-001-00	11 3

CLICK HERE TO **DOWNLOAD** THE COMPLETE MANUAL

- Thank you very much for reading the preview of the manual.
- You can download the complete manual from: www.heydownloads.com by clicking the link below



- Please note: If there is no response to CLICKING the link, please download this PDF first and then click on it.

CLICK HERE TO **DOWNLOAD** THE COMPLETE MANUAL