



PARTS CATALOGUE NEWS

Honda Motor Co., Ltd. Service Division

PARTS CATALOGUE - CORRECTED

Printed in Japan

CODE NO.	BOOKLET TYPE	13Z1V401
	MICRO-FICHE	13Z1V4EA/FA
PARTS CATALOGUE NEWS	GXV160H2	
NEWS NO.	001	

Block No.	Ref. No.	Note	Part No.	Description	Reqd. QTY GXV 160 HZ	Serial No.	Parts catalogue code
-----------	----------	------	----------	-------------	-------------------------------	------------	----------------------

E-19-1 FLYWHEEL (2)

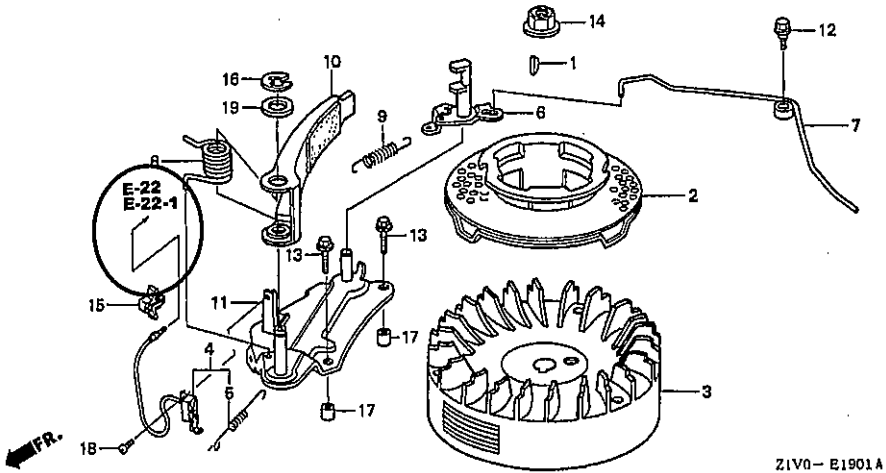

Z1V0-E1901A

E-19-1	15	E	90649-ZG9-T41	*PARTS NO. DELETION
--------	----	---	---------------	---------------------

NOTE A:PART NO. CHANGE D:NEWLY PROVIDED E:PART NO. DELETION K:REQUIRED NO. CORRECTION L:APPLICATION SERIAL NO. CORRECTION
T:APPLICATION CORRECTION Z:REMARKS CHANGE

CLICK HERE TO **DOWNLOAD** THE COMPLETE MANUAL

- Thank you very much for reading the preview of the manual.
- You can download the complete manual from: www.heydownloads.com by clicking the link below



- Please note: If there is no response to CLICKING the link, please download this PDF first and then click on it.

CLICK HERE TO **DOWNLOAD** THE COMPLETE MANUAL



PARTS CATALOGUE NEWS

Honda Motor Co., Ltd. Service Division

PARTS CATALOGUE - CORRECTED

Printed in Japan

CODE NO.	BOOKLET TYPE	13Z1V401
	MICRO-FICHE	13Z1V4EA/FA
PARTS CATALOGUE NEWS	GXV160H2	
NEWS NO.	005	

Block No.	Ref. No.	Note	Part No.	Description	Reqd. QTY	Serial No.	Parts catalogue code
					GXV 160 H2		
E-12	4	E	90581-GB5-610	*PARTS NO. DELETION			
		D	90581-Z1V-000	WASHER, PLAIN, 6MM	2		

NOTE A: PART NO. CHANGE D: NEWLY PROVIDED E: PART NO. DELETION K: REQUIRED NO. CORRECTION L: APPLICATION SERIAL NO. CORRECTION
T: APPLICATION CORRECTION Z: REMARKS CHANGE



PARTS CATALOGUE NEWS

Honda Motor Co., Ltd. Service Division

PARTS CATALOGUE - CORRECTED

Printed in Japan

CODE NO.	BOOKLET TYPE	13Z1V401
	MICRO-FICHE	13Z1V4EA/FA
PARTS CATALOGUE NEWS	GXV160H2	
NEWS NO.	009	

Block No.	Ref. No.	Note	Part No.	Description	Reqd. QTY	Serial No.	Parts catalogue code
					GXV 160 H2		
E-11	1	D	28400-ZE7-V11ZB	STARTER ASSY., RECOIL (LONG)	1	-----	N1F
				NH1.....BLACK			
	T	28400-ZE7-003ZB	STARTER ASSY., RECOIL	1	-----	A14, SFL1, T1AH	
	2	T	28410-ZE7-003ZB	CASE COMP., RECOIL STARTER	1	-----	A14, N1F, SFL1, T1AH
				NH1.....BLACK			
E-12	1	T	19610-Z1V-000ZB	COVER COMP., FAN	1	-----	A14, N1F, SFL1, T1AH
				NH1.....BLACK			

NOTE A:PART NO.CHANGE D:NEWLY PROVIDED E:PART NO.DELETION K:REQUIRED NO.CORRECTION L:APPLICATION SERIAL NO.CORRECTION
T:APPLICATION CORRECTION Z:REMARKS CHANGE

PARTS CATALOGUE NEWS

BOOKNo. :13Z1V401

Block No.	Ref. No.	Part No.	Description	Reqd. QTY 0XV 160 H2	Base Part No.	Parts catalogue code
		28400-Z1V-J51ZA	STARTER ASSY., RECOIL (LONG, HEPE)		28400-ZE7-V11ZB	
			R280.....POWER RED	1		A1SA, N5M
		28400-Z1V-J51ZA	*R280*.....POWER RED	1	28400-ZE7-003ZB	A1S
		28400-Z1V-J51ZA	*R280*.....POWER RED	1	28400-ZE7-003ZC	N15, N45, N55
		28400-Z1V-J51ZB	STARTER ASSY., RECOIL (LONG)			
			NH1.....BLACK	1		N15, N45, N55
		28400-Z1V-J51ZB	*NH1*.....BLACK	1	28400-ZE7-V11ZC	A1SA, N5M
		28400-Z1V-J51ZB	*NH1*.....BLACK	1	28400-ZE7-003ZC	A1S
	2		CASE COMP., RECOIL STARTER		28410-ZE7-003ZB	
			NH1.....BLACK	0		C14
		28410-ZE7-003ZB	*NH1*.....BLACK	1		N15, N45, N55
	9	28461-ZE7-T00	GRIP, STARTER	1	28461-ZE1-003	A1S, A1SA, N5M
	10	28462-ZE7-V11	ROPE, RECOIL STARTER	1	28462-ZA7-003	A1S, N15, N45, N55
E-12	1		COVER COMP., FAN		19610-Z1V-000ZB	
			NH1.....BLACK	0		C14
		19610-Z1V-000ZB	*NH1*.....BLACK	1		N15, N45, N55
E-14	9	16100-Z1V-J71	CARBURETOR ASSY. (BE66M A) ...	1	16100-Z1V-003	N5M
	11	16166-Z1V-J71	NOZZLE, MAIN	1	16166-Z1V-003	N5M
	21	99101-ZH8-0650	JET, MAIN, #65	(1)	99101-ZH8-0600	N5M
		99101-ZH8-0680	JET, MAIN, #68	1	99101-ZH8-0650	N5M
E-16	2	18292-ZE7-M10	PACKING, PROTECTOR	2		N15, N45, N55, SFY
E-17	2	16952-Z1V-000	STRAINER, FUEL	1	16952-ZA8-800	
E-19	1		KEY, SPECIAL WOODRUFF, 25X18 .	0	13331-357-000	A1SA
	2		FAN, COOLING	0	19511-Z1T-000	A1SA
	3		PULLEY COMP., STARTER	0	28451-ZE7-003	A1SA
	4		FLYWHEEL COMP.	0	31110-Z1V-003	A1SA

NOTE A:PART NO.CHANGE D:NEWLY PROVIDED E:PART NO.DELETION K:REQUIRED NO.CORRECTION L:APPLICATION SERIAL NO.CORRECTION
T:APPLICATION CORRECTION Z:REMARKS CHANGE



PARTS CATALOGUE NEWS

Honda Motor Co., Ltd. Service Division

PARTS CATALOGUE - CORRECTED

Printed in Japan

CODE NO.	BOOKLET TYPE	13Z1V401
	MICRO-FICHE	13Z1V4EA/FA
PARTS CATALOGUE NEWS	GXV160H2	
NEWS NO.	013	

Block No.	Ref. No.	Note	Part No.	Description	Reqd. QTY	Serial No.	Parts catalogue code
					GXV 160 H2		
E-3	22	E	17517-ZE7-000	*PARTS NO. DELETION			
E-22	17	T	36103-ZE1-000	HOLDER, STOP SWITCH CORD	1	-----	N1, N4, N5, N5M, N6, SFL, SFL1, SFY, SFY1, T1AH
E-22-1	16	T	36103-ZE1-000	HOLDER, STOP SWITCH CORD	1	-----	N1F, N15, N45, N55

NOTE A:PART NO.CHANGE D:NEWLY PROVIDED E:PART NO.DELETION K:REQUIRED NO.CORRECTION L:APPLICATION SERIAL NO.CORRECTION
T:APPLICATION CORRECTION Z:REMARKS CHANGE

CLICK HERE TO **DOWNLOAD** THE COMPLETE MANUAL

- Thank you very much for reading the preview of the manual.
- You can download the complete manual from: www.heydownloads.com by clicking the link below



- Please note: If there is no response to CLICKING the link, please download this PDF first and then click on it.

CLICK HERE TO **DOWNLOAD** THE COMPLETE MANUAL