

Genie®

GTH-3713

CATALOGO PARTI DI RICAMBIO
SPARE PARTS CATALOGUE
CATALOQUE DE PIECES DETACHEES
ERSATZTEILKATALOG
CATALOGO DE PIEZAS DE REPUESTO

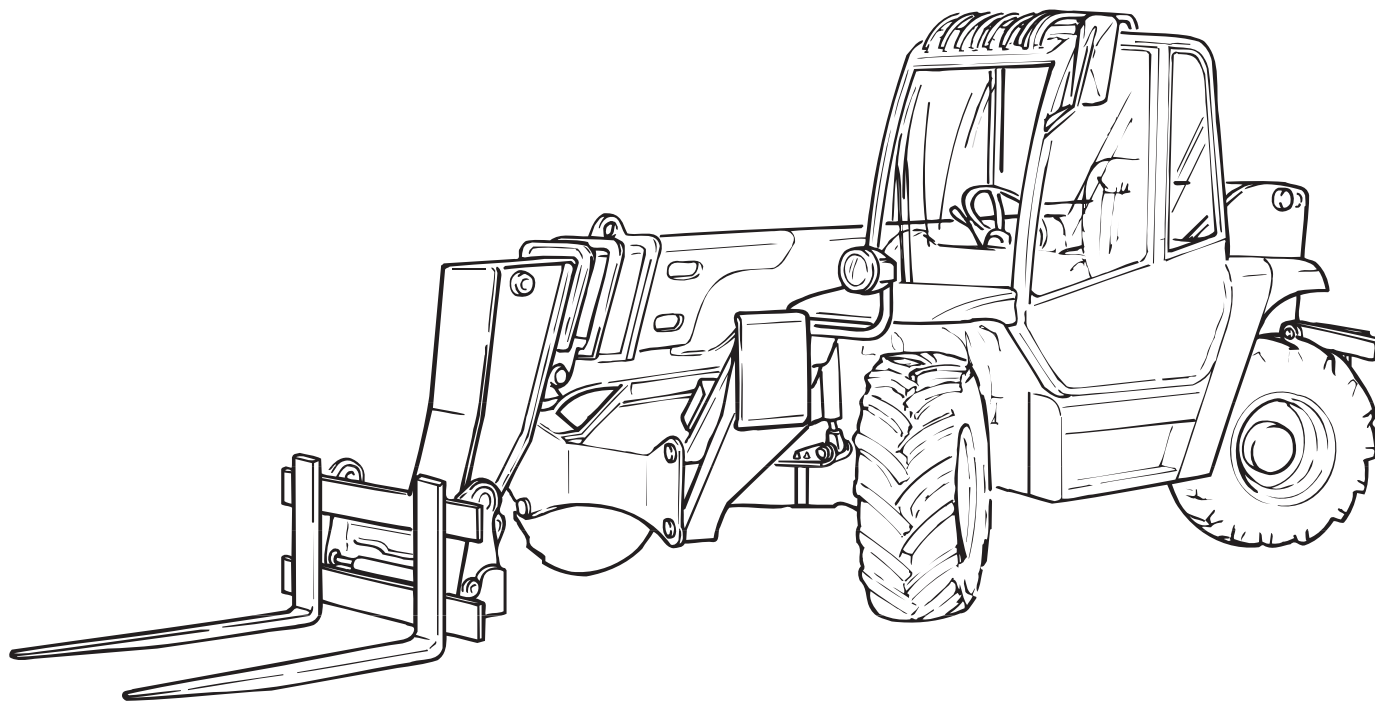

CR 57.0404.6000

Rev. 1 11/2004

Matr.

CLICK HERE TO **DOWNLOAD** THE COMPLETE MANUAL

- Thank you very much for reading the preview of the manual.
- You can download the complete manual from: www.heydownloads.com by clicking the link below



- Please note: If there is no response to CLICKING the link, please download this PDF first and then click on it.

CLICK HERE TO **DOWNLOAD** THE COMPLETE MANUAL

**ELENCO TAVOLE REVISIONATE - LIST OF REVISED TABLES - LISTE DES TABLEAUX REVISE
LISTE ÜBERARBEITETE TAFELN - LISTA TABLAS REVISADAS**

N°	Data	Tavole interessate - Tables involved - Tableaux impliqués - Überarbeitete Tafeln - Tablas implicadas	Note
1	11/2004	AG: 604012-0, 604013-0, 604014-0, 604015-0, 604016-0, 604017-0, 604018-0, 604019-0, 604020-0, 604021-0, 604022-0, 604023-0, 604024-0.	
		EL: 602950-0, 602951-1, 602954-1, 602956-1, 603100-0, 603101-1, 603103-0, 603104-0, 603375-0, 603377-0, 603378-0, 603659-0.	
		RV: 602754-3, 603071-6, 603090-3, 603655-1, 603656-1, 603657-1.	
2			
3			
4			
5			
6			
7			
8			
9			
10			
11			
12			
13			
14			
15			
16			
17			

Legenda - Key - Légende - Erläuterungen - Leyenda:

AG: tavole aggiunte - added tables - tableaux ajoutés - hinzugefügte Tafeln - tablas añadidas.

EL: tavole eliminate - cancelled tables - tableaux éliminés - gestrichene Tafeln - tablas eliminadas.

RV: tavole revisionate - revised tables - tableaux révisés - geänderte Tafeln - tablas revisadas.

6

GRUPPO MATERIALE ELETTRICO

ELECTRIC INSTALLATION UNIT
GROUPE INSTALLATION ELECTRIQUE
ELEKTROANLAGE-AGGREGAT
GRUPO INSTALACION ELECTRICA

603379 - 1

MOTORE DIESEL - IMPIANTO DI SCARICO (TURBO)

DIESEL ENGINE - EXHAUST SYSTEM
MOTEUR DIESEL - SYSTEME DECHARGE
DIESELMOTOR - MOTOR ABLASS
MOTOR DIESEL - SISTEMA DESCARGA

603385 - 2

MOTORE DIESEL - ACCELERATORE (TURBO)

DIESEL ENGINE - ACCELERATOR
MOTEUR DIESEL - ACCELERATEUR
DIESELMOTOR - BESCHLEUNIGER
MOTOR DIESEL - ACELERADOR

603386 - 1

MOTORE DIESEL - IMPIANTO DI ASPIRAZIONE (TURBO)

DIESEL ENGINE - INJECTION SYSTEM
MOTEUR DIESEL - SYSTEME D'ASPIRATION
DIESELMOTOR - SAUGANLAGE
MOTOR DIESEL - SISTEMA DE ASPIRACIÓN

603071 - 6

MATERIALE ELETTRICO

ELECTRIC INSTALLATION
INSTALLATION ELECTRIQUE
ELEKTROANLAGE
INSTALACION ELECTRICA

603660 - 0

SCATOLA PORTAFUSIBILI

FUSE HOLDING BOX
BOITE PORTE FUSIBLES
SICHERUNGSGEHÄUSE
CAJA DE FUSIBLES

POS.	CODICE	Q.tà	DENOMINAZIONE	DESCRIPTION	DESIGNATION	BENENNUNG	DENOMINACIONES	NOTE		
								A	B	C
1	07.0712.0025	1	RADIATORE	OIL COOLER	RADIATEUR	STRAHLER	RADIADOR			
2	07.0712.0026	1	CONVOGLIATORE	CONVEYOR	CONVOYEUR	FOERDERER	TRASPORTADOR			
3	07.0712.0010	1	VENTOLA	FAN	HELICE VENTILATION	PROPELLER	RUEDA DE ALETAS			
4	07.0712.0028	1	GRIGLIATO	GRATE	GRILLAGE	GITTERROST	ENREJADO			
5	07.0712.0027	1	GIUNTO	JOINT	JOINT	KUPPLUNG	JUNTA			
6	07.0712.0005	1	SUPPORTO	SUPPORT	SUPPORT	LAGER	SOPORTE			
7	53.3200.0009	1	RADIATORE COMPLETO	COMPLETE RADIATOR	RADIATEUR COMPLET	KÜHLER KOMPLETT	RADIADOR COMPLETO			
8	04.4235.0015	1	MOTORE IDRAULICO	HYDRAULIC MOTOR	MOTEUR HYDRAULIQUE	HYDRAULIKMOTOR	MOTOR HIDRAULICO			
9	04.4225.0001	1	VALVOLA	VALVE	SOUPAPE	VENTIL	VALVULA			
10	04.4223.0002	1	RACCORDO	PIPE FITTING	RACCORD DE TUYAU	ROHRVERBINDUNG	CONEXIÓN			
11	900035	1	GUARNIZIONE O.R.	SEAL	JOINT	DICHTUNG	GUARNICIÓN			
12	04.0601.0004	1	RACCORDO	PIPE FITTING	RACCORD DE TUYAU	ROHRVERBINDUNG	CONEXIÓN			
13	04.0603.0037	1	TUBO FLESSIBILE	FLEXIBLE HOSE	TUYAU SOUPLE	SOUPLESCHLAUCH	TUBO FLEXIBLE			
14	04.0601.0028	1	RACCORDO	PIPE FITTING	RACCORD DE TUYAU	ROHRVERBINDUNG	CONEXIÓN			
15	04.0603.0040	1	TUBO FLESSIBILE	FLEXIBLE HOSE	TUYAU SOUPLE	SOUPLESCHLAUCH	TUBO FLEXIBLE			
16	04.4223.0001	1	RACCORDO	PIPE FITTING	RACCORD DE TUYAU	ROHRVERBINDUNG	CONEXIÓN			
17	04.0601.0022	1	RACCORDO	PIPE FITTING	RACCORD DE TUYAU	ROHRVERBINDUNG	CONEXIÓN			
18	04.0601.0014	1	RACCORDO	PIPE FITTING	RACCORD DE TUYAU	ROHRVERBINDUNG	CONEXIÓN			
19	04.0603.0044	2	TUBO FLESSIBILE	FLEXIBLE HOSE	TUYAU SOUPLE	SOUPLESCHLAUCH	TUBO FLEXIBLE			
20	04.0603.0045	1	TUBO FLESSIBILE	FLEXIBLE HOSE	TUYAU SOUPLE	SOUPLESCHLAUCH	TUBO FLEXIBLE			
21	04.0601.0015	1	RACCORDO	PIPE FITTING	RACCORD DE TUYAU	ROHRVERBINDUNG	CONEXIÓN			
22	04.0603.0049	1	TUBO FLESSIBILE	FLEXIBLE HOSE	TUYAU SOUPLE	SOUPLESCHLAUCH	TUBO FLEXIBLE			
23	04.0601.0001	1	RACCORDO	PIPE FITTING	RACCORD DE TUYAU	ROHRVERBINDUNG	CONEXIÓN			
24	04.0603.0043	1	TUBO FLESSIBILE	FLEXIBLE HOSE	TUYAU SOUPLE	SOUPLESCHLAUCH	TUBO FLEXIBLE			
25	04.0601.0001	1	RACCORDO	PIPE FITTING	RACCORD DE TUYAU	ROHRVERBINDUNG	CONEXIÓN			
26	04.0601.0037	1	RACCORDO	PIPE FITTING	RACCORD DE TUYAU	ROHRVERBINDUNG	CONEXIÓN			
27	04.0603.0033	1	TUBO FLESSIBILE	FLEXIBLE HOSE	TUYAU SOUPLE	SOUPLESCHLAUCH	TUBO FLEXIBLE			
28	04.0603.0035	1	TUBO FLESSIBILE	FLEXIBLE HOSE	TUYAU SOUPLE	SOUPLESCHLAUCH	TUBO FLEXIBLE			
29	04.0601.0026	1	RACCORDO	PIPE FITTING	RACCORD DE TUYAU	ROHRVERBINDUNG	CONEXIÓN			
30	04.0601.0022	1	RACCORDO	PIPE FITTING	RACCORD DE TUYAU	ROHRVERBINDUNG	CONEXIÓN			
31	04.0601.0027	1	RACCORDO	PIPE FITTING	RACCORD DE TUYAU	ROHRVERBINDUNG	CONEXIÓN			
32	04.4239.0009	1	VALVOLA	VALVE	SOUPAPE	VENTIL	VALVULA			
34	51.0800.4400	1	SUPPORTO	SUPPORT	SUPPORT	LAGER	SOPORTE			
35	09.0805.0009	1	GUARNIZIONE	SEAL	JOINT	DICHTUNG	GUARNICIÓN			
36	07.0712.0012	2	ANTIVIBRANTE	INSULATOR	PIECE ANTIVIBRATILE	SCHWINGUNGSDÄMPFER	ANTIVIBRADOR			

CLICK HERE TO **DOWNLOAD** THE COMPLETE MANUAL

- Thank you very much for reading the preview of the manual.
- You can download the complete manual from: www.heydownloads.com by clicking the link below



- Please note: If there is no response to CLICKING the link, please download this PDF first and then click on it.

CLICK HERE TO **DOWNLOAD** THE COMPLETE MANUAL

POS.	CODICE	Q.tà	DENOMINAZIONE	DESCRIPTION	DESIGNATION	BENENNUNG	DENOMINACIONES	NOTE		
								A	B	C
1	09.4601.0014	1	MOTORE TURBO	ENGINE	MOTEUR	MOTOR	MOTOR			
2	51.0800.1500	2	SUPPORTO	SUPPORT	SUPPORT	LAGER	SOPORTE			
3	51.0800.1600	2	SUPPORTO	SUPPORT	SUPPORT	LAGER	SOPORTE			
4	09.4670.0003	4	ANTIVIBRANTE	INSULATOR	PIECE ANTIVIBRATILE	SCHWINGUNGSDÄMPFER	ANTIVIBRADOR			
5	07.0713.0006	1	VITE	SCREW	VIS	SCHRAUBE	TORNILLO			
6	07.0713.0005	1	RONDELLA ELASTICA	SPRING WASHER	RONDELLE ELASTIQUE	FEDERSCHEIBE	ARANDELA ELASTICA			
7	07.0713.0007	1	RONDELLA PIANA	PLAIN WASHER	RONDELLE PLANE	ABSTANDSRING	ARANDELA LLANA			
8	638744	1	MOZZO	HUB	MOYEU	NABE	CUBO			
9	638748	1	GIUNTO ELASTICO	ELASTIC JOINT	JOINT ELASTIQUE	ELASTISCHE KUPPLUNG	JUNTA ELASTICA			
10	07.0713.0008	8	RONDELLA	WASHER	RONDELLE	SCHEIBE	ARANDELA			
11	07.0713.0024	20	VITE	SCREW	VIS	SCHRAUBE	TORNILLO			
12	07.0713.0009	12	RONDELLA ELASTICA	SPRING WASHER	RONDELLE ELASTIQUE	FEDERSCHEIBE	ARANDELA ELASTICA			
13	638747	1	CAMPANA	PROTECTION	CLOCHE	GLOCKE	CAMPANA			
14	09.0804.0000	1	PREDISPOSIZIONE VOLANO	HANDWHEEL ARRANGEMENT	PREDISPOSITION VOLANT	EINRICHTUNG SCHWUNGRAD	PREDISPOSICIÓN VOLANTE			
15	51.0901.5000	1	PROTEZIONE	GUARD	PROTECTION	SCHUTZ	PROTECCION			
16	53.3000.5800	1	COLLETTORE	MANIFOLD	COLLECTEUR	SAMMLER	COLECTOR			
17	09.0805.0030	1	TUBO GOMMA	RUBBER HOSE	TUYAU EN CAUTCHOUC	GUMMISCHLAUCH	TUBO DE GOMA			
18	09.0805.0005	1	MANICOTTO	SLEEVE	MANCHON	MUFFE	MANGA			
19	09.0805.0037	1	MANICOTTO	SLEEVE	MANCHON	MUFFE	MANGA			
20	04.0227.0067	2	FASCETTA	CLAMP	COLLIER	KLEMMSCHELLE	ABRAZADERA			
21	04.0227.0058	4	FASCETTA	CLAMP	COLLIER	KLEMMSCHELLE	ABRAZADERA			
22	09.4656.0000	1	PEDALE	PEDAL	PEDALE	PEDAL	PEDAL			
23	09.4656.0000	1	CAVO ACCELERATORE	GAS CABLE	CABLE ACCELERATEUR	GASKABEL	CABLE ACELERADOR			
24	09.0803.0007	2	MORSETTO	CLAMP	ETAU	KLEMME	BORNE			
25	09.0803.0008	1	SNODO	ARTICULATION	ARTICULATION	GELENK	ARTICULACION			
26	09.4655.0000	1	LEVA	LEVER	LEVIER	HEBEL	PALANCA			
27	51.0800.1800	1	STAFFA	BRACKET	ETRIER	BUEGEL	ESTRIBO			
28	01.4001.0012	4	VITE	SCREW	VIS	SCHRAUBE	TORNILLO			
29	01.0001.0357	16	VITE	SCREW	VIS	SCHRAUBE	TORNILLO			
30	01.0023.0055	16	DADO	NUT	ECROU	MUTTER	TUERCA			
31	01.0023.0057	4	DADO	NUT	ECROU	MUTTER	TUERCA			
32	09.0805.0036	1,6	TUBO GOMMA	RUBBER HOSE	TUYAU EN CAUTCHOUC	GUMMISCHLAUCH	TUBO DE GOMA			
33	09.4645.0003	1	CORDA LEVA ACCELERATORE	GAS LEVER CORD	CORDE LEVIER ACCELERATEUR	KABEL HANDGASHEBEL	CABLE PALANCA ACELERADOR			
34	09.0806.0029	1	RACCORDO	PIPE FITTING	RACCORD DE TUYAU	ROHRVERBINDUNG	CONEXIÓN			
36	638243	1	FILTRO OLIO	OIL FILTER	FILTRE A HUILE	ÖLFILTER	FILTRO ACEITE	◆		

POS.	CODICE	Q.tà	DENOMINAZIONE	DESCRIPTION	DESIGNATION	BENENNUNG	DENOMINACIONES	NOTE		
								A	B	C
36	07.0740.0056	1	TELAIO	FRAME	CHASSIS	RAHMEN	BASTIDOR			
37	07.0740.0057	1	VETRO	GLASS	VERRE	CLASSCHEIBE	VIDRIO			
38	07.0740.0058	1	GUARNIZIONE	SEAL	JOINT	DICHTUNG	GUARNICIÓN			
39	07.0740.0059	2	VITE	SCREW	VIS	SCHRAUBE	TORNILLO			
40	07.0740.0061	2	DADO	NUT	ECROU	MUTTER	TUERCA			
41	07.0740.0063	2	RONDELLA	WASHER	RONDELLE	SCHEIBE	ARANDELA			
42	07.0740.0064	2	VITE	SCREW	VIS	SCHRAUBE	TORNILLO			
43	07.0740.0065	1	CLIP	CLIP	CLIP	CLIP	CLIP			
44	07.0740.0060	1	VITE	SCREW	VIS	SCHRAUBE	TORNILLO			
45	07.0740.0016	1	RONDELLA	WASHER	RONDELLE	SCHEIBE	ARANDELA			
46	07.0740.0062	1	RONDELLA	WASHER	RONDELLE	SCHEIBE	ARANDELA			
47	07.0740.0027	4	TAPPO	PLUG	BOUCHON	STOPFEN	TAPÓN			
48	07.0740.0028	1	CAPPELLOTTO ESAGONALE	HEX CAP	COUVERCLE HEXAGONAL	SECHSECKIGE ABSCHLUSSKAPPE	CAPUCHÓN HEXAGONAL			
49	07.0740.0179	1	PORTIERA INFERIORE COMPLETA	LOWER DOOR	PORTE INFERIEURE	UNTERE TÜR	PUERTA INFERIOR			
50	07.0740.0180	1	PORTIERA SUPERIORE COMPLETA	UPPER DOOR	PORTE SUPERIEURE	OBERE TÜR	PUERTA SUPERIOR			
51	07.0740.0029	1	MANIGLIA	HANDLE	POIGNEE	HANDGRIFF	MANIJA			
52	07.0740.0030	1	PERNO	PIN	PIVOT	BOLZEN	PERNO			
53	07.0740.0031	2	CAPPELLOTTO ESAGONALE	HEX CAP	COUVERCLE HEXAGONAL	SECHSECKIGE ABSCHLUSSKAPPE	CAPUCHÓN HEXAGONAL			
54	07.0740.0014	5	CAPPELLOTTO ESAGONALE	HEX CAP	COUVERCLE HEXAGONAL	SECHSECKIGE ABSCHLUSSKAPPE	CAPUCHÓN HEXAGONAL			
55	07.0740.0047	1	ADESIVO	LABEL	ETIQUETTE	AUFKLEBER	ETIQUETA			
56	07.0740.0032	1	RONDELLA	WASHER	RONDELLE	SCHEIBE	ARANDELA			
57	07.0740.0034	1	GOMMINO	RUBBER	CAOUTCHOUC	GUMMI	GOMA			
58	07.0740.0035	2	BOCCOLA	BUSHING	DOUILLE	BÜCHSE	CASQUILLO			
59	07.0740.0036	2	RONDELLA	WASHER	RONDELLE	SCHEIBE	ARANDELA			
60	07.0740.0037	2	RONDELLA	WASHER	RONDELLE	SCHEIBE	ARANDELA			
61	07.0740.0038	4	RONDELLA	WASHER	RONDELLE	SCHEIBE	ARANDELA			
62	07.0740.0039	1	MANIGLIONE	HANDLE	POIGNEE	HANDGRIFF	MANIJA			
63	07.0740.0040	2	CERNIERA	HINGE	CHARNIERE	SCHARNIER	CHARNELA			
64	07.0740.0041	1	VETRO	GLASS	VERRE	CLASSCHEIBE	VIDRIO			
65	07.0740.0042	2	VITE	SCREW	VIS	SCHRAUBE	TORNILLO			
66	07.0740.0043	1	VITE	SCREW	VIS	SCHRAUBE	TORNILLO			
67	07.0740.0044	2	VITE	SCREW	VIS	SCHRAUBE	TORNILLO			
68	07.0740.0045	2	DADO AUTOBLOCCANTE	STOP NUT	ECROU DE SURETE	SPERRMUTTER	TUERCA AUTOTRABADORA			
69	07.0740.0046	3	DADO AUTOBLOCCANTE	STOP NUT	ECROU DE SURETE	SPERRMUTTER	TUERCA AUTOTRABADORA			
70	07.0740.0033	1	GOMMINO	RUBBER	CAOUTCHOUC	GUMMI	GOMA			

CLICK HERE TO **DOWNLOAD** THE COMPLETE MANUAL

- Thank you very much for reading the preview of the manual.
- You can download the complete manual from: www.heydownloads.com by clicking the link below



- Please note: If there is no response to CLICKING the link, please download this PDF first and then click on it.

CLICK HERE TO **DOWNLOAD** THE COMPLETE MANUAL