

# EP中力

EPT20-16EA

EPT20-18EA

D40

Electric Pallet Truck

## 电动搬运车

Parts Manual

零件目录

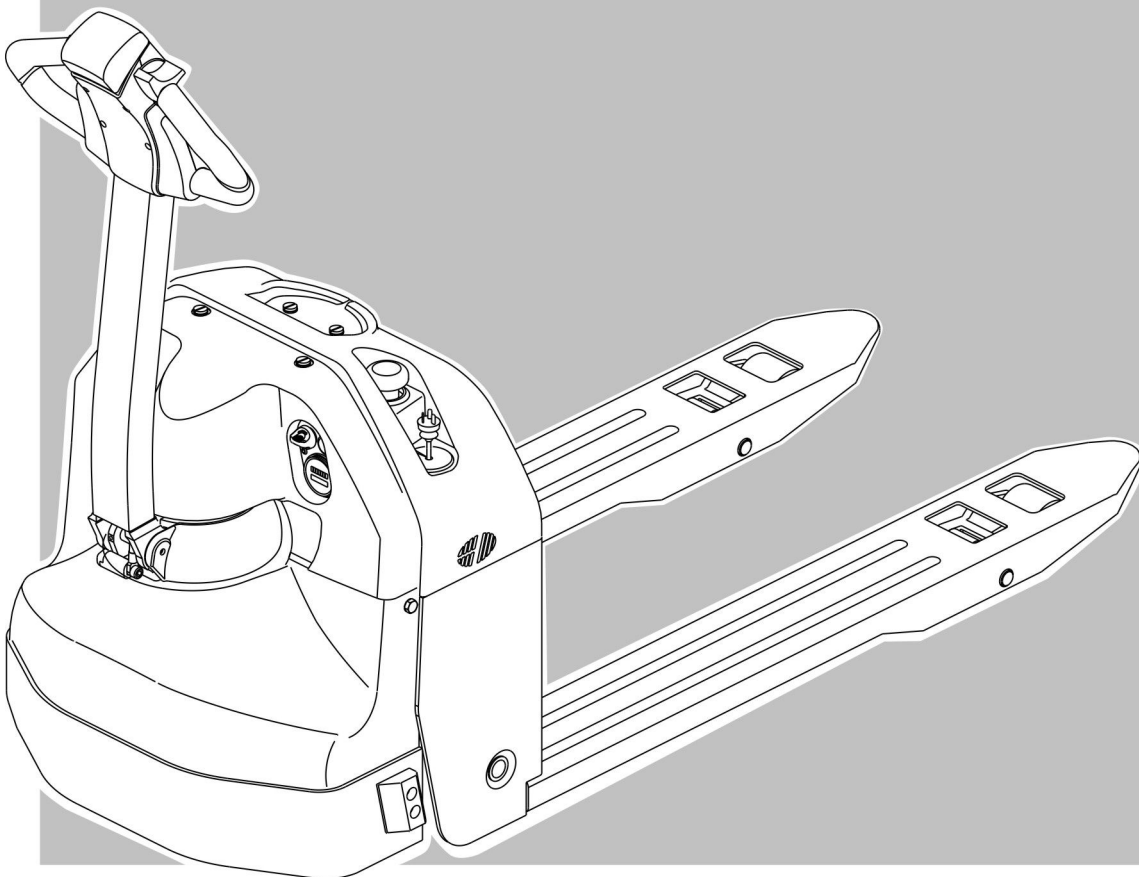

CE

CE CERTIFICATE

CLICK HERE TO **DOWNLOAD** THE COMPLETE MANUAL

- Thank you very much for reading the preview of the manual.
- You can download the complete manual from: [www.heydownloads.com](http://www.heydownloads.com) by clicking the link below



- Please note: If there is no response to CLICKING the link, please download this PDF first and then click on it.

CLICK HERE TO **DOWNLOAD** THE COMPLETE MANUAL

## Index 目录

<b>1000 Frame System 车身系统</b>	
0101 Frame System (Double Wheel) 车身系统 (双轮)	3
0102 Frame System (Single Wheel) 车身系统 (单轮)	6
0103 Connecting Link (Double Wheel) 连杆总成 (双轮)	8
0104 Connecting Link (Single Wheel) 连杆总成 (单轮)	10
0105 Load Wheel 承载轮	12
0106 Cover Assembly 外罩总成	14
0107 Caster Assembly 万向轮总成	16
<b>2000 Driving System 驱动系统</b>	
0201 Driving System 驱动系统	19
0202 Gear Case Assembly 减速箱总成	21
020201 Gear Case Assembly 减速箱总成	23
0203 Motor Assembly 电机总成	25
<b>3000 Operating Control System 操作系统</b>	
0301 Operating Control System 操作系统	28
0302 Control Pod Assembly 操作手柄头总成	30
0303 Upper Cover Assembly 上盖总成	32
0304 Button Reverser Assembly 紧急反向开关	34
<b>4000 Hydraulic System 液压系统</b>	
0401 Hydraulic System 液压系统	37
0402 Lifting Cylinder 起升油缸	39
0403 Pump & Motor Assembly 液压站总成	41
<b>5000 Electrical System 电气系统</b>	
0501 Electrical System 电气系统	44
0502 Electrical Component Assembly 电气元件总成	46
0503 Electrical Component Assembly 电器元件总成	48
0504 Wire Harness Assembly 线束总成	50
0505 Cable Assembly 电缆总成	52
<b>6000 Blocking Shelf Assembly 挡货架总成</b>	
0601 Blocking Shelf Assembly 挡货架总成	55
<b>8000 Cold Storage System 冷库系统</b>	
0801 Operating Control System 操作系统	58
0802 Control Pod Assembly 操作手柄头总成	60
0803 Cold Storage System 冷库系统	62
0804 Wire Harness Assembly 线束总成	64

### 0104 Connecting Link (Single Wheel)

#### 连杆总成 (单轮)

Index	Part No.	Part Name	No.	Applied Date	Remark
序号	零件编号	零件名称	数量	适用日期	备注
1	See Form 1.2	Down Link	1		
2	0000-001034-00	Bushing 2020F	2		
3	1219-140001-00	Shaft	2		
4	0000-000101-00	Nut M22×1.5	2		
5	1219-142200-00	Connector	2		
6	See Form 1.3	Long Link	2		Page 3
7	0000-000907-00	Bushing 2020	4		
8	01 1115-130005-0B	Wheel Bracket	2	-110713	
	02 1115-130005-4A	Wheel Bracket	2	110713-	
9	0000-000908-00	Bushing 2015 F	4		
10	1115-130003-00	Shaft	2		
11	0000-000708-00	Round Pin $\phi 5 \times 35$	8		
12	1115-130007-40	Shaft	2		
13	1115-133000-40	Load Wheel See 0105	2		单轮总成 见 0105
14	0000-000435-00	Flatwasher $\phi 20$	4		
15	See Form 1.3	Long rod	1		Page 3
16	1115-130008-00	Washer	4	110713-	

0202 Gear Case Assembly

减速箱总成

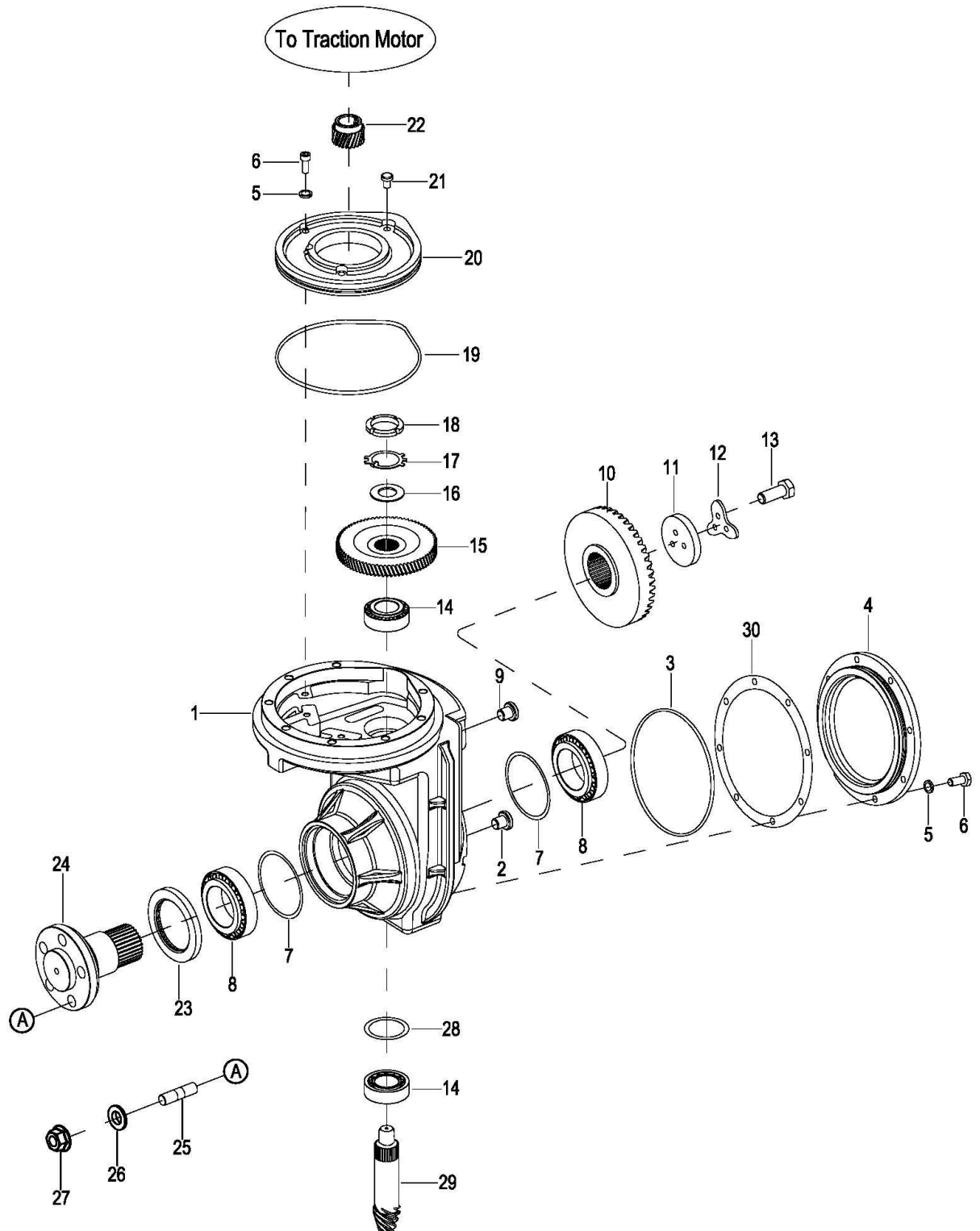

## 0302 Control Pod Assembly

## 操作手柄头总成

Index	Part No.	Part Name	No.	Applied Date	Remark
序号	零件编号	零件名称	数量	适用日期	备注
1	1120-342000-00	Cap Assembly	1		Without Wire
2	1120-340005-00	Travelling Knob R	1		
3	0000-000038-00	Lockwasher ø3	2		
4	0000-000037-00	Screw M3×12	2		
5	0000-000004-00	Screw M5×12	2		
6	0000-000206-00	Lockwasher ø5	4		
7	0000-000390-00	Flatwasher ø5	4		
8	0000-000088-00	Screw M4×8	2		
9	0000-000122-00	Lockwasher ø4	2		
10	0000-000702-00	Flatwasher ø4	2		
11	0000-000322-00	Screw M8×25	2		
12	0000-000159-00	Lockwasher ø8	2		
13	0000-000176-00	Flatwasher ø8	2		
14	1120-340003-00	Travelling Knob L	1		
15	1120-343000-00	Button Reverser Cover	1		Without Wire
16	0000-000004-00	Screw M5×12	2		
17	0000-000035-00	Screw M5×20	4		
18	1120-340002-00	Cover	1		
19	1120-341000-00	Gripe	1		
20	1120-340001-00	Pod	1		
21	1220-520008-0C	Accelerator Assembly	1		
22	0000-000010-00	Screw M5×6	1		
23	1120-343000-00-B	Reversing Switch Assembly See 0304	1		With wire
24	1120-342000-00-B	Cap Assembly See 0303	1		With wire



### 0504 Wire Harness Assembly

#### 线束总成

Index	Part No.	Part Name		No.	Applied Date	Remark
序号	零件编号	零件名称		数量	适用日期	备注
1	1118-520001-00	Master Wire Harness	主线束	1		
2	1120-500010-00	Fuse 10A	保险丝 10A	1		
3	1118-520002-00	Switching Wire Harness	转接线束	1		
4	1118-520004-00	Wire Harness Of Pump	液压站线束	1		

CLICK HERE TO **DOWNLOAD** THE COMPLETE MANUAL

- Thank you very much for reading the preview of the manual.
- You can download the complete manual from: [www.heydownloads.com](http://www.heydownloads.com) by clicking the link below



- Please note: If there is no response to CLICKING the link, please download this PDF first and then click on it.

CLICK HERE TO **DOWNLOAD** THE COMPLETE MANUAL