

Ditch Witch[®]

FX30

ISSUE NO. 42PL-04/19
For Replacement Copy Order **P/N 053-087**

This product and its use may be covered by one or more patents at
<http://patents.charlesmachine.works>.

This manual contains information concerning the following models:
FX30 T4i, FX30 500 gal, 800 gal & 1200 gal Fluid Excavator system

Copyright 2004, 2005, 2006, 2007, 2008, 2009, 2010, 2011, 2012, 2013, 2014, 2015, 2016, 2017,
2018, 2019 by The Charles Machine Works, Inc.

 **Ditch Witch**, Ditch Witch, and CMW are registered trademarks of The Charles Machine Works, Inc.

CLICK HERE TO **DOWNLOAD** THE COMPLETE MANUAL

- Thank you very much for reading the preview of the manual.
- You can download the complete manual from: www.heydownloads.com by clicking the link below



- Please note: If there is no response to CLICKING the link, please download this PDF first and then click on it.

CLICK HERE TO **DOWNLOAD** THE COMPLETE MANUAL

**DECAL LOCATION
FX30T4 500 GAL
BEGINS WITH S/N CMWFX30XC80000546**

REF NO.	PART NUMBER	QTY	DESCRIPTION	REMARKS
	275-884		DECAL KIT - FX30 - 500 GAL	
1	275-120	1	RESERVOIR (THF)	
2	274-352	AR	HI VIS STRIPE (2", SOLD PER 1')	104" TANK, 209" TRAILER
3	273-475	1	WARNING READ MANUAL	
4	270-5127	2	BATTERY	
5	270-5701	1	COOLANT DRAIN	
6	273-281	2	DITCH WITCH W/STRIPE	SEE FOOTNOTE 2
7	273-280	2	FX30 MODEL ID W/STRIPE	
8	275-184	3	WARNING MOVING PARTS	
9	273-314	1	FX30 OPERATOR INSTRUCTIONS	
10	270-5131	1	BATTERY DISCONNECT SWITCH	
11	274-724	1	ONE CALL NOTIFICATION	
12	275-497	1	OIL DRAIN	
13	275-400	1	NOTICE OIL LEVEL	
14	275-355	2	CAUTION HOT PARTS	
15	274-442	5	LIFT LOCATION	
16	700-009	1	CAUTION WEAR HEARING PROTECTION	
17	274-291	1	SOUND POWER	(102 dB SEE FOOTNOTE 1)
18	275-148	1	FUEL TANK (DIESEL)	
19	273-231	2	WARNING CYLINDER LOCK	
20	270-5647	1	WATER/RETURN/PRESSURE	
21	273-146	1	NOTICE ADD COOLANT	
22	270-2054	1	FX30 INSTRUMENT PANEL	NEW STYLE (BEGINS WITH S/N#CMWFX30XC80000546
	273-201	1	FX30 INSTRUMENT PANEL	OLD STYLE, NOT PART OF KIT (ENDS WITH S/N#CMWFX30XC80000545
23	273-208	1	NOTICE GREASE AND CHECK OIL	
24	273-193	1	FX30 STRIPE	
25	273-283	1	DITCH WITCH W/OUTLINE	
26	273-483	1	WARNING FIRE OR EXPLOSION	
27	273-206	2	BASE DRAIN PLUG	
28	270-5648	1	HYDRAULIC/PRESSURE/RETURN	
29	275-149	1	COOLANT	
30	270-6903	1	CAUTION FLYING OBJECTS	
31	273-212	1	NOTICE CLEAN FILTER DAILY	

FOOTNOTES

1. NOT PART OF KIT.
2. PLACE BOTTOM OF DECAL 32" FROM BASE MOUNT WELD.
3. LOCATE DECAL ON BATTERY SO THAT DECAL IS VISIBLE WHEN VIEWING BATTERY.
4. LOCATE DECAL WITHIN 3 INCHES OF TRAILER CERTIFICATION TAG.

DECAL LOCATION

FX30T4 800 GAL

BEGINS WITH S/N CMWFX30XV80000547

REF NO.	PART NUMBER	QTY	DESCRIPTION	REMARKS
34	273-209	2	OPEN/CLOSE	
35	273-483	1	WARNING FIRE OR EXPLOSION	
36	273-200	1	DANGER CONFINED SPACE	
37	273-282	1	DITCH WITCH W/LOGO	
38	273-291	4	WHITE HI VIS STRIPE	
39	273-203	1	TEST PORT	

FOOTNOTES

1. NOT PART OF KIT.
2. PLACE BOTTOM OF DECAL 32" FROM BOTTOM OF BASE MOUNT WELD.
3. LOCATE DECAL ON BATTERY SO THAT DECAL IS VISIBLE WHEN VIEWING BATTERY.

DECAL LOCATION T9S SERIES VAC TRAILERS

REF NO.	PART NUMBER	QTY	DESCRIPTION	REMARKS
	270-5548		T9S SERIES VAC TRAILER SERVICE DECAL KIT	INCLUDES REF NO:S 1 THRU 5
1	273-475	1	WARNING READ OPERATOR MANUAL	
2	270-5127	1	BATTERY	NOT USED ON HYDRAULIC BRAKE TRAILERS
3	274-352	AR	HI VIS STRIPE (2", SOLD PER 1')	VARIOUS LENGTHS AND QUANTITIES, 141" TOTAL
4	270-2043	1	T9S TIRE PRESSURE LABEL	SEE FOOTNOTE 1
5	270-7584	1	NATM DECAL	LOCATE NEAR TRAILER CERTIFICATION TAG

FOOTNOTES:

1. LOCATE DECAL WITHIN 3 INCHES OF TRAILER CERTIFICATION TAG.

OIL FILTER ENGINE COMPONENTS (TIER 4i)
BEGINS W/ S/N CMWFX30XV80000547, 800 GAL & CMWFX30XC80000546, 500 GAL
ENDS WITH S/N CMWFX30XPC0001571

REF NO.	PART NUMBER	QTY	DESCRIPTION	REMARKS
1	195-1169	1	"OBS" ENGINE-T4i KUBOTA D1105-T-E3B	INCLUDES REF NO:S 5-12 AND 16-28
2	154-420	2	CONNECTOR (08N-06090)	
3	150-1936	1	CONNECTOR (M16-1.50-060)	
4	150-1935	1	ELBOW (M16-1.50-060)	
5	195-1265	1	ALTERNATOR, KUBOTA 40A REAR POST	
6	195-1822	1	FAN BELT	
7	194-873	1	STARTER, 1.4KW	
8	194-881	1	OIL FILTER	
9	502-161	1	REMOTE HEAD	
10	105-894	1	LOCKNUT(M10-1.50,PRV TRQ,10.9)	
11	106-617	1	SCREW (M10-1.50 X 80MM)	
12	105-226	1	WASHER (5/16")	
13	300-5775	1	REMOTE OIL FILTER BRACKET	
14	515-265	1	HOSE (060FX-14"-3000)	
15	154-737	1	HOSE (060FX90-17"-3000)	
16	217-952	1	OIL PRESSURE SWITCH	
17	500-1255	1	CONNECTOR 2	
18	502-163	1	O-RING	
19	502-162	1	BASE (OIL FILTER)	
20	502-166	1	O-RING	
21	500-1254	1	CONNECTOR 1	
22	502-165	1	COLLAR	
23	149-326	1	GASKET, MUFFLER	
24	194-218	1	WATER PUMP	USED ON T2 ENGINES
25	194-380	1	FAN PULLEY	
26	194-379	1	FUEL PUMP, MECHANICAL	
27	194-386	1	FUEL FILTER ELEMENT	
28	194-378	1	FLYWHEEL & RING GEAR	
29	213-338	1	TEMPERATURE SWITCH	
30	106-162	2	FLG SCREW (M8-1.25 X 20MM, GD8)	

NOT SHOWN:

194-383	1	GLOW PLUG
213-306	1	STOP SOLENOID
194-210	1	THERMOSTAT
153-352	1	THERMOSTAT GASKET
153-353	1	WATER PUMP GASKET
194-381	1	INJECTION PUMP
149-536	1	FUEL FILTER
500-2144	1	WATER PUMP, KUBOTA

INCLUDES FUEL FILTER AND MOUNT BRACKET
 USED ON 194-1169 ENGINE T4i

FOOTNOTES:

EXHAUST & THROTTLE

ENDS WITH S/N CMWFX30XC80000532, 800 GALLON UNITS

ENDS WITH S/N CMWFX30XL80000535, 500 GALLON UNITS

REF NO.	PART NUMBER	QTY	DESCRIPTION	REMARKS
1.	194-365	1	EXHAUST MUFFLER	
2.	149-326	1	GASKET, MUFFLER	
3.	105-806	4	SCREW (M8-1.25 X 25MM)	
4.	105-091	4	LOCK WASHER (5/16")	
5.	106-389	4	WASHER (M8)	
6.	106-103	3	BOLT (1/4-NC X 1/2", BUT SOC)	
7.	106-386	2	FLG LOCKNUT (M8-1.25)	
8.	194-219	1	THROTTLE CABLE	
9.	309-610	1	MUFFLER BRACKET	
10.	105-796	1	FLG LK SCREW (M8-1.25 X 20MM)	
11.	309-611	1	THROTTLE BRACKET	
12.	117-886	1	E-RING (.25")	
13.	105-826	3	FL LK BOLT (3/8-NC X 1")	
14.	105-834	3	FLG LOCKNUT (3/8-NC)	
15.	106-048	3	LOCKNUT (#10-24)	
16.	106-049	3	BOLT (#10-24 X 3/4", PLPS)	
17.	110-333	1	BOLT-ON CLAMP (1")	
18.	106-958	1	SCREW (M10-1.25 X 20MM)	
19.	106-381	1	FLG LK SCREW (M8-1.25 X 25MM)	
20.	106-561	1	LOCKNUT (M8-1.25, PRV TRQ,10.9)	
21.	106-396	3	WASHER (M10-HARDENED)	

NOT SHOWN:

FOOTNOTES:

NOTE:

ENGINE BASE

FX30/500 BEGINS WITH S/N CMWFX30SH70000183

FX30/800 BEGINS WITH S/N CMWFX30XA70000189

ENDS WITH S/N CMWFX30XC80000532, 800 GALLON UNITS

ENDS WITH S/N CMWFX30XL80000535, 500 GALLON UNITS

REF PART

NO. NUMBER QTY DESCRIPTION

REMARKS

REF NO.	PART NUMBER	QTY	DESCRIPTION	REMARKS
1	310-820	1	BASE	
2	310-824	2	BLOWER LEG	
3	310-835	2	BRACE	
4	300-3261	1	TOP PLATE ASSEMBLY	
5	300-3258	1	ADJUSTABLE SIDE PLATE	
6	318-830	1	COUPLING SHIELD	
7	310-822	1	ENGINE LEG	
8	310-823	1	ENGINE LEG	
9	310-827	2	RADIATOR MOUNT	
10	314-478	1	CROSS MEMBER	SEE FOOTNOTE 1
11	318-859	1	FUEL FILTER BRACKET	
12	105-071	2	WASHER (1/2")	
13	105-295	1	BOLT (1/2-NC X 5-1/2")	SEE FOOTNOTE 2
14	105-826	15	FLG LK BOLT (3/8-NC X 1")	
15	105-834	21	FLG LOCKNUT (3/8-NC)	
16	105-830	2	FLG LK BOLT (1/2-NC X 1-1/4")	
17	106-198	1	FLG LOCKNUT (1/2-NC, GD8)	
18	107-013	1	BOLT (1/2-NC X 7")	
19	105-827	6	FLG LK BOLT (3/8-NC X 1-1/4")	
20	106-090	2	LOCK WASHER (M10)	
21	107-357	2	SCREW (M10-1.25 X 35MM, 10.9)	TORQUE TO 37 FT LBS
22	105-873	1	FLG LK BOLT (5/16-NC X 1")	
23	105-003	1	FLG LOCKNUT (5/16-NC)	
24	106-381	4	FLG LK SCREW (M8-1.25 X 25MM)	
25	314-477	2	LOWER RADIATOR MOUNT	SEE FOOTNOTE 1

NOT SHOWN:

115-686 AR BULK EDGE USE 4 @ 2"

FOOTNOTES:

1. THESE PARTS ARE INCLUDED WITH RADIATOR P/N 194-264 AND ARE NOT SERVICE PARTS.
2. THE TENSIONING BOLT WILL REQUIRE NUT 106-198 AND WASHER 105-071 IF THE TOP PLATE ASSEMBLY, 300-3261, DOES NOT HAVE A WELDNUT.

NOTE:

BLOWER & PUMP (TIER 4i) (TIER 3)

BEGINS W/ S/N CMWFX30XV80000547, 800 GAL & CMWFX30XC80000546, 500 GAL
ENDS WITH S/N CMWFX30XPC0001571

REF NO.	PART NUMBER	QTY	DESCRIPTION	REMARKS
1	170-1035	1	STRAIGHT ARM TENSIONER	
2	170-1036	1	SHEAVE QD2/3V4.50	
3	170-1037	1	SHEAVE TL2/3V6.00	
4	170-1039	1	SHEAVE TL2/3V5.00	
5	170-291	1	BELT (2/3V-38.5")	
6	170-1042	1	SHEAVE TL2A3.8/B4.2	
7	157-350	1	PRESSURE PUMP W/CLUTCH	SEE NOT SHOWN FOR SERVICE PARTS
8	120-183	1	FX30 BLOWER	SEE FOOTNOTE 1
9	165-923	1	KEY (1/4 X 2.00)	
10	160-1103	1	ENGINE SHAFT	
11	160-1117	1	KEY (3/8" X 3.24")	
12	170-1033	1	DUAL BEARING IDLER HUB	
13	170-1043	2	BELT (A41)	
14	106-380	4	FLG LK SCREW (M8-1.25 X 16MM)	USE LOCTITE 242
15	106-004	6	BOLT (3/8-NC X 1-3/8", GD8)	TORQUE TO 31 FT-LBS.
16	125-030	2	BALL BEARING (669)	USE LOCTITE 648 ON INNER AND OUTER RACES
17	106-575	1	BOLT (1/2-NC X 2-1/4", GD8)	TORQUE TO 80 FT-LBS.
18	500-192	3	BOLT (1/4-NC X 7/8", SOC, GD8)	TORQUE TO 15 FT-LBS.
19	105-549	1	BOLT (1/2-NC X 3-3/4", GD8)	
20	170-1038	2	TAPER-LOCK BUSHING 1610 1-1/2	SCREWS INCLUDED WITH BUSHING; ADD LOCTITE 242, TORQUE=15 FT-LBS
21	300-5222	1	BEARING SHOULDER BUSHING	
22	106-397	1	WASHER (M12, HARDENED)	
23	105-1272	12	CAM WASHER (M10, 21.0MM O.D.)	
24	300-6745	1	IDLER BUSHING SPACER	
25	170-1040	1	TAPER-LOCK BUSHING 1610 1-1/8	SCREWS INCLUDED WITH BUSHING; ADD LOCTITE 242, TORQUE=15 FT-LBS
26	105-1265	6	SCREW (M10-1.25 X 30MM, 10.9)	
27	106-198	2	FLG LOCKNUT (1/2-NC, GD8)	

NOT SHOWN:

153-099	1	SPRAY PUMP (3000 PSII)
166-390	1	CLUTCH (12V)
153-099	1	EXTRACTOR PACKING KIT
100-089	1	UNLOADER KIT
100-090	1	PACKING KIT
100-091	1	VALVE KIT
100-092	3	PISTON KIT
165-915	AR	KEY (5/16"-1")
500-2394	1	WASHER, BRASS -21.5MM
500-2395	1	WASHER, BRASS -17.5MM
500-2493	1	DIPSTICK

FOOTNOTES:

1. BLOWER SERVICE PARTS: 500-1932 SHAFT SEAL (1 REQ'D) AND 500-1933 MAIN SEAL (4 REQ'D)

NOTE:

LOWER DECK**FX30**

ENDS WITH S/N CMWFX30XC80000532, 800 GALLON UNITS

ENDS WITH S/N CMWFX30XL80000535, 500 GALLON UNITS

REF PART

NO.	NUMBER	QTY	DESCRIPTION	REMARKS
1.	309-566	1	ENGINE / PUMP MOUNT	
2.	105-137	16	CLIP NUT (5/16-NC)	
3.	117-531	4	ISOLATOR	
4.	105-117	8	WASHER (5/16")	
5.	105-873	16	FLG LK BOLT (5/16-NC X 1")	
6.	501-153	10	FLG LK BOLT (3/8-NC X 5/8 ")	
7.	107-754	4	CLIP NUT (1/4", CVR .125" THK)	
8.	105-820	4	FLG LK BOLT (1/4-NC X 3/4 ")	
9.	309-567	1	BATTERY TRAY	
10.	115-686	AR	BULK EDGING	USE 1 @ 24" CENTERED
11.	115-686	AR	BULK EDGING	USE 2 @ 34"
12.	115-686	AR	BULK EDGING	USE 1 @ 6"

NOT SHOWN:

FOOTNOTES:

NOTE:

FUEL SYSTEM**BEGINS WITH S/N CMWFX30XPC0001572****INCLUDES UNITS W/ S/N'S BEFORE THESE THAT HAVE FRAME KIT 190-2000 INSTALLED**

REF NO.	PART NUMBER	QTY	DESCRIPTION	REMARKS
1	364-546	1	FUEL TANK	
2	117-582	1	FUEL TANK ISOLATOR	
3	165-704	1	GASKET	
4	214-844	1	FUEL SENDER	
5	153-717	1	FUEL CAP	
6	110-560	5	POP RIVET (3/16" X 1/2", ALUM)	
7	364-666	1	FILLER NECK STANDOFF	
8	155-708	1	O-RING (218-D70)	
9	364-663	1	FILLER NECK SCREEN	
10	110-249	10	WORM CLAMP (1/4" TO 5/8")	
11	116-108	111	BULK HOSE (5/16", SOLD PER 1")	A=18"; B=18"; C=5"; D=70"
12	153-872	1	S/O COUPLER (06N-04H90, BRS)	
13	114-002	1	PLUG (06N, SOC)	
14	194-386	1	FUEL FILTER ELEMENT	
15	115-381	82	BULK HOSE (1/4", SOLD PER 1")	
16	153-636	1	INLINE FUEL FILTER (3/8")	

NOT SHOWN:

FOOTNOTES:

1. S/O COUPLER (06N-05H90) IS SUPPLIED WITH TANK.

NOTE:

BATTERY

**FOR UNITS THAT HAVE FRAME KIT 190-2000 INSTALLED; CAN INCL. UNITS BEFORE S/N:
BEGINS WITH S/N CMWFX30XPC0001572**

REF NO.	PART NUMBER	QTY	DESCRIPTION	REMARKS
1	215-244	1	BATTERY	
2	300-5211	1	BATTERY TRAY	
3	107-754	2	CLIP NUT (1/4", CVR .125" THK)	
4	213-054	1	BAT CABLE (4 GA X 25", BLK)	
5	213-055	1	BAT CABLE (4 GA X 80", BLK)	
6	217-819	1	BATTERY DISCONNECT SWITCH	
7	270-5131	1	BATTERY DISCONNECT	
8	107-554	2	BATTERY HOLD DOWN	TORQUE TO 60 FT-LB
9	105-117	2	WASHER (5/16")	
10	105-821	2	FLG LK BLT (1/4-NC X 1-3/4")	
11	213-057	1	BAT CABLE (4 GA X 55", RED)	
12	213-056	1	BAT CABLE (4 GA X 80", RED)	
13	116-389	53	BULK TUBING (3/4".SOLD PER FT)	
14	215-305	1	BAT CABLE (4 GA X 30", BLK)	
15	106-162	1	FLG SCREW (M8-1.25 X 20MM, GD8)	
16	106-561	1	LOCKNUT (M8-1.25,PRV TRQ,10.9)	
18	116-389	75	BULK TUBING (3/4".SOLD PER FT)	SEE FOOTNOTE I
19	301-2151	1	FUSE MOUNT BRACKET	
20	363-714	1	MODIFIED FUSE PANNEL ASSEMBLY	
21	106-058	2	BOLT (#6-32 X 1-1/8", RD SLT)	
22	211-1000	1	BK/AMI 80 AMP FUSE	
23	105-1272	2	CAM WASHER (M10, 21.0MM O.D.)	
24	105-1265	2	SCREW (M10-1.25 X 30MM, 10.9)	
25	105-215	2	NUT (#6-32)	
26	195-418	2	LOCK WASHER (#10)	
27	106-013	2	WASHER (3/16")	

NOT SHOWN:

FOOTNOTES:

I. SEE PARTS PAGE IID0365602 (12 VDC POWER UNIT W/ THERMAL SW) FOR SERVICE PARTS.
BEGINS WITH S/N-----

NOTE:

**NO REVERSE FLOW BLOWER PLUMBING (TIER 4i)
 BEGINS WITH S/N CMWFX30XPC0001572**

REF NO.	PART NUMBER	QTY	DESCRIPTION	REMARKS
1	319-988	1	CAP MOUNT	
2	106-162	1	FLG SCREW (M8-1.25 X 20MM, GD8)	
3	106-386	1	FLG LOCKNUT (M8-1.25)	
4	362-1552	1	INSULATION	
5	105-820	8	FLG LK BOLT (1/4-NC X 3/4")	
6	107-754	7	CLIP NUT (1/4", CVR .125" THK)	
7	301-2482	1	COVER	
8	156-939	1	PLUG (48N)	
9	116-0005	1	SILENCER EXHAUST HOSE	
10	105-1308	1	T-BOLT CLAMP (4.00-4.31)	
11	106-048	1	LOCKNUT (#10-24)	
12	105-815	1	BOLT (#10-24 UNC X 1" PAN SLT)	
13	111-123	1	RAIN CAP (6")	
14	318-846	2	RAIN CAP COUNTERWEIGHT	

NOT SHOWN:

FOOTNOTES:

NOTE:

GAUGES

BEGINS WITH S/N _____; ENDS WITH S/N CMWFX30XC80000532, 800 GALLON UNITS
 BEGINS WITH S/N _____; ENDS WITH S/N CMWFX30XL80000535, 500 GALLON UNITS

REF NO.	PART NUMBER	QTY	DESCRIPTION	REMARKS
1	215-133	1	FUEL GAUGE	SEE FOOTNOTE 1
2	215-2594	1	HOUR METER	SEE FOOTNOTE 2
3	314-479	1	CONTROL PANEL	
4	213-419	1	5,000 PSI GAUGE	
5	217-907	2	ROCKER SWITCH (DPDT) ON-ON	
6	217-020	1	PILOT LIGHT	SEE FOOTNOTE 3
7	214-823	1	SHUT DOWN RELAY	SEE FOOTNOTE 6
8	214-563	1	RED LED (12V DC)	
9	214-852	1	IGNITION SWITCH	SEE FOOTNOTE 4
10	214-822	2	15 AMP BREAKER	
11	214-821	1	30 AMP BREAKER	
13	217-856	1	LAMPTIMER 12V	SEE FOOTNOTE 7. SEE FOOTNOTE 8.
14	217-710	3	MICRO RELAY (SPDT)	SEE NOTE 1
15	217-826	2	MINI RELAY (SPDT)	SEE NOTE 1
16	217-051	1	INSERT (RED) ENG TEMP	
17	217-021	1	INSERT (RED) ENG OIL PSI	
19	106-350	3	NUT, HEX, #8-32	
20	217-912	1	ROCKER SWITCH (DPDT) ON-ON-ON	
21	106-349	3	SCREW (#8-32 X 3/4" PAN)	
22	153-826	5	6 MM SNAP CAP	
23	106-056	3	EXT STAR WASHER (#10)	
24	106-040	2	EXT STAR WASHER (#6)	
25	105-189	2	SCREW (#6-32 X 1/2")	
27	105-215	2	NUT (#6-32)	
28	215-1877	1	HAND HELD REMOTE (2 BUTTON)	SEE FOOTNOTE 5

NOT SHOWN:

213-019 1 ENGINE HARNESS
 214-837 1 CONTROL PANEL HARNESS

FOOTNOTES:

- USE (1) 215-415, NIGHT LIGHT KIT (12V)
- HOUR METER INCLUDES : (2) 105-186, NUT (#10-24), & (2) 106-056, STAR WASHER (#10)
- USE (1) 217-020, BULB (12V DC) FOR SERVICE PART
- IGNITION SWITCH INCLUDES: 214-691 KEY, PAIR (BASE CODE); 214-962, SWITCH MOUNTING NUT; 214-963, LOCK PLUG W/ KEY (BASE CODE);
- 215-1877 HAND HELD REMOTE IS SUPPLIED WITH THE 215-2295 12V DC POWER UNIT, W/THERMAL SW
- INCLUDES TWO EACH OF REF 19, 21, 22, AND 23
- INCLUDES ONE EACH OF REF 19, 21, 22, AND 23
- LAMPTIMER, 217-826, IS SUPPLIED WITH ENGINE, 194-541.

NOTE:

- RELAY BASE SUPPLIED, WITH WIRING HARNESS BOLTS ON USING REF #22, 24, 25, AND 27

POWER PAC ENCLOSURE
ENDS WITH S/N: CMWFX30XC80000532, 800 GALLON UNITS
ENDS WITH S/N: CMWFX30XL80000535, 500 GALLON UNITS

REF NO.	PART NUMBER	QTY	DESCRIPTION	REMARKS
1	309-362	1	FRONT PANEL	
2	309-367	1	TOP ACCESS DOOR	
3	320-364	2	ACCESS DOOR	USED AFTER S/N
	309-364	1	SIDE PANEL	USED PRIOR TO S/N
4	309-363	1	REAR PANEL	
5	309-359	1	RIGHT ACCESS DOOR	
6	309-361	2	DOOR STOP	
7	309-360	1	LEFT ACCESS DOOR	
8	309-369	1	BASE	
9	117-558	7	ADJUST LEVER LATCH (LOCKING)	
	214-961		KEY, PAIR (BASE CODE)	
	217-309		LOCK PLUG 4/LATCH (BASE CODE)	
	110-757	7	LEVER LATCH (ADJUST, LOCKING)	OBSOLETE
	117-558	7	ADJUST LEVER LATCH (LOCKING)	
	110-596	-	KEYS (PAIR)	
10	105-617	2	LIFT OFF HINGE (OFFSET)	
11	111-002	2	LIFT OFF HINGE (OFFSET)	
12	110-699	4	PULL (1.210" X 5.190", BLACK)	
13	117-533	6	RUBBER BUMPER	
14	105-832	10	FLG LOCKNUT (1/4-NC)	
15	106-428	16	SCREW (M5-0.80 X 14MM, SOC)	USE LOCTITE 242 OR EQUIVALENT
16	106-056	24	EXT STAR WASHER (#10)	
17	105-820	28	FLG LK BOLT (1/4-NC, 3/4")	
18	107-754	28	CLIP NUT (1/4", CVR .125" THK)	
19	318-588	1	MANUAL COMPARTMENT	
20	105-836	4	FLG LOCK BOLT (1/4-NC X 1/2")	

NOT SHOWN:

FOOTNOTES:

NOTE:

INSULATION (TIER 4i)
BEGINS WITH S/N CMWFX30XPC0001572

REF NO.	PART NUMBER	QTY	DESCRIPTION	REMARKS
1	301-2471	1	FRONT PANEL	
2	301-2475	1	TOP ACCESS DOOR	
3	320-364	2	ACCESS DOOR	
4	301-2470	1	REAR PANEL	
5	309-360	1	LEFT ACCESS DOOR	
6	309-359	1	RIGHT ACCESS DOOR	
7	117-985	2	INSULATION	
8	309-361	2	DOOR STOP	
9	301-2478	1	BASE	
10	362-1647	1	HOOD INSULATION	
11	362-1266	1	HOOD INSULATION	
12	362-1545	1	INSULATION	
13	362-1253	1	THERMAL INSULATION	
14	362-1547	1	INSULATION	
15	117-888	26	BULK STRIP (1/2", SOLD PER 1")	USE 2 @ 13"
16	117-888	36	BULK STRIP (1/2", SOLD PER 1")	USE 2 @ 18"
17	362-1546	2	INSULATION	
18	362-1553	1	INSULATION	
19	362-1550	1	INSULATION	
20	117-486	2	INSULATION	
21	117-488	1	INSULATION	
22	117-487	1	INSULATION	
23	117-491	1	INSULATION	
24	362-1551	3	INSULATION	
25	362-1554	1	INSULATION	
26	117-499	2	INSULATION	
27	362-1549	1	INSULATION	

NOT SHOWN:

FOOTNOTES:

NOTE:

DOOR

**BEGINS WITH S/N FX25XLE0000176, FX30XCE0002017, FX50XVE0000183
FX60XVE000836**

REF NO.	PART NUMBER	QTY	DESCRIPTION	REMARKS
1	301-4505	1	DOOR	
2	153-451	1	RUBBER SEAL	
3	214-516	1	3-LIGHT BAR (MI5)	
4	105-095	2	WASHER (1/4")	
5	105-856	2	BOLT (1/4-NC X 1 1/4")	
6	214-524	3	RED LAMP (MI5)	
7	105-085	2	LOCKNUT (1/4"-NC)	
8	107-740	1	PIN	
9	105-439	2	WASHER (7/8")	
10	105-511	2	COTTER PIN (1/8" X 1-1/4")	
11	301-5318	1	DEFLECTOR	
12	106-194	6	FLANGE LOCKNUT (3/8-NC)	
13	107-898	1	U-BOLT (3/8-NC X 4.5")	
14	116-918	1	GROMMET (3/4", RUBBER)	
15	499-542	2	GLASS BOWL	
16	153-696	2	4" GASKET	
17	301-2647	2	SIGHTGLASS RETAINING RING	
18	105-834	2	FLG LOCKNUT (3/8-NC)	
19	499-543	2	HAND WHEEL	
20	150-3847	1	LEVER VALVE - BOLT ON (4")	SEE FOOTNOTE 1 & FOOTNOTE 2
21	105-874	4	FLG LK BOLT (3/8-NC X 1-1/2")	
22	157-387	1	FHC BODY (64-64N)	
23	153-915	1	FHC PLUG (1-64)	
24	117-476	2	CHAIN	
25	105-066	8	BOLT (1/2-NC X 1-3/4")	
26	105-065	8	LOCKNUT (1/2-NC)	
27	157-818	1	GASKET	
28	301-5772	1	VALVE ADAPTER	
29	153-1005	1	LEVER VALVE (6")	SEE FOOTNOTES 1 & 3
30	153-479	1	FHC ADAPTER (96-96N)	
31	111-096	1	FHC DUST CAP (96)	
32	117-480	2	SPLIT RING	

NOT SHOWN:

FOOTNOTES:

1. LOCTITE 277 BOLT 106-380 TO VALVE HANDLE 105-1213.
2. COMES WITH O-RING 157-013.
3. SERVICE PARTS: 105-1213 BRASS VALVE HANDLE, 106-380 FLG. LK. SCREW, 500-2503 GATE VALVE SHAFT & 500-2278 SHAFT SEAL.

NOTE:

REFER TO O-RING CHART (800-301) IN BACK OF BOOK FOR REPLACEMENT OF O-RINGS

500 & 800 HYD. DOOR LIFT

ENDS W/CMWFX25 _____, CMWFX30 _____, CMWFX60 _____, 500G;
 CMWFX30 _____, CMWFX60 _____, 800G; CMWFX60 _____, 300G

REF PART

NO.	NUMBER	QTY	DESCRIPTION	REMARKS
1	105-916	2	WASHER (1.031")	
2	318-932	2	FINAL LINK	
3	318-931	2	PIN	
4	115-499	8	KLIP RING (1.000")	
5	318-933	2	INTERMEDIATE LINK	
6	179-409	1	PIN	
7	318-930	1	SPACER	
8	179-624	1	LOCKOUT PIVOT PIN	
9	179-421	1	PIN	
10	125-800	1	COMPOSITION BUSHING (1")	
11	125-772	1	COMPOSITION BUSHING (1.5")	
12	320-164	1	CYLINDER LATCH BRACKET	
13	117-035	1	TORSION SPRING	
14	115-503	1	KLIP RING (.750")	
15	115-584	1	TORSION SPRING	
16	320-163	1	CYLINDER LOCK	
17	149-797	1	CYL (2.5 X 1.25 X 5.0)	
18	105-1279	1	WASHER	
19	105-329	2	WASHER (1")	

NOT SHOWN:

FOOTNOTES:

NOTE:

TANK AND SKID, 500 GAL.

BEGINS WITH S/N: FX25-CMWF25XAF0000243, FX30-CMWF30XCF0002469, FX50-CMWF50XPF0000289, FX60-CMWF60XJF0000902

END WITH S/N: FX25-CMWF25XHG0000327, FX30-CMWF30XCG0002795, FX50-CMWF50XCG0000422

REF NO.	PART NUMBER	QTY	DESCRIPTION	REMARKS
1	301-4175	1	500 GAL TANK W/ BOOM	SEE FOOTNOTE 1
2	107-714	3	WING NUT (5/8-NC)	
3	107-713	3	WASHER	
4	107-712	3	EYE BOLT	
5	107-711	3	CLEVIS PIN	
6	105-511	3	COTTER PIN (1/8" X 1-1/4")	
7	300-4155	1	FLANGE CAP PLATE	
8	105-874	3	FLG LK BOLT (3/8-NC X 1-1/2")	
9	322-390	3	SLEEVE	
10	157-818	1	GASKET	
11	300-4188	3	MOUNT PLATE	
12	106-194	3	FLANGE LOCKNUT (3/8-NC)	
13	217-108	1	STROBE LIGHT W/AMBER LENS	SEE FOOTNOTE 4
14	106-049	2	BOLT (#10-24 X 3/4", PLPS)	
15	106-048	2	LOCKNUT (#10-24)	
16	107-478	4	WING NUT (1/2-NC)	
17	110-833	2	SNAPPER PIN (3/8" X 2-3/4")	
18	310-697	2	CYLINDER LOCK	
19	309-835	2	PIN	
20	105-1200	12	BOLT (1/2-NC X 1-1/2", GD 8)	TORQUE TO 80 FT. LBS.
21	106-743	24	WASHER (5/31", HARDENED)	
22	105-065	12	LOCKNUT (1/2-NC)	
23	151-035	2	CYL (2.5 X 1.50 X 16.0)	SEE FOOTNOTE 3
24	125-772	4	COMPOSITION BUSHING (1.5")	
25	154-226	2	CONNECTOR (040-06S90)	
26	115-001	5	ZERK (02N)	
27	177-1062	2	PIN	
28	105-502	2	COTTER PIN (3/16" X 2")	
29	301-2220	1	500 GALLON SKID	SEE FOOTNOTE 2
30	116-259	16	BULK EDGE (1/2", SOLD PER INCH)	USE 2 @ 8 INCHES
31	106-210	4	BOLT (1/2-NC X 3")	
32	106-397	4	WASHER (M12, HARDENED)	
33	106-198	4	FLG LOCKNUT (1/2-NC, GD8)	
34	258-047	1	VACUUM PRESSURE GAUGE	
35	514-427	1	S/O COUPLER (040F-04H)	
36	110-249	2	WORM CLAMP (1/4" TO 5/8")	
37	309-836	2	PIN	

NOT SHOWN:

FOOTNOTES:

1. TANK 301-4175 IS OBSOLETE. IF REPLACING USE 302-1900.
2. SKID 301-2220 IS OBSOLETE. IF REPLACING USE 302-1880.
3. IF REPLACING CYLINDERS 151-035 WITH LARGER 3" DIAMETER CYLINDERS, USE KIT 190-2622.
4. STROBE LIGHT 217-108 IS OBSOLETE. IF REPLACING, USE KIT 190-2630.

NOTE:

REFER TO O-RING CHART (800-301) IN BACK OF BOOK FOR REPLACEMENT OF O-RINGS.

TANK

1200 GALLON VAC TANK

REF NO.	PART NUMBER	QTY	DESCRIPTION	REMARKS
1.	107-714	3	WING NUT (5/8-NC)	
2.	107-713	3	WASHER	
3.	300-5622	1	PRIMARY SHUT OFF	
4.	153-621	1	GASKET (12")	
5.	153-620	1	RUBBER SEAT (3")	
6.	258-054	1	FLOAT BALL (6")	
7.	107-712	3	EYE BOLT	
8.	105-511	3	COTTER PIN (1/8" X 1-1/4")	
9.	107-711	3	CLEVIS PIN	
10.	499-609	1	8" OPEN CAGE	
11.	214-103	1	PC 2 PIN 12010973 WPAK	
12.	215-2726	1	STROBE LIGHT (AMBER)	SEE FOOTNOTE I
13.	214-104	2	PACKARD MALE TERMINAL	
14.	320-179	-	SKID	
15.	125-781	2	COMPOSITION BUSHING (2.259")	
16.	318-485	1	MUFFLER CLAMP	
17.	300-4302	1	1200 GA. TANK	
18.	213-071	1	FX60 1200 STROBE HARNESS	
19.	106-709	16	FLG LK NUT (M12-1.75)	
20.	107-565	16	FLG LK SCREW (M12-1.75 X 40MM)	
21.	315-178	1	SCISSOR LIFT	
22.	183-837	2	TAPERED PIN (57.15MM X 180MM)	
23.	184-031	2	TAPERED INSERT (2.25")	
24.	106-798	2	SCREW (M20-2.50 X 55MM, 10.9)	
25.	315-341	-	TRAILER, 1200 GAL TANK	
26.	320-146	1	PROP ROD	
27.	347-888	1	SPRING LOADED PIN	
28.	106-796	2	SCREW (M4-.70 X 30MM)	
29.	320-466	1	PIN	
30.	110-228	1	LYNCH PIN (7/16" X 2")	
31.	157-645	2	WEATHER-PAC SEAL (2.80MM)	

NOT SHOWN:

FOOTNOTES:

I. IF REPLACING STROBE LIGHT 217-108 USE KIT 190-2630.

NOTE:

HEAD FIRST GENERATION

REF NO.	PART NUMBER	QTY	DESCRIPTION	REMARKS
1	300-4132	1	PIVOT HEAD ASSEMBLY	
2	115-003	3	ZERK (1/4-NF, STR)	
3	115-002	2	ZERK (02N90)	
4	105-856	2	BOLT (1/4-NC X 1 1/4")	
5	155-153	1	CONNECTOR (06S-06S)	
6	158-1003	1	S/O COUPLER (64N-48H)	SEE FOOTNOTE 3
7	310-895	1	T-BOLT CLAMP (3")	SEE FOOTNOTE 4
8	154-255	2	UNION (040-040FX90)	SEE NOT SHOWN FOR HYD. HOSE
9	125-772	1	COMPOSITION BUSHING (1.5")	SEE FOOTNOTE 2
10	125-771	1	COMPOSITION BUSHING (1.25")	SEE FOOTNOTE 2
11	105-834	7	FLG LOCKNUT (3/8-NC)	
12	110-958	1	BACKUP PLATE	
13	149-136	1	HYD LOCKOUT VALVE	
14	159-931	1	CONNECTOR (06S-06SF)	
15	154-220	2	CONNECTOR (040-06S)	
16	115-511	1	KLIP RING (1.50")	
17	115-483	1	KLIP RING (1.250")	
18	154-342	1	CONNECTOR (06S-06090)	SEE NOT SHOWN FOR HYD. HOSE
19	177-002	7	SLEEVE	
20	300-4149	1	DEFLECTOR	
21	110-481	2	HOSE CLAMP	
22	300-4151	4	KNOB	
23	181-974	1	TAPERED INSERT (1.5")	
24	107-181	1	BOLT (5/8-NC X 1-1/4", GD8)	LOCTITE 242
25	179-812	1	TAPERED PIN (1.5" X 9.370")	
26	105-883	7	FLG LK BOLT (3/8-NC X 2")	
27	156-067	1	CONNECTOR (06S-060, ORF .031")	
28	300-4332	1	CLEAN OUT DOOR SEAL	USE 401 LOCTITE
29	300-4342	1	BACK PLATE	SEE FOOTNOTE 1
30	300-4343	1	STRAP	
31	300-9609	1	RETAINER PLATE	
32	149-675	1	CYL (2.5 X 1.25 X 10.0)	

NOT SHOWN:

150-1961 1 HOSE (060FX90-13"-3000)
150-1856 2 HOSE (040FX-240"-3000)

FOOTNOTES:

1. LOCKTITE SEAL TO THIS PART
2. INSTALL BUSING'S INTO CYLINDER BEFORE INSTALLING CYLINDER ONTO HEAD.
3. FOR 4" HOSE USE S/O COUPLER 157-863
4. FOR 4" HOSE USE T-BOLT CLAMP (4") 318-384

NOTE:

GREASE HOSES

800 GAL

ENDS WITH S/N: CMWFX30XEE0002089, CMWFX50XAE0000197, CMWFX60XVE0000852

REF PART

NO. NUMBER QTY DESCRIPTION REMARKS

REF PART NO.	NUMBER	QTY	DESCRIPTION	REMARKS
1	150-3214	1	HOSE (02NP-040FX-120"-3000-GREASE)	
2	150-3279	1	HOSE (02NP-040FX-113"-3000-GREASE)	
3	150-3279	1	HOSE (02NP-040FX-113"-3000-GREASE)	
4	150-3278	1	HOSE (02NP-040FX-70"-3000-GREASE)	
5	150-2984	1	HOSE (02NP-040FX-74.5"-3000-GREASE)	
6	150-3211	1	HOSE (02NP-040FX-77"-3000-GREASE)	
7	156-273	3	CONNECTOR (02N-04090)	
8	154-365	3	CONNECTOR (02N-040)	
9	154-255	3	UNION (040-040FX90)	
10	115-001	6	ZERK (02N)	
11	117-693	1	ABRASION SLEEVE (1.00" X 60")	
12	117-213	1	ABRASION SLEEVE (1.00" X 96")	
13	301-1348	1	BRACKET	
14	105-1526	1	CLAMP SET (17.2 MM)	
15	105-832	2	FLG LOCKNUT (1/4-NC)	
16	105-261	2	BOLT (1/4-NC X 1.5", SOC)	

NOT SHOWN:

FOOTNOTES:

NOTE:

REFER TO O-RING CHART (800-301) IN BACK OF BOOK FOR REPLACEMENT OF O-RINGS.

INNER TUBE

REF NO.	PART NUMBER	QTY	DESCRIPTION	REMARKS
1	300-4130	1	INNER TUBE ASSEMBLY	
2	300-4110	1	LINEAR ACTUATOR	SEE NOT SHOWN FOR SERVICE PART
3	105-065	1	LOCKNUT (1/2-NC)	
4	105-082	1	BOLT (1/2-NC X 2-1/2")	
5	105-242	3	BOLT (3/8-NC X 6-1/2")	
6	105-047	3	LOCKNUT (3/8-NC)	
7	300-4183	3	4" V-ROLLER	
8	105-118	6	WASHER (3/8")	

NOT SHOWN:

500-2155 ELECTRIC MOTOR, LINEAR ACTUATOR

FOOTNOTES:

NOTE:

FILTER PLUMBING W/ DECK MOUNT CANISTER

REF NO.	PART NUMBER	QTY	DESCRIPTION	REMARKS
1.	601-598	-	LID CAGE ASSEMBLY	
2.	310-895	5	T-BOLT CLAMP (3")	
3.	116-895	1	SUCTION HOSE (3",SOLD PER FT.)	USE 1 @ 104"
4.	110-128	1	SPRING CLIP PIN (5/32" X 1")	
5.	514-168	2	S/O COUPLER (48N-48H)	
6.	115-381	AR	BULK HOSE (1/4", SOLD PER 1")	USE 1 @ 120"
7.	115-300	1	NIPPLE (48N-4")	
8.	150-5298	1	RELIEF VALVE (2" NPT, 15 IN-HG)	FOOTNOTE 1
9.	153-345	1	NIPPLE (32N-3.5")	
10.	120-073	1	SHUT-OFF (12NF-12NF)	
11.	155-265	1	REDUCER (48N-32NF)	
12.	154-485	1	TEE (48NF-48NF-48NF)	
13.	117-814	AR	HOT AIR BLOWER BULK HOSE 3"	USE 1 @ 9"
14.	114-017	1	STREET ELBOW (48N-48NF90)	
15.	153-882	1	TEE (-48N-48H-04N)	
16.	153-497	1	ELBOW (40NF-40NF90)	
17.	153-496	1	NIPPLE (40N)	
18.	153-495	1	AIR PRE-FILTER	
19.	115-153	1	PLUG (04N, SQ)	FOOTNOTE 2
20.	115-130	1	TEE (04NF-04NF-04NF)	
21.	514-427	2	S/O COUPLER (040F-04H)	
22.	154-339	2	CONNECTOR (04N-040)	
23.	258-047	1	VACUUM PRESSURE GAUGE	
24.	214-817	1	3" SIGHT GLASS WITH O-RING	
25.	114-021	1	NIPPLE (12N-3-1/2")	
26.	110-249	2	WORM CLAMP (1/4" TO 5/8 ")	
27.	318-378	1	DRAIN ROD	
28.	316-474	1	DRAIN HANDLE	
29.	114-024	1	REDUCER (40N-32NF)	
30.	154-487	1	ELBOW (48NF-48NF90)	
31.	316-829	-	500 GAL TANK AND SKID	
32.	120-105	1	FILTER CANISTER	
33.	157-356	1	THREAD PROTECTOR (56NF)	
34.	107-478	1	WING NUT (1/2-NC)	
35.	107-652	2	NYLON WASHER	
36.	329-099	1	FILTER CANISTER LID	
37.	302-0724	1	WINGNUT COUPLER	
38.	195-1200	1	VAC FILTER	
39.	116-421	AR	BULK EDGE (1/8", SOLD PER 1')	USE 1 @ 63"
40.	105-834	2	FLG LOCKNUT (3/8-NC)	
41.	313-486	1	RETAINER	
42.	117-518	1	FLAP	
43.	105-884	2	WASHER (.531")	USE 2 OR AS REQUIRED

NOTE:

- 101-126 - FILTER CANISTER - INCLUDES REF #'S 2, 5, 8 THRU 12, 14 THRU 20, 24, 29, 32 THRU 37, 39 THRU 43, AND THE FOLLOWING PARTS WHICH ARE NOT SHOWN.
- 105-826 8 FLG LK BOLT (3/8-NC X 1")
- 115-104 1 NIPPLE (12N X 1-1/2")
- 310-301 1 HOLDER
- 316-961 1 MOUNTING BRACKET
- 364-325 1 ANTIFREEZE TANK (3 GAL)
- 514-161 1 S/O COUPLER (12N-12H)

FOOTNOTES

- DO NOT ADJUST
- FOR LONG TERM STORAGE, REMOVE PLUG & SPRAY LIGHT OIL THEN RUN FOR 1 TO 2 MINUTES AND REPLACE PLUG.

CLICK HERE TO **DOWNLOAD** THE COMPLETE MANUAL

- Thank you very much for reading the preview of the manual.
- You can download the complete manual from: www.heydownloads.com by clicking the link below



- Please note: If there is no response to CLICKING the link, please download this PDF first and then click on it.

CLICK HERE TO **DOWNLOAD** THE COMPLETE MANUAL

FILTER PLUMBING W/ SIDE MOUNT CANISTER
800 GALLON TANK
ENDS WITH S/N CMWFX60_____

REF NO.	PART NUMBER	QTY	DESCRIPTION	REMARKS
1.	325-343	-	PRIMARY SHUTOFF 12" LOW	
2.	120-188	-	SECONDARY SHUTOFF/FILTER CANIS	
3.	318-384	4	T-BOLT CLAMP (4")	
4.	120-138	AR	SUCTION HOSE (4")(SOLD PER FT)	USE 1 @ 85"
5.	120-138	AR	SUCTION HOSE (4")(SOLD PER FT)	USE 1 @ 155"
6.	105-830	4	FLG LK BOLT (1/2-NC X 1-1/4")	
7.	106-198	4	FLG LOCKNUT (1/2-NC, GD8)	
8.	300-4291	1	800 GALLON TANK	

NOT SHOWN:

FOOTNOTES:

NOTE:

CYCLONIC SEPARATOR 300/500/800 GALLON

BEGINS W/FX25_____, FX30_____, FX50_____, FX60_____

REF NO.	PART NUMBER	QTY	DESCRIPTION	REMARKS
1	318-384	2	T-BOLT CLAMP (4")	
2	301-5313	2	BRACE	
3	105-833	5	FLG LOCKNUT (1/2-NC)	
4	362-1503	1	CYCLONE GASKET	
5	120-138	1	SUCTION HOSE (4", SOLD PER IN)	QTY VARIES DEPENDING ON CONFIGURATION
6	499-543	1	HAND WHEEL	
7	301-2647	1	SIGHTGLASS RETAINING RING	
8	499-542	1	GLASS BOWL	
9	153-696	1	4" GASKET	
10	107-319	4	LOCKNUT (M14-2.0,PRV TRQ,10.9)	
11	107-318	4	SCREW (M14-2.00 X 60MM, 10.9)	
12	107-712	4	EYE BOLT	
13	107-713	4	WASHER	
14	107-714	4	WING NUT (5/8-NC)	
15	320-791	1	HINGED TANK LID	
16	115-110	1	PLUG (1/6N, SQ)	
17	106-740	1	SCREW (M16-2.00 X 150MM)	
18	106-545	1	LOCKNUT (M16-2.0,PRV TRQ,10.9)	
19	120-073	1	SHUT-OFF (1/2NF-1/2NF)	
20	115-163	1	ALL THREAD (1/2N) SCH 80	
21	149-513	1	STREET ELBOW (1/2N-1/2NF45)	
22	105-826	6	FLG LK BOLT (3/8-NC X 1")	
23	301-5269	1	FILTER MOUNT	
24	301-5316	1	CYCLONE	
25	300-6830	1	BACKER BAR	
26	106-194	11	FLANGE LOCKNUT (3/8-NC)	
27	301-0405	1	SPOILS RAKE	
28	108-132	4	FLG LK BOLT (3/8-NC X 2.5")	
29	301-4658	1	HORIZONTAL CYCLONE LID	USE VARIES BY CONFIGURATION
30	301-4659	1	VERTICAL CYCLONE LID	USE VARIES BY CONFIGURATION

NOT SHOWN:

FOOTNOTES:

NOTE:

POWER PAC FILTER PLUMBING

FX30/500

ENDS WITH S/N CMWFX30 _____, 500 GAL.

REF PART

NO.	NUMBER	QTY	DESCRIPTION	REMARKS
1	154-485	1	TEE (48NF-48NF-48NF)	
2	155-265	1	REDUCER (48N-32NF)	
3	153-345	1	NIPPLE (32N-3.5")	
4	153-446	1	NIPPLE (48N-10")	
5	154-487	1	ELBOW (48NF-48NF90)	
6	115-300	1	NIPPLE (48N-4")	
7	154-339	1	CONNECTOR (04N-040)	
8	150-5298	1	RELIEF VALVE (2" NPT, 15 in-hg)	
9	114-024	1	REDUCER (40N-32NF)	
10	157-356	1	THREAD PROTECTOR (56NF)	
11	310-895	1	T-BOLT CLAMP (3")	
12	153-495	1	AIR PRE-FILTER	
13	115-130	1	TEE (04NF-04NF-04NF)	
14	115-153	1	PLUG (04N, SQ)	
15	324-759	1	COUPLER WELDMENT	

NOT SHOWN:

FOOTNOTES:

NOTE:

ANTIFREEZE PLUMBING

REF NO.	PART NUMBER	QTY	DESCRIPTION	REMARKS
1.	364-325	1	ANTIFREEZE TANK (3 GAL)	
	110-707	1	TANK CAP (96NF)	
	190-053	1	POLY-PATCH TANK REPAIR KIT	
2.	310-301	1	HOLDER	
3.	105-834	3	FLG LOCKNUT (3/8-NC)	
4.	120-105	-	FILTER CANISTER	
5.	105-826	3	FLG LK BOLT (3/8-NC X 1.00")	
6.	115-104	1	NIPPLE (12N X 1-1/2")	
7.	120-073	2	SHUT-OFF (12NF-12NF)	
8.	514-161	1	S/O COUPLER (12N-12H)	
9.	110-026	2	WORM CLAMP (1/2" TO 1-1/4")	
10.	115-374	AR	BULK HOSE (3/4" SOLD PER 1")	USE 1@ 48"
11.	500-1289	1	BULKHEAD FITTING (3/4-14 NPT)	SEE FOOTNOTE 1
12.	323-285	1	ANTIFREEZE TANK MOUNT	
13.	108-132	4	FLG LK BOLT (3/8-NC X 2 1/2")	
14.	108-172	4	WASHER (1/2") ZP	
15.	106-194	4	FLG LOCKNUT (3/8-NC)	

NOT SHOWN:

FOOTNOTES:

1. HOLES MAY REQUIRE MODIFICATION FOR NEW FITTINGS.

NOTE:

TANK ASSEMBLY 300 GAL.
ENDS WITH S/N: CMWFX30XTE0002304
CMWFX50XPE0000243, CMWFX60XJE0000882

REF NO.	PART NUMBER	QTY	DESCRIPTION	REMARKS
1	324-985	1	TANK BASE	
2	362-1834	1	VAC WATER TANK (POLYETHYLENE, 300 GAL)	
3	357-261	1	FILLWELL (16")	
4	108-072	8	SCREW (#10-16 X 1.25", PAN PLPS)	
5	364-434	1	TANK CAP (16", VENTED)	
6	357-263	1	TANK CAP (4")	
7*	153-883	1	BK CONNECTOR (12NF, POLY)	
8	115-152	1	PLUG (12N, SQ FM)	
9	105-830	8	FLG LK BOLT (1/2-NC X 1-1/4")	
10	105-833	8	FLG LOCKNUT (1/2-NC)	
11	115-218	1	CROSS (12NF)	
12	115-163	4	ALL THREAD (12N) SCH 80	SEE FOOTNOTE 1
13	120-073	2	SHUT-OFF (12NF-12NF)	
14	153-197	3	STREET ELBOW (12N-12NF90)	
15	514-161	2	S/O COUPLER (12N-12H)	
16	115-123	1	TEE (12NF)	
17	154-351	1	CONNECTOR (12N-120)	
18	301-5551	1	LEVELING PLATE	
19	106-197	2	BOLT (1/2-NC X 2-1/2", GD8)	
20	108-172	2	WASHER (1/2") ZP	
21	105-885	2	FLG LK BOLT (1/2-NC X 2")	
22	106-198	4	FLG LOCKNUT (1/2-NC, GD8)	
23	322-628	2	TANK STRAP	USED ON TRAILER WHEN WATER TANK IS OFFSET

NOT SHOWN:

FOOTNOTES:

1. WHEN USING HEATER KIT, 115-152 PLUG IS REPLACED BY 115-126 REDUCER AND 213-069 TEMP SWITCH.

NOTE:

FRAME AND LIGHTS

BEGINS WITH S/N 7Y2231 / ENDS WITH S/N 701935

T18S

REF NO.	PART NUMBER	QTY	DESCRIPTION	REMARKS
1	105-047	4	LOCKNUT (3/8-NC)	
2	105-183	2	BOLT (3/8-NC X 2-1/2" ,GD8)	
3	206-351	1	JACK CRANK	
4	105-829	12	FLG LK BOLT (1/2-NC X 1")	
5	316-868	1	JACK EXTENSION	
6	217-003	4	GROMMET (M10, LAMP MOUNT)	
7	217-002	2	MKR/CLR LAMP (M10, AMBER)	
8	217-001	4	MKR/CLR LAMP (M10, RED)	
9	217-225	2	GROMMET (M60, LAMP MOUNT)	
10	217-224	2	S,T,T, LAMP (M60)	
11	110-129	1	REGISTRATION HOLDER	
12	110-449	3	POP RIVET (3/16" X .690")	
13	326-424	1	BATTERY COVER	
14	116-918	AR	GROMMET (3/4", RUBBER)	
15	107-121	4	LOCKNUT (5/8-18, GD-8)	
16	105-689	4	BOLT (5/8-NF X2-1/4", GD 8)	
17	217-018	AR	FEMALE CONNECTOR (6-WAY)	
18	214-610	1	BREAKAWAY SWITCH	
19	105-071	2	WASHER (1/2")	
20	105-830	5	FLG LK BOLT (1/2-NC X 1-1/4")	
21	105-686	5	SCREW (1/4-NC X 1", PAN TORX)	
22	215-412	1	LICENSE PLATE LAMP	
23	324-485	1	RIGHT HAND FENDER	
24	324-486	1	LEFT HAND FENDER	
25	308-924	1	12,000# BOLT ON JACK	
26	117-525	2	MUD FLAP	
27	105-833	16	FLANGE LOCKNUT (1/2-NC)	
28	214-537	2	MOUNT (M15, LAMP)	
29	217-263	2	AMBER LAMP (M15)	
30	105-687	4	SCREW (#10-24 X 3/4" PAN TORX)	
31	106-048	4	LOCKNUT (#10-24)	
32	105-825	2	FLG LK BOLT (3/8-NC X .75")	

NOT SHOWN:

FOOTNOTES:

NOTE:

TONGUE STORAGE BOX

T26 S

REF NO.	PART NUMBER	QTY	DESCRIPTION	REMARKS
1.	110-222	2	HOOD LATCH	
2.	105-085	2	LOCKNUT (1/4-NC)	
3.	105-823	2	FLG LK BOLT (5/16-NC X 3/4")	
4.	105-818	2	BOLT (1/4-NC X 1-1/2")	
5.	105-003	2	FLG LOCKNUT (5/16-NC)	
6.	110-503	2	PULL HANDLE	
7.	110-224	2	ANCHOR BRACKET	
8.	110-223	2	LATCH BRACKET	
9.	105-687	8	SCREW (#10-24 X 3/4", PAN TORX)	
10.	303-454	2	PIVOT STUD	
11.	105-310	4	JAM NUT (3/4-NC)	
12.	117-256	1	POWER SPRING (5/8 SHAFT)	
13.	303-330	2	HASP	
14.	319-717	1	LID	
15.	106-048	8	LOCKNUT (#10-24)	

NOT SHOWN:

FOOTNOTES:

NOTE:

SLIPPER SPRING

T18B, T18S

STARTS WITH S/N 7Y2105

REF NO.	PART NUMBER	QTY	DESCRIPTION	REMARKS
1	324-681	2	CENTER SPRING HANGER	
2	324-680	2	REAR SPRING HANGER	
3	324-679	2	FRONT SPRING HANGER	
4	205-486	2	8000# ELECTRIC DROP AXLE	SEE NOT SHOWN FOR AXLE TUBE REPLACEMENT AND LUGNUTS.
5	105-1232	8	U-BOLT (9/16"-18 x 8")	
6	105-1231	4	U-BOLT PLATE	
7	105-1229	16	U-BOLT NUT (9/16- UNF)	TORQUE TO 65-95 FT-LBS
8	105-1230	4	SLIPPER SPRING (4000 # CAPI)	
9	108-124	8	HANGER BOLT 9/16"-18 UNF X 3-1/2")	
10	108-125	8	HANGER LKNUT (9/16- UNF)	SEE FOOTNOTE I
11	205-493	2	EQUALIZER	
12	108-126	2	EQUALIZER BOLT (7/8-9 UNC X 4-11/16")	
13	108-127	2	CASTLE NUT (7/8- UNC)	
14	105-518	2	COTTER PIN (1.25 X 1.500)	
15	500-1594	4	SPRING BUSHING (9/16" ID X 2")	

NOT SHOWN:

205-1200 8K AXLE TUBE
106-066 AR LUGNUT (5/8-NF)

HEAVY DUTY REPLACEMENT AXLE, TUBE ONLY

FOOTNOTES:

I. NON SOULDERD TYPE BOLTS WITH 9/16" THREADS ARE SNUG FIT ONLY. PARTS MUST ROTATE FREELY. MUST USE A LOCKING NUT OR COTTER PIN.

NOTE:

DRUM AND HUB 12K DEXTER ELECTRIC T26S

REF NO.	PART NUMBER	QTY	DESCRIPTION	REMARKS
	206-547		6K HUB ASSEMBLY	BRAKE DRUM NOT INCLUDED.
1	157-675	1	OIL SEAL (4.50" OD X 3.125" ID)	
2	500-3317	1	BEARING CUP AND CONE	
3	206-529	1	BRAKE DRUM (I2 1/4" X 3 3/8")	
4	107-1002	8	DRUM MOUNTING BOLT	
5	107-464	8	DRIVE IN STUD (5/8"-NF)	
6	206-544	1	6K HUB	INCLUDES BEARING CUPS AND WHEEL STUDS
7	500-3318	1	BEARING CUP AND CONE	
8	500-3319	1	SPINDLE NUTS & WASHERS KIT	
9	190-1303	1	OIL CAP KIT	INCLUDES SCREW IN CAP, O-RING, & CAP PLUG.
	206-532	AR	OIL CAP PLUG	INCLUDED IN OIL CAP KIT
10	105-276	8	LUG NUT 5/8"-NF)	
11	502-173	1	WHEEL CLAMP RING	
12	205-1092	-	WHEEL (16 X 6WD W/8, HEAVY)	SEE FOOTNOTE 1

NOT SHOWN:

FOOTNOTES:

1. USED ON 205-462 T/N (235/85R 16G).

NOTE:

LIGHTLY GREASE STUDS AND TORQUE LUG NUTS TO 200 FT-LBS.

HYDRAULICS

POWER PACK HYDRAULICS

FX-30

REF NO.	PART NUMBER	QTY	DESCRIPTION	REMARKS
1.	154-729	1	HOSE (040FX90-44"-3000)	
2.	154-250	AR	CONNECTOR (040-06S45)	USE 2 WITH 500 AND 800 GAL, USE 1 WITH 1200 GAL
3.	154-355	2	BK CONNECTOR (040-04090BK)	
4.	215-2295	1	12 VDC POWER UNIT W/THERMAL SW	SEE FOOTNOTE 1,2 & 3 SEE NOTE 1
5.	105-873	2	FLG LK BOLT (5/16-NC X 1")	
6.	105-841	2	CLIP NUT (5/16-NC)	
7.	149-362	1	HOSE (040FX90S-46"-3000)	
8.	105-095	AR	WASHER (1/4")	
9.	105-825	2	FLG LK BOLT (3/8-NC X 3/4")	
10.	154-462	1	CONNECTOR (06N-04090)	USE WITH 1200 GAL ONLY

NOT SHOWN:

FOOTNOTES:

- BEGINS WITH SERIAL NUMBER _____
- ENDS WITH SERIAL NUMBER _____ SUPERCEDED BY 213-280.
- SEE PARTS PAGE ID0365602 (12 VDC POWER UNIT W/ THERMAL SW) FOR SERVICE PARTS.

NOTE:

- FILLER CAP 110-1005 IS SERVICE PART FOR DC POWER UNIT NUMBER 213-280

DIVERTER AND LOCKOUT VALVES

FOR HYD. BOOM OR DOOR

ENDS WITH S/N CMWFX30_____, CMWFX60_____, 800 GAL.

REF NO.	PART NUMBER	QTY	DESCRIPTION	REMARKS
1	158-1002	1	DIVERTER VALVE	SERVICE PARTS LISTED IN NOT SHOWN.
2	154-263	2	CONNECTOR (04S-04045)	SEE NOT SHOWN FOR HYD. HOSE'S
3	154-226	4	CONNECTOR (040-06S90)	
4	154-474	2	CONNECTOR (04S-04090, XL)	
5	106-378	2	FLG LK SCREW (M6-1.00 X 12MM)	
6	149-136	1	HYD LOCKOUT VALVE	
7	154-220	2	CONNECTOR (040-06S)	
8	154-379	2	UN BR TEE (040FX-040-040)	
9	105-832	2	FLG LOCKNUT (1/4-NC)	
10	105-198	2	BOLT (1/4-NC X 1-3/4")	

NOT SHOWN:

154-911	2	HOSE (040FX-36"-3000)
500-2031		COIL
500-2032		COIL CROWN

FOOTNOTES:

NOTE:

500 & 800 HYD. DOOR LIFT

ENDS W/CMWFX25 _____, CMWFX30 _____, CMWFX60 _____, 500G;
 CMWFX30 _____, CMWFX60 _____, 800G; CMWFX60 _____, 300G

REF PART

NO.	NUMBER	QTY	DESCRIPTION	REMARKS
1	105-916	2	WASHER (1.031")	
2	318-932	2	FINAL LINK	
3	318-931	2	PIN	
4	115-499	8	KLIP RING (1.000")	
5	318-933	2	INTERMEDIATE LINK	
6	179-409	1	PIN	
7	318-930	1	SPACER	
8	179-624	1	LOCKOUT PIVOT PIN	
9	179-421	1	PIN	
10	125-800	1	COMPOSITION BUSHING (1")	
11	125-772	1	COMPOSITION BUSHING (1.5")	
12	320-164	1	CYLINDER LATCH BRACKET	
13	117-035	1	TORSION SPRING	
14	115-503	1	KLIP RING (.750")	
15	115-584	1	TORSION SPRING	
16	320-163	1	CYLINDER LOCK	
17	149-797	1	CYL (2.5 X 1.25 X 5.0)	
18	105-1279	1	WASHER	
19	105-329	2	WASHER (1")	

NOT SHOWN:

FOOTNOTES:

NOTE:

HYDRAULIC CYLINDERS (2.5" X 1.25")

REF NO.	PART NUMBER	QTY	DESCRIPTION	REMARKS
	151-101	-	CYL (2.5 X 1.25 X 2.0)	SEE FOOTNOTES 1 & 2
1	152-034	1	CYLINDER BARREL (2.5 X 2.0)	
2	153-012	1	CYLINDER ROD (1.25 X 2.0)	
	151-084	-	CYL (2.5 X 1.25 X 2.5)	SEE FOOTNOTES 1 & 2
1	152-022	1	CYLINDER BARREL (2.5 X 2.5)	
2	153-005	1	CYLINDER ROD (1.25 X 2.5)	
	151-055	-	CYL (2.5 X 1.25 X 3.0)	SEE FOOTNOTES 1 & 2
1	152-005	1	CYLINDER BARREL (2.5 X 3.0)	
2	150-435	1	CYLINDER ROD (1.25 X 3.0)	
	151-028	-	CYL (2.5 X 1.25 X 4.0)	SEE FOOTNOTES 1 & 2
1	150-283	1	CYLINDER BARREL (2.5 X 4.0)	
2	150-415	1	CYLINDER ROD (1.25 X 4.0)	
	149-797	-	CYL (2.5 X 1.25 X 5.0)	SEE FOOTNOTES 1 & 2
1	149-810	1	CYLINDER BARREL (2.5 X 5.0)	
2	150-423	1	CYLINDER ROD (1.25 X 5.0)	
	151-061	-	CYL (2.5 X 1.25 X 6.0)	SEE FOOTNOTES 1 & 2
1	152-010	1	CYLINDER BARREL (2.5 X 6.0)	
2	150-438	1	CYLINDER ROD (1.25 X 6.0)	
	151-045	-	CYL (2.5 X 1.25 X 8.0)	SEE FOOTNOTES 1 & 2
1	150-295	1	CYLINDER BARREL (2.5 X 8.0)	
2	150-427	1	CYLINDER ROD (1.25 X 8.0)	
	149-675	-	CYL (2.5 X 1.25 X 10.0)	SEE FOOTNOTES 1 & 2
1	150-692	1	CYLINDER BARREL (2.5 X 10.0)	
2	149-730	1	CYLINDER ROD (1.25 X 10.0)	
	151-180	-	CYL (2.5 X 1.25 X 12.0)	SEE FOOTNOTES 1 & 2
1	152-015	1	CYLINDER BARREL (2.5 X 12.0)	
2	150-418	1	CYLINDER ROD (1.25 X 12.0)	
3	150-773	1	CYLINDER HEAD (2.5 X 1.25)	
4	150-779	1	LOCK RING (2.5)	
5	150-776	1	CYLINDER PISTON (2.5 X 1.25)	
6	106-097	1	FLG BOLT (5/8-NC X 1-3/4",GD8)	SEE FOOTNOTE 3
7	500-031	1	O-RING (228 D90)	
8	157-021	1	BACKUP RING (228 D90)	
9	157-541	1	U-SEAL (1.250")	
10	157-538	1	WIPER SEAL (1.250")	
11	125-775	1	WEAR RING	
12	157-535	1	BACKUP RING (139 D90)	
13	157-019	1	O-RING (139 D90)	

NOT SHOWN:

259-100	U-SEAL INSTALLER (1" - 1.499")
259-236	WIPER INSTALLER (1.25")
259-242	PISTON SEAL INSTALLER (2.5")
259-243	PISTON INSTALLER (2.5")
259-188	CYL HEAD SPANNER - TWO PIN

FOOTNOTES:

- REF. #1 & #2 ARE SPECIFIC TO EACH CYLINDER, REF #3 THRU #13 ARE COMMON FOR ALL THE ABOVE LISTED CYLINDERS.
- SEAL REPAIR KIT P/N: 190-166
- APPLY LOCTITE 277 OR EQUIVALENT, TORQUE TO 180-200 FT-LBS

NOTE:

COMPONENTS

FX30 w/ 800 GAL VAC TANK & T18S TRAILER

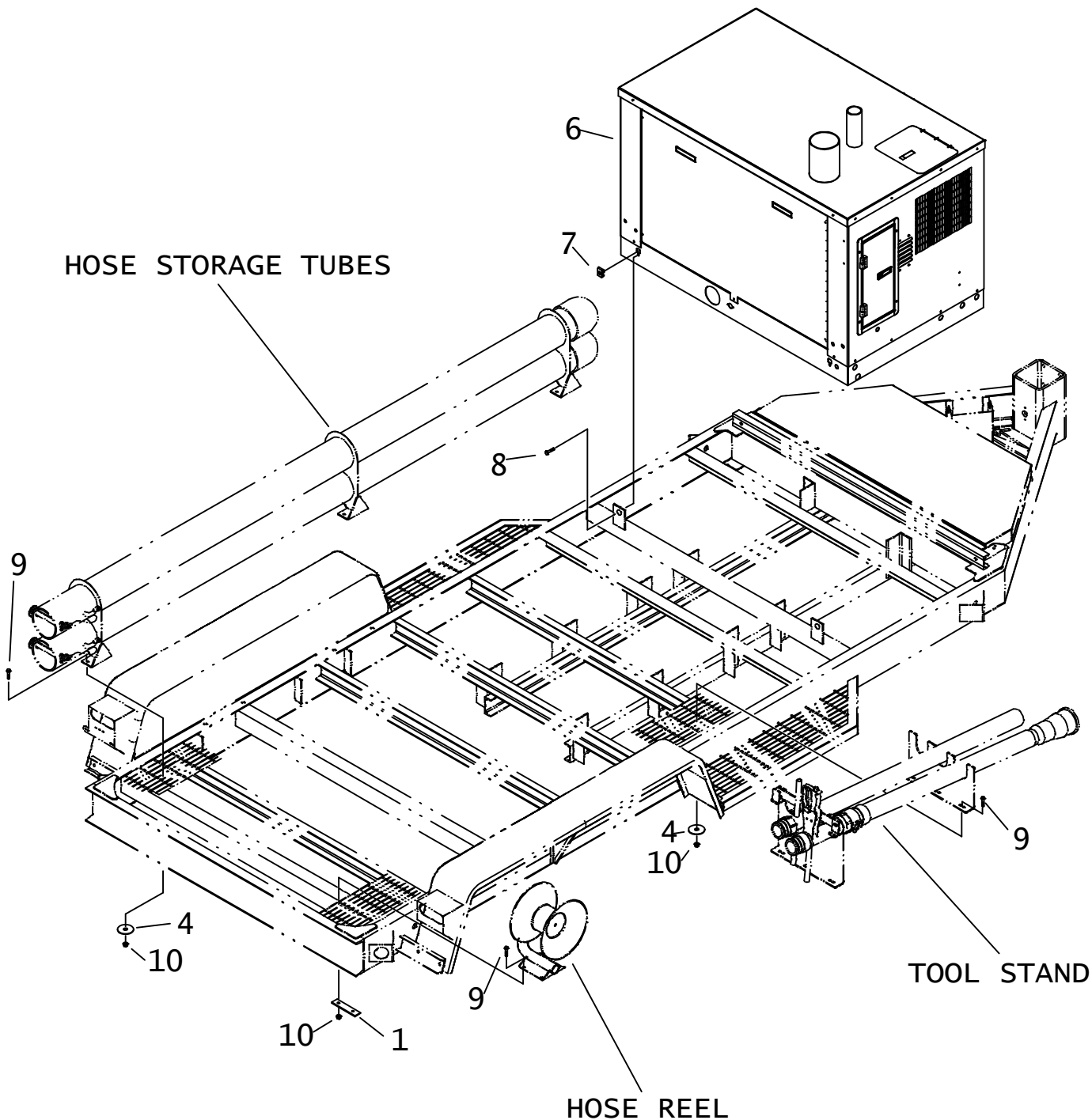

ELECTRICAL SCHEMATIC

FX30T4i POWER PACK

BEGINS WITH S/N CMWFX30XV80000547, 800 GAL

BEGINS WITH S/N CMWFX30XC80000546, 500 GAL

COMPONENT DESCRIPTIONS

REF NO.	PART NO.	COMPONENT	NOTES
B1	194-873	Starter	12V 1.4kw
B2	213-1001	DC Power Pack	
B3	300-4110	Linear Actuator	
BT1	215-244	Battery	
D1	215-1211	Diode	
D2	211-299	Diode	
D3	211-299	Diode	
D4	215-1140	Diode	Option
D5	215-1140	Diode	Option
D6	215-1140	Diode	Option
DS1	220-664	Oil Pressure Indicator	270-1937 Decal
DS2	220-664	Coolant Temp Indicator	270-1937 Decal
DS3	220-664	Glow Plug Indicator	270-1937 Decal
DS4	214-935	Gauge Panel Light	
DS5		Strobe	
DS6		Aux Work Light	
E1	see notes	DC Power Pack Pendant	Part of 213-1001
E2		Boom Pendant	Boom Option
E3	214-301	Accessory Socket	
F1	211-1000	Primary Fuse	80A
F2	211-295	Starter Solenoid Fuse	30A
F3	211-295	Glow Plug Fuse	30A
F4	211-294	Accessory Fuse	25A
F5	211-293	Ignition Fuse	20A
F6	211-289	Start Fuse	3A
F7	211-310	Boom Fuse	60A (Boom Option)
G1	195-1265	Alternator	12V 40A
HR1-3	see notes	Glow Plugs	No CMW part; Kubota 16065-65510

ELECTRICAL SCHEMATIC

T9S

100--TRAILER CIRCUIT

REF.	DESCRIPTION	WIRE DESCRIPTION	NOTES
101	TRAILER CONNECTOR-6 WAY	1 WHT, 2 BRN, 3 YEL, 4 GRN, 5 BLK	
102	BATTERY	1 WHT, 6 BLK	
103	BREAKAWAY SWITCH	5 BLK, 6 BLK	
104	LEFT BRAKE COILS	1 WHT, 5 BLK	
105	RIGHT BRAKE COILS	1 WHT, 5 BLK	
106	LEFT MARKER LIGHTS	1 WHT, 2 BRN	
107	RIGHT MARKER LIGHTS	1 WHT, 2 BRN	
108	3 MARKER LIGHT BAR	1 WHT, 2 BRN	
109	LEFT TAIL/TURN/STOP LIGHT	1 WHT, 2 BRN, 3 YEL	
110	RIGHT TAIL/TURN/STOP LIGHT	1 WHT, 2 BRN, 4 GRN	
111	TAG LIGHT	1 WHT, 2 BRN	

ELECTRICAL DIAGRAM

T26S

REF NO.	PART NUMBER	QTY	DESCRIPTION	REMARKS
	214-996		T26S 1200 GAL TRAILER HARNESS	
1.	217-002	-	MKR/CLR LAMP (M10, AMBER)	SEE FOOTNOTE 1
2.	194-235	-	MOTOR STARTER (SOLENOID SWIT)	
3.	217-224	-	S,T,T LAMP (M60)	SEE FOOTNOTE 2
4.	217-001	-	MKR/CLR LAMP (M10, RED)	SEE FOOTNOTE 1
5.	217-281	-	MKR/CLR LAMP (M35, RED, LED)	
6.	163-198	-	MAGNET KIT,12K LBS.	
7.	217-013	-	MALE CONNECTOR (6-WAY)	
	190-939	AR	CONNECTOR CORD KIT	SEE FOOTNOTES 3,4,5
8.	215-031	-	BREAKAWAY SWITCH	
9.	215-256	-	BATTERY	
10.	215-412	-	LICENSE PLATE LAMP	
11.	214-603	AR	CONNECTOR CORD (6-WAY)	
12.	214-931	-	MKR/CLR LMP M35, AMB,LED COMBO	
13.	214-209	-	2-WAY MALE CAP	
14.	214-103	-	(2-WAY) MALE CONNECTOR	
15.	157-783	-	VALVE	OBSOLETE
16.	213-042	1	1200 GAL TNK LIGHT HARNESS	

NOT SHOWN:

FOOTNOTES:

- FOR REPLACEMENT OF M10 LAMP PLUG USE 215-631.
- FOR REPLACEMENT OF M60 LAMP PLUG USE 217-226
- CONNECTOR KIT INCLUDES: 2X 105-686 (SCREW, 1/4-NC X 1, PAN HD TORX), 1X 217-013 (MALE CONNECTOR, 6-WAY) & 1X 217-018, (FEMALE CONNECTOR, 6-WAY).
- KIT IS USED TO CREATE A CONNECTOR CORD BETWEEN TRAILER & TOW VEHICLE USING 30" SECTION CUT FROM ORIGINAL HARNESS.
- FEMALE CONNECTOR MOUNTS TO PRE-DRILLED HOLES ON TONGUE GUSSET.

NOTE:

3" & 4" HOSE AND TOOL RACK

BEGINS W/CMWFX25 _____, CMWFX30 _____, CMWFX60 _____, 500G;
 CMWFX30 _____, CMWFX60 _____, 800G; CMWFX60 _____, 300G

REF PART

NO. NUMBER QTY DESCRIPTION REMARKS

REF PART NO.	NUMBER	QTY	DESCRIPTION	REMARKS
1	301-3713	2	TOOL RACK (3" AND 4" TOOL)	
2	301-3711	2	TOOL LATCH (3" AND 4" TOOL)	
3	301-3724	2	HOSE BRACKET	
4	105-1291	2	SPRING BUCKLE STRAP .75" WIDE	
5	105-826	4	FLG LK BOLT (3/8-NC X 1")	
6	108-132	8	FLG LK BOLT (3/8-NC X 2.5")	
7	108-172	8	WASHER (1/2") ZP	
8	106-194	12	FLANGE LOCKNUT (3/8-NC)	
9	110-368	2	SNAPPER PIN (3/8" X 1-1/2")	
10	106-210	2	BOLT (1/2-NC X 3")	USED WITH VAC BOOM OPTION
11	105-865	1	BOLT (1/4-NC X 3/4", GD8)	USED WITH VAC BOOM OPTION
12	105-833	2	FLG LOCKNUT (1/2-NC)	USED WITH VAC BOOM OPTION
13	110-239	1	LANYARD CABLE (13.5")	USED WITH VAC BOOM OPTION
14	105-085	1	LOCKNUT (1/4"-NC)	USED WITH VAC BOOM OPTION
15	153-915	1	FHC PLUG (-64)	USED WITH VAC BOOM OPTION, USES 153-255 W/3" OPTION
16	300-4296	1	4" HOSE BRACKET	USED WITH VAC BOOM OPTION

NOT SHOWN:

FOOTNOTES:

NOTE:

VAC TANK HOSE INLET KIT

REF NO.	PART NUMBER	QTY	DESCRIPTION	REMARKS
	190-1944		VAC TANK HOSE INLET KIT	INCLUDES ITEMS: 1-9
1	105-1511	2	T-BOLT CLAMP (5.44-5.75)	
2	302-1862	1	PIVOT HEAD ASSEMBLY	
3	302-1863	1	HOSE MOUNT	
4	106-248	6	SCREW (M10-1.50 X 150MM)	
5	105-894	6	LOCKNUT (M10-1.50, PRV TRQ, 10.9)	
6	105-1997	1	FHC BODY (80-80H)	USE CAM LOCK GASKET 500-3270
7	150-2601	53	SUCTION HOSE (5" AR, SOLD PER IN)	USE 53"
8	105-1998	1	FHC ADAPTER (80-80NPT-F)	
9	150-4884	1	REDUCER (5"OD X 4"OD) TUBE	

NOT SHOWN:

FOOTNOTES:

NOTE:

OPTIONS (3")

REF NO.	PART NUMBER	QTY	DESCRIPTION	REMARKS
1.	110-1018	4	GRIP (1", BLACK)	
2.	110-348	6	POP RIVET (3/16" X .664")	
3.	310-243	1	VACUUM HANDLE	
4.	166-360	2	FHC ADAPTER (48-48N)	
5.	259-491	1	ABS TUBING	
6.	259-490	1	ABS TUBING	
7.	315-651	1	7' SUCTION TOOL	
8.	315-652	1	10' SUCTION TOOL	

NOT SHOWN:

FOOTNOTES:

1: USE LOCKTITE 567 OR EQUIVALANT THREAD SEALANT ON ALL FITTINGS EXCEPT ORS FITTINGS

NOTE:

HEATER PLUMBING**T9S TRAILER****ENDS W/CMWFX25_____ , FX30_____ , 500G; FX60_____ , 300G.**

REF PART NO.	NUMBER	QTY	DESCRIPTION	REMARKS
	191-207	1	WATER HEATER KIT	
1.	194-287	1	WATER HEATER	INCLUDES REF. NO.S 2 THRU 26
2.	105-089	6	LOCKNUT (5/16-NC)	
3.	106-168	2	FLG LK BOLT (1/4-NC X 3/4")	
4.	106-076	4	WASHER (1/4")	
5.	105-085	2	LOCKNUT (1/4-NC)	
6.	115-153	2	PLUG (04N, SQ)	
7.	499-624	1	FUEL FILTER	
	499-625	1	FUEL FILTER ELEMENT	
8.	115-686	AR	BULK EDGE (5/32", SOLD PER 1")	USE 2 @ 7"
9.	107-826	3	CONDUIT FITTING (08N)	
10.	106-176	2	CONDUIT LOCKNUT (08N)	
11.	105-094	18	BOLT (5/16-NC X 1")	
12.	105-091	12	LOCK WASHER (5/16")	
13.	105-117	24	WASHER (5/16")	
14.	153-883	1	BK CONNECTOR (12NF, POLY)	
15.	315-552	1	HEATER SUPPORT	
16.	319-405	2	SIDE PANEL	
17.	110-249	6	WORM CLAMP (1/4" TO 5/8")	
18.	499-626	1	ELECTRICAL BOX	
19.	106-048	4	LOCKNUT (#10-24)	
20.	115-381	AR	BULK HOSE (1/4", SOLD PER 1")	USE 1 @ 36"
21.	106-049	4	BOLT (#10-24 X 3/4", PLPS)	
22.	499-627	1	CONTROL RELAY	
23.	107-268	2	SCREW (M4-0.70 X 20MM, SOC)	
24.	106-956	2	NUT, NYLON M4 X .7 PITCH	
25.	499-623	1	ROCKER SWITCH	
26.	499-621	1	THERMOSTAT (86F-194F)	
27.	105-883	4	FLG LK BOLT (3/8-NC X 2")	
28.	105-827	5	FLG LK BOLT (3/8-NC X 1-1/4")	
29.	320-432	2	TANK STRAP	
30.	320-275	2	HEATERSTAND (500 GAL)	
31.	155-007	1	UNION (3/4NPTX3/8NPTX90)	
32.	153-460	1	QDC ADAPTER (06-06N)	
33.	117-792	2	ABRASION SLEEVE (1.00" X 115")	
34.	154-816	2	HOSE (060FX-120"-3000)	
35.	514-077	2	CONNECTOR (06N-060)	
36.	514-085	1	REDUCER (08N-06NF)	
37.	514-355	1	CONNECTOR (04NF-04NF90)	
38.	105-826	4	FLG LK BOLT (3/8-NC X 1")	
39.	108-172	8	WASHER (1/2")	
40.	105-884	4	WASHER (.531")	

NOT SHOWN:

FOOTNOTES:

NOTE:

CLICK HERE TO **DOWNLOAD** THE COMPLETE MANUAL

- Thank you very much for reading the preview of the manual.
- You can download the complete manual from: www.heydownloads.com by clicking the link below



- Please note: If there is no response to CLICKING the link, please download this PDF first and then click on it.

CLICK HERE TO **DOWNLOAD** THE COMPLETE MANUAL