

TOOLS AND ACCESSORIES

CHOPPER

KNIVES.....	4U.36.1
V-BELT.....	4U.36.2
BISO-STRAW CHOPPER BASIS FRAME.....	4U.36.51
BISO-STRAW CHOPPER FLAIL DRUM WITH BEARING.....	4U.36.52
BISO-STRAW CHOPPER DISTRIBUTOR BOX.....	4U.36.54
BISO-STRAW CHOPPER DISTRIBUTOR BOX REGULATION ELECTRIC.....	4U.36.55
BISO-STRAW CHOPPER MOUNTING FRAME.....	4U.36.57
BISO-STRAW CHOPPER DEFLECTOR SHEETS.....	4U.36.58
BISO-STRAW CHOPPER GUARDS HOOD CROSS-STRUTS.....	4U.36.60
BISO-STRAW CHOPPER LAYSHAFT SUPPORT - 7070.....	4U.36.61
BISO-STRAW CHOPPER LAYSHAFT SUPPORT + 7071.....	4U.36.62
BISO-STRAW CHOPPER LAYSHAFT / CLUTCH - 7070.....	4U.36.63
BISO-STRAW CHOPPER LAYSHAFT + 7071.....	4U.36.64
BISO-STRAW CHOPPER EL.MAGNET CLUTCH "S"-VERSION - 7070.....	4U.36.66
BISO-STRAW CHOPPER VEE BELT CLUTCH + 7071.....	4U.36.67
BISO-STRAW CHOPPER STRAW WARNING SYSTEM.....	4U.36.68
BISO-STRAW CHOPPER ELECTRICAL EQUIPMENT.....	4U.36.69
CONVERSION KIT CHOPPER VEE BELT CLUTCH BISO-STRAW CHOPPER.....	4U.36.70
CONVERSION KIT CHOPPER VEE BELT CLUTCH BISO-STRAW CHOPPER.....	4U.36.71
CONVERSION KIT CHOPPER VEE BELT CLUTCH BISO-STRAW CHOPPER.....	4U.36.72
BISO-STRAW CHOPPER CHAFF SPREADER W.....	4U.36.73
BISO-STRAW CHOPPER CHAFF SPREADER W.....	4U.36.74
BISO-STRAW CHOPPER CHAFF SPREADER - 6170 / W.....	4U.36.75
BISO-STRAW CHOPPER CHAFF SPREADER W.....	4U.36.76
KPAB-STRAW CHOPPER BASIS FRAME -Y 05147.....	4U.36.77
KPAB-STRAW CHOPPER BASIS FRAME +Y 05148.....	4U.36.78
KPAB-STRAW CHOPPER DISTRIBUTOR BOX -Y 05147.....	4U.36.79
KPAB-STRAW CHOPPER DISTRIBUTOR BOX +Y 05148.....	4U.36.80
KPAB-STRAW CHOPPER DISTRIBUTOR BOX REGULATION ELECTRIC / W.....	4U.36.81
KPAB-STRAW CHOPPER MOUNTING FRAME.....	4U.36.82
KPAB-STRAW CHOPPER MOUNTING FRAME TENSION ROLLER +Y 005542 -Y 06439.....	4U.36.83
KPAB-STRAW CHOPPER GUIDE ROLLERS +Y 06440.....	4U.36.84
KPAB-STRAW CHOPPER DEFLECTOR SHEETS.....	4U.36.85
KPAB-STRAW CHOPPER LAYSHAFT -Y 05541.....	4U.36.87
KPAB-STRAW CHOPPER LAYSHAFT SUPPORT +Y 05542 -Y 06439.....	4U.36.88
KPAB-STRAW CHOPPER LAYSHAFT SUPPORT +Y 05542 -Y 06439.....	4U.36.89
KPAB-STRAW CHOPPER VEE BELT CLUTCH +Y 05542 -Y 06439.....	4U.36.90
KPAB-STRAW CHOPPER VEE BELT CLUTCH +Y 06440.....	4U.36.91
KPAB-STRAW CHOPPER BASIS FRAME FOR TYPE SRX ONLY.....	4U.36.92
KPAB-STRAW CHOPPER DISTRIBUTOR BOX FOR TYP SRX ONLY.....	4U.36.93

CLICK HERE TO **DOWNLOAD** THE COMPLETE MANUAL

- Thank you very much for reading the preview of the manual.
- You can download the complete manual from: www.heydownloads.com by clicking the link below



- Please note: If there is no response to CLICKING the link, please download this PDF first and then click on it.

CLICK HERE TO **DOWNLOAD** THE COMPLETE MANUAL

BISO-STRAW CHOPPER DISTRIBUTOR BOX

Fig.	Code	QTY	Name
22.1	16023482	1	valve I-590 R/G 20,22-34,36
23	16018753	0	screw
24	16018755	2	lever
25	16018756	2	rod
26	16018758	2	tube
27	06215315	2	spring
28	01107117	0	washer 17
29	01138938	0	nut m 16 p.1.5
30	06214192	0	washer 8.4
31	16018759	2	knob
32	01132621	4	split pin 3.2 x 16
33	01107105	6	washer 10.5
34	01132634	2	split pin 3,2x 32 d94
35	01106451	2	split pin 4 x 25
36	06214280	2	washer 13 x 24 x 2.5
37	01112693	2	screw m 16 x 45, d933
38	16015388	2	sleeve
39	01127856	2	nut m 16, d985
40	16018662	1	bracket
41	06214135	4	screw m 8 x 20
42	01112824	4	nut m 8, d934
43	01102799	4	washer 8, d128
44	01107101	4	washer 8.4

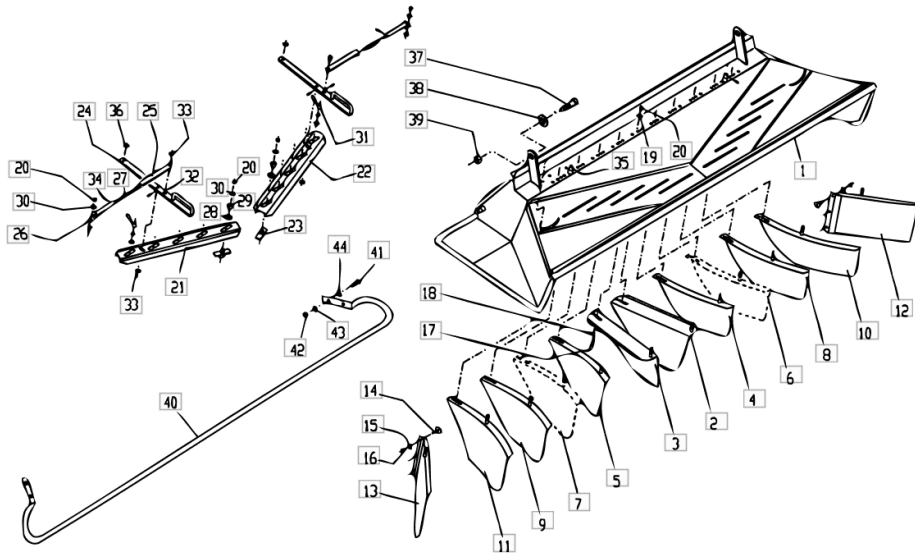

BISO-STRAW CHOPPER LAYSHAFT SUPPORT + 7071

Fig.	Code	QTY	Name
1	16023500	1	chassis frame
2	16019011	1	bracket
3	16019012	1	journal
4	01112322	1	screw m 8 p.1.25 x 20
5	01102799	1	washer 8, d128
6	01107101	1	washer 8.4
7	06214493	1	shim 40x50x1,0
14	16019014	1	support
30	16019016	2	mandrel
32	01112858	2	nut m 12, d934
33	01137252	1	nut bm12 d439
34	16019018	1	tensioner
37	01112560	1	screw m 12 x 50
38	01107289	4	washer b12 d137
39	06214280	1	washer 13 x 24 x 2.5
41	16018673	1	stop device G 41-44
42	01112886	8	nut m 16
43	01103952	4	spring disc
44	16019020	4	none
45	01112529	4	screw m 12 x 30, d933
46	01133726	2	washer 13
47	01102801	2	washer 12
48	01112858	6	nut m 12, d934
49	01112418	2	screw m 10 x 25, d933
50	01127717	2	washer 10.5
51	01102800	6	washer 10.2
52	01102659	6	nut m 10, d934
53	01112418	4	screw m 10 x 25, d933
54	01107105	4	washer 10.5

CONVERSION KIT CHOPPER VEE BELT CLUTCH BISO-STRAW CHOPPER

Fig.	Code	QTY	Name
38	01138686	0	shim 30x42x0,5
39	01122455	2	screw m 12 x 55
40	16027276	1	electric motor
41	16021661	1	top link
42	06272836	1	spring 6 x 35
43	06515118	1	disc
44	06233233	2	bushing 25 x 19 x 31
45	06302215	1	pin
46	16021662	1	support
47	16023426	1	washer 10,5 x 26
48	01102659	1	nut m 10, d934
49	01112456	1	screw m 10 x 50
50	16039163	4	nut m 12
51	16039164	1	chassis frame
52	16039165	1	bracket
53	01138811	3	screw m 12 x 30
54	16039166	1	bracket
55	01112687	2	screw m 16 x 40
56	01127856	2	nut m 16, d985
57	16039167	1	console
58	16039168	1	guide
59	01101846	1	screw m 10 x 70, d933
60	16023426	2	washer 10,5 x 26
61	16039169	1	spacer
62	06209768	1	nut m 10, d985
63	16039170	1	guide
64	16039171	1	console
65	16039172	1	guide
66	01137624	6	screw m 8 x 25
67	16023421	6	nut m 8
68	16023425	6	washer 8.4

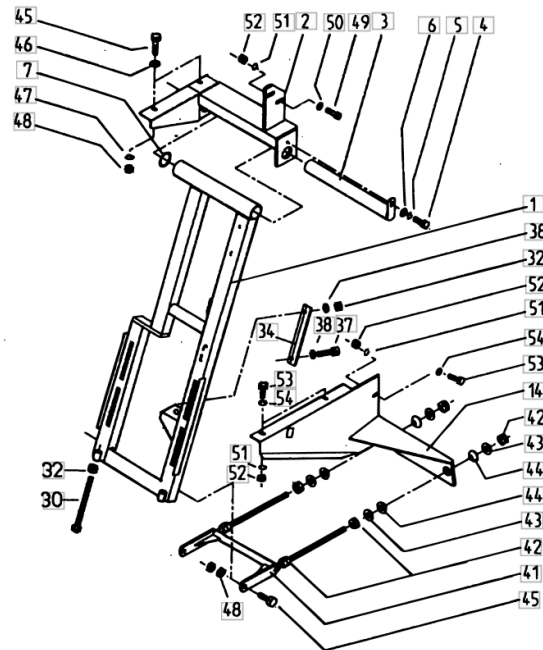
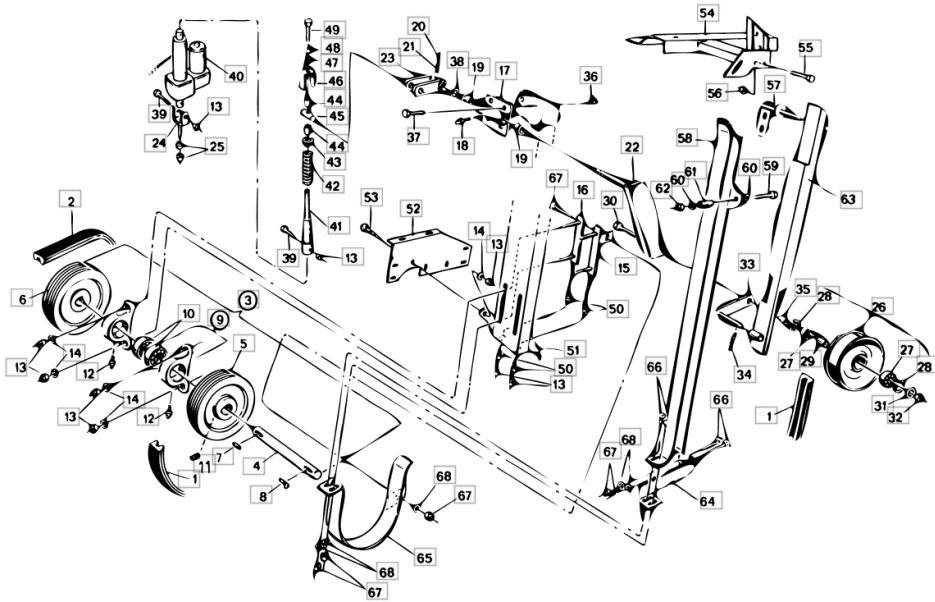

KPAB-STRAW CHOPPER BASIS FRAME -Y 05147

Fig.	Code	QTY	Name
			4075-4090
20	01108524	2	screw m 8 p.1.25 x 20
21	01112264	2	screw m 6 x 20, d933
22	16031416	2	washer 7x19
23	16020368	1	console
24	06262181	1	switch
25	16023420	6	nut m 12
26	16020369	1	console
27	01114357	2	nut m 6, d985
28	01139158	1	dowel 10x8x56 d6887
29	16020381	1	pulley d=200
30	01138811	10	screw m 12 x 30
31	16020382	1	rod
			4060/4065
31.1	16020387	1	rod
			4075-4090
32	16023039	1	roll pin
33	16020364	1	lever
			R
34	16020245	47	cutter
			4060/4065
34.1	16020245	58	cutter
			4075-4090
35	01112858	2	nut m 12, d934
36	01102801	2	washer 12
37	06209769	4	nut m 12, d985
38	16020373	2	bushing
39	16023424	2	washer 14x28
40	01122455	2	screw m 12 x 55
41	16020374	1	guard
42	06215786	4	box rb 45
43	01112307	16	screw m 8 p.1.25 x 15, d933
44	06215762	2	bearing
45	16020383	1	chassis frame
			4060/4065
45.1	16020388	1	chassis frame
			4075-4090

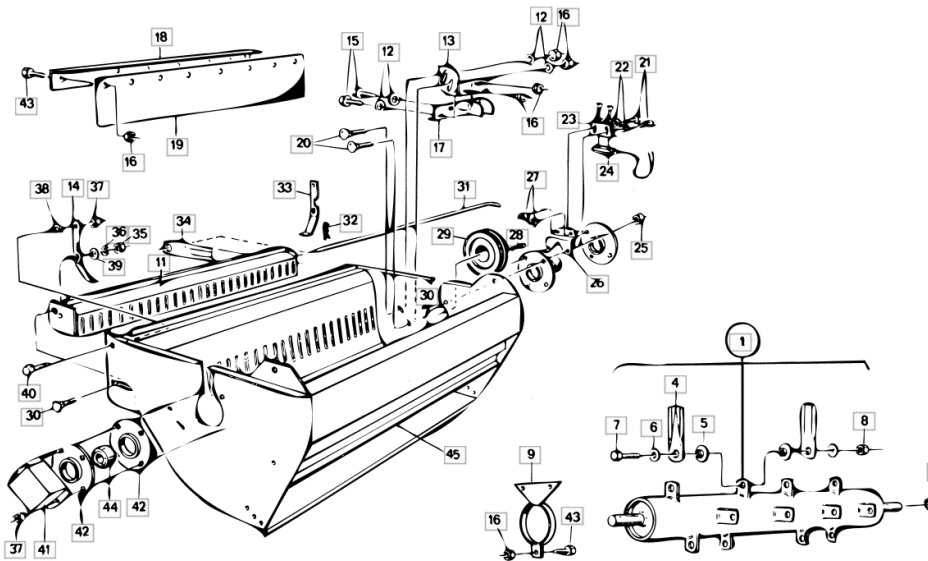

KPAB-STRAW CHOPPER DISTRIBUTOR BOX REGULATION ELECTRIC / W

Fig.	Code	QTY	Name
4	01104944	0	nut m 8, d985
5	16023425	0	washer 8.4
6	16039254	1	rail 4060-4068
6.1	16039271	1	rail 4075-4090
7	16039255	1	rubber plate 4060-4068
7.1	16039272	1	rubber plate 4075-4090
8	16039256	1	lamination 4060-4068
8.1	16039273	1	lamination 4075-4090
9	16039257	1	finger bar 4060-4068
9.1	16039274	1	metal strap 4075-4090
10	16039258	1	slider 4060-4068
10.1	16039275	1	slider 4075-4090
11	16039259	1	rail 4060-4068
11.1	16039276	1	metal strap 4075-4090
12	16039260	1	slider 4060-4068
12.1	16039277	1	slider 4075-4090
13	16039261	6	disc
16	01112326	8	screw m 8 x 22
17	16039262	1	valve -Y 06107 /4060/4065
17.1	16039263	1	valve +Y 06108 /4060-4068
17.2	16039278	1	valve -Y 06107 /4075-4090
17.3	16039279	1	valve +Y 06108 /4075-4090
18	16039264	2	washer
34	16023428	0	washer 9x28
45	01112307	14	screw m 8 p.1.25 x 15, d933
46	01112451	2	screw m 10 p.1.5 x 45

KPAB-STRAW CHOPPER LAYSHAFT -Y 05541

Fig.	Code	QTY	Name
1	16023026	2	shim
2	16023027	1	bracket
3	16023028	1	chassis frame -Y 05147
3.1	16023195	1	chassis frame +Y 05148
4	16023016	2	rod
5	16023017	2	tensioner
6	16023000	5	nut
7	01110577	2	screw m 8 x 25
8	16023425	4	washer 8.4
9	16023033	2	rail
10	16023421	4	nut m 8
11	16023193	2	bearing
12	06215761	2	bearing -Y 05147
12.1	06215746	2	ring yb 40 +Y 05148
13	16023422	6	nut m12 loc-king
14	16023427	16	washer 12,5 x 35
15	01137321	3	ring 40 x 2.5, d471
16	06214490	0	shim 40x50x0,1
17	06214491	0	shim 40 x 50 x 0,3
18	01112418	6	screw m 10 x 25, d933 -Y 05147
18.1	01112429	6	screw m 10 x 30, d933 +Y 05148
19	01145187	1	belt 2hbx7140
20	16023034	1	pulley d=225 -Y 05147 / 4075
20.1	16023198	1	pulley d=245 +Y 05148 / 4075
20.2	16023035	1	pulley d=245 -Y 05147 / 4080/90
20.3	16023199	1	pulley d=265 +Y 05148 / 4080/90
21	01107773	1	circlip 60x2 d471
22	16019091	0	shim 60x75x0,1
23	06214513	0	shim 60 x 75 x 0,2
24	16019051	2	bushing 60x75x2
25	01138887	2	ball bearing
26	16019052	1	bushing 75x95x2
27	16019053	4	spring
28	01107861	2	ring

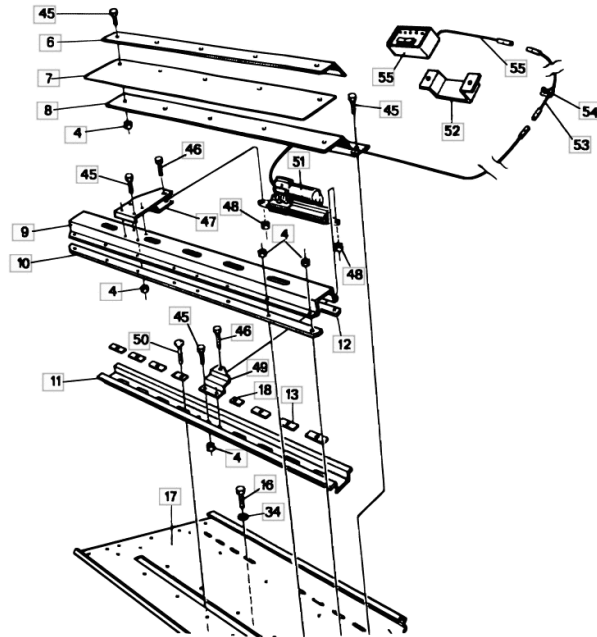
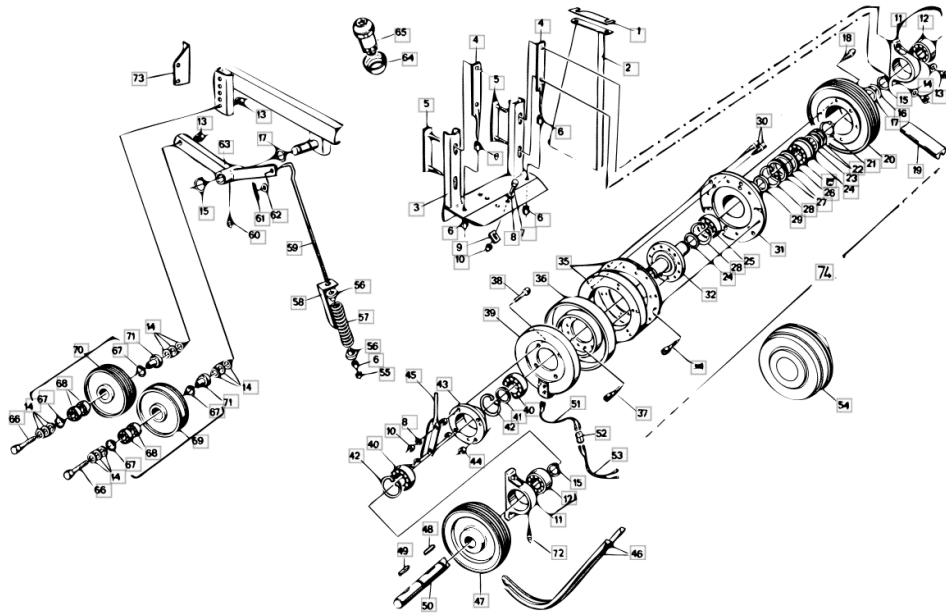

KPAB-STRAW CHOPPER BASIS FRAME FOR TYPE SRX ONLY

Fig.	Code	QTY	Name
39	16023427	2	washer 12,5 x 35
40	06209288	2	screw m 16 x 55
41	16055750	1	sump
42	16048759	2	bearing 50 vollst.
43	06207555	2	screw m 12 x 45
44	06215749	2	ball bearing 50
45	16055972	1	chassis frame 4060 - 4068
46	01120695	2	lubricator 1/8" d71412
47	01112407	12	screw m 10 x 20, d933
48	06209768	12	nut m 10, d985
49	16023426	12	washer 10,5 x 26
50	16023186	1	frame 4060 - 4068
53	16039122	1	consolle
54	16039123	1	sump
55	16039105	2	handle
56	01107117	2	washer 17
57	01127856	2	nut m 16, d985
58	NE	0	lamination
59	NE	0	lamination
60	NE	0	lamination

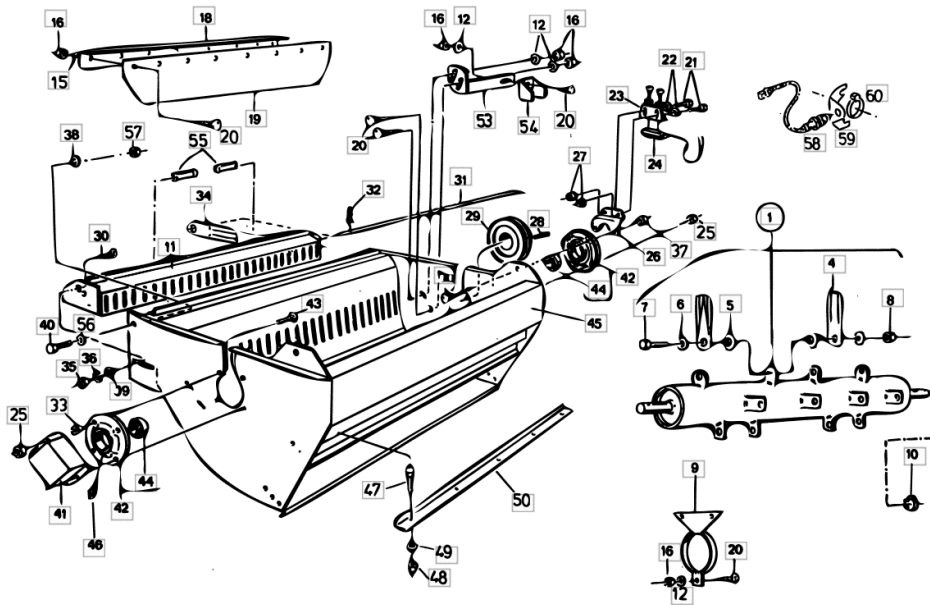

CONVERSION KIT CHOPPER VEE BELT CLUTCH KPAB-STRAW CHOPPER

Fig.	Code	QTY	Name
0.1	16039054	1	parts set
1	01145479	1	belt 2hc x 3270
2	01145187	1	belt 2hb x 7140
3	16039068	1	transmission
			4060 - 4075
3.1	16039069	1	transmission
			4080 / 4090
4	16039150	1	shaft
5	16039151	1	pulley Ø 260
6	16039152	1	pulley d=286
			4060 - 4075
6.1	16039153	1	pulley d=312
			4080 / 4090
7	06212458	1	dowel 10 x 8 x 50
8	01118268	1	dowel 10 x 8.0 x 63, d6887
9	16023193	2	bearing
10	06215746	2	ring yb 40
11	06208998	4	pin m10x16-45h
12	01120695	2	lubricator 1/8" d71412
13	06209769	11	nut m 12, d985
14	16023427	7	washer 12,5 x 35
15	16039154	1	tensioner
16	16039155	1	tensioner
17	16039156	1	support
18	01120693	1	lubricator am 8 x 1
19	16039157	2	sleeve
20	01157336	1	pin 5 x 45
21	01115476	1	pin 8 x 45, d1481
22	16039158	1	support
23	16021672	1	lever
24	16006207	1	fork m 16
25	01112886	2	nut m 16
26	16039159	1	tensioner
27	01109115	2	ball bearing 6303 2rs
28	01107834	2	circlip 47 x 1.75
29	16039160	1	bushing
30	01111942	1	screw
31	01107117	1	washer 17
32	01127856	1	nut m 16, d985
33	16039161	1	support
34	01143003	1	split pin 3,2x 36 d94
35	16039162	1	bushing
36	06209768	4	nut m 10, d985

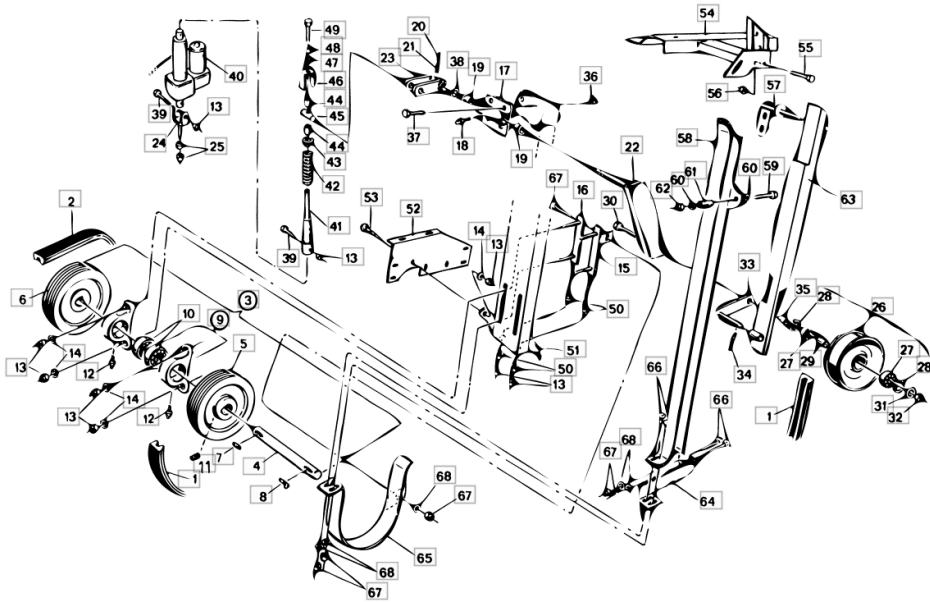

CLICK HERE TO **DOWNLOAD** THE COMPLETE MANUAL

- Thank you very much for reading the preview of the manual.
- You can download the complete manual from: www.heydownloads.com by clicking the link below



- Please note: If there is no response to CLICKING the link, please download this PDF first and then click on it.

CLICK HERE TO **DOWNLOAD** THE COMPLETE MANUAL