312C

Track-Type Excavator

Powered by 3064 Engine

SERIAL NUMBER

CAE1-01200(Vehicle)

6LK23357-Up(Engine)

CLICK HERE TO **DOWNLOAD** THE COMPLETE MANUAL

- Thank you very much for reading the preview of the manual.
- You can download the complete manual from: www.heydownloads.com by clicking the link below



- Please note: If there is no response to CLICKING the link, please download this PDF first and then click on it.

CLICK HERE TO **DOWNLOAD** THE COMPLETE MANUAL

INDEX

Name	Page	Name	Page
LINES GP - BOOM CYLINDER.....	278	MOUNTING GP - VALVE.....	400
LINES GP - BUCKET CYLINDER.....	281	MUFFLER GP.....	54
LINES GP - DRAIN.....	57		
	306	N	
	310		
LINES GP - ENGINE OIL.....	28	NOZZLE GP - UNIT INJECTOR.....	69
LINES GP - FRONT.....	344		
LINES GP - FUEL.....	66	P	
	68		
LINES GP - GREASE.....	567	PAN GP - OIL.....	25
LINES GP - HEATER.....	544	PANEL GP - CIRCUIT BREAKER.....	90
LINES GP - OIL DRAIN.....	32	PISTON & ROD GP.....	20
LINES GP - PILOT.....	320	PLATE & FILM GP.....	594
LINES GP - PUMP.....	314	PLATFORM GP - OPERATOR.....	509
LINES GP - QUICK COUPLER.....	295.01	PUMP & MOUNTING GP.....	243
	309.01	PUMP GP - FUEL INJECTION.....	69.01
LINES GP - RETURN.....	367.01	PUMP GP - MAIN HYDRAULIC.....	246
LINES GP - RETURN & FILTER.....	364	PUMP GP - WATER.....	43
	368		
LINES GP - STICK.....	290	R	
LINES GP - STICK CYLINDER.....	280		
LINES GP - SWING MOTOR.....	371	RADIATOR & HYD OIL COOLER GP.....	34
LINES GP - TRAVEL MOTOR.....	312	RADIO GP - AM.....	497
LINES GP - TURBOCHARGER OIL.....	31	RADIO GP - AM/FM.....	498
LINES GP - WATER.....	44	ROLLER AR - TRACK & CARRIER.....	222
LINK AS.....	515.01	ROLLER GP - TRACK CARRIER.....	224
LINK AS - TRACK.....	231	ROLLER GP - TRACK - SINGLE FLANGE.....	223
LINKAGE AR - BUCKET.....	551		
LINKAGE GP - BUCKET.....	569	S	
LITERATURE GP.....	527		
M		SCREEN GP.....	242
MANIFOLD GP - EXHAUST.....	59	SEAT BELT GP.....	524
MANIFOLD GP - INLET.....	58	SEAT GP.....	517
MIRROR GP - REAR VIEW.....	508	SIDECUTTER GP.....	587
MONITOR & MTG GP - OPERATOR.....	489	SPECIAL AR.....	11
MONITOR GP - OPERATOR.....	490	SPRING GP - RECOIL.....	220
MOTOR AS - WINDOW WIPER.....	485	SPROCKET GP - NONSEGMENTED.....	174
MOTOR GP - SWING.....	378	STARTING MOTOR GP - ELECTRIC.....	146
MOUNTING GP - ALTERNATOR.....	26	STICK AR - COUPLER.....	550.01
MOUNTING GP - ENGINE.....	27	STICK AR - HOE.....	550
MOUNTING GP - GREASE GUN.....	192		551
MOUNTING GP - STARTING MOTOR.....	145	STICK GP.....	561
		STICK GP - COUPLER.....	562.01
		STICK GP - HOE.....	558

BASIC ENGINE

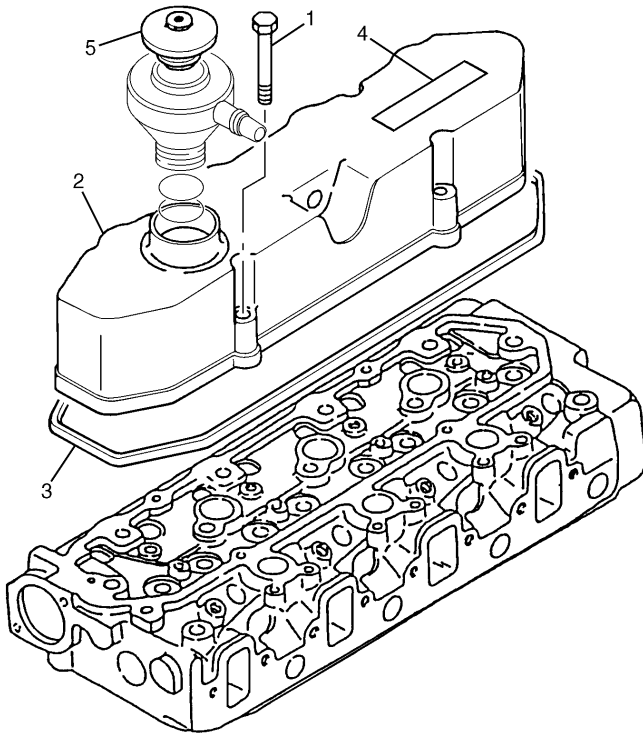

NOTE	No.	PART No.	QTY	PART NAME
	1	8T-4186	4	BOLT (L=40mm)
	2	51-7904	1	COVER
	3	51-7905	1	GASKET
	4	4P-6445	1	PLATE (CAT)
	5	51-7584	1	CAP

H78530E 01

196-8072 COVER GP-VALVE MECHANISM
Part of 162-6328-Page12

BASIC ENGINE

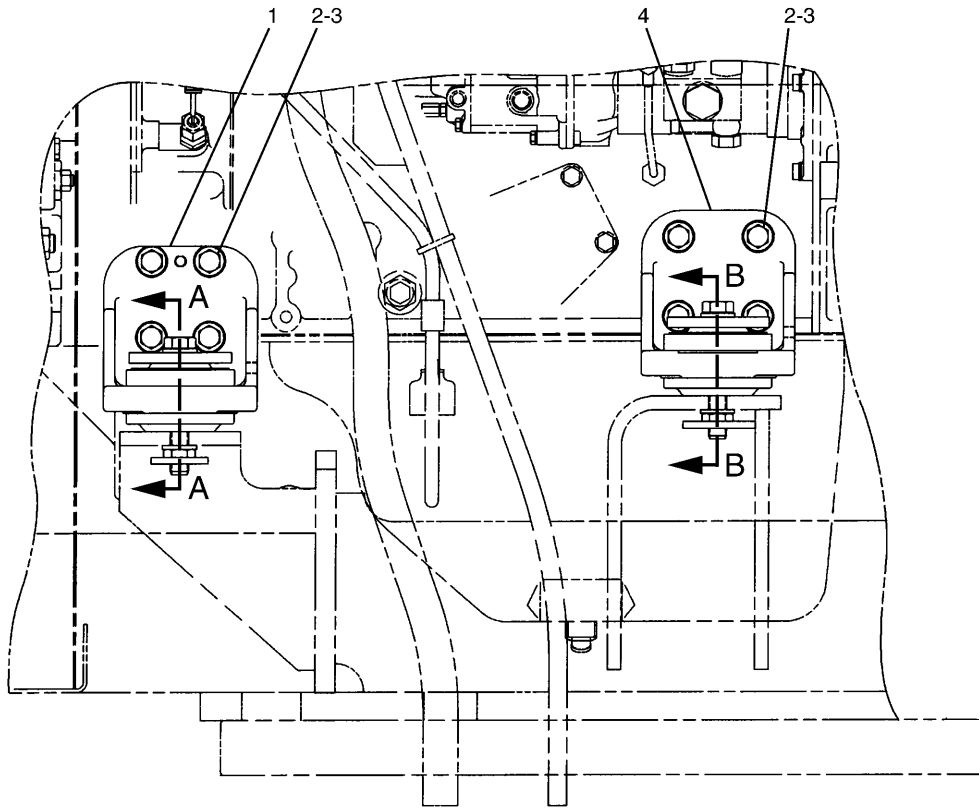

RIGHT SIDE VIEW ENGINE

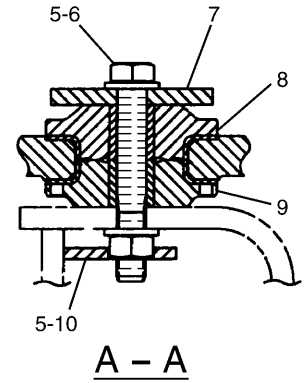

A - A

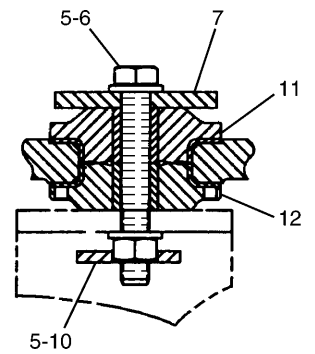

B - B

NOTE	No.	PART No.	QTY	PART NAME	NOTE	No.	PART No.	QTY	PART NAME
	1	178-6477	2	BRACKET					
	2	8T-4956	16	BOLT (L=35mm)					
	3	8T-4223	16	WASHER					
	4	118-9919	2	BRACKET					
	5	9X-8257	8	WASHER					
	6	8T-4173	4	BOLT (L=110mm)					
	7	099-4707	4	WASHER					
	8	118-9935	2	MOUNT					
	9	118-9936	2	MOUNT					
	10	118-9941	4	SUPPORT AS					
	11	193-2743	2	MOUNT					
	12	193-2744	2	MOUNT					

H71823E 01

162-6317 MOUNTING GP-ENGINE

COOLING SYSTEM

NOTE	No.	PART No.	QTY	PART NAME	NOTE	No.	PART No.	QTY	PART NAME
	1	193-2741	1	GUARD AS					
	2	8T-4984	4	CLAMP					
	3	190-5921	1	GUARD AS					
	4	7X-7729	11	WASHER					
	5	8T-4137	11	BOLT (L=20mm)					
Y	6	162-6332	1	RADIATOR GP					
	7	8T-4956	4	BOLT (L=35mm)					
	8	171-9164	1	HOSE					
	9	171-9165	1	HOSE					
	10	8T-4223	4	WASHER					
	11	8T-4224	2	WASHER					
	12	8T-4200	2	BOLT (L=16mm)					
	13	171-9077	1	BAND					
	14	096-0744	1	TANK AS					
		171-3369	1	CAP AS					
	15	096-0061	3	STRAP					
E	16	7Y-1976		HOSE...(39cm)					
	17	096-4035	1	CLIP					
D	18	5P-9909		SEAL...(0.6m)					

D—ORDER BY THE METER
 E—ORDER BY THE CENTIMETER
 Y—SEE SEPARATE ILLUSTRATION

H75096E 02

162-6331 RADIATOR & HYD OIL COOLER GP
 S/N CAE 1-(T01.01)
 162-6332-Page36

COOLING SYSTEM

NOTE	No.	PART No.	QTY	PART NAME	NOTE	No.	PART No.	QTY	PART NAME
	1	196-8031	1	CORE AS (RADIATOR)					
	2	096-4034	2	BOLT					
	3	8T-4189	16	BOLT (L=20mm)					
	4	8T-4224	16	WASHER					
	5	8T-4137	4	BOLT (L=20mm)					
	6	8T-4121	4	WASHER					
	7	124-1574	1	COCK AS					
E	8	7Y-1976		HOSE...(200cm)					
	9	178-6500	2	SEAL					
	10	196-8038	2	SEAL					
	11	196-8035	1	SCREEN AS					
	12	196-8047	1	FRAME AS					
	13	196-8037	2	SEAL					
	14	196-8034	1	SHROUD AS					
	15	184-3949	1	CAP AS					
	16	096-4035	2	CLIP					
	17	196-8046	1	CORE AS (OIL COOLER)					

E—ORDER BY THE CENTIMETER

H72107E 02

193-2878 RADIATOR & HYD OIL COOLER GP
 S/N CAE 1-(T01.01)
 Part of 193-2877-Page38
 An Attachment

AIR INLET AND EXHAUST SYSTEM

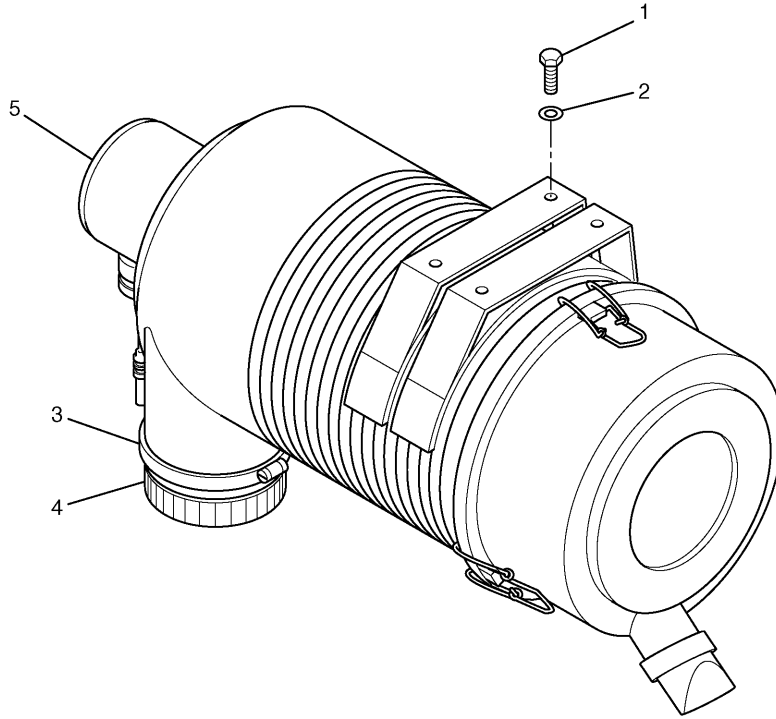

NOTE	No.	PART No.	QTY	PART NAME	NOTE	No.	PART No.	QTY	PART NAME
	1	8T-4200	4	BOLT (L=16mm)					
	2	8T-4224	4	WASHER					
	3	8T-6726	1	CLAMP					
	4	131-8915	1	CAP					
Y	5	118-9882	1	CLEANER GP					

Y-SEE SEPARATE ILLUSTRATION

H60738E 00

118-9881 AIR CLEANER GP
 118-9882-Page50
 An Attachment

AIR INLET AND EXHAUST SYSTEM

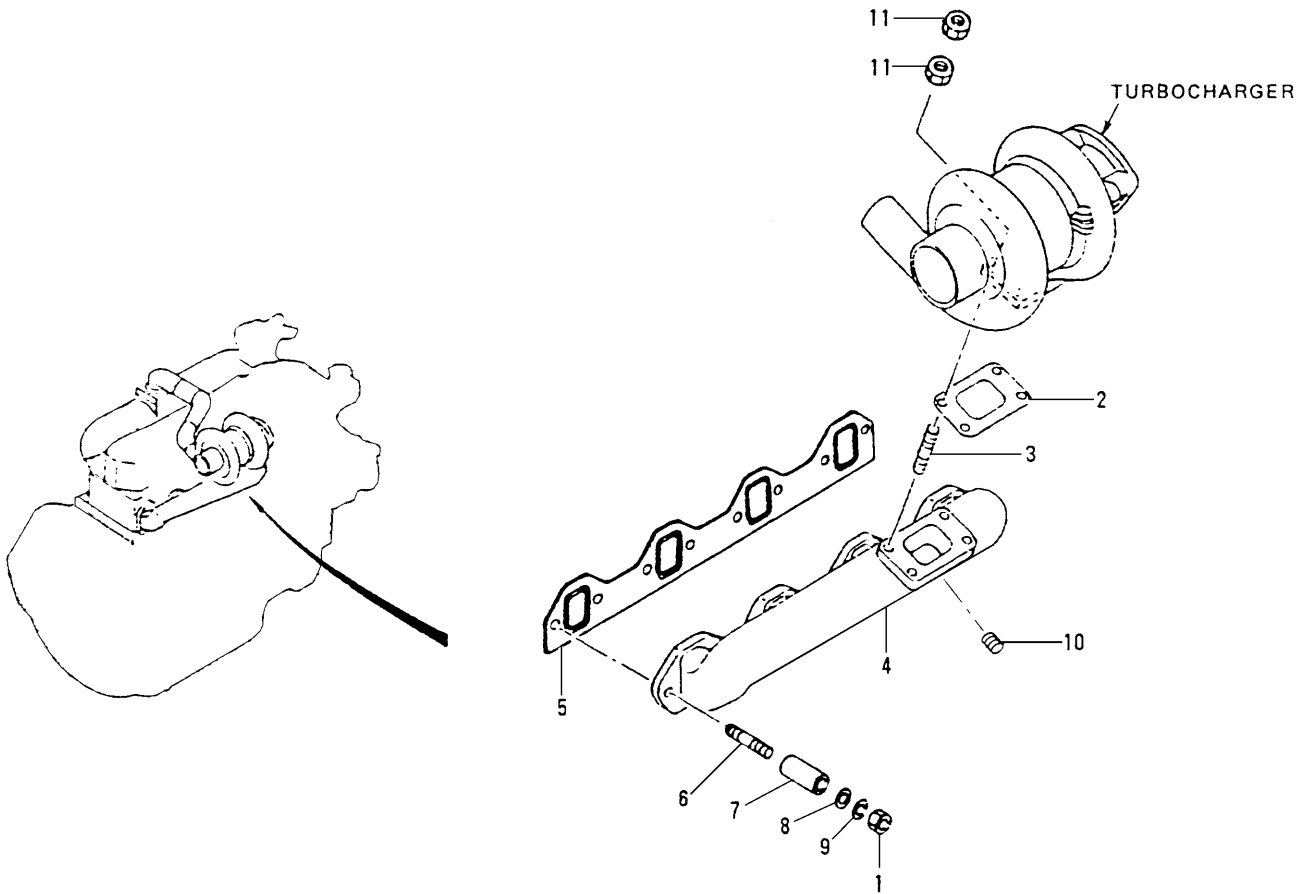

NOTE	No.	PART No.	QTY	PART NAME	NOTE	No.	PART No.	QTY	PART NAME
	1	5C-7261	8	NUT					
	2	51-7933	1	GASKET					
	3	178-6554	4	STUD					
	4	196-8006	1	MANIFOLD					
	5	196-8007	1	GASKET					
	6	51-7549	8	STUD					
	7	51-7550	8	SPACER					
	8	51-8013	8	WASHER					
	9	095-8638	8	WASHER					
	10	51-5087	1	PLUG					
	11	51-7633	8	NUT					

H71767E 00

196-7986 MANIFOLD GP-EXHAUST
Part of 162-6328-Page13

MEMORANDA

FUEL SYSTEM

NOTE	No.	PART No.	QTY	PART NAME	NOTE	No.	PART No.	QTY	PART NAME
	1	8 T - 4 1 8 9	6	BOLT (L=20mm)					
	2	8 T - 4 2 2 4	14	WASHER					
	3	4 D - 6 4 6 6	2	CLIP					
	4	1 2 0 - 0 0 0 9	1	LEVER AS					
	5	7 X - 2 5 3 4	2	BOLT (L=50mm)					
	6	9 X - 8 2 5 6	2	WASHER					
	7	5 C - 7 2 6 1	2	NUT					
	8	8 T - 4 1 3 6	3	BOLT (L=25mm)					
	9	8 T - 4 1 2 1	3	WASHER					
	10	1 9 5 - 8 9 4 3	1	SUPPORT AS					
	11	1 7 7 - 7 6 3 6	1	COVER AS					
	12	1 7 1 - 2 5 9 0	1	MOTOR AS					
		1 0 2 - 8 8 0 6	1	RECEPTACLE KIT					
		8 T - 8 7 3 7	1	PLUG					
		9 X - 3 4 0 1	7	PIN					
		1 5 7 - 3 1 6 0	2	JOINT					
	13	7 X - 2 5 3 7	2	BOLT (L=35mm)					
	14	8 T - 4 2 0 0	2	BOLT (L=16mm)					
	15	1 9 5 - 8 8 3 4	1	BRACKET AS					

H77486E 03

164-8276 CONTROL GP-GOVERNOR

ELECTRICAL AND STARTING SYSTEM

NOTE	No.	PART No.	QTY	PART NAME	NOTE	No.	PART No.	QTY	PART NAME
Y	1	3S-2093	15	STRAP					
	2	183-1001	1	HARNES AS					
	3	8T-4185	1	BOLT (L=50mm)					
	4	8T-4137	8	BOLT (L=20mm)					
	5	8T-4121	11	WASHER					
	6	111-4836	10	CLIP					
	7	116-0118	3	CLIP					
	8	8T-4191	2	BOLT (L=16mm)					
	9	111-4837	1	CLIP					
	10	6G-2263	1	SPACER					
	11	7K-1181	1	STRAP					

Y-SEE SEPARATE ILLUSTRATION

H75118E 05

170-6816 BATTERY & WIRING GP (2/3)
 S/N CAE 00395-00859
 183-1001-Page88

ELECTRICAL AND STARTING SYSTEM

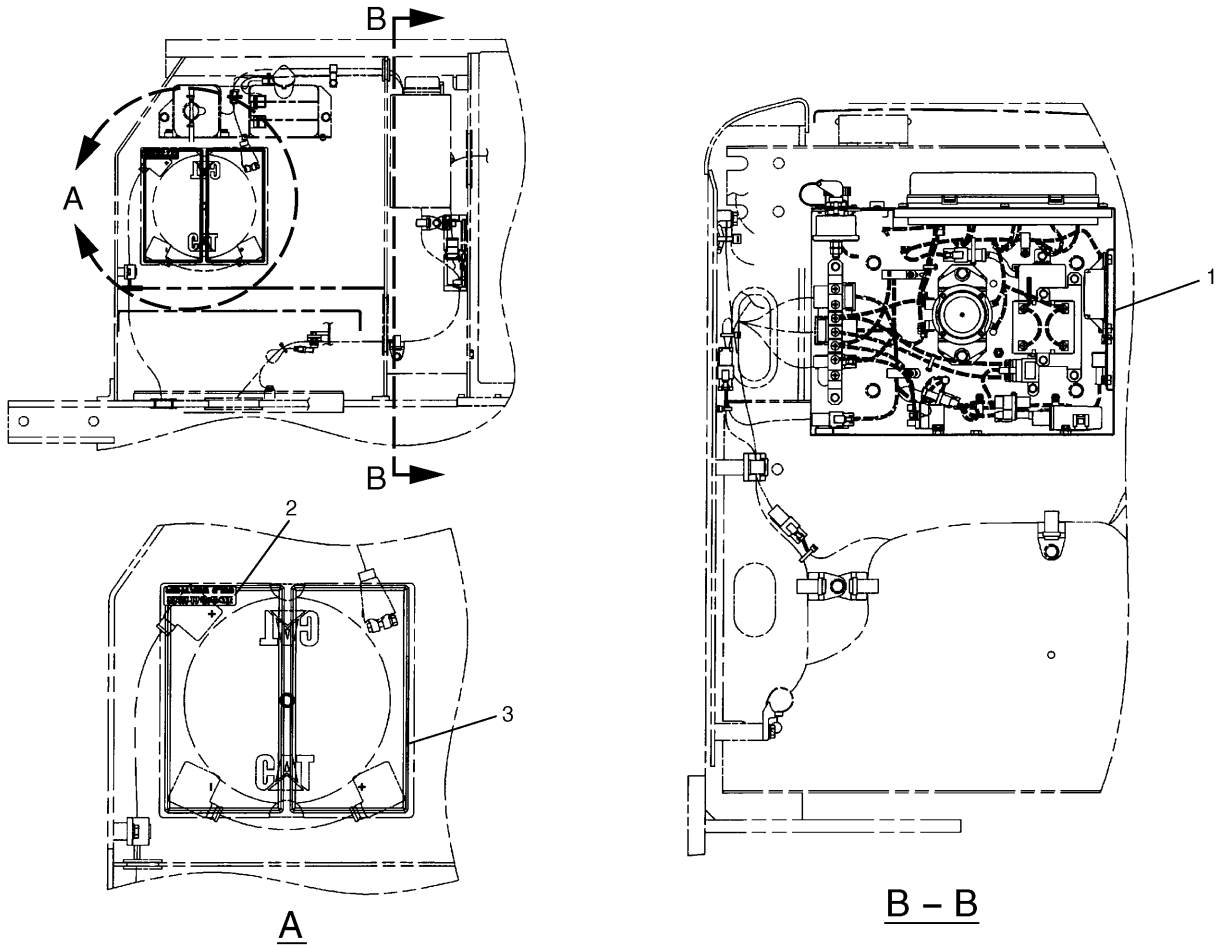

NOTE	No.	PART No.	QTY	PART NAME	NOTE	No.	PART No.	QTY	PART NAME
Y	1	193-3516	1	PANEL GP					
	2	102-5420	1	FILM (INSTRUCTION)					
	3	9X-3404	2	BATTERY					

Y-SEE SEPARATE ILLUSTRATION

H74737E 00

193-3533 BATTERY & WIRING GP-COLD WEATH

Part of 198-2321-Page78
193-3516-Page93.01
An Attachment

ELECTRICAL AND STARTING SYSTEM

NOTE	No.	PART No.	QTY	PART NAME	NOTE	No.	PART No.	QTY	PART NAME
	1	3T-4696	3	TERMINAL					
	2	9W-0844	28	SOCKET					
	3	9X-3402	26	SOCKET					
	4	9G-3695	37	PLUG					
	5	102-8802	5	RECEPTACLE KIT					
	6	155-2261	6	WEDGE					
	7	102-8804	2	RECEPTACLE KIT					
	8	186-3736	16	SOCKET					
	9	155-2258	4	WEDGE					
	10	8T-8729	15	PIN					
	11	9X-3401	17	PIN					
	12	9W-0852	17	PIN					
	13	3S-2093	13	STRAP					
	14	155-2263	1	WEDGE					
	15	102-7964	1	CONNECTOR					
	16	125-4841	1	WEDGE					
	17	102-7965	16	TERMINAL					
	18	163-6699	1	CONNECTOR					
	19	163-6790	9	TERMINAL					
	20	125-4785	16	TERMINAL					
	21	163-6659	1	CONNECTOR					
	22	155-2260	3	PLUG KIT					
	23	155-2270	6	PLUG KIT					
	24	155-2271	1	PLUG KIT					
	25	155-2255	4	PLUG KIT					
	26	102-8806	1	RECEPTACLE KIT					
	27	102-8801	4	RECEPTACLE KIT					
	28	102-8803	1	RECEPTACLE KIT					
	29	169-8672	1	PLUG AS					

H81737E 03

ELECTRICAL AND STARTING SYSTEM

NOTE	No.	PART No.	QTY	PART NAME	NOTE	No.	PART No.	QTY	PART NAME
Y	1	104-3204	1	CONTROLLER					
	2	125-1302	1	SWITCH AS (START RELAY)					
	3	163-6758	1	WIRE AS					
			102-8802	1	RECEPTACLE KIT				
			186-3735	2	PIN				
	4	170-9409	1	WIRE AS					
			2L-8050	2	TERMINAL				
	5	8T-4171	2	BOLT (L=12mm)					
	6	8T-6411	7	SCREW					
	7	9X-8256	24	WASHER					
	8	163-6757	1	WIRE AS					
			2L-8050	2	TERMINAL				
	9	111-4829	1	WIRE AS					
			2L-8050	2	TERMINAL				
	10	193-3520	1	BRACKET AS					
	11	121-1023	1	BLOCK					
	12	8C-7581	5	SCREW					
13	096-6166	5	WASHER						
14	3E-8048	4	SCREW						
15	096-5962	4	WASHER						
16	136-4055	1	STRIP						
17	193-3526	1	WIRE AS						
		2L-8050	1	TERMINAL					
		2L-8051	1	TERMINAL					
Y	18	163-6703	1	TIMER AS					
	19	105-9980	1	CLIP					
	20	7X-2619	11	BOLT (L=10mm)					
	21	193-3528	1	CABLE AS					
			9G-4343	2	TERMINAL				
	22	3S-2093	5	STRAP					
	23	105-9982	1	CLIP					
	24	111-4719	1	CLIP					
	25	167-3593	1	STRAP					
	26	105-9986	1	CLIP					
	Y	27	193-3524	1	HARNESS AS				
28		105-9983	1	CLIP					
29		5C-2890	2	NUT					
30		9X-8124	1	SWITCH AS (HEATER RELAY)					
			8T-4134	2	NUT				
31		193-3527	1	WIRE AS					
			2L-8050	1	TERMINAL				
			2L-8051	1	TERMINAL				
32		170-6935	1	WIRE AS					
			2L-8050	2	TERMINAL				
33		193-3525	1	WIRE AS					
			2L-8050	1	TERMINAL				
		2L-8051	1	TERMINAL					
34	193-3529	1	CABLE AS						
		9G-4343	2	TERMINAL					
35	165-4026	1	SWITCH AS (MAIN RELAY)						
36	4F-2294	2	NUT						
37	6V-8186	2	NUT						
38	6V-8378	2	NUT						

Y-SEE SEPARATE ILLUSTRATION

H75125E 01

193-3530 PANEL GP-CIRCUIT BREAKER (2/2)

Part of 170-6816-Page73

193-3524-Page94,125-1302-Page99,163-6703-Page102

ELECTRICAL AND STARTING SYSTEM

NOTE	No.	PART No.	QTY	PART NAME	NOTE	No.	PART No.	QTY	PART NAME
	1	183-1000	1	BASE AS					
		9X-8256	2	WASHER					
		095-0742	2	SCREW					
		170-9394	32	TERMINAL					
	2	149-5051	6	CONNECTOR					
	3	3S-2093	8	STRAP					
	4	7Y-3951	9	TERMINAL					
	5	121-1022	2	DIODE					
	6	7Y-3952	2	CONNECTOR					
	7	7Y-3963	3	TERMINAL					
	8	170-6890	2	TERMINAL					
	9	170-6891	14	TERMINAL					
	10	2L-8076	5	TERMINAL					
	11	7Y-3958	1	CONNECTOR					
	12	2L-8067	2	TERMINAL					
	13	149-5069	6	TERMINAL					
	14	149-5070	12	TERMINAL					
	15	149-5071	6	TERMINAL					
	16	7Y-3965	4	TUBE					

H82015E 02

193-3517 HARNESS AS (1/2)
 Part of 193-3516-Page93.04
 An Attachment

ELECTRICAL AND STARTING SYSTEM

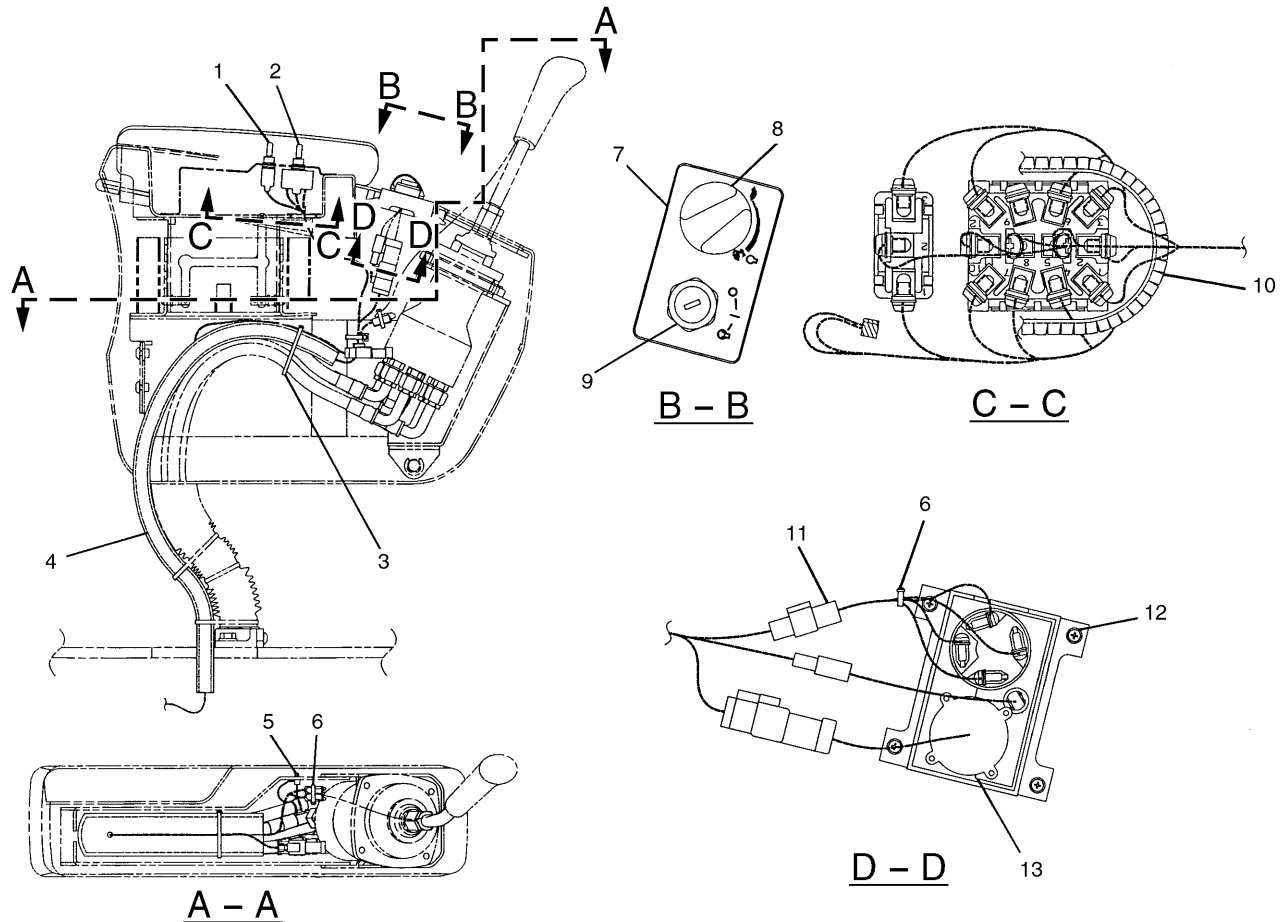

NOTE	No.	PART No.	QTY	PART NAME	NOTE	No.	PART No.	QTY	PART NAME
	1	163-6711	1	SWITCH AS (BACKUP)					
	2	163-6710	1	SWITCH AS (BACKUP)					
	3	7K-1181	1	STRAP					
Y	4	197-4276	1	HARNESS AS					
	5	163-6795	1	STRAP					
	6	3S-2093	2	STRAP					
	7	163-6702	1	PANEL AS					
		170-9324	1	BULB AS					
	8	185-9208	1	KNOB AS					
		185-9209	1	SPRING					
		124-4003	1	PLATE					
Y	9	9G-7641	1	SWITCH GP (ENGINE STARTER)					
D	10	6V-5738		TRIM... (0.13m)					
Y	11	170-6828	1	HARNESS AS					
	12	119-5026	4	SCREW					
Y	13	106-0107	1	SWITCH AS (ACCELERATOR)					

D—ORDER BY THE METER

Y—SEE SEPARATE ILLUSTRATION

H74278E 06

163-6626 WIRING GP-CONSOLE

Part of 163-6624-Page103

197-4276-Page109, 170-6828-Page112, 9G-7641-Page114, 106-0107-Page115

ELECTRICAL AND STARTING SYSTEM

	NOTE	No.	PART No.	QTY	PART NAME
		1	2L-8075	4	TERMINAL
		2	120-7724	1	CONNECTOR
		3	7Y-3950	4	TERMINAL
H67109E 01					

170-6829 HARNESS AS-CONSOLE
Part of 170-6828-Page112

	NOTE	No.	PART No.	QTY	PART NAME
		1	2L-8075	4	TERMINAL
		2	120-7724	1	CONNECTOR
		3	7Y-3950	4	TERMINAL
H67110E 01					

170-6830 HARNESS AS-CONSOLE
Part of 170-6828-Page112

ELECTRICAL AND STARTING SYSTEM

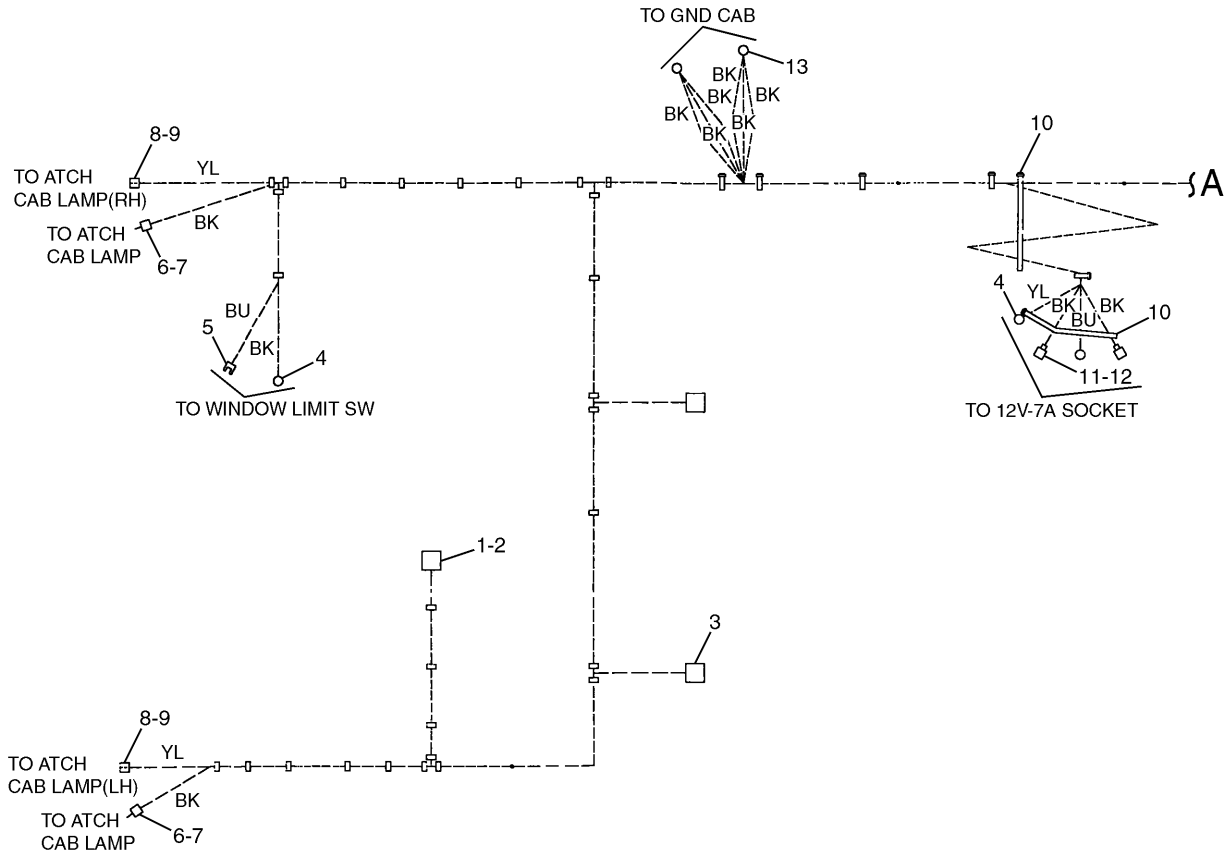

NOTE	No.	PART No.	QTY	PART NAME	NOTE	No.	PART No.	QTY	PART NAME
	1	167-3631	2	TERMINAL					
	2	167-3630	1	CONNECTOR					
	3	7Y-3950	4	TERMINAL					
	4	2L-8075	3	TERMINAL					
	5	5P-2321	1	TERMINAL					
	6	7Y-3962	2	TERMINAL					
	7	7Y-3964	2	TUBE					
	8	7Y-3963	2	TERMINAL					
	9	7Y-3965	2	TUBE					
	10	3S-2093	7	STRAP					
	11	153-2631	2	TERMINAL					
	12	153-2602	2	CONNECTOR					
	13	2L-8066	2	TERMINAL					

H84023E 06

ELECTRICAL AND STARTING SYSTEM

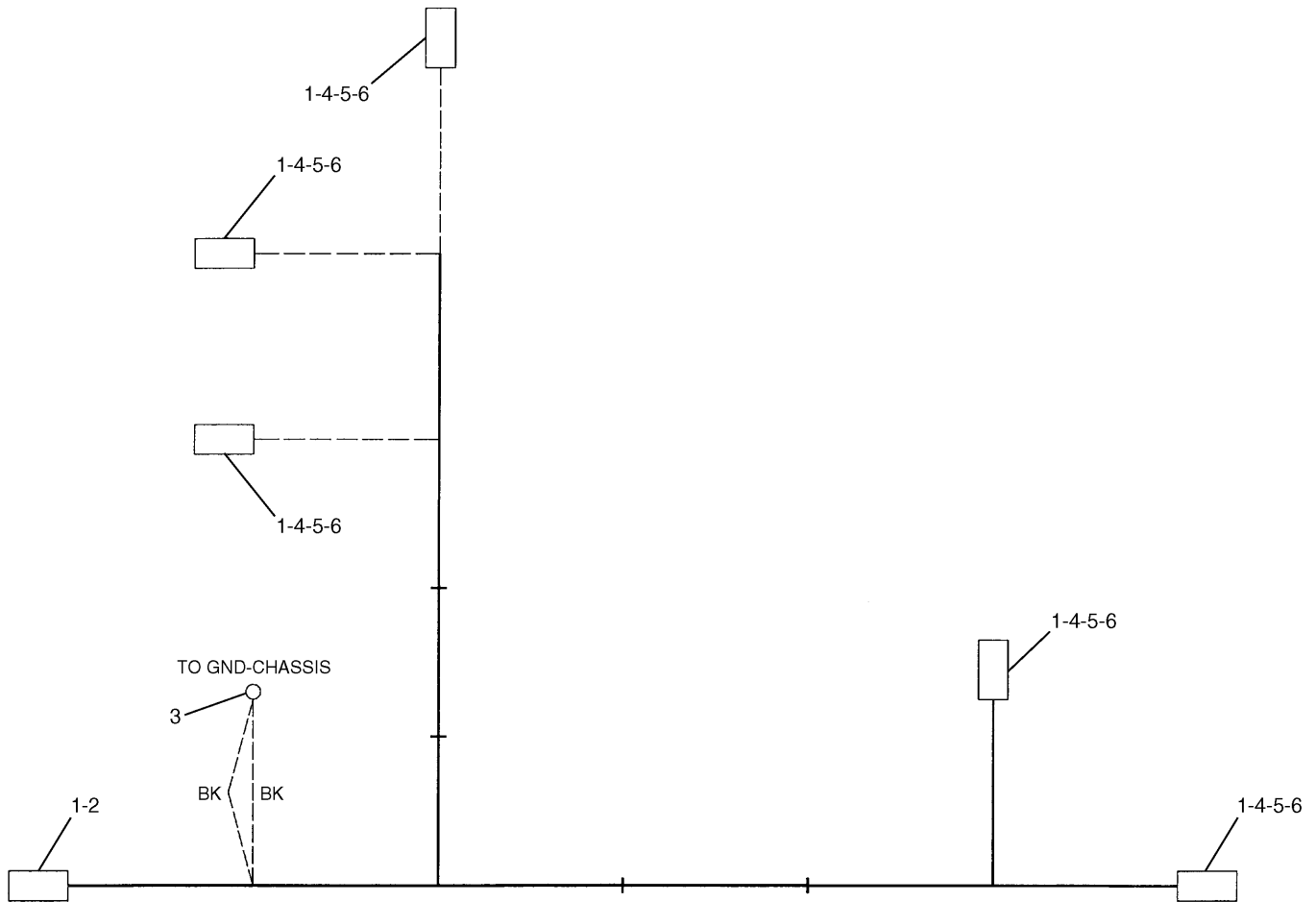

NOTE	No.	PART No.	QTY	PART NAME	NOTE	No.	PART No.	QTY	PART NAME
	1	106-9618	8	SOCKET					
	2	155-2260	1	PLUG KIT					
	3	3T-4696	1	TERMINAL					
	4	155-2270	5	PLUG KIT					
	5	155-2261	5	WEDGE					
	6	186-3736	5	SOCKET					

H71777E 01

170-6923 HARNESS AS-WIRING
Part of 170-6822-Page135
An Attachment

ELECTRICAL AND STARTING SYSTEM

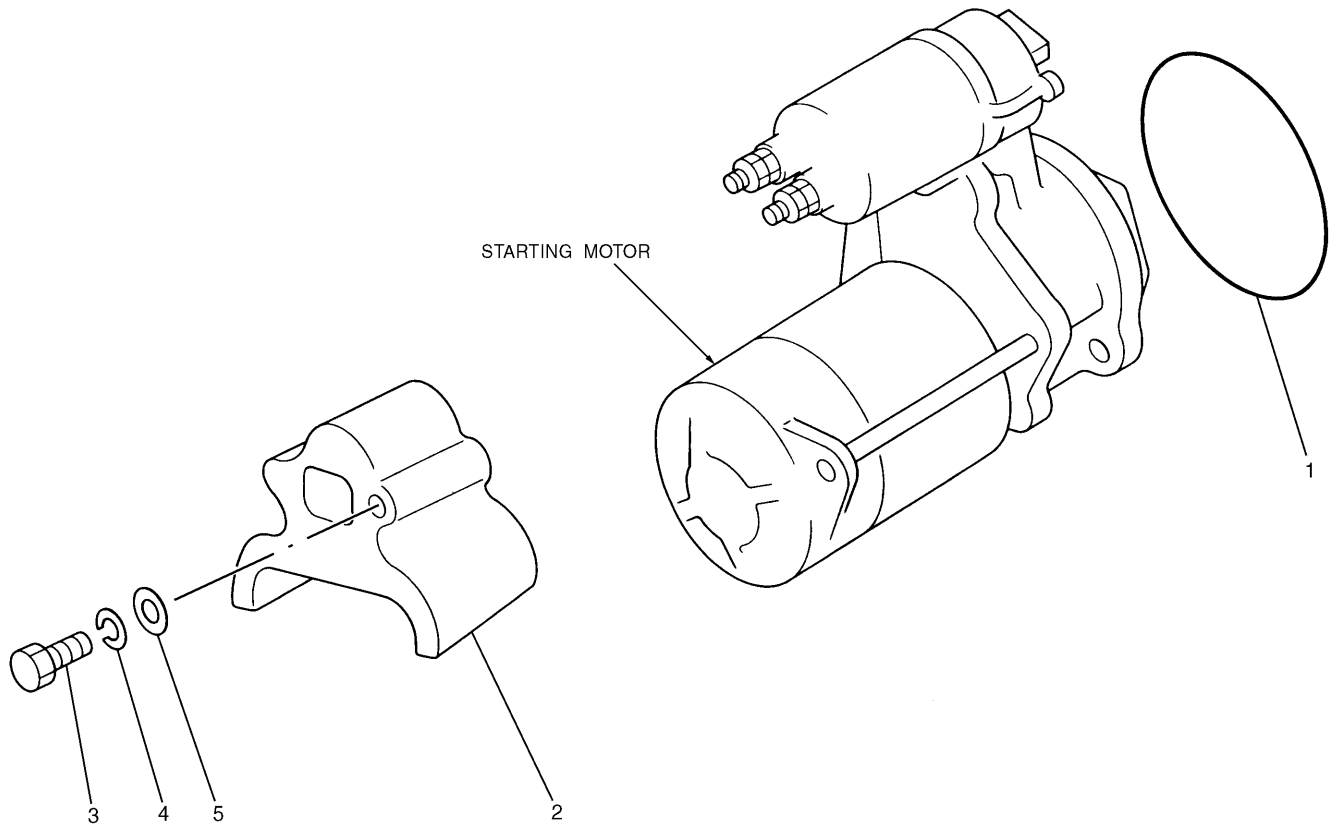

NOTE	No.	PART No.	QTY	PART NAME	NOTE	No.	PART No.	QTY	PART NAME
	1	51-7599	1	SEAL-O-RING (ID=79.50mm)					
	2	135-2369	1	COVER					
	3	135-2370	1	BOLT (L=25mm)					
	4	3B-4503	1	LOCKWASHER					
	5	8T-0328	1	WASHER					

H78542E 02

125-2963 MOUNTING GP-STARTING MOTOR
Part of 162-6328-Page13

ELECTRICAL AND STARTING SYSTEM

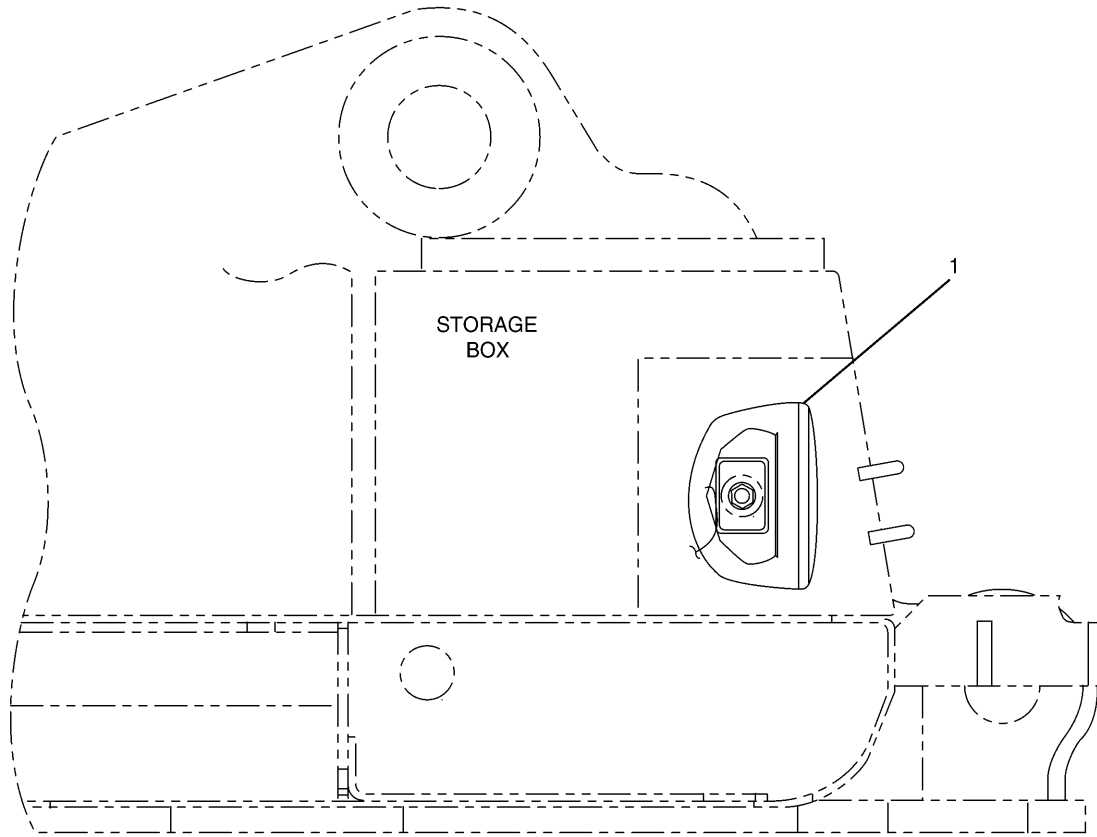

NOTE	No.	PART No.	QTY	PART NAME	NOTE	No.	PART No.	QTY	PART NAME
Y	1	153-2523	1	LAMP GP					

Y-SEE SEPARATE ILLUSTRATION

H62242E 03

4I-5409 LIGHTING GP-CHASSIS
153-2523-Page159

ELECTRICAL AND STARTING SYSTEM

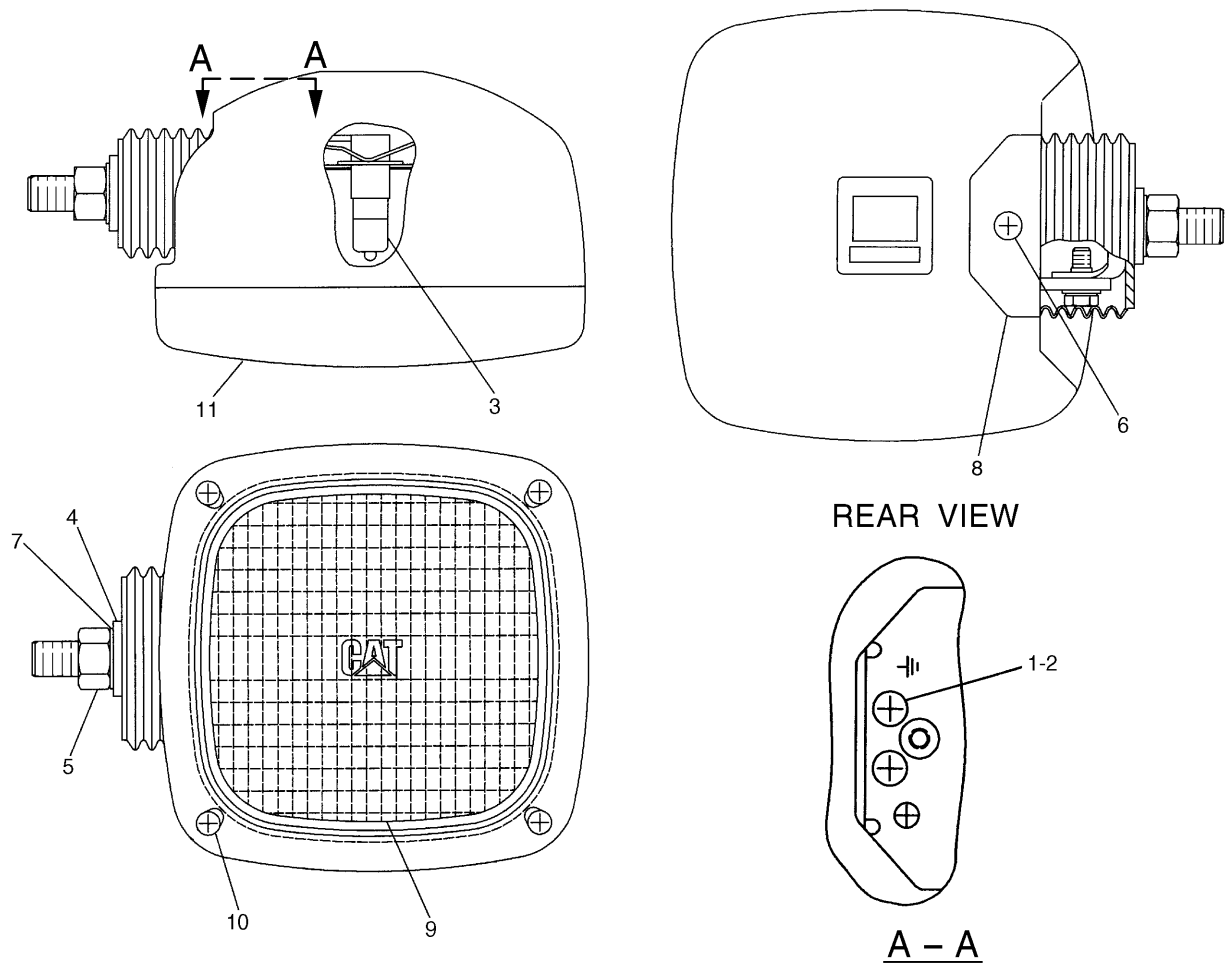

NOTE	No.	PART No.	QTY	PART NAME	NOTE	No.	PART No.	QTY	PART NAME
	1	6V-5210	2	SCREW					
	2	3B-4501	2	LOCKWASHER					
	3	9X-3463	1	BULB					
	4	8T-4223	1	WASHER					
	5	8T-4244	1	NUT					
	6	174-7791	1	SCREW					
	7	5C-2889	1	LOCKWASHER					
	8	170-6993	1	COVER					
	9	170-9417	1	LENS AS					
	10	180-3861	4	SCREW					
	11	170-9418	1	BAND					

H66567E 02

153-2523 LAMP GP-FLOOD
Part of 4I-5409-Page151

MEMORANDA

FRAME AND BODY

NOTE	No.	PART No.	QTY	PART NAME	NOTE	No.	PART No.	QTY	PART NAME
	1	8 T - 4 1 9 3	32	BOLT (L=50mm)					
	2	9 X - 8 2 5 7	46	WASHER					
	3	8 T - 7 3 3 8	14	BOLT (L=45mm)					
	4	5 D - 1 0 2 6	1	CLAMP					
	5	1 9 1 - 2 5 4 3	2	PIN					
B	6	1 U - 8 8 4 6		GASKET MAKER... (15ml)					
E	7	5 P - 0 7 6 7		HOSE... (62cm)					
	8	1 1 4 - 1 3 7 4	1	SUPPORT					
	9	8 T - 4 1 9 1	1	BOLT (L=16mm)					
	10	8 T - 4 1 2 1	1	WASHER					

B—USE AS REQUIRED
 E—ORDER BY THE CENTIMETER

H75143E 05

169-5545 FASTENER GP-SWING & FINAL DR

FRAME AND BODY

NOTE	No.	PART No.	QTY	PART NAME	NOTE	No.	PART No.	QTY	PART NAME
	1	8 T - 4 1 9 2	27	BOLT (L=25mm)					
	2	8 T - 4 1 3 9	17	BOLT (L=30mm)					
	3	5 P - 1 0 7 6	44	WASHER					
	4	8 T - 4 1 2 1	2	WASHER					
	5	8 T - 4 1 3 6	2	BOLT (L=25mm)					

H77541E 04

170-2600 HOOD & GUARD GP (5/5)

FRAME AND BODY

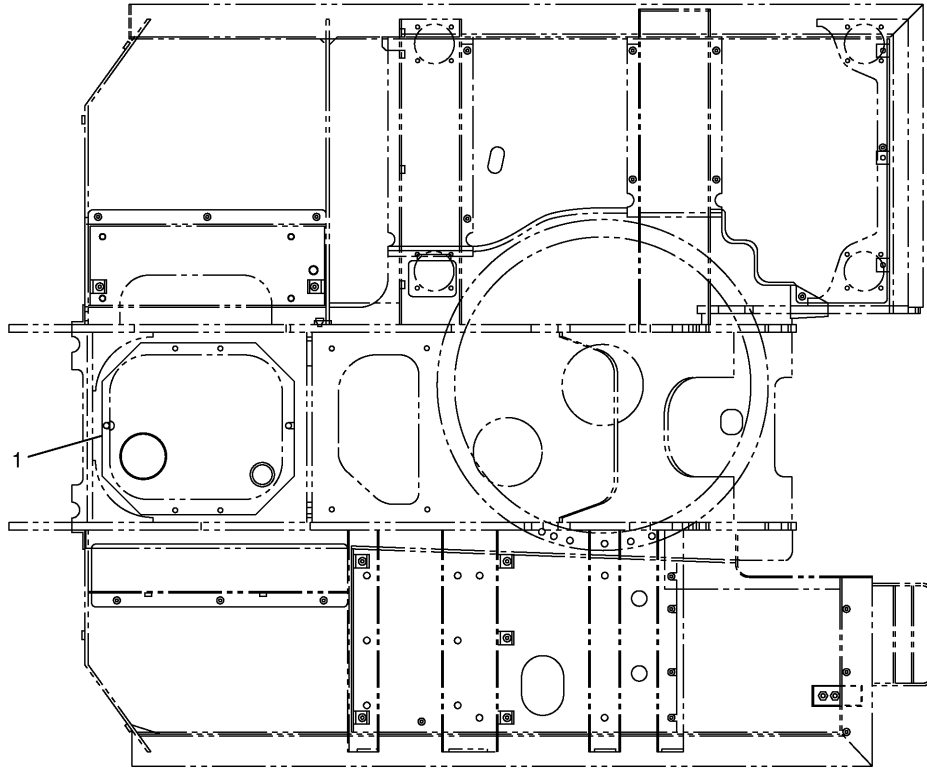

NOTE	No.	PART No.	QTY	PART NAME	NOTE	No.	PART No.	QTY	PART NAME
	1	184-8210	1	SHEET AS					

H71907E 01

184-8209 GUARD GP-BOTTOM
 Part of 151-1493-Page552,151-1494-Page553,183-1476-Page553.01
 An Attachment

FRAME AND BODY

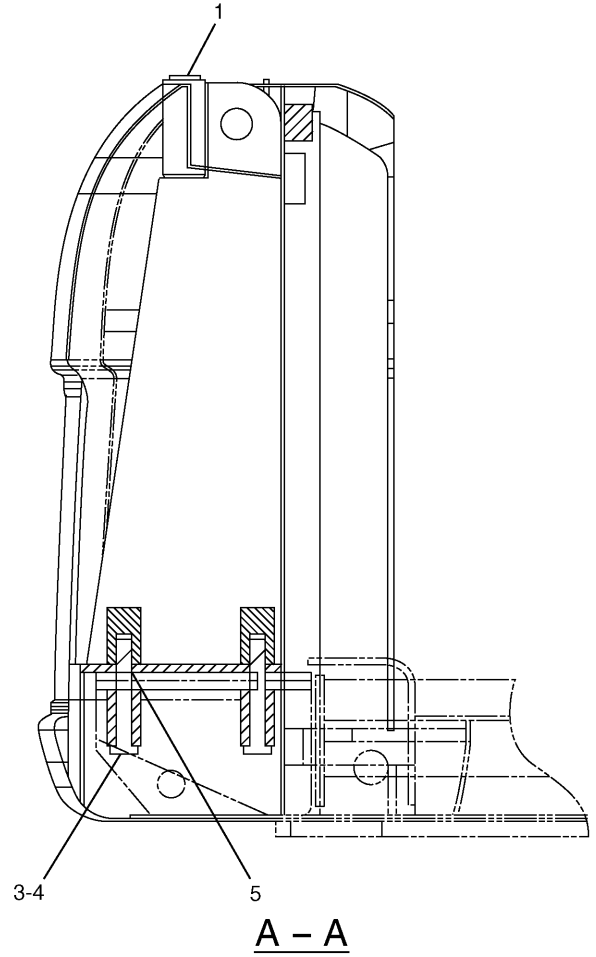
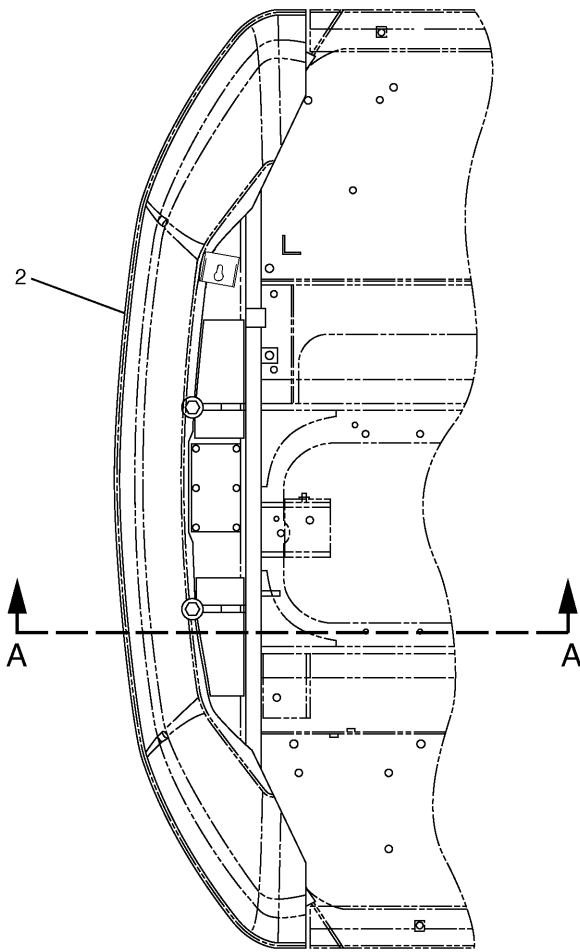

NOTE	No.	PART No.	QTY	PART NAME	NOTE	No.	PART No.	QTY	PART NAME
	1	41-0006	2	CAP					
Y	2	170-2597	1	COUNTERWEIGHT GP					
	3	177-5867	4	SPACER					
	4	8T-0671	4	BOLT (L=150mm)					
B	5	1R-7128	4	SHIM (T=1.00mm)					
B		71-0676	4	SHIM (T=1.60mm)					

B—USE AS REQUIRED
 Y—SEE SEPARATE ILLUSTRATION

H81915E 02

170-2595 COUNTERWEIGHT GP
 170-2597-Page208
 An Attachment

FRAME AND BODY

NOTE	No.	PART No.	QTY	PART NAME	NOTE	No.	PART No.	QTY	PART NAME
	1	121-5204	1	RETAINER					
	2	099-0913	1	CLAMP					
	3	121-5203	1	BOOT					
	4	8T-4136	12	BOLT (L=25mm)					
	5	8T-4121	12	WASHER					
	6	5K-9243	2	ELBOW					
	7	7X-2555	34	BOLT (L=80mm)					
	8	095-1299	1	DOWEL					
	9	8T-4199	2	BOLT (L=12mm)					
	10	4N-9170	2	CLIP					
	11	3B-8489	1	FITTING					
	12	4I-7446	1	GASKET					
	13	4I-7326	1	STRIP					
	14	169-5568	1	TUBE AS					
B	15	1U-8846		GASKET MAKER...(30ml)					
	16	8T-0357	38	BOLT (L=70mm)					
	17	085-9310	38	SPACER					
B	18	1U-8846		GASKET MAKER...(33ml)					
	19	191-2544	34	WASHER					
	20	171-9380	1	GEAR GP					
	21	3B-8489	1	FITTING					
E	22	148-4685		SEAL...(316cm)					
E	23	148-4685		SEAL...(318cm)					

B-USE AS REQUIRED

E-ORDER BY THE CENTIMETER

H75163E 00

199-4573 GEAR & BEARING GP-SWING
 Part of 151-1493-Page552,151-1494-Page553,183-1476-Page553.01
 An Attachment

FRAME AND BODY

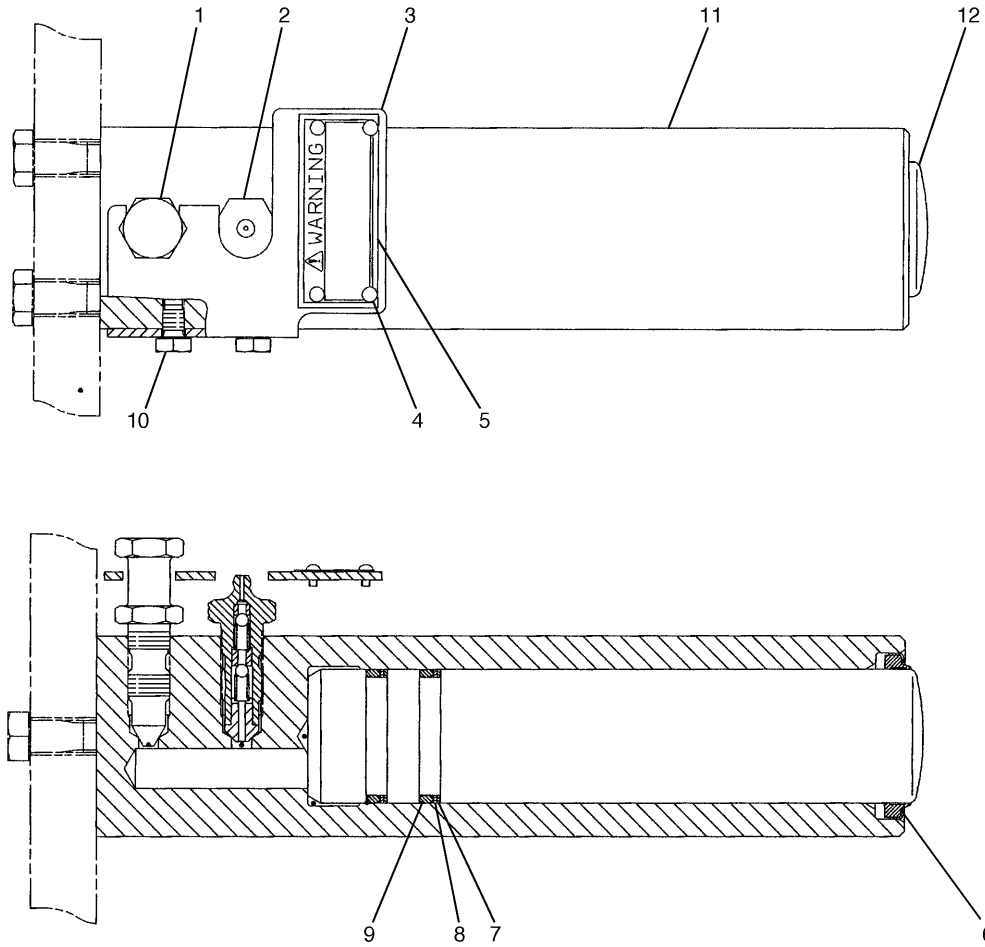

NOTE	No.	PART No.	QTY	PART NAME	NOTE	No.	PART No.	QTY	PART NAME
	1	2S-5926	1	VALVE (RELIEF)					
	2	095-2927	1	VALVE (FILL)					
	3	108-9122	1	PLATE AS					
	4	4B-4158	4	SCREW					
	5	5P-9891	1	PLATE (WARNING)					
	6	095-7101	1	SEAL					
	7	099-0172	2	RING					
	8	099-0173	2	RING					
	9	095-1607	2	SEAL-O-RING (ID=43.70mm)					
	10	8T-4199	2	BOLT (L=12mm)					
	11	168-6686	1	CYLINDER					
	12	168-6685	1	PISTON					

H71787E 01

168-6684 ADJUSTMENT GP-HYDRAULIC TRACK
Part of 168-6731-Page217

FRAME AND BODY

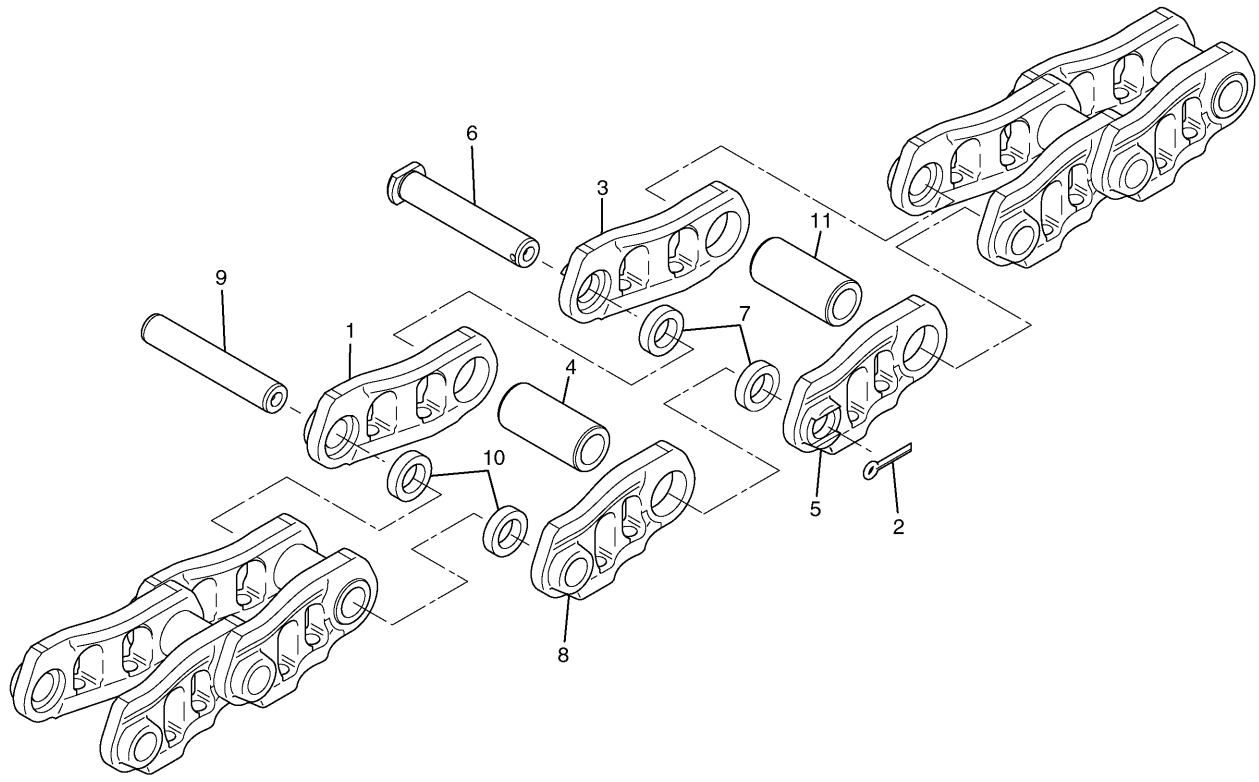

NOTE	No.	PART No.	QTY	PART NAME	NOTE	No.	PART No.	QTY	PART NAME
	1	41-7476	42	LINK					
	2	095-0863	1	COTTER					
	3	41-7478	1	LINK					
	4	162-4306	1	BUSHING					
	5	41-7477	1	LINK					
	6	099-0653	1	PIN					
	7	176-4872	2	SEAL					
	8	41-7475	42	LINK					
	9	162-4305	42	PIN					
	10	162-4307	84	SEAL					
	11	162-4304	42	BUSHING					

H71796E 01

176-4870 LINK AS-TRACK

Part of 176-4863,176-4864-Page228,176-4865-Page229,176-4869-Page230

HYDRAULIC SYSTEM

NOTE	No.	PART No.	QTY	PART NAME	NOTE	No.	PART No.	QTY	PART NAME
	1	179-7468	1	PIPE					
	2	8T-4136	6	BOLT (L=25mm)					
	3	8T-4121	14	WASHER					
	4	175-6177	1	FLANGE AS					
		175-6176	1	SEAL-O-RING (ID=56.00mm)					
		179-7472	1	FLANGE					
	5	2H-3934	1	SEAL-O-RING (ID=98.02mm)					
Y	6	188-4145	1	FILTER GP					
	7	8T-4137	6	BOLT (L=20mm)					
	8	8T-4908	4	BOLT (L=25mm)					
	9	8T-4224	4	WASHER					
Y	10	126-2075	1	FILTER GP					
	11	8T-4194	8	BOLT (L=50mm)					
	12	095-1725	1	SEAL-O-RING (ID=154.30mm)					
	13	4I-3745	1	CAP					
	14	1P-4278	1	CLAMP					
	15	105-2652	1	PLUG					
	16	6C-8496	1	WASHER					
	17	095-1608	1	SEAL-O-RING (ID=44.70mm)					
	18	1H-8278	1	SEAL-O-RING (ID=196.44mm)					
	19	8T-4223	8	WASHER					
	20	202-3792	1	SUPPORT					
	21	6V-0852	1	CAP					
	22	3J-1907	1	SEAL-O-RING (ID=11.89mm)					
	23	6V-3965	1	NIPPLE AS					
	24	8C-3446	1	VALVE					
	25	3J-7354	1	SEAL-O-RING (ID=8.92mm)					
	26	8C-3451	1	CAP					
	27	179-7536	1	COVER AS					
	28	4I-3743	1	FILLER AS					

Y-SEE SEPARATE ILLUSTRATION

H75175E 01

196-0927 TANK & FILTER GP-HYDRAULIC (2/2)

Part of 196-0926-Page233
126-2075-Page256,188-4145-Page260
An Attachment

HYDRAULIC SYSTEM

NOTE	No.	PART No.	QTY	PART NAME	NOTE	No.	PART No.	QTY	PART NAME
	1	095-7419	4	SCREW					
	2	176-0582	1	BLOCK					
	3	173-1203	1	PUMP GP					
	4	9S-4191	2	PLUG					
	5	3J-1907	2	SEAL-O-RING (ID=11.89mm)					
	6	8T-4139	8	BOLT (L=30mm)					
	7	8T-4137	2	BOLT (L=20mm)					
	8	7X-2553	6	BOLT (L=40mm)					
	9	218-0557	1	PUMP GP					
	10	7I-2272	2	BOLT (L=12mm)					
Y	11	111-9916	1	VALVE GP					
	12	094-1875	4	DOWEL					
Y	13	173-1168	2	HEAD GP					
	14	8T-4121	2	WASHER					
	15	8T-6466	2	BOLT (L=60mm)					
	16	094-1882	11	PLUG					
	17	8T-4140	1	BOLT (L=60mm)					
	18	199-0518	12	SEAL-O-RING (ID=6.80mm)					
	19	176-0581	1	CASE					
	20	8C-3338	2	DOWEL					

Y-SEE SEPARATE ILLUSTRATION

H81744E 11

183-8289 PUMP GP-MAIN HYDRAULIC (1/2)

Part of 183-8098-Page244
173-1168-Page254,111-9916-Page432
An Attachment

HYDRAULIC SYSTEM

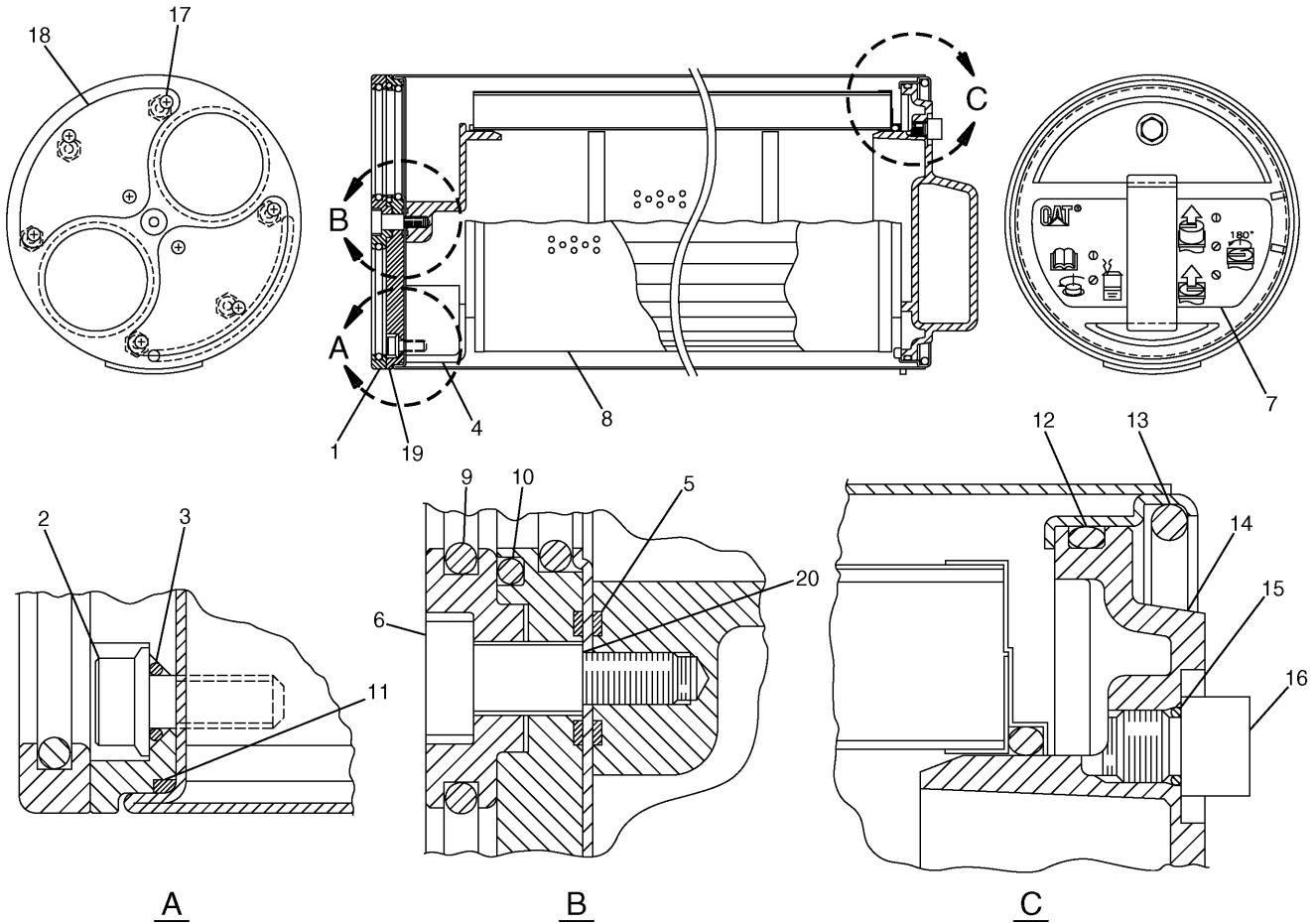

NOTE	No.	PART No.	QTY	PART NAME	NOTE	No.	PART No.	QTY	PART NAME
	1	173-3512	1	PLATE					
	2	173-3529	6	BOLT (L=15mm)					
	3	3T-7528	6	SEAL-O-RING (ID=5.80mm)					
	4	173-3513	1	BASE					
	5	3E-4297	2	SEAL-O-RING (ID=10.00mm)					
	6	137-3626	1	BOLT					
	7	188-4143	1	FILM (INSTRUCTION)					
	8	179-9806	1	ELEMENT					
	9	137-3623	4	SEAL-O-RING (ID=55.60mm)					
	10	6V-7658	2	SEAL-O-RING (ID=59.40mm)					
	11	177-2553	1	SEAL-O-RING (ID=149.50mm)					
	12	095-1681	1	SEAL-O-RING (ID=144.40mm)					
	13	173-3515	1	RING					
	14	173-3516	1	HANDLE					
	15	4J-7533	1	SEAL-O-RING (ID=6.07mm)					
	16	9S-4180	1	PLUG					
	17	137-3624	8	SCREW					
	18	137-3625	2	PAD					
	19	173-3517	1	PLATE					
	20	137-3628	1	SHIM (T=0.10mm)					

H69246E 00

188-4142 FILTER GP-HYDRAULIC
Part of 188-4145-Page260
An Attachment

HYDRAULIC SYSTEM

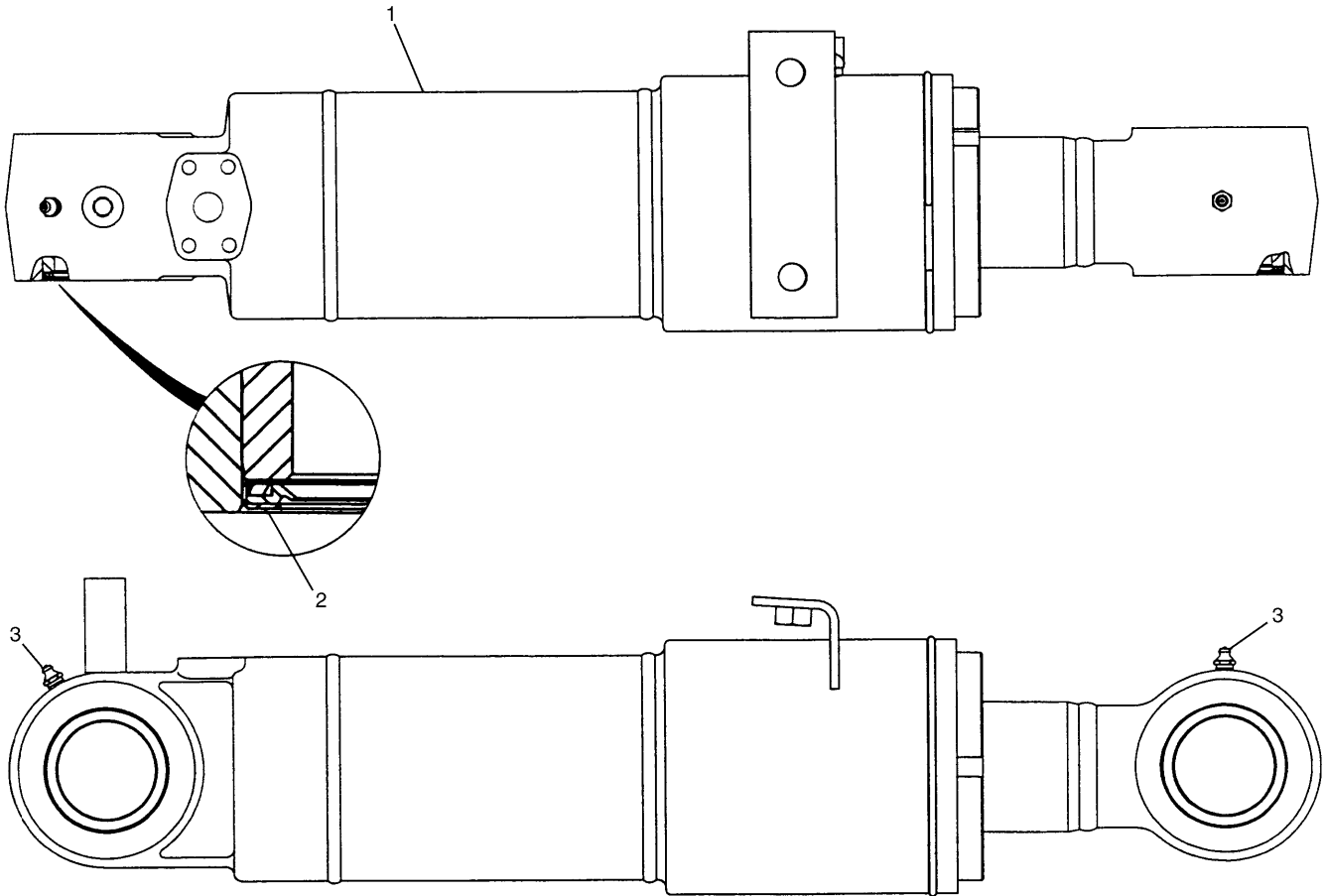

NOTE	No.	PART No.	QTY	PART NAME	NOTE	No.	PART No.	QTY	PART NAME
Y	1	170-9809	1	CYLINDER GP					
	2	093-1433	4	SEAL					
	3	3B-8489	2	FITTING					

Y-SEE SEPARATE ILLUSTRATION

H71496E 01

170-9804 CYLINDER & SEAL GP-BLADE
 Part of 165-9425-Page267
 170-9809-Page276
 An Attachment

HYDRAULIC SYSTEM

NOTE	No.	PART No.	QTY	PART NAME	NOTE	No.	PART No.	QTY	PART NAME
	1	139-1762	2	HOSE AS		54	187-6912	1	PLATE
	2	139-1765	2	HOSE AS		55	8T-4196	2	BOLT (L=35mm)
	3	179-7874	1	TUBE AS		56	8T-4121	2	WASHER
	4	179-7875	1	TUBE AS		57	8T-4184	1	BOLT (L=45mm)
	5	134-6838	1	GUARD		58	8T-0077	2	CONNECTOR
	6	187-6907	1	HOSE AS		59	6V-9851	1	ELBOW
	7	187-6904	1	HOSE AS					
	8	7K-1181	7	STRAP					
	9	199-1657	1	HOSE AS					
	10	8T-2530	2	ELBOW					
	11	187-7002	1	HOSE AS					
	12	187-7005	1	HOSE AS					
Y	13	185-0506	1	VALVE GP					
	14	6V-8640	1	CONNECTOR					
	15	6V-8642	1	CONNECTOR					
	16	6V-8713	2	CONNECTOR					
	17	6V-3965	1	NIPPLE AS					
	18	199-2046	1	GUARD					
	19	6V-9833	1	CAP AS					
	20	6V-0852	1	CAP					
	21	6V-8722	2	ELBOW					
	22	7J-9108	13	SEAL-O-RING (OD=19.28mm)					
	23	5A-3604	3	BOLT (L=25mm)					
	24	6V-9008	2	ELBOW					
	25	093-1295	3	CLAMP					
	26	8T-4194	2	BOLT (L=50mm)					
	27	8T-4223	4	WASHER					
	28	8T-4224	3	WASHER					
	29	5P-7464	1	CLIP					
	30	5P-7465	1	CLIP					
	31	8T-2920	1	GROMMET					
	32	8T-4139	1	BOLT (L=30mm)					
	33	6V-8778	1	TEE					
	34	8T-0120	1	ELBOW					
	35	3K-0360	6	SEAL-O-RING (ID=16.36mm)					
	36	3D-2824	3	SEAL-O-RING (ID=23.47mm)					
	37	2M-9780	2	SEAL-O-RING (ID=19.18mm)					
	38	6V-9746	2	SEAL-O-RING (OD=22.50mm)					
	39	5K-9090	5	SEAL-O-RING (OD=27.22mm)					
	40	7M-8485	3	SEAL-O-RING (ID=29.74mm)					
Y	41	162-4695	1	SWIVEL GP					
	42	131-9907	1	HOSE AS					
	43	179-7582	2	HOSE AS					
	44	199-1820	1	HOSE AS					
	45	3J-1907	1	SEAL-O-RING (ID=11.89mm)					
	46	7X-0872	1	TEE					
	47	6V-9854	1	ELBOW					
	48	6V-8946	1	REDUCER AS					
	49	196-0737	1	HOSE AS					
	50	196-0733	1	HOSE AS					
	51	187-6900	2	HOSE AS					
	52	194-0391	2	TUBE AS					
	53	6V-8398	7	SEAL-O-RING (OD=16.03mm)					

Y-SEE SEPARATE ILLUSTRATION

H77565E 03

196-0475 LINES GP-BLADE CYL & VALVE

Part of 198-2120,198-2121-Page551.03
162-4695-Page380.01,185-0506-Page429.04
An Attachment

HYDRAULIC SYSTEM

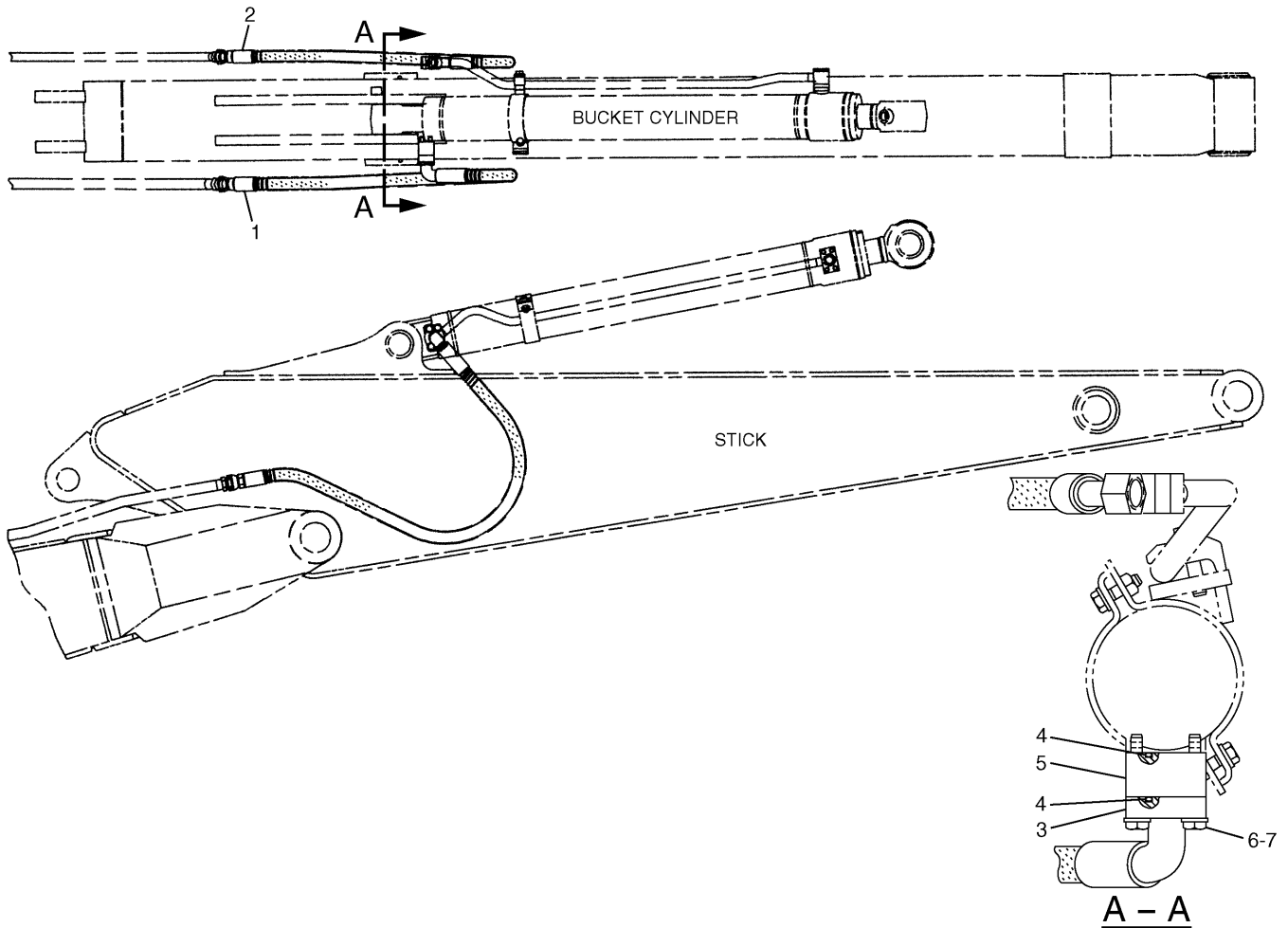

NOTE	No.	PART No.	QTY	PART NAME	NOTE	No.	PART No.	QTY	PART NAME
	1	104-8999	1	HOSE AS					
	2	124-0838	1	HOSE AS					
	3	1P-4576	2	FLANGE					
	4	4J-5267	2	SEAL-O-RING (ID=24.99mm)					
	5	131-9850	1	BLOCK					
	6	8T-5005	4	BOLT (L=70mm)					
	7	8T-4121	4	WASHER					

H71527E 01

179-7601 LINES GP-STICK
 Part of 151-1489-Page551,194-8988-Page551.01
 An Attachment

HYDRAULIC SYSTEM

NOTE	No.	PART No.	QTY	PART NAME	NOTE	No.	PART No.	QTY	PART NAME
	1	132-1567	1	TUBE AS					
	2	132-1568	1	TUBE AS					
	3	146-1321	1	HOSE AS					
E		5P-0201		HOSE...(132cm)					
		5P-1010	2	SLEEVE					
E		6V-0746		GUARD...(179cm)					
		7X-1452	2	STEM AS (STRAIGHT)					
	4	146-1325	1	HOSE AS					
E		5P-0200		HOSE...(133cm)					
		5P-1027	2	SLEEVE					
E		6V-0756		GUARD...(119cm)					
		7X-1451	2	STEM AS (STRAIGHT)					
Y	5	146-1464	2	VALVE AS					
	6	093-1292	2	CLAMP					
	7	093-1293	2	CLAMP					
	8	8T-4196	4	BOLT (L=35mm)					
	9	8T-0342	4	BOLT (L=80mm)					
	10	8T-4648	2	BOLT (L=70mm)					
	11	8T-4910	2	BOLT (L=60mm)					
	12	8T-4956	4	BOLT (L=35mm)					
	13	095-9397	4	LOCKWASHER					
	14	8T-4223	4	WASHER					
	15	1P-3703	2	SEAL					
	16	199-1905	1	SEAL-O-RING (ID=23.66mm)					
	17	199-1904	1	SEAL-O-RING (ID=18.94mm)					
	18	9S-4181	2	PLUG					
	19	7M-8485	2	SEAL-O-RING (ID=29.74mm)					

E—ORDER BY THE CENTIMETER
Y—SEE SEPARATE ILLUSTRATION

H82833E 05

127-6705 LINES GP-AUXILIARY HYDRAULIC
High Pressure Lines/R2.5 Stick
Part of 179-5077-Page293
146-1464-Page448.01
An Attachment

HYDRAULIC SYSTEM

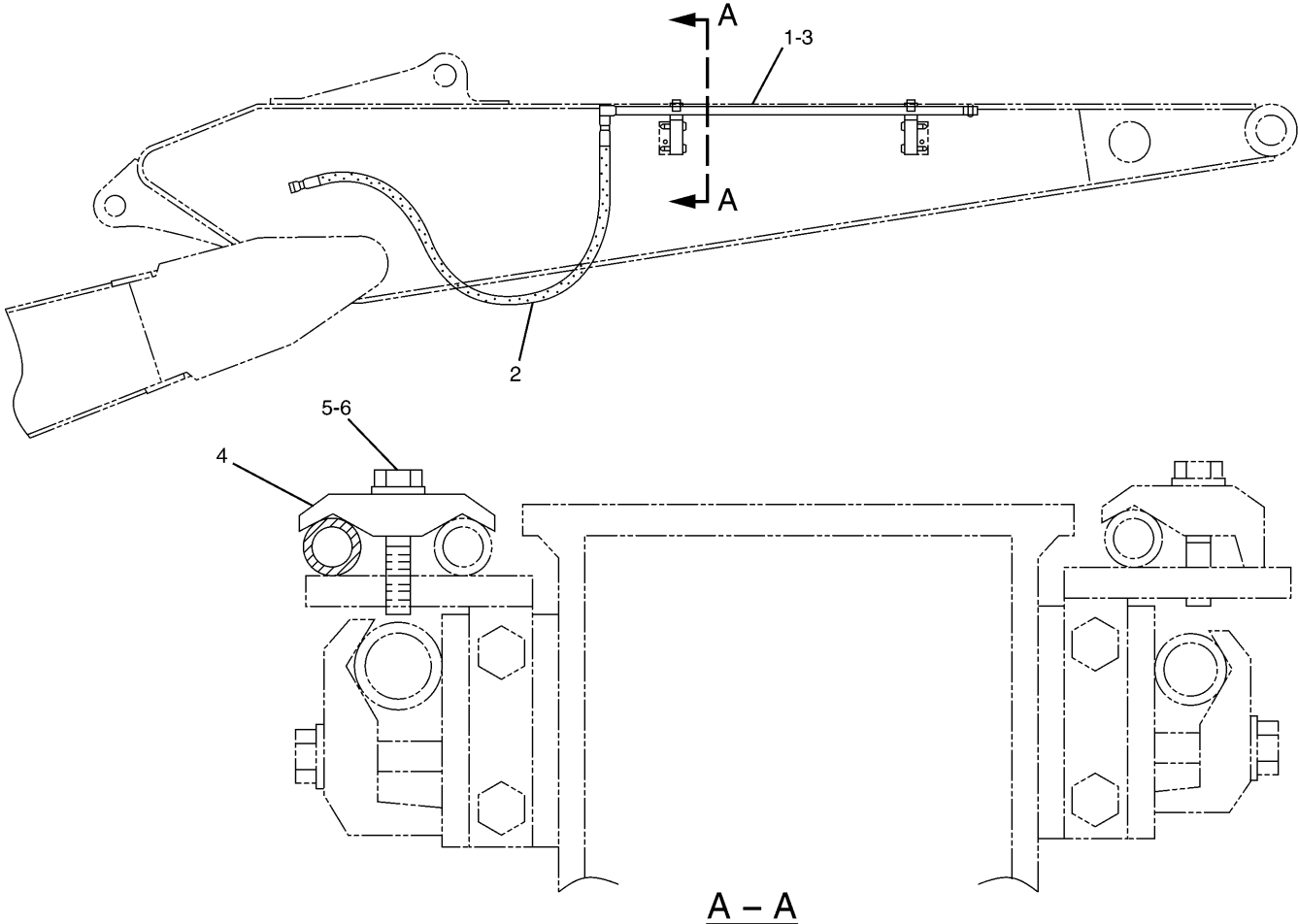

A - A

NOTE	No.	PART No.	QTY	PART NAME	NOTE	No.	PART No.	QTY	PART NAME
	1	173-7898	1	TUBE AS					
	2	173-7910	1	HOSE AS					
	3	6V-8398	2	SEAL-O-RING (OD=16.03mm)					
	4	096-5766	2	CLAMP					
	5	8T-4185	2	BOLT (L=50mm)					
	6	8T-4121	2	WASHER					

H71546E 01

179-5082 LINES GP-DRAIN
An Attachment

HYDRAULIC SYSTEM

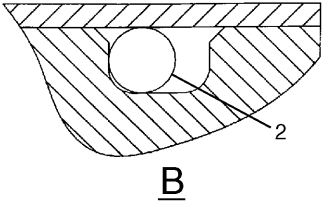
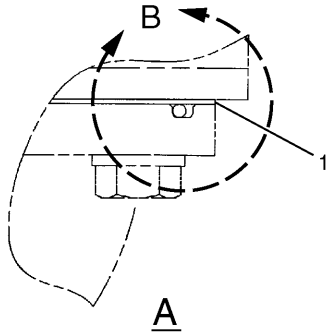
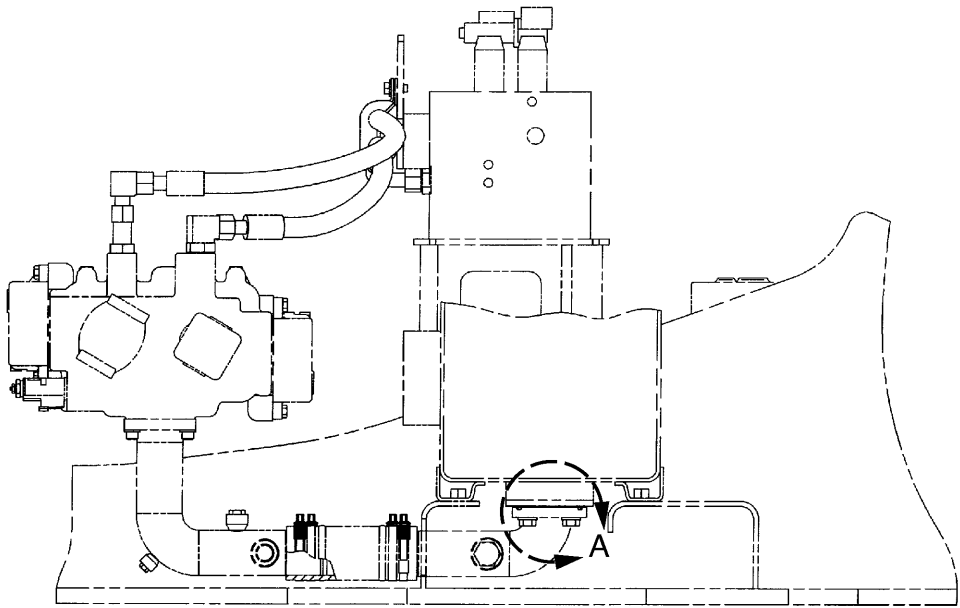

NOTE	No.	PART No.	QTY	PART NAME	NOTE	No.	PART No.	QTY	PART NAME
	1	207-6660	1	GASKET					
	2	5H-8624	1	SEAL-O-RING (ID=94.62mm)					

H79233E 00

207-6681 LINES GP-PUMP
S/N CAE 00636-00738

HYDRAULIC SYSTEM

NOTE	No.	PART No.	QTY	PART NAME	NOTE	No.	PART No.	QTY	PART NAME
	1	107-6631	3	CONNECTOR		52	170-9335	2	SWITCH AS (PRESSURE)
	2	6V-8636	26	CONNECTOR			126-1768	2	SOCKET
	3	6V-9001	4	ELBOW			155-2270	1	PLUG KIT
	4	6V-8724	10	ELBOW			155-2261	1	WEDGE
	5	8T-1905	3	ELBOW		53	41-3941	2	FITTING AS
	6	6V-8397	62	SEAL-O-RING (OD=12.83mm)		54	168-9759	1	BLOCK
	7	6V-8781	6	TEE		55	185-0383	1	BRACKET
	8	9S-4191	6	PLUG		56	184-9336	3	SUPPORT
Y	9	206-3303	1	VALVE GP (WORKING CONTROL)		57	104-8771	1	HOSE AS (NOM 06, L=2430mm)
Y	10	206-3304	1	VALVE GP (WORKING CONTROL)		58	104-8783	1	HOSE AS (NOM 06, L=2150mm)
Y	11	165-9522	1	VALVE GP (TRAVEL CONTROL)		59	3J-1907	62	SEAL-O-RING (ID=11.89mm)
	12	196-0715	1	BLOCK		60	8T-0075	4	CONNECTOR
	13	6V-7357	6	BOLT (L=25mm)		61	41-0800	1	HOSE AS (NOM 06, L=1300mm)
	14	8T-4136	4	BOLT (L=25mm)					
	15	8T-4137	13	BOLT (L=20mm)					
	16	8T-4198	2	BOLT (L=100mm)					
	17	9X-8256	6	WASHER					
	18	8T-4121	17	WASHER					
	19	184-9283	1	HOSE AS (NOM 06, L=1250mm)					
	20	184-9284	1	HOSE AS (NOM 06, L=1130mm)					
	21	184-9285	2	HOSE AS (NOM 06, L=1230mm)					
	22	184-9286	1	HOSE AS (NOM 06, L=1270mm)					
	23	176-4556	1	HOSE AS (NOM 06, L=1100mm)					
	24	176-4557	1	HOSE AS (NOM 06, L=1170mm)					
	25	176-4558	2	HOSE AS (NOM 06, L=1230mm)					
	26	176-4559	1	HOSE AS (NOM 06, L=1300mm)					
	27	176-4561	2	HOSE AS (NOM 06, L=1170mm)					
	28	104-8768	1	HOSE AS (NOM 06, L=2700mm)					
	29	41-0769	1	HOSE AS (NOM 06, L=2850mm)					
	30	7Y-4193	1	HOSE AS (NOM 06, L=2500mm)					
	31	71-8252	1	HOSE AS (NOM 06, L=2350mm)					
	32	41-3988	1	HOSE AS (NOM 06, L=2250mm)					
	33	41-3991	1	HOSE AS (NOM 06, L=2100mm)					
	34	7Y-4199	3	HOSE AS (NOM 06, L=1800mm)					
	35	110-5499	1	HOSE AS (NOM 06, L=1570mm)					
	36	087-4402	2	HOSE AS (NOM 06, L=480mm)					
	37	41-9521	8	BAND (L1,RED)					
	38	41-9522	8	BAND (L2,YELLOW)					
	39	41-9523	4	BAND (L3,BLUE)					
	40	41-9524	4	BAND (L4,BROWN)					
	41	41-9525	8	BAND (R1,ORANGE)					
	42	41-9526	8	BAND (R2,WHITE)					
	43	41-9527	4	BAND (R3,GREEN)					
	44	41-9528	4	BAND (R4,PURPLE)					
	45	133-5813	4	BAND (PGRAY)					
	46	115-8645	5	GUARD					
	47	7K-1181	19	STRAP					
	48	41-3953	2	GROMMET					
	49	51-4365	1	GROMMET					
	50	51-4366	1	GROMMET					
	51	087-4476	1	GROMMET					

Y-SEE SEPARATE ILLUSTRATION

H81749E 04

CLICK HERE TO **DOWNLOAD** THE COMPLETE MANUAL

- Thank you very much for reading the preview of the manual.
- You can download the complete manual from: www.heydownloads.com by clicking the link below



- Please note: If there is no response to CLICKING the link, please download this PDF first and then click on it.

CLICK HERE TO **DOWNLOAD** THE COMPLETE MANUAL

HYDRAULIC SYSTEM

NOTE	No.	PART No.	QTY	PART NAME	NOTE	No.	PART No.	QTY	PART NAME
	1	8 T-1905	1	ELBOW					
	2	6 V-8724	1	ELBOW					
	3	6 V-8636	3	CONNECTOR					
	4	107-6631	1	CONNECTOR					
	5	6 V-8781	1	TEE					
	6	9 S-4191	1	PLUG					
	7	087-5773	1	HOSE AS (NOM 06, L=1050mm)					
	8	087-4531	1	HOSE AS (NOM 06, L=600mm)					
	9	087-4402	2	HOSE AS (NOM 06, L=480mm)					
	10	4 I-0812	1	HOSE AS (NOM 06, L=2650mm)					
	11	179-7580	1	HOSE AS (NOM 06, L=360mm)					
	12	6 V-8774	1	TEE					
	13	167-3466	2	SWITCH AS (PRESSURE)					
		102-8802	1	RECEPTACLE KIT					
		9 X-3401	2	PIN					
	14	108-7516	1	FITTING					
	15	7 K-1181	5	STRAP					
	16	3 J-1907	10	SEAL-O-RING (ID=11.89mm)					
	17	6 V-8397	10	SEAL-O-RING (OD=12.83mm)					
	18	4 I-9527	4	BAND (R3, GREEN)					
Y	19	185-0462	1	VALVE GP					
	20	8 T-4137	3	BOLT (L=20mm)					
	21	8 T-4121	3	WASHER					

Y-SEE SEPARATE ILLUSTRATION

H77583E 02

168-9542 LINES GP-PILOT
 Part of 165-0963-Page317
 185-0462-Page446
 An Attachment

HYDRAULIC SYSTEM

NOTE	No.	PART No.	QTY	PART NAME	NOTE	No.	PART No.	QTY	PART NAME
E	1	199-1689	3	HOSE AS					
		7Y-5074		GUARD... (95cm)					
	2	123-2636	2	HOSE AS					
E	3	179-7464	1	HOSE AS					
		7Y-5074		GUARD... (90cm)					
	4	187-7173	2	HOSE AS					
	5	168-9754	1	TUBE AS					
	6	168-9755	1	TUBE AS					
	7	6V-8637	1	CONNECTOR					
	8	6V-8716	2	CONNECTOR					
	9	6V-8713	2	CONNECTOR					
	10	8T-4648	1	BOLT (L=70mm)					
	11	8T-4223	5	WASHER					
	12	096-4884	1	NUT					
	13	7I-7353	1	PLATE					
	14	8T-4192	2	BOLT (L=25mm)					
	15	8T-4910	1	BOLT (L=60mm)					
	16	7J-9108	6	SEAL-O-RING (OD=19.28mm)					
	17	093-1296	1	CLAMP					
	18	099-5408	1	CLAMP					
	19	8T-0197	1	CONNECTOR					
	20	9F-2167	1	SCREW					
	21	9S-4181	2	PLUG					
	22	7M-8485	5	SEAL-O-RING (ID=29.74mm)					
	23	3D-2824	3	SEAL-O-RING (ID=23.47mm)					
	24	6V-9746	4	SEAL-O-RING (OD=22.50mm)					

E—ORDER BY THE CENTIMETER

H75217E 01

168-9534 LINES GP-FRONT

HYDRAULIC SYSTEM

NOTE	No.	PART No.	QTY	PART NAME	NOTE	No.	PART No.	QTY	PART NAME
	1	194-0383	1	HOSE AS					
	2	113-6803	1	HOSE AS					
	3	7M-8485	1	SEAL-O-RING (ID=29.74mm)					
	4	4J-0520	1	SEAL-O-RING (ID=32.92mm)					
	5	187-6913	1	FLANGE					
	6	8T-6466	4	BOLT (L=60mm)					
Y	7	201-9367	1	VALVE GP					
Y	8	177-2653	1	VALVE GP					
	9	179-7708	1	TUBE AS					
	10	6V-9853	1	ELBOW					
	11	5K-9090	2	SEAL-O-RING (OD=27.22mm)					
	12	8T-4121	2	WASHER					
	13	194-0381	1	BLOCK					
	14	184-9390	1	SUPPORT AS					
	15	8T-4192	2	BOLT (L=25mm)					
	16	8T-4223	10	WASHER					
	17	095-9804	8	BOLT (L=110mm)					
	18	1P-3703	3	SEAL					
	19	8T-0197	1	CONNECTOR					
	20	8T-4176	4	BOLT (L=90mm)					
	21	099-8232	1	SEAL-O-RING (ID=28.24mm)					
	22	6V-9839	1	TEE					
	23	6V-9746	4	SEAL-O-RING (OD=22.50mm)					
	24	7Y-4868	2	CLIP					
	25	8T-4195	2	BOLT (L=30mm)					

Y-SEE SEPARATE ILLUSTRATION

H81750E 01

168-9543 LINES GP-FRONT (1/2)
 Part of 179-5071-Page318,165-0976-Page319
 177-2653-Page426,201-9367-Page437
 An Attachment

HYDRAULIC SYSTEM

NOTE	No.	PART No.	QTY	PART NAME	NOTE	No.	PART No.	QTY	PART NAME
	1	8 T - 4 1 3 9	4	BOLT (L=30mm)					
	2	1 7 9 - 7 7 0 5	1	SUPPORT AS					
	3	1 7 9 - 7 7 0 6	1	SUPPORT AS					
	4	1 7 9 - 7 7 0 4	1	BLOCK					
	5	8 T - 4 2 2 3	12	WASHER					
	6	0 9 5 - 9 8 0 4	4	BOLT (L=110mm)					
	7	1 P - 3 7 0 3	2	SEAL					
	8	1 7 9 - 7 6 6 2	1	COVER					
	9	8 T - 0 1 9 8	1	CONNECTOR					
	10	9 S - 4 1 8 3	1	PLUG					
	11	8 T - 4 9 5 6	4	BOLT (L=35mm)					
	12	6 V - 9 0 0 7	2	ELBOW					
	13	8 T - 4 1 8 3	4	BOLT (L=40mm)					
	14	6 V - 8 7 1 6	2	CONNECTOR					
Y	15	1 9 7 - 0 2 2 3	2	VALVE GP					
	16	6 V - 9 7 4 6	4	SEAL-O-RING (OD=22.50mm)					
	17	7 M - 8 4 8 5	3	SEAL-O-RING (ID=29.74mm)					
	18	5 K - 9 0 9 0	1	SEAL-O-RING (OD=27.22mm)					
	19	3 D - 2 8 2 4	3	SEAL-O-RING (ID=23.47mm)					

Y-SEE SEPARATE ILLUSTRATION

H81766E 01

196-0460 LINES GP-FRONT (2/2)
 Part of 200-6637-Page319.01,165-0967-Page319.02
 197-0223-Page423
 An Attachment

HYDRAULIC SYSTEM

NOTE	No.	PART No.	QTY	PART NAME	NOTE	No.	PART No.	QTY	PART NAME
	1	087-4432	1	HOSE AS					
	2	4J-0522	7	SEAL-O-RING (ID=37.69mm)					
	3	8T-4137	2	BOLT (L=20mm)					
	4	7M-8485	2	SEAL-O-RING (ID=29.74mm)					
Y	5	171-0002	1	VALVE GP					
	6	8T-5005	4	BOLT (L=70mm)					
	7	8T-4183	4	BOLT (L=40mm)					
	8	194-0202	1	PIPE					
	9	4J-0527	3	SEAL-O-RING (ID=56.74mm)					
	10	7X-7729	10	WASHER					
	11	1P-4578	8	FLANGE					
	12	8T-4196	16	BOLT (L=35mm)					
	13	8T-4121	22	WASHER					
	14	194-0201	1	PIPE AS					
	15	115-8782	1	HOSE					
	16	8T-6703	2	CLAMP					
	17	8T-4195	8	BOLT (L=30mm)					
	18	9S-4181	2	PLUG					
	19	173-4739	1	HOSE AS					
	20	196-0920	1	PIPE AS					
	21	179-7624	1	SUPPORT					
	22	187-7103	1	SUPPORT AS					
	23	8T-4136	2	BOLT (L=25mm)					
	24	179-7638	2	SWIVEL GP					
	25	8T-4176	8	BOLT (L=90mm)					
	26	187-7102	1	SUPPORT AS					
	27	196-0919	1	PIPE AS					
	28	9X-6032	4	BOLT (L=30mm)					

Y-SEE SEPARATE ILLUSTRATION

H75227E 02

168-9535 LINES GP-RETURN & FILTER (2/2)
171-0002-Page436

MEMORANDA

HYDRAULIC SYSTEM

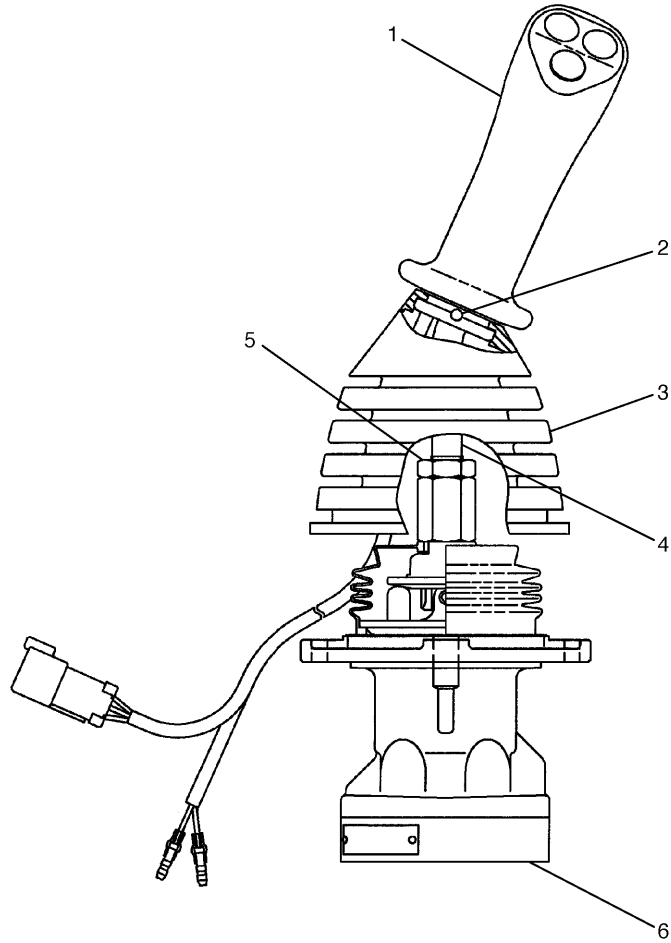

NOTE	No.	PART No.	QTY	PART NAME	NOTE	No.	PART No.	QTY	PART NAME
	1	187-9975	1	KNOB AS					
		102-8805	1	RECEPTACLE KIT					
		7Y-3962	2	TERMINAL					
		7Y-3964	2	TUBE					
		180-9339	6	PIN					
	2	139-0922	1	PIN					
	3	187-9908	1	BOOT					
	4	149-1572	1	LEVER					
	5	7Y-8463	1	NUT					
Y	6	165-9569	1	VALVE GP					

Y-SEE SEPARATE ILLUSTRATION

H79754E 00

187-9973 VALVE GP-PILOT
 Part of 165-0989-Page166
 165-9569-Page440
 An Attachment

HYDRAULIC SYSTEM

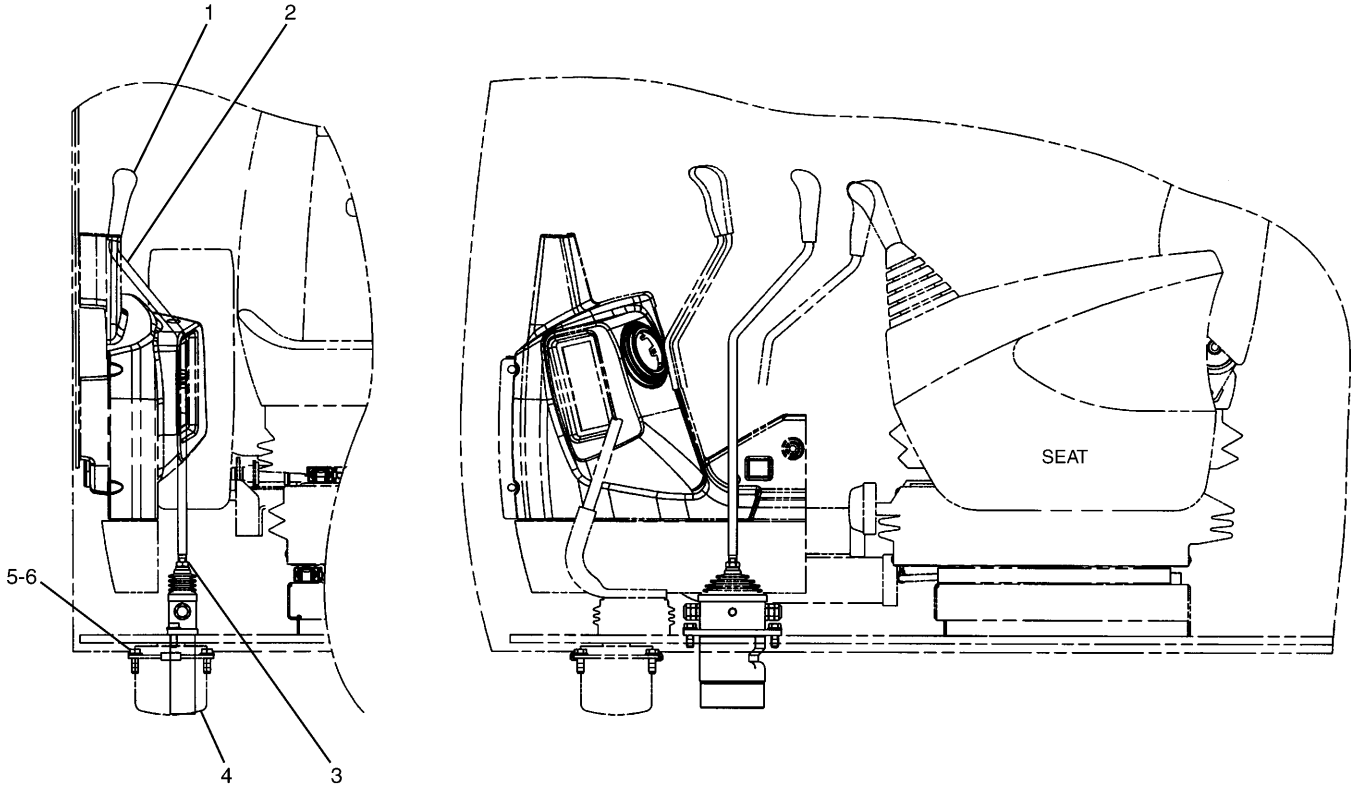

NOTE	No.	PART No.	QTY	PART NAME	NOTE	No.	PART No.	QTY	PART NAME
	1	110-5602	1	KNOB					
	2	189-2786	1	LEVER					
	3	096-6331	1	NUT					
Y	4	165-9582	1	VALVE GP					
	5	8T-4136	2	BOLT (L=25mm)					
	6	8T-4121	2	WASHER					

Y-SEE SEPARATE ILLUSTRATION

H71804E 01

171-7372 CONTROL GP-BLADE

Part of 151-1493-Page552,151-1494-Page553,183-1476-Page553.01
165-9582-Page390
An Attachment

HYDRAULIC SYSTEM

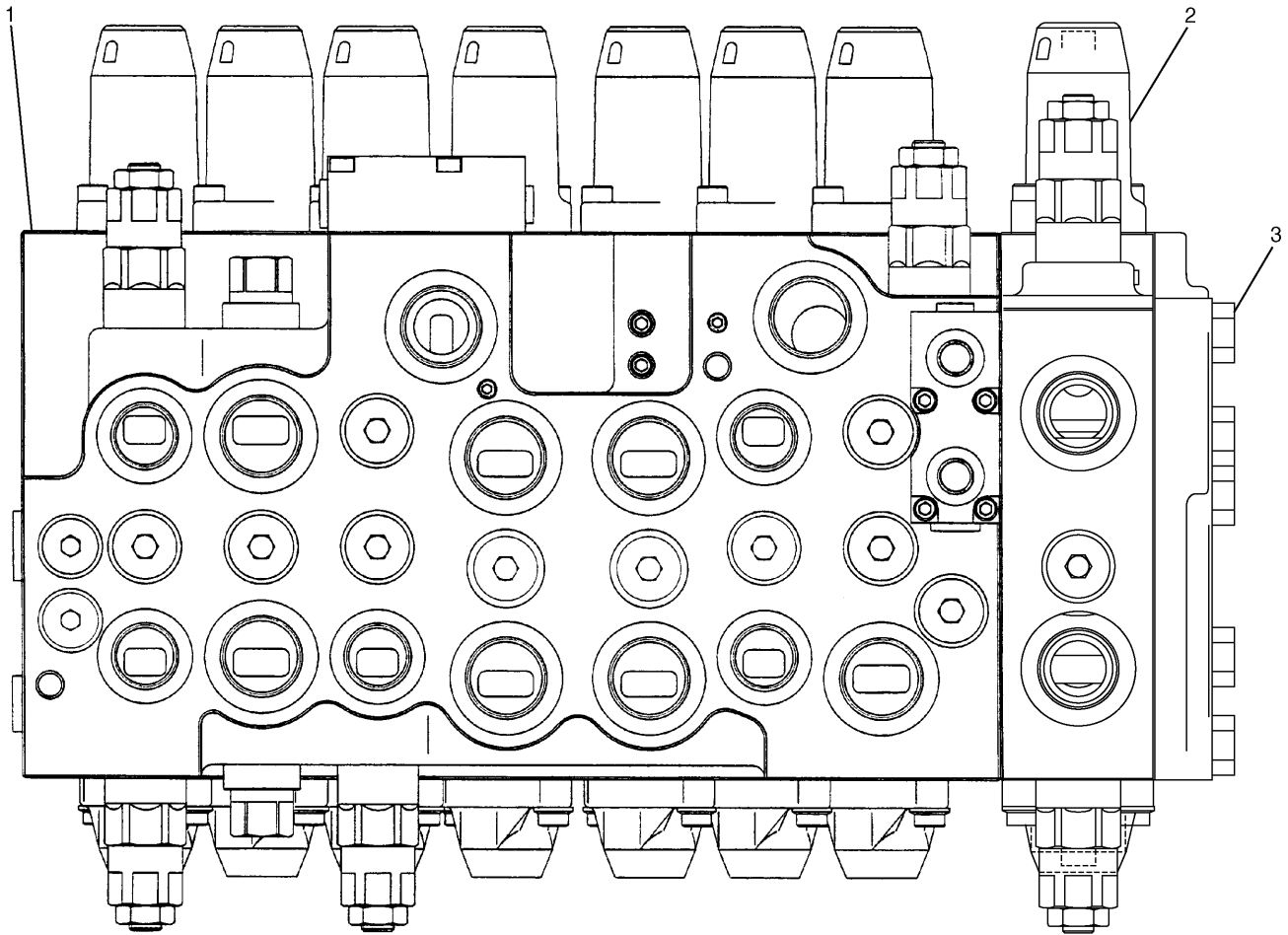

NOTE	No.	PART No.	QTY	PART NAME	NOTE	No.	PART No.	QTY	PART NAME
Y	1	171-0016	1	VALVE GP					
Y	2	171-0006	1	VALVE GP					
	3	177-2768	5	BOLT (L=105mm)					

Y-SEE SEPARATE ILLUSTRATION

H75236E 01

197-0200 VALVE & MOUNTING GP

Part of 165-0963-Page317,179-5071-Page318,165-0976-Page319
171-0016-Page402,171-0006-Page433
An Attachment

HYDRAULIC SYSTEM

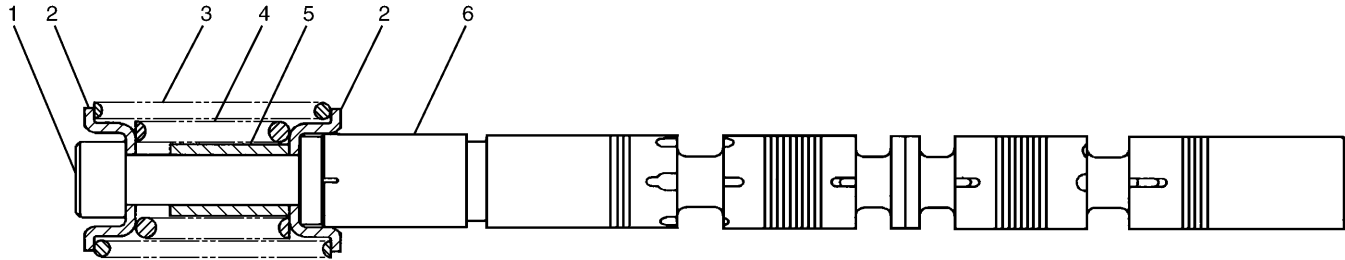

NOTE	No.	PART No.	QTY	PART NAME	NOTE	No.	PART No.	QTY	PART NAME
	1	197-0148	1	BOLT					
	2	71-7203	2	SEAT					
	3	197-0152	1	SPRING					
	4	197-0150	1	SPRING					
	5	197-0149	1	STOPPER					
	6	197-0214	1	SPOOL					

H72154E 00

197-0213 VALVE GP-CONTROL
Part of 171-0016-Page407

HYDRAULIC SYSTEM

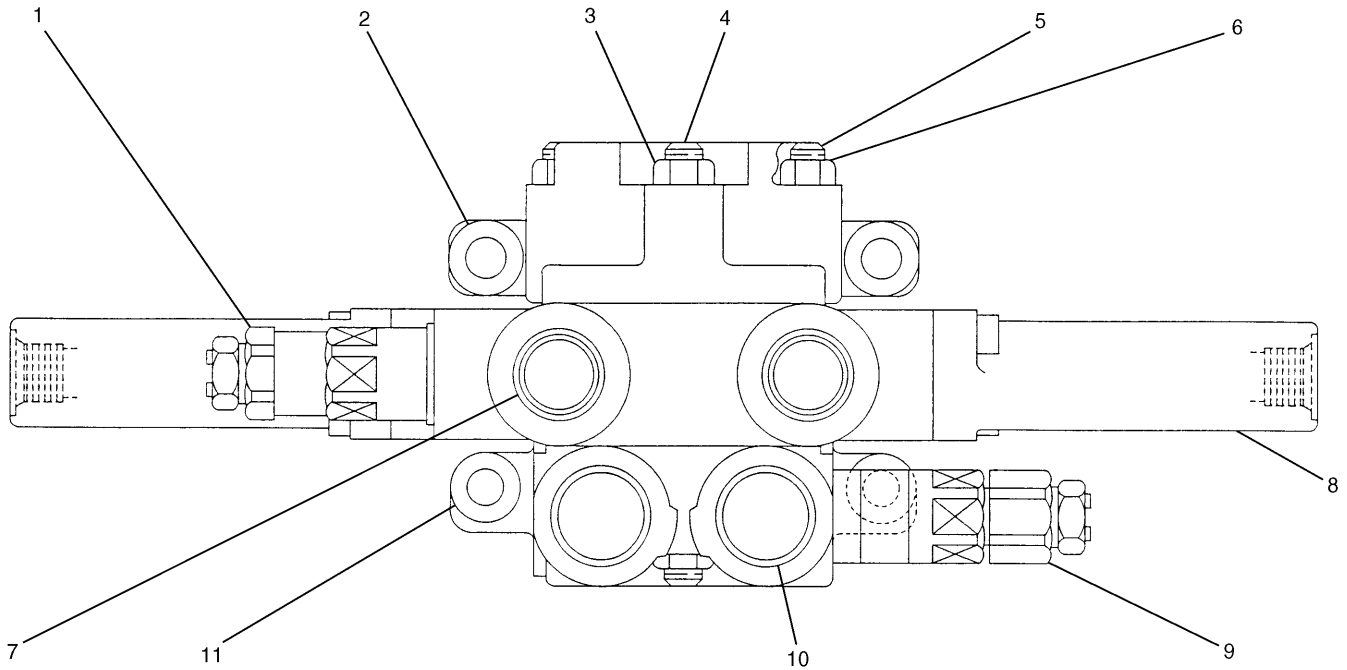

NOTE	No.	PART No.	QTY	PART NAME	NOTE	No.	PART No.	QTY	PART NAME
	1	125-7193	1	VALVE GP					
		2M-9780	1	SEAL-O-RING (ID=19.18mm)					
	2	099-3990	1	BODY					
	3	1R-6484	2	NUT					
	4	093-3093	1	ROD					
	5	093-3094	2	ROD					
	6	095-6636	4	NUT					
	7	71-0135	2	PLUG					
Y	8	122-5400	1	VALVE GP					
	9	125-7192	1	VALVE GP					
		2M-9780	1	SEAL-O-RING (ID=19.18mm)					
	10	71-0134	2	PLUG					
	11	122-5399	1	BODY					

Y-SEE SEPARATE ILLUSTRATION

H51350E 02

122-5373 VALVE GP-CONTROL

Part of 168-9555-Page285
122-5400-Page430
An Attachment

HYDRAULIC SYSTEM

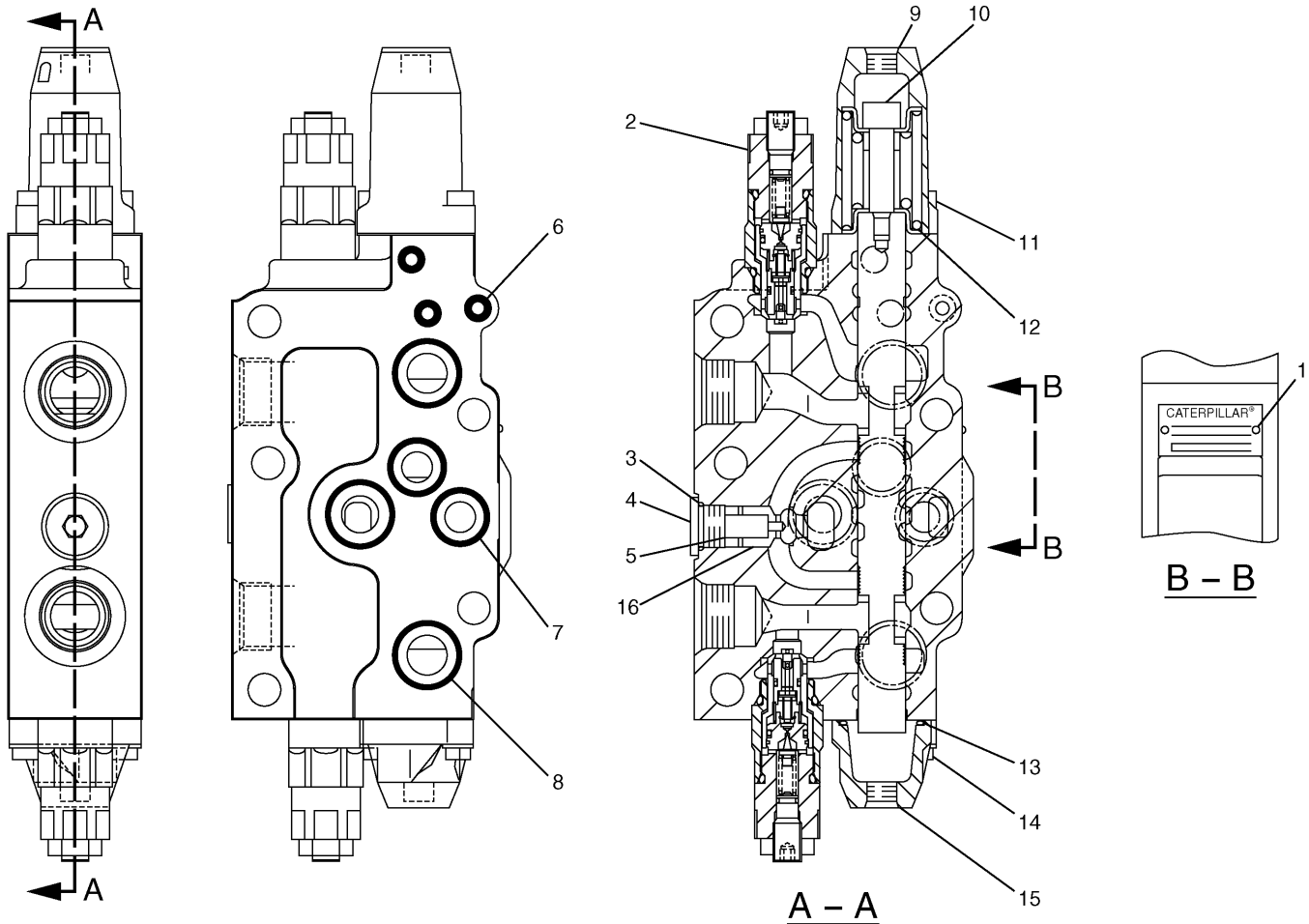

NOTE	No.	PART No.	QTY	PART NAME	NOTE	No.	PART No.	QTY	PART NAME
	1	5B-9304	2	SCREW					
Y	2	197-0223	2	VALVE GP					
	3	095-1586	1	SEAL-O-RING (ID=19.80mm)					
	4	71-7206	1	PLUG					
	5	71-7207	1	SPRING					
	6	095-1578	3	SEAL-O-RING (ID=9.80mm)					
	7	095-1696	2	SEAL-O-RING (ID=24.40mm)					
	8	095-1698	3	SEAL-O-RING (ID=29.40mm)					
	9	197-0170	1	COVER					
Y	10	197-0173	1	VALVE GP					
	11	5A-3604	2	BOLT (L=25mm)					
	12	71-7204	1	SEAL-O-RING (ID=35.80mm)					
	13	095-1700	1	SEAL-O-RING (ID=34.40mm)					
	14	197-0165	2	BOLT					
	15	197-0168	1	COVER					
	16	71-7208	1	VALVE					

Y-SEE SEPARATE ILLUSTRATION

H72136E 02

171-0006 VALVE GP-CONTROL
 Part of 197-0201-Page398,197-0200-Page399
 197-0173-Page414,197-0223-Page423
 An Attachment

HYDRAULIC SYSTEM

NOTE	No.	PART No.	QTY	PART NAME	NOTE	No.	PART No.	QTY	PART NAME
	1	9S-8005	3	PLUG					
	2	197-0273	1	SPRING					
	3	197-0199	1	SPRING					
Y	4	121-1491	3	VALVE GP					
	5	3K-0360	3	SEAL-O-RING (ID=16.36mm)					
	6	71-2272	6	BOLT (L=12mm)					
	7	7M-7410	2	PLUG					
	8	197-0196	1	VALVE					
	9	8T-6759	6	PLUG					
	10	4B-4158	2	SCREW					

Y-SEE SEPARATE ILLUSTRATION

H74549E 04

158-8251 VALVE GP-SELECTOR
 Part of 168-9538-Page323
 121-1491-Page435

HYDRAULIC SYSTEM

NOTE	No.	PART No.	QTY	PART NAME	NOTE	No.	PART No.	QTY	PART NAME
	1	201-9285	1	SEAT					
	2	095-1573	1	SEAL-O-RING (ID=5.80mm)					
	3	201-9287	1	SPRING					
	4	201-9291	1	VALVE					
	5	095-1590	1	SEAL-O-RING (ID=21.80mm)					
	6	71-8084	6	PLUG					
	7	5B-9304	2	SCREW					
	8	201-9283	1	SEAT AS					
	9	201-9293	1	PLUG					
	10	095-1584	3	SEAL-O-RING (ID=15.80mm)					
	11	201-9284	1	PISTON					
	12	71-7235	1	PLUG					
	13	095-1592	2	SEAL-O-RING (ID=23.70mm)					
	14	201-9292	1	VALVE AS					
	15	201-9288	1	SPRING					
	16	201-9294	1	PLUG					
	17	201-9296	1	PLUG					
	18	201-9289	1	SPRING					
	19	095-1589	1	SEAL-O-RING (ID=21.70mm)					
	20	201-9286	1	SPOOL AS					
	21	201-9295	1	PLUG					
	22	201-9330	1	NUT					
	23	201-9331	1	SCREW					

H86455E 01

190-7830 VALVE GP-PILOT
 Part of 168-9560-Page279.02
 An Attachment

HYDRAULIC SYSTEM

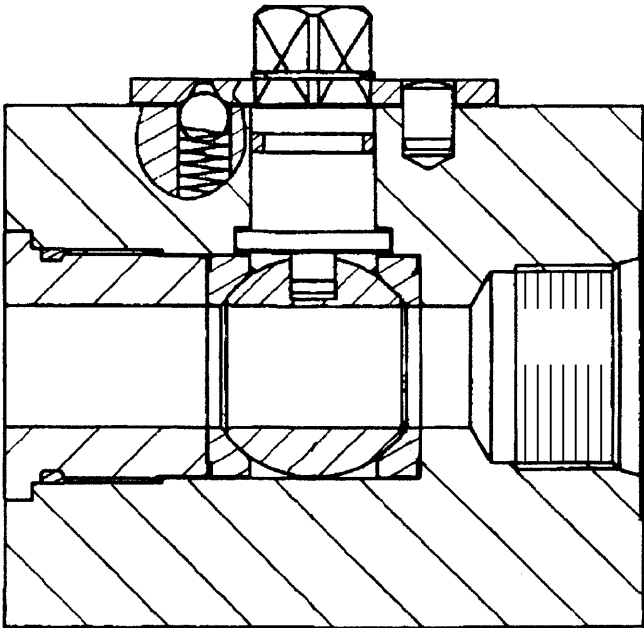
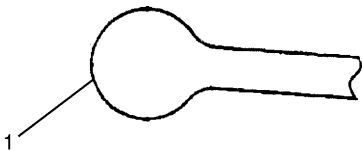

NOTE	No.	PART No.	QTY	PART NAME	NOTE	No.	PART No.	QTY	PART NAME
	1	119-9447	1	HANDLE					

H84240E 00

230-0363 VALVE AS-BALL
 Part of 146-1464-Page448.01
 An Attachment

OPERATOR STATION

NOTE	No.	PART No.	QTY	PART NAME	NOTE	No.	PART No.	QTY	PART NAME
Y	1	167-6976	1	HATCH GP					
Y	2	189-2768	1	DOOR GP					
Y	3	139-7101	1	WINDOW GP					
	4	8T-4121	6	WASHER					
Y	5	171-7408	1	WIPER GP					
Y	6	176-1958	1	WINDOW GP					
Y	7	185-8277	1	CAB GP					
Y	8	176-1981	1	CAB GP					
Y	9	185-8279	1	WINDOW GP					
	10	8T-4136	6	BOLT (L=25mm)					

Y-SEE SEPARATE ILLUSTRATION

H71007E 04

171-7346 CAB GP (BASIC)

Part of 171-7345-Page450,189-3446-Page452

176-1981-Page462,185-8277-Page466,189-2768-Page470,167-6976-Page474,139-7101-Page476,185-8279-Page482
,176-1958-Page483,171-7408-Page484

An Attachment

OPERATOR STATION

NOTE	No.	PART No.	QTY	PART NAME	NOTE	No.	PART No.	QTY	PART NAME
	1	1R-5998	2	LOCKWASHER		54	085-6452	2	WASHER
	2	3B-4510	1	LOCKWASHER		55	164-0664	1	BRACKET
	3	4B-4278	3	WASHER		56	176-1941	1	PIN
	4	4I-1205	2	BUMPER		57	185-8280	1	WASHER
	5	4I-1206	2	GUIDE		58	185-8281	1	SPRING
	6	4I-1278	1	FILTER					
	7	4I-3063	1	SPRING					
	8	4I-3144	2	WASHER					
	9	4I-4270	1	HOLDER					
	10	4I-4392	3	CLIP					
	11	5C-7793	1	HOOK					
E	12	6I-5470		SEAL... (150cm)					
	13	6V-7636	4	PIN AS					
	14	8T-4133	5	NUT					
	15	099-0823	3	SCREW					
	16	099-7127	2	SCREW					
	17	8T-4200	3	BOLT (L=16mm)					
	18	127-0580	2	SCREW					
	19	139-7126	1	HOLDER					
	20	139-7127	1	HOLDER					
	21	156-6596	1	HANDLE AS					
	22	156-6599	1	STRIKER					
	23	156-6617	1	MIRROR					
	24	156-6618	1	SUPPORT AS					
	25	161-3660	1	BRACKET AS					
	26	161-3685	1	ROD					
	27	161-3690	1	HANDLE AS					
	28	161-3697	1	GUARD					
	29	164-0523	1	LEVER AS					
	30	164-0527	1	ROD					
	31	156-6642	1	LEVER AS					
	32	167-7042	2	SEAL					
	33	171-7396	1	COVER AS					
	34	171-7426	1	CABLE AS					
	35	176-1938	1	LEVER					
	36	176-1942	1	COVER					
	37	176-1973	1	LATCH AS					
	38	189-2894	2	BOLT					
	39	176-1986	1	LIGHT					
	40	178-5570	2	GROMMET					
	41	133-8016	1	PACKING					
	42	3E-8020	3	SCREW					
	43	8T-4137	2	BOLT (L=20mm)					
	44	7X-0578	2	WASHER					
	45	8T-4193	1	BOLT (L=50mm)					
	46	9X-2041	3	SCREW					
	47	9X-2042	5	SCREW					
	48	9X-2044	5	SCREW					
	49	9X-2045	2	SCREW					
	50	9X-2046	4	SCREW					
	51	9X-8257	1	WASHER					
	52	8T-4224	6	WASHER					
	53	176-1937	1	BRACKET AS					

E--ORDER BY THE CENTIMETER

H70414E 01

185-8277 CAB GP-EXTERIOR

Part of 139-7092-Page455,171-7346-Page457,164-0556-Page459
An Attachment

OPERATOR STATION

NOTE	No.	PART No.	QTY	PART NAME	NOTE	No.	PART No.	QTY	PART NAME
	1	117-6306	1	SWITCH					
	2	151-6703	1	HANDLE					
	3	151-6704	2	CAP					
	4	095-0827	2	LOCKWASHER					
	5	151-6785	1	BRACKET AS					
	6	151-6813	1	BRACKET AS					
	7	151-6815	1	BRACKET AS					
	8	151-6818	1	LINK AS					
	9	151-6819	1	LINK AS					
	10	151-6831	1	LOCK AS					
	11	151-6832	1	LEVER AS					
	12	151-6844	1	COVER					
	13	151-9557	2	STOPPER					
	14	156-6472	1	GLASS					
	15	156-6554	1	CABLE AS					
	16	156-6555	1	STRIKER AS					
	17	156-6562	1	BRACKET					
	18	156-6563	1	CATCH AS					
	19	156-6579	1	STOPPER					
	20	156-6601	1	SEAL AS					
		156-6602	1	SEAL					
		156-6603	20	CLIP					
	21	156-6627	1	STOPPER AS					
	22	161-3684	2	STOPPER					
	23	161-3698	1	SEAL					
	24	164-0648	1	BRACKET AS					
	25	170-9722	1	CUSHION					
	26	099-0823	2	SCREW					
	27	095-0742	2	SCREW					
	28	151-9576	4	ROLLER					
	29	5C-8312	1	NUT					
	30	6V-5210	2	SCREW					
	31	6V-5683	2	BOLT (L=16mm)					
	32	8T-4121	4	WASHER					
	33	8T-4137	4	BOLT (L=20mm)					
	34	9X-2042	18	SCREW					
	35	9X-2044	5	SCREW					
	36	9X-2045	4	SCREW					

H70123E 02

139-7101 WINDOW GP
 Part of 139-7092-Page455,171-7346-Page457
 An Attachment

OPERATOR STATION

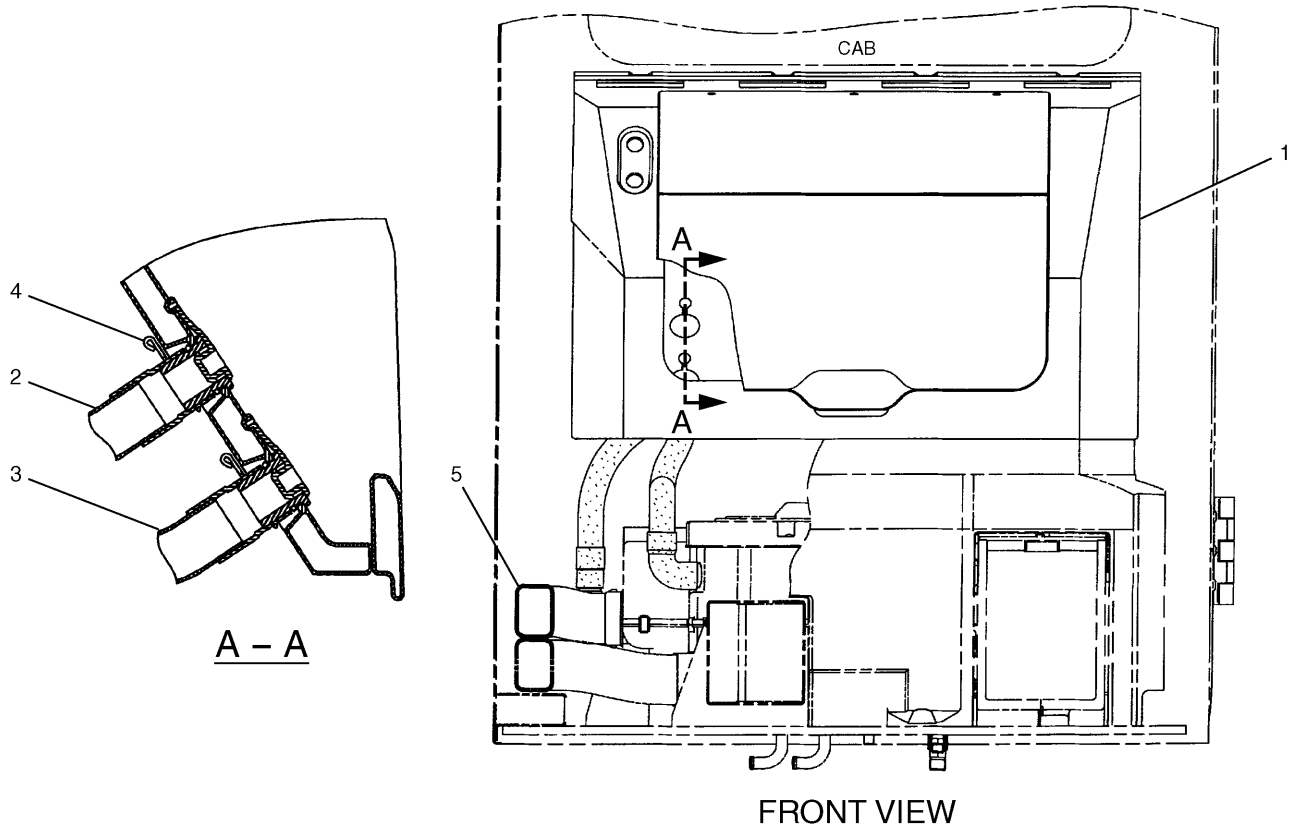

NOTE	No.	PART No.	QTY	PART NAME	NOTE	No.	PART No.	QTY	PART NAME	
Y	1	196-1422	1	COVER GP						
	2	189-3462	1	HOSE						
	3	167-7110	1	HOSE						
	4	167-7114	4	CLAMP						
	5	189-3477	1	DUCT AS						
			189-3463	1	PIPE					
			095-1531	2	SEAL-O-RING (ID=29.70mm)					
			189-3415	1	INSULATOR					

Y-SEE SEPARATE ILLUSTRATION

H77619E 01

196-1420 COVER GP
 196-1422-Page487.01
 An Attachment

OPERATOR STATION

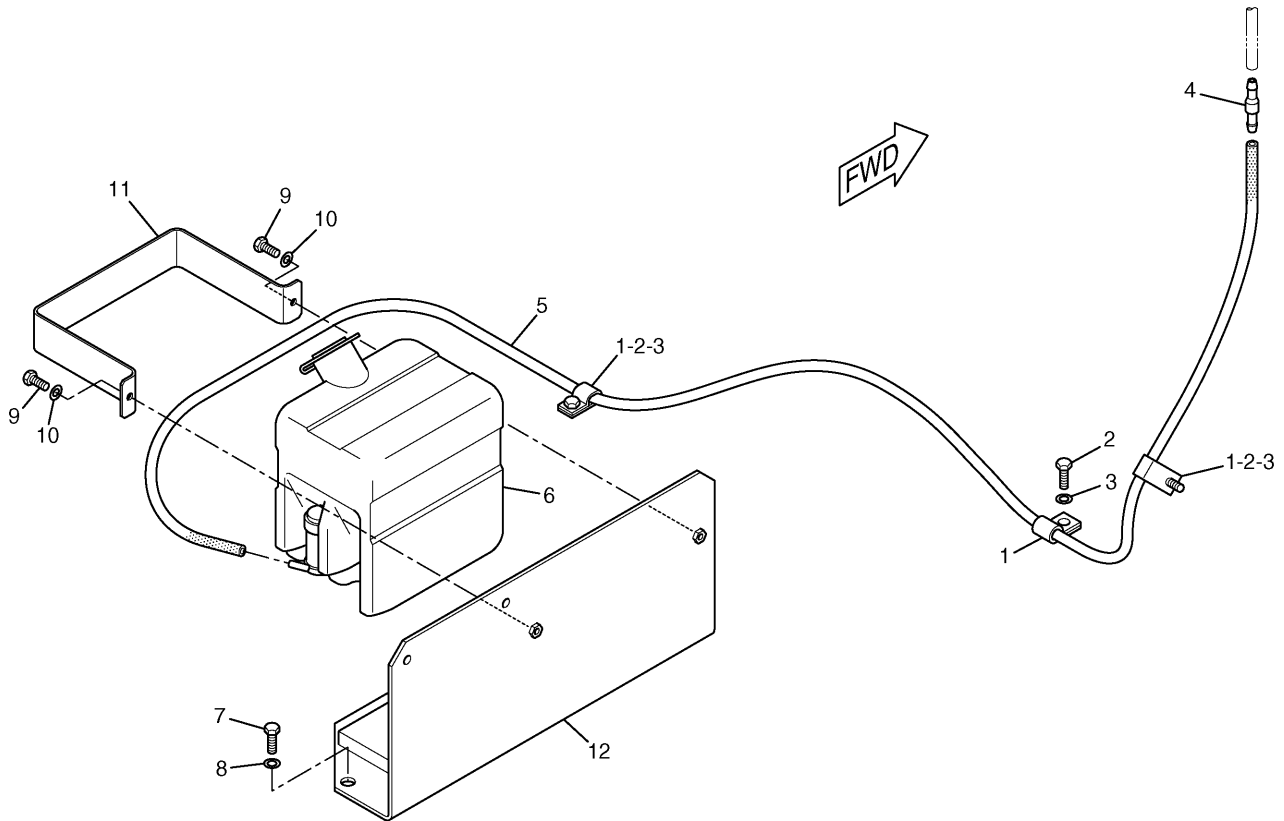

NOTE	No.	PART No.	QTY	PART NAME	NOTE	No.	PART No.	QTY	PART NAME
	1	6 V-3 2 6 5	3	CLIP					
	2	8 T-4 1 3 7	3	BOLT (L=20mm)					
	3	8 T-4 1 2 1	3	WASHER					
	4	7 Y-3 4 7 4	1	VALVE AS					
E	5	1 4 4-0 1 9 5		HOSE...(190cm)					
Y	6	1 7 6-1 9 3 1	1	TANK AS					
	7	8 T-4 1 9 2	2	BOLT (L=25mm)					
	8	8 T-4 2 2 3	2	WASHER					
	9	8 T-4 9 7 0	2	BOLT (L=14mm)					
	10	9 X-8 2 5 6	2	WASHER					
	11	1 7 6-1 9 9 5	1	SUPPORT					
	12	1 8 9-2 8 1 0	1	BRACKET AS					

E—ORDER BY THE CENTIMETER
Y—SEE SEPARATE ILLUSTRATION

H77608E 02

MEMORANDA

OPERATOR STATION

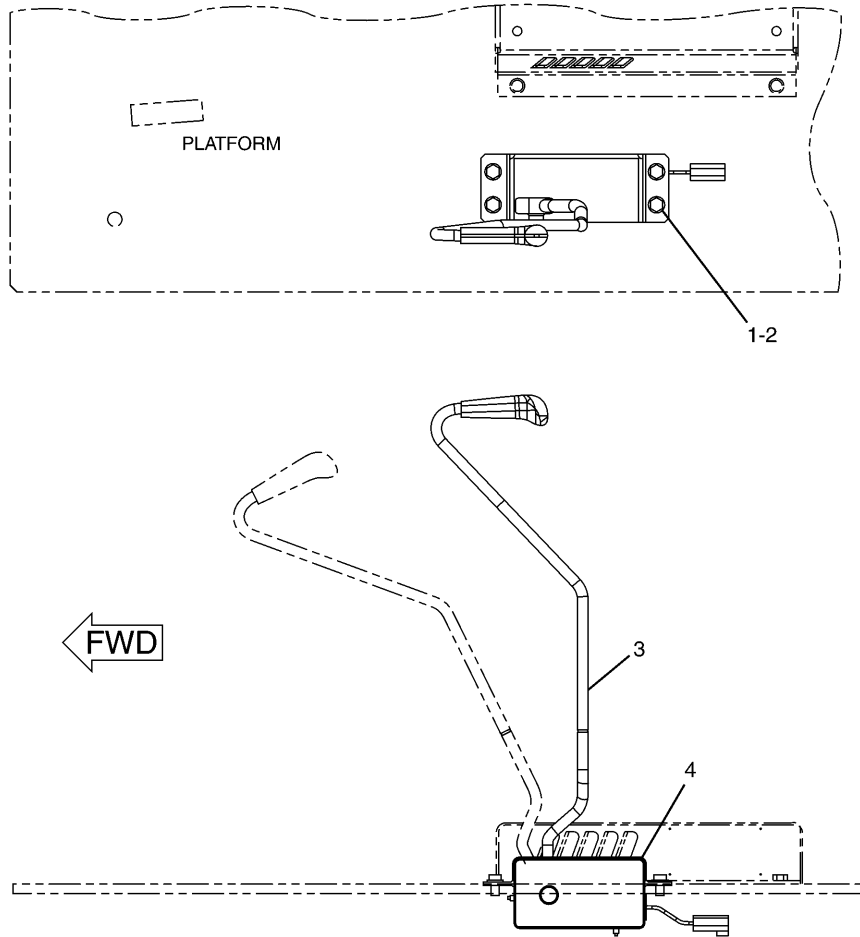

NOTE	No.	PART No.	QTY	PART NAME	NOTE	No.	PART No.	QTY	PART NAME
Y	1	8 T - 4 1 3 7	4	BOLT (L=20mm)					
	2	8 T - 4 1 2 1	4	WASHER					
	3	1 6 7 - 7 0 8 0	1	LEVER GP					
	4	1 7 8 - 5 5 0 8	1	COVER					

Y-SEE SEPARATE ILLUSTRATION

H73544E 06

161-3752 LEVER GP
167-7080-Page512

OPERATOR STATION

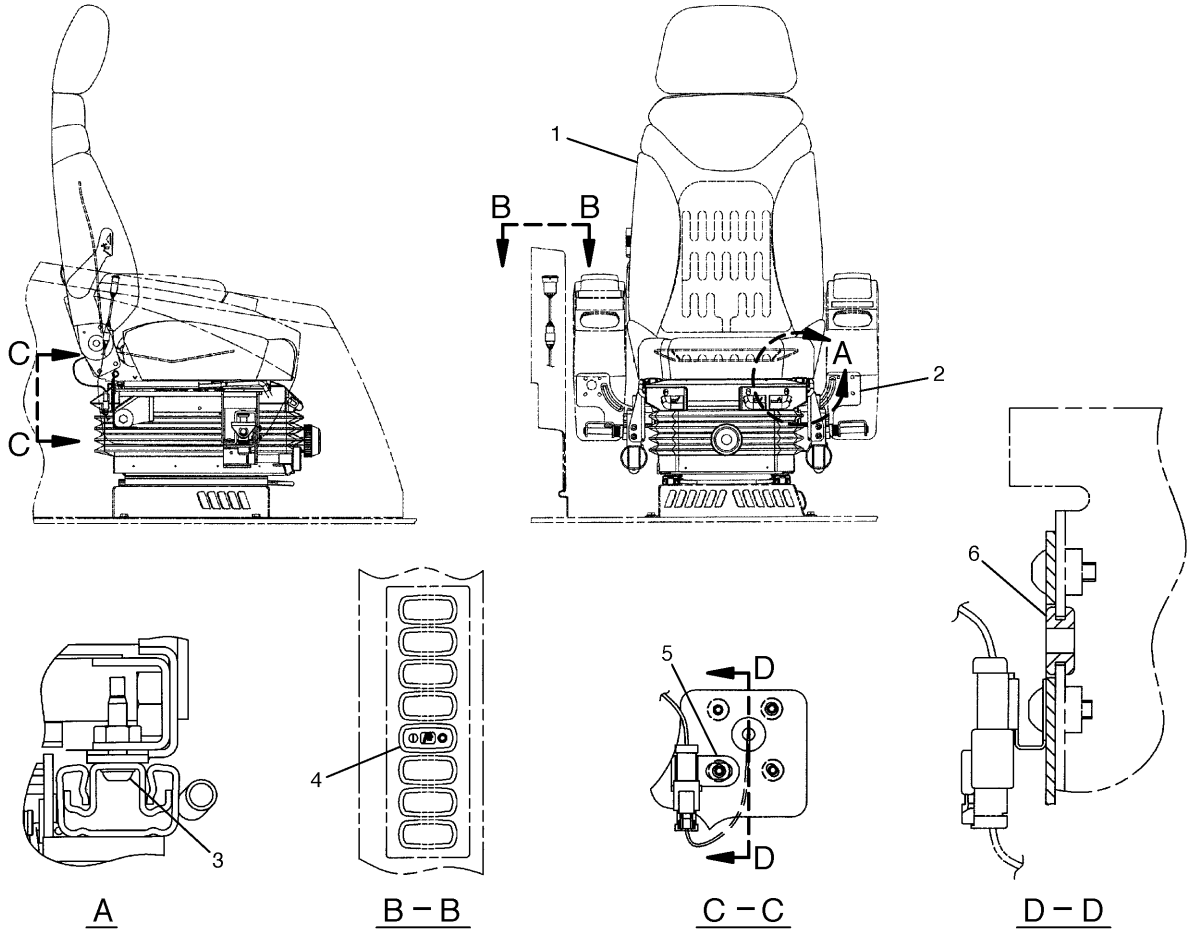

NOTE	No.	PART No.	QTY	PART NAME	NOTE	No.	PART No.	QTY	PART NAME
Y	1	164-0505	1	SEAT GP					
		178-5660	1	HANDLE KIT (RECLINER)					
		178-5659	1	HANDLE KIT (ADJUSTER)					
	2	164-0503	1	SUSPENSION GP					
	3	178-5565	4	SCREW					
	4	163-6721	1	SWITCH AS					
		167-3542	1	CONNECTOR					
		167-3543	4	TERMINAL					
	5	116-0118	1	CLIP					
	6	9D-8508	1	GROMMET					

Y-SEE SEPARATE ILLUSTRATION

H71334E 04

164-0502 SEAT GP
164-0503-Page522
An Attachment

OPERATOR STATION

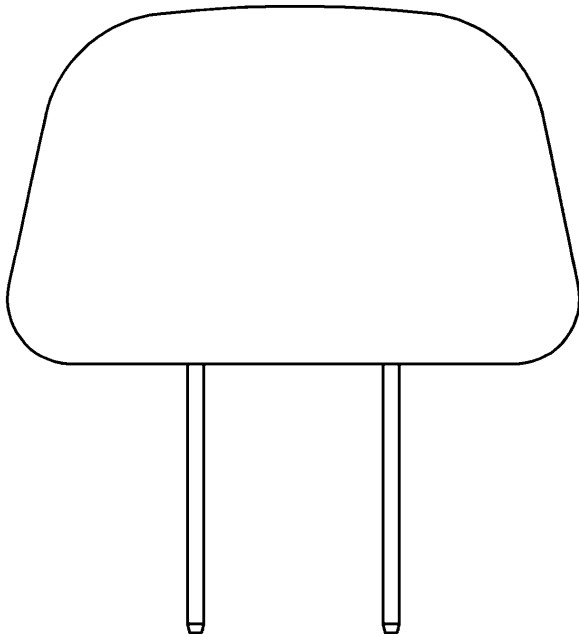

NOTE	No.	PART No.	QTY	PART NAME

H71339E 03

164-0477 HEADREST AS
An Attachment

MEMORANDA

OPERATOR STATION

NOTE	No.	PART No.	QTY	PART NAME	NOTE	No.	PART No.	QTY	PART NAME
	1	095-0913	2	CLIP					
	2	8T-4189	1	BOLT (L=20mm)					
	3	8T-4224	3	WASHER					
	4	207-0145	1	SUPPORT AS					
	5	8T-3647	2	BOLT (L=80mm)					
	6	5D-1026	4	CLAMP					
	7	8T-4137	2	BOLT (L=20mm)					
	8	8T-4121	2	WASHER					
	9	6D-1641	2	CLIP					
	10	155-7024	2	SPACER					
	11	178-5425	1	ELBOW					
E	12	5P-0767		HOSE...(260cm)					
	13	7Y-8168	1	GROMMET					
	14	4I-4580	1	NIPPLE					
	15	096-0061	1	STRAP					
E	16	5P-0767		HOSE...(225cm)					

E—ORDER BY THE CENTIMETER

H77612E 02

170-9715 LINES GP-HEATER
 Part of 196-1609-Page539
 An Attachment

IMPLEMENTS

Consists of :

			Page
1	165-9424	CYLINDER & LINES GP-BUCKET.....	266
1	195-5360	LINKAGE GP-BUCKET.....	570

H75254E 00

194-8947 LINKAGE AR-BUCKET
An Attachment

IMPLEMENTS

NOTE	No.	PART No.	QTY	PART NAME	NOTE	No.	PART No.	QTY	PART NAME
	1	093-0357	1	WASHER					
	2	166-1494	2	SEAL					
	3	172-3080	1	PIN					
	4	095-6824	2	PLATE					
	5	8T-4192	4	BOLT (L=25mm)					
	6	099-3600	4	WASHER					
	7	8T-4179	1	BOLT (L=20mm)					
	8	086-0297	1	WASHER					
	9	1R-6225	1	PIN AS					
	10	166-1486	4	SHIM (T=2.00mm)					
B	11	093-0115	1	SHIM (T=2.00mm)					
B		133-2425	1	SHIM (T=0.50mm)					
	12	4I-3309	2	SPACER					
	13	1R-6226	1	PIN AS					
	14	7X-2552	1	BOLT (L=30mm)					
	15	086-0298	1	WASHER					
	16	8T-6764	2	PLUG					
	17	173-7914	1	BOOM AS					
	18	168-0062	2	BEARING					
	19	113-2276	1	MANIFOLD					
	20	7I-6845	6	PLATE					
	21	7I-6846	1	PLATE					
	22	7Y-2579	2	BAR					

B-USE AS REQUIRED

H75259E 02

179-5076 BOOM GP
Part of 179-5075-Page292
An Attachment

IMPLEMENTS

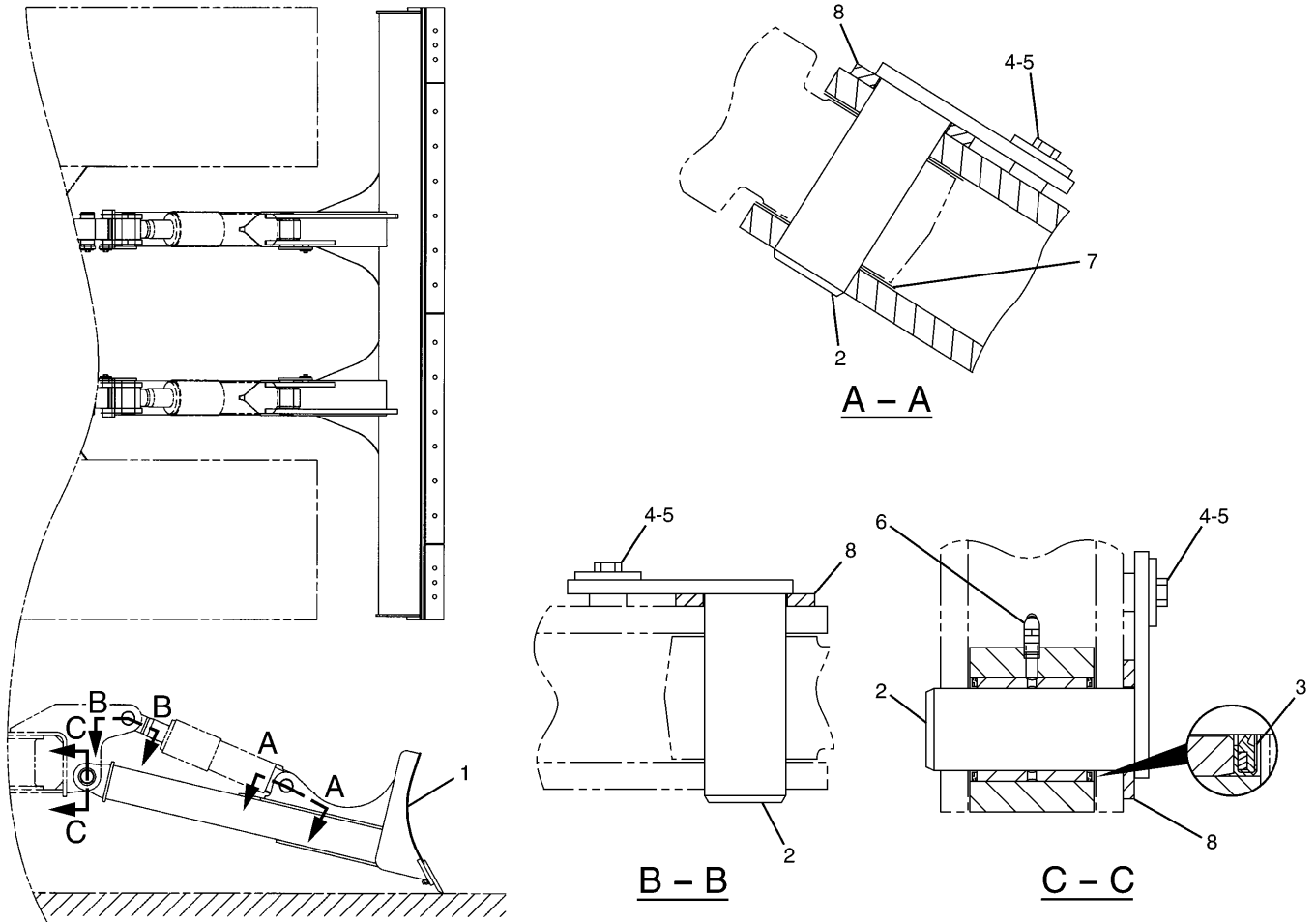

NOTE	No.	PART No.	QTY	PART NAME	NOTE	No.	PART No.	QTY	PART NAME
Y	1	172-2991	1	BLADE GP					
	2	127-3913	6	PIN AS					
	3	093-1433	4	SEAL					
	4	8T-4179	6	BOLT (L=20mm)					
	5	086-0297	6	WASHER					
	6	3J-7283	2	FITTING					
	B	7	093-0065	8	SHIM (T=1.00mm)				
	B		099-7091	4	SHIM (T=1.50mm)				
B		093-0097	4	SHIM (T=2.00mm)					
	8	093-0357	6	WASHER					

B-USE AS REQUIRED

Y-SEE SEPARATE ILLUSTRATION

H72039E 02

167-9991 BLADE & MOUNTING GP
 Part of 151-1493-Page552
 172-2991-Page565
 An Attachment

IMPLEMENTS

Consists of :

			Page
1	198-5738	LINKAGE GP-BUCKET.....	569.01
		-OR-	
1	198-5739	LINKAGE GP-BUCKET.....	569.02

H82867E 02

168-0014 LINKAGE GP-BUCKET
Part of 151-1491-Page551
An Attachment

IMPLEMENTS

Consists of :

			Page
1	41-7343	SIDECUTTER GP.....	587
1	150-2247	BUCKET & ADJUSTER GP.....	577
5	9J-3169	TIP GP-LONG.....	587

H60273E 00

150-2241 BUCKET AR An Attachment

Consists of :

			Page
1	41-7343	SIDECUTTER GP.....	587
1	150-2248	BUCKET & ADJUSTER GP.....	578
5	9J-3169	TIP GP-LONG.....	587

H60274E 00

150-2242 BUCKET AR An Attachment

IMPLEMENTS

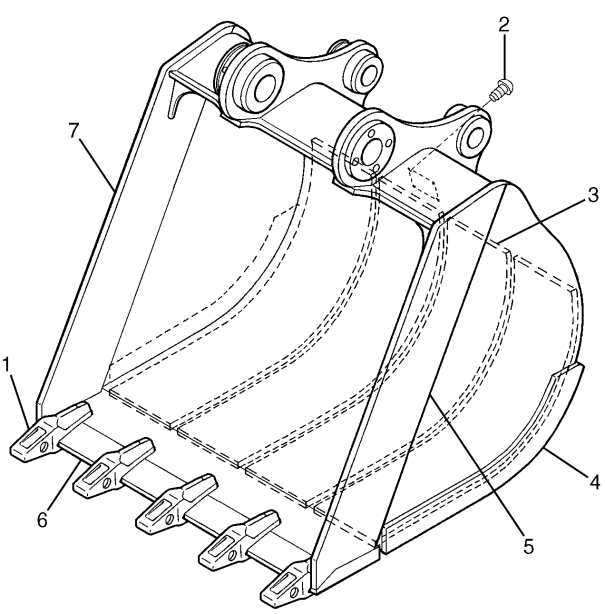
	NOTE	No.	PART No.	QTY	PART NAME
	B	1	7Y-0254	5	ADAPTER
		2	4B-4158	4	SCREW
		3	108-9041	4	PLATE
		4	71-6823	2	PLATE
		5	102-3191	1	PLATE
		6	086-0813	1	EDGE
		7	102-3190	1	PLATE
B-USE AS REQUIRED					
					H72196E 02

154-0618 BUCKET AS
 1000MM Wide—0.57Cu.M.—Adapter Size J250
 Part of 150-2249—Page578
 An Attachment

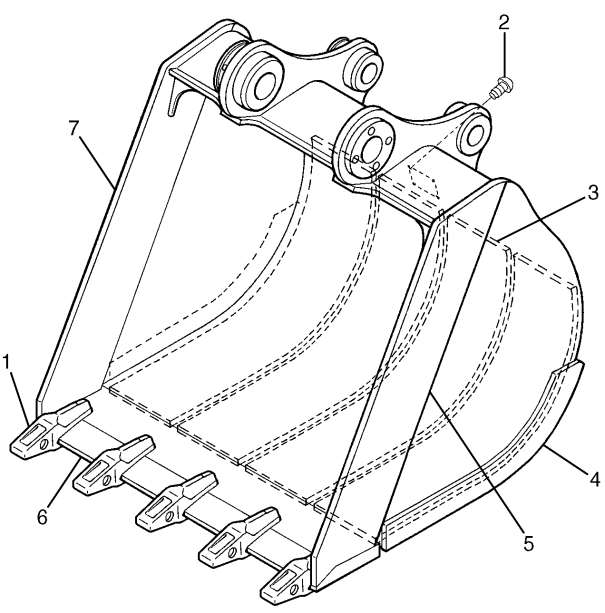
	NOTE	No.	PART No.	QTY	PART NAME
	B	1	7Y-0254	5	ADAPTER
		2	4B-4158	4	SCREW
		3	108-9042	4	PLATE
		4	71-6823	2	PLATE
		5	102-3191	1	PLATE
		6	086-0814	1	EDGE
		7	102-3190	1	PLATE
B-USE AS REQUIRED					
					H72197E 02

154-0619 BUCKET AS
 1090MM Wide—0.63Cu.M.—Adapter Size J250
 Part of 150-2250—Page579
 An Attachment

SERVICE EQUIPMENT AND SUPPLIES

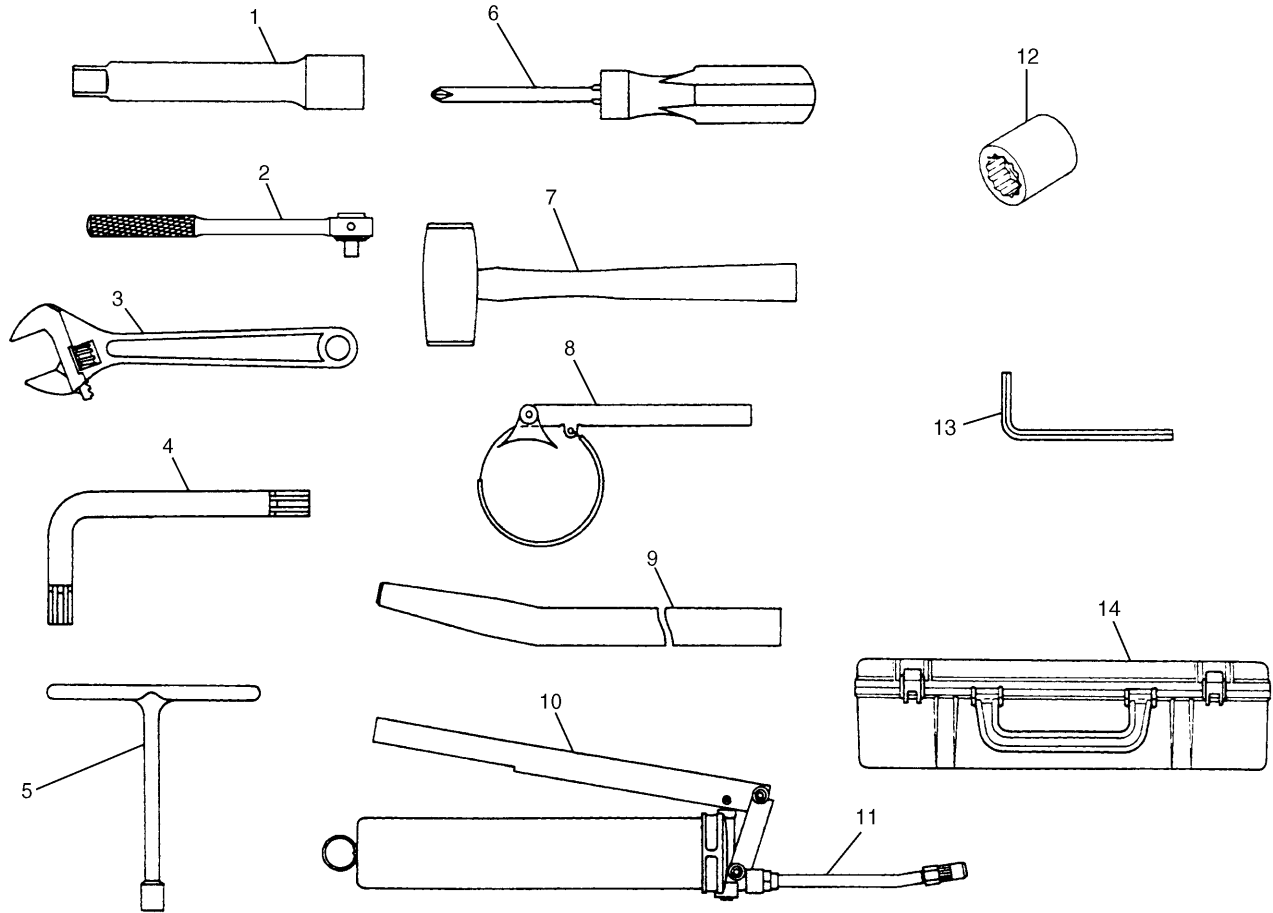

NOTE	No.	PART No.	QTY	PART NAME	NOTE	No.	PART No.	QTY	PART NAME
	1	099-3250	1	EXTENSION		12	095-1066	1	SOCKET (13MM)
	2	095-1852	1	RATCHET			099-3248	1	SOCKET (16MM)
	3	71-6395	1	WRENCH (200MM)			099-3249	1	SOCKET (18MM)
	4	41-2604	1	WRENCH (6MM)			095-1070	1	SOCKET (22MM)
		41-2605	1	WRENCH (10MM)			096-8251	1	SOCKET (30MM)
	5	7Y-6108	1	WRENCH (11MM)		13	095-1083	1	WRENCH (12MM)
	6	095-1855	1	SCREWDRIVER		14	7Y-0070	1	TOOLBOX
	7	095-1857	1	HAMMER					
	8	2P-8250	1	WRENCH AS					
		1P-0551	1	PIN					
		2P-8253	1	STRAP					
		6H-7378	1	RING					
	9	093-7638	1	BAR					
	10	099-7464	1	GREASE GUN					
	11	199-7371	1	TUBE AS					
A		4Y-0426	1	GREASE (BELLOWS)					
A		3Y-7597	1	GREASE (FOR WINTER TIME)					
A		1P-0808	1	GREASE (PAPER TUBE)					

A-NOT PART OF THIS GROUP

H71814E 01

169-7721 TOOL GP
Part of 169-7722-Page592
An Attachment

SERVICE EQUIPMENT AND SUPPLIES

NOTE	No.	PART No.	QTY	PART NAME	NOTE	No.	PART No.	QTY	PART NAME
	1	160-6853	2	FILM (DANGER)					
	2	132-4100	1	FILM (CAT)					
	3	186-1147	2	FILM (REGA)					
	4	105-7545	2	FILM (CAT)					
E	5	134-6146		FILM (STRIPE)···(350cm)					
	6	1P-2807	4	FILM (LIFT)					
	7	160-6832	2	FILM (WARNING)					
	8	169-7617	1	FILM (312C)					
	9	132-4099	1	FILM (CAT)					
	10	167-7272	1	FILM (CAT)					
	11	150-8108	1	FILM (CAT)					
	12	160-6884	1	FILM (DANGER)					
Z	13		1	PLATE (PIN)					
	14	4B-4158	4	SCREW					
	15	144-9126	1	FILM (INSTRUCTION)					
	16	7X-7644	1	FILM (TIE DOWN)					
	17	190-5386	2	FILM (SAFETY)					
	18	169-7616	1	FILM (NOTICE)					

E—ORDER BY THE CENTIMETER
 Z—NOT SERVICED

H75284E 05

151-1482 PLATE & FILM GP (2/3)
 S/N CAE 00492-Up

SERVICE EQUIPMENT AND SUPPLIES

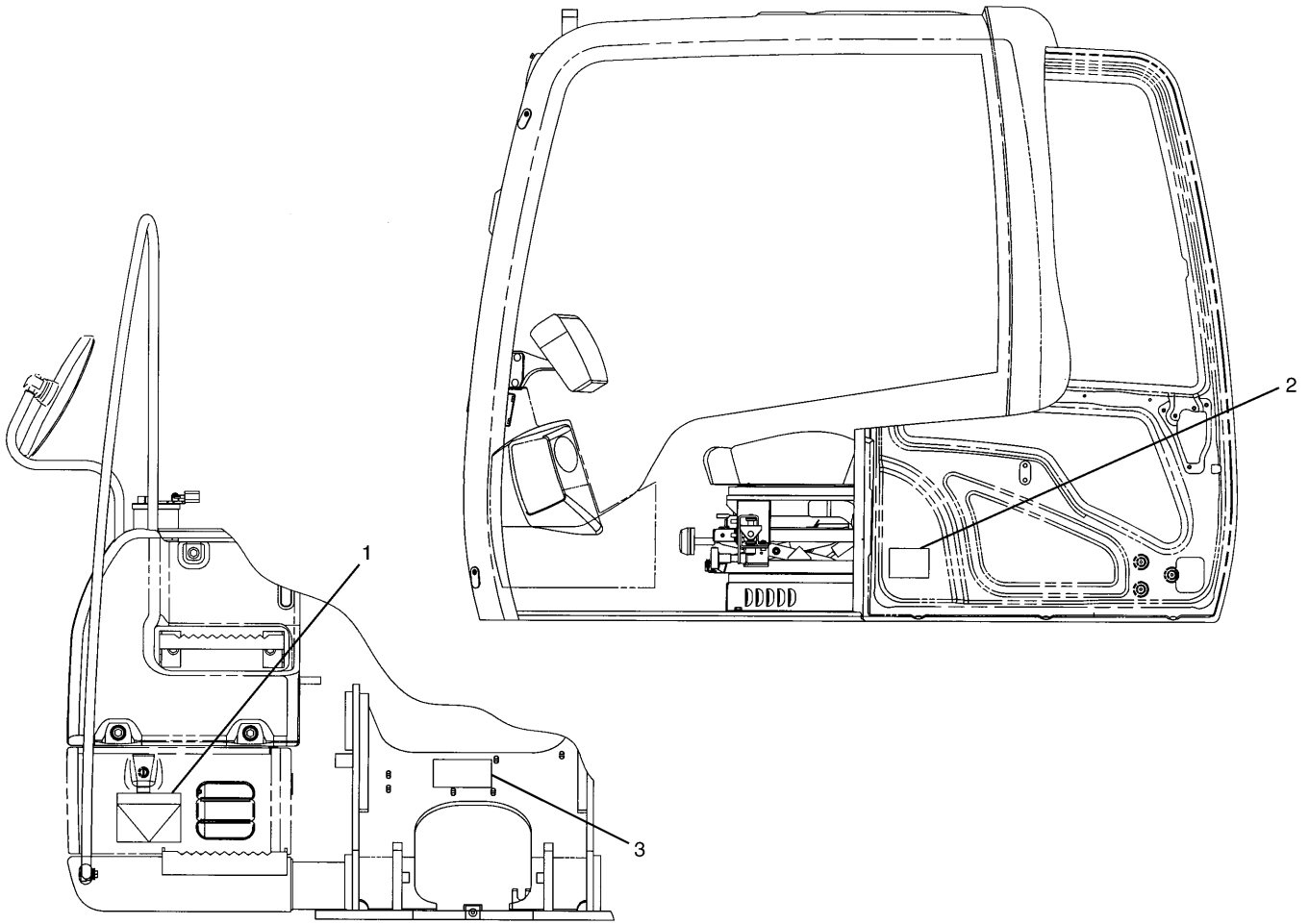

NOTE	No.	PART No.	QTY	PART NAME	NOTE	No.	PART No.	QTY	PART NAME
	1	127-5277	1	FILM (DEMOLITION)					
	2	194-8942	1	FILM					
	3	194-8943	1	FILM (NOTICE)					

H72071E 00

194-8941 FILM GP
Part of 194-8945-Page11
An Attachment

PART NUMBER INDEX

Part.No	Page	Part.No	Page	Part.No	Page
51-7611	21	51-7718	14	51-7896	22
51-7622	15	51-7719	15	51-7904	17
51-7623	31	51-7720	15	51-7905	17
51-7624	15	51-7721	15	51-7933	59
51-7625	15	51-7722	15	51-7939	60
51-7627	19	51-7723	19	51-7940	60
51-7630	15	51-7724	16		61
51-7631	15	51-7728	44	51-7941	60
51-7632	22	51-7735	44	51-7942	60
51-7633	54	51-7738	15	51-7947	68
	59	51-7739	15	51-7978	16
51-7636	16	51-7740	15	51-8005	16
51-7637	20	51-7743	68	51-8009	16
51-7638	24	51-7746	58	51-8010	44
51-7639	54	51-7750	26	51-8011	14
51-7640	28	51-7762	12	51-8012	14
51-7642	28		24	51-8013	59
51-7643	28	51-7784	16	51-8015	25
51-7644	28	51-7785	16	51-8021	58
51-7645	29	51-7786	16	51-8022	58
51-7646	44	51-7787	16	51-8023	58
51-7647	67	51-7788	16	51-8026	30
51-7650	19	51-7789	16		30.01
51-7654	16	51-7794	20	51-8056	44
51-7655	44	51-7795	20	51-8058	31
51-7656	22	51-7796	20		68
51-7657	22	51-7800	12	51-8066	30
51-7658	22		13.01		30.01
51-7659	22		14	51-8067	25
51-7660	23	51-7829	67	51-8071	13
51-7661	23		67.01		148
51-7667	20	51-7831	69.02	51-8072	148
51-7668	20	51-7835	14		148.03
51-7672	16	51-7839	16	51-8073	148
51-7673	21	51-7842	25		148.03
51-7674	18	51-7848	54	51-8074	148
51-7677	58	51-7858	22		148.03
51-7678	58	51-7862	42	51-8075	148
51-7683	22	51-7867	44		148.03
51-7686	22	51-7868	44	51-8076	148
51-7689	31	51-7869	44		148.03
51-7691	42	51-7883	15	51-8077	148
51-7696	43	51-7886	29		148.03
51-7697	43	51-7895	46	51-8078	148

PART NUMBER INDEX

Part.No	Page	Part.No	Page	Part.No	Page
	211. 02		73		303
8T-0671	204		75		305
	205		77		307
	206		77. 02		308
8T-1158	385		77. 04		309
8T-1159	224		77. 06		309. 01
8T-1905	321		77. 08		309. 02
	323		77. 10		311
	325		77. 12		313
	331		91		321
	333		93. 02		323
	335		131		325
	337		135		327
	339		137		329
	341		153. 02		331
8T-2396	390		155		333
8T-2530	285		157		335
	285. 02		165		337
8T-2920	285		175. 02		339
	285. 02		179		339. 02
	361		185		339. 04
8T-3008	437. 01		198		341
8T-3338	247		211		351
	253		211. 02		355
8T-3647	537		235		357. 02
	545		237		359
8T-3957	349		239		361
	353		241		365
	357		243		367
	357. 04		251		369
8T-4121	30		278		377
	30. 01		279		380
	37		279. 02		380. 01
	37. 02		280		391
	41		280. 01		393
	41. 02		281		394
	46		282		397
	52		283		397. 01
	54		285. 02		455
	56		289		457
	57		290		459
	66		291		477
	68		295. 02		493
	71		301		494

PART NUMBER INDEX

Part.No	Page	Part.No	Page	Part.No	Page
	564.01		561	094-2080	91
093-0363	213		562		93.02
093-1290	295.02		562.01	094-3245	235
093-1291	281		562.02		239
	282		563	094-3247	65
	283		564		235
	289		564.01		239
	301		569.01	094-4628	18
	303		569.02		19
	305		570.01	094-4696	15
093-1292	280		570.02	094-7115	16
	280.01		571.01	094-7134	20
	289		571.02	094-7154	20
	295	093-2068	73	094-7516	20
	297		77.02	094-9525	15
	299		77.08	094-9581	68
093-1293	295	093-3093	429	094-9596	68
	297		429.01	094-9597	68
	299	093-3094	429	094-9672	29
093-1294	280.01		429.01	094-9725	67
093-1295	285	093-3328	429.03		67.01
	285.02	093-6089	377	094-9726	67
	289	093-7521	256		67.01
	301	093-7638	593	094-9950	147
	359	093-7680	584	094-9980	147
	361		585	095-0085	147
093-1296	345	093-7681	589	095-0410	147
093-1299	289	093-7682	575	095-0645	142
093-1300	289		576	095-0687	171
	295		589	095-0728	393
093-1342	569.01	093-7683	575		484
	569.02		576		494
	570.01		589	095-0735	93.04
	570.02	094-0876	390		394
	571.01		439.02		397
	571.02		441		397.01
093-1433	268	094-1875	247	095-0736	65
	269		249		497
	270		251		498
	271		253		499
	272		255		515.01
	558	094-1881	255	095-0742	95
	559	094-1882	247		97.02
	560		251		469

PART NUMBER INDEX

Part.No	Page	Part.No	Page	Part.No	Page
132-7701	390	135-2382	148	137-3625	259
132-7705	430		148.03		261
132-7711	390	135-2402	25	137-3626	259
132-7713	390	135-2403	42		261
133-2425	213	135-2405	30		262
	555		30.01	137-3628	259
	557	135-2407	46		261
	557.02	135-2409	43		262
133-2554	225	135-2419	18	137-5541	67
133-2717	213	135-2420	58		67.01
133-5813	321	135-2421	61	137-6114	228
	323	135-2422	61	137-6120	584
	339.04	135-2423	61	137-6121	585
133-7937	531	135-2424	61	137-6122	584
	543	135-2425	61		585
133-8016	467	135-2426	61	138-5184	120
134-3284	155	135-2427	61		122
	157	135-2428	61		128
134-6110	601	135-2429	61	139-0922	382.01
134-6146	597	135-2430	61		382.02
	599.04	135-2431	61	139-1762	285
134-6838	285	135-2432	61		285.02
	285.02	135-2433	61	139-1765	285
	361	135-4110	559		285.02
134-7178	569.01	135-4111	559	139-1773	282
	569.02	135-4114	559		283
	570.01	135-5701	48	139-3068	603.01
	570.02		50		608
	571.01	135-9000	333	139-7092	449
	571.02		341		452
134-7179	569.01	136-4055	93		454
	569.02		93.04	139-7099	455
	570.01	137-2255	177		459
	570.02		191		472
	571.01		202	139-7100	468
	571.02	137-2270	508		470
134-7258	595	137-2813	11	139-7101	455
	599.02		196		457
135-2363	147	137-2853	196		476
135-2364	147	137-2854	196	139-7119	483
135-2365	147	137-3623	259	139-7126	467
135-2366	147		261	139-7127	467
135-2369	145	137-3624	259	140-2187	566
135-2370	145		261	140-6836	566.01

PART NUMBER INDEX

Part.No	Page	Part.No	Page	Part.No	Page
	541	170-9836	268	171-0035	427
170-9712	536		273	171-0036	427
170-9715	539	170-9837	269	171-0037	427
	544		274	171-0087	439.02
170-9722	477	170-9840	275		441
	479	170-9842	273	171-0123	448
	480	170-9843	274	171-0124	448
	481		276	171-0126	448
170-9723	461		277	171-0127	448
	463	170-9856	275	171-0128	448
	465	170-9858	273	171-0183	443
	488	170-9859	274	171-0184	443
170-9724	461		276	171-0185	443
	463		277	171-0188	333
	465	170-9893	374		341
170-9800	267		378		444
	552	170-9937	273	171-0198	444
	553	170-9938	275	171-2208	91
	553.01	170-9940	275		93.02
170-9803	266	170-9941	275	171-2590	71
	270	170-9942	276	171-3369	35
170-9804	267	170-9943	277		35.02
	271	170-9945	276	171-7323	461
170-9805	267		277		463
	272	170-9946	276		465
170-9808	270		277	171-7325	461
	275	170-9999	274		463
170-9809	271	171-0002	367		465
	276		436	171-7336	449
170-9810	272	171-0006	398		450
	277		399		451
170-9826	235		433	171-7339	487.01
	239	171-0016	398	171-7344	510
	242		399		552
170-9831	265		402		553
	550		404		553.01
170-9832	265		406	171-7345	450
	550		408	171-7346	450
170-9833	266		410		452
	550	171-0019	431		456
170-9834	265	171-0020	431	171-7352	520.01
	268	171-0030	426	171-7372	391
170-9835	266		427		552
	269	171-0034	427		553

PART NUMBER INDEX

Part.No	Page	Part.No	Page	Part.No	Page
	92	193-9457	209	194-8280	169
193-3531	91	193-9696	65	194-8281	169
193-3533	78	193-9712	197	194-8282	169
	79	193-9766	203	194-8283	169
193-3537	137	193-9776	78	194-8284	169
	140		198	194-8285	169
193-3538	137		606	194-8286	169
	141	193-9793	198	194-8288	169
193-3550	165	194-0097	315	194-8289	169
	319.02	194-0149	337	194-8290	169
193-4991	589	194-0183	369	194-8291	169
193-6489	301	194-0185	369	194-8292	169
193-6490	280.01	194-0191	369	194-8295	169
	431.01	194-0192	343.02	194-8299	171
193-6491	280.01		431.01	194-8394	169
193-6492	280.01	194-0194	45	194-8399	379
193-6494	280.01		368	194-8400	379
193-6496	280.01	194-0201	367	194-8401	379
193-6547	303	194-0202	367	194-8765	192
193-6548	303	194-0317	311	194-8937	600
	308	194-0318	323	194-8941	11
193-6549	303	194-0319	323		605
	308	194-0320	343	194-8942	605
	309.01	194-0321	323	194-8943	605
193-6565	301	194-0322	323	194-8945	11
193-9350	194	194-0323	323	194-8947	551.02
193-9351	194	194-0324	323	194-8960	551.01
193-9352	194	194-0325	325	194-8988	551.01
193-9353	194	194-0328	325	194-9041	313
193-9354	194	194-0333	339.02	195-5360	551.02
193-9355	194	194-0381	347		570
193-9356	194		351	195-5361	570.01
193-9368	191		355		570.02
193-9379	194		357.02		571.01
193-9387	179		357.06		571.02
193-9431	187	194-0383	351	195-5408	551.01
193-9449	186		355		559
193-9450	186		357.02	195-5409	559
193-9454	45	194-0387	359	195-5411	551.01
	186	194-0391	285.02		571
193-9455	11		359	195-8834	71
	206		361	195-8943	71
193-9456	206	194-0392	359	195-8945	144
	209	194-8257	287	195-8946	143

CLICK HERE TO **DOWNLOAD** THE COMPLETE MANUAL

- Thank you very much for reading the preview of the manual.
- You can download the complete manual from: www.heydownloads.com by clicking the link below



- Please note: If there is no response to CLICKING the link, please download this PDF first and then click on it.

CLICK HERE TO **DOWNLOAD** THE COMPLETE MANUAL