

PART MANUAL

Manual Part Number 304943-000
ELECTRIC WALKIE ADJUSTABLE STRADDLE STACKER

WSX-20/25

Effective Serial Number 272581AA000

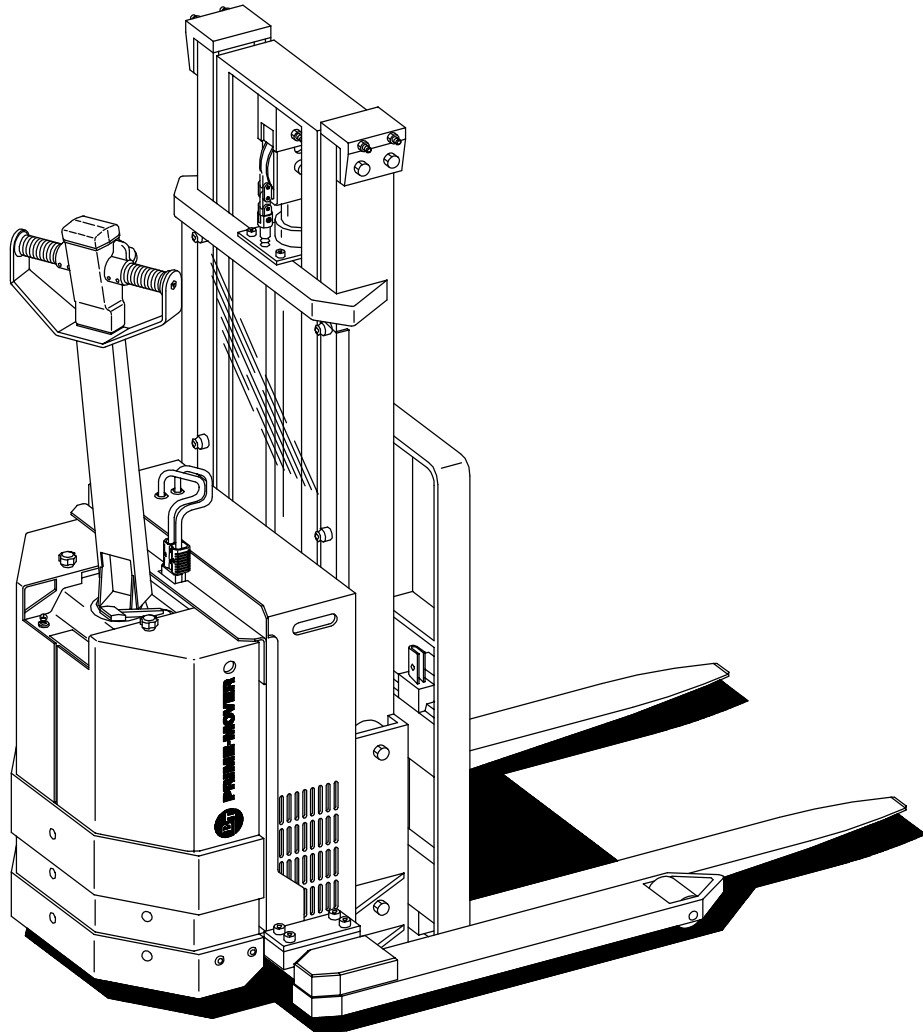

⚠ WARNING Read and observe all warnings on this unit before operating it.

⚠ WARNING **DO NOT** operate this equipment unless all factory installed guards and shields are properly secured in place.

CLICK HERE TO **DOWNLOAD** THE COMPLETE MANUAL

- Thank you very much for reading the preview of the manual.
- You can download the complete manual from: www.heydownloads.com by clicking the link below



- Please note: If there is no response to CLICKING the link, please download this PDF first and then click on it.

CLICK HERE TO **DOWNLOAD** THE COMPLETE MANUAL

0400-008 Frame / Chassis Component

IITEM			# FOR	
#	PART #	NAME	ASSY.	UNITS
11	134501	Guard, dust	1	
16	22420	Guard	As Req'd.	
17	28192	Clamp	1	
18	134334	Conduit entry (Grommet)	2	

0850-003 Decals, Warnings

IITEM			# FOR	UNITS
#	PART #	NAME	ASSY.	
11	136246	Decal, lifting hooks	2	
12	49990-00	Decal, WARNING	1	
13	121787-002	Sign	1	
14	121786-002	Sign	1	
15	302035-000	Decal, WARNING	1	
16	148226	Decal, lower	1	
17	72082	Sign	1	
18	302066-004	Decal, BT PRIME-MOVER logo	2	
19	304567-000	Decal, NO RIDING	1	
20	49975-00	Decal, WARNING	2	
*	52-00254-00	Paint, ORANGE	As Req'd.	
*	52-00257-00	Spray, ORANGE	As Req'd.	
*	52-00267-00	Paint, GRAPHITE GREEN	As Req'd.	
*	52-00269-00	Spray, GRAPHITE GREEN	As Req'd.	
*	49529-00	Cable, OPERATOR'S MANUAL	1	
*	49804-00	Sleeve, OPERATOR'S MANUAL	1	
*	304942-000	Manual, OPERATOR'S	1	
*	304943-000	Manual, PARTS	1	
*	304944-000	Manual, SERVICE	1	

3550-016 Fork / Support arm wheels (Load Wheel)

IITEM			# FOR	
#	PART #	NAME	ASSY.	UNITS
01	146382	Wheel Assembly, Vulkollan load	2	
02	148234	Wheel, Vulkollan	2	
11	20023	Bearing, ball	4	
12	20905	Seal	4	

5230-002 Battery Discharge Indicator/Hourmeter

IITEM			# FOR	
#	PART #	NAME	ASSY.	UNITS
01	301445-001	Battery Discharge Indicator/Hourmeter	1	

0000-000 Battery Discharge Indicator

IITEM			# FOR	
#	PART #	NAME	ASSY.	UNITS
01	23228-01	Battery Discharge Indicator	1	

5290-001 Hourmeter

IITEM			# FOR	
#	PART #	NAME	ASSY.	UNITS
01	302201-000	Hourmeter	1	

5430-012 Motor cable, resistor

ITEM			# FOR	
#	PART #	NAME	ASSY.	UNITS
01	29228	Fuse, 100AMP	1	
05	29223	Fuse, 160AMP	1	
11	148195	Cable	1	
12	148194	Cable	1	
13	139216	Cable(4)	1	
14	139217	Cable(5)	1	
15	139174	Cable(A2)	1	
16	139173	Cable(A1)	1	
17	136749	Cable	1	
18	146033	Cable	1	
19	136765	Cable	1	
20	147215	Cable	1	
21	146038	Cable	1	
22	146037	Cable	1	
23	136746	Cable	1	
24	65183	Insulator	4	
25	20348	Washer	4	
26	21393	Washer	4	
27	20045	Nut	4	
28	27500	Screw	4	

5710-003 PCBs logic card / box

IITEM			# FOR	UNITS
#	PART #	NAME	ASSY.	
01	136833-002	Logic box	1	
11	27500	Screw	2	

6120-034 Hoses and pipes, connection, fixation (Duplex HiLo)

ITEM			# FOR	
#	PART #	NAME	ASSY.	UNITS
11	146211-001	Hose, 106 inch (2700 mm)	1	71/104
11	146211-002	Hose, 131 inch (3300 mm)	1	83/128
11	146211-003	Hose, 146 inch (3700 mm)	1	91/144
12	28266	Connection	1	
13	28064	Connection	2	
14	24647	Clamp	1	
15	28858	Screw	1	

7310-019 Lift cylinders (Duplex HiLo)

ITEM			# FOR	
#	PART #	NAME	ASSY.	UNITS
01	149792-002	Lift cylinder assembly	1	71/104
01	149792-003	Lift cylinder assembly	1	83/128
01	149792-004	Lift cylinder assembly	1	91/144
02	149834	Set, packing (Kit)	1	
11	25299	Bleeder	1	
12	25150	Valve	1	

CLICK HERE TO **DOWNLOAD** THE COMPLETE MANUAL

- Thank you very much for reading the preview of the manual.
- You can download the complete manual from: www.heydownloads.com by clicking the link below



- Please note: If there is no response to CLICKING the link, please download this PDF first and then click on it.

CLICK HERE TO **DOWNLOAD** THE COMPLETE MANUAL