

# PARTS MANUAL

Manual Number 9108

Manual Part Number 301468-000

PMX-2 ELECTRIC LOW LIFT PALLET TRUCK

PMX-2

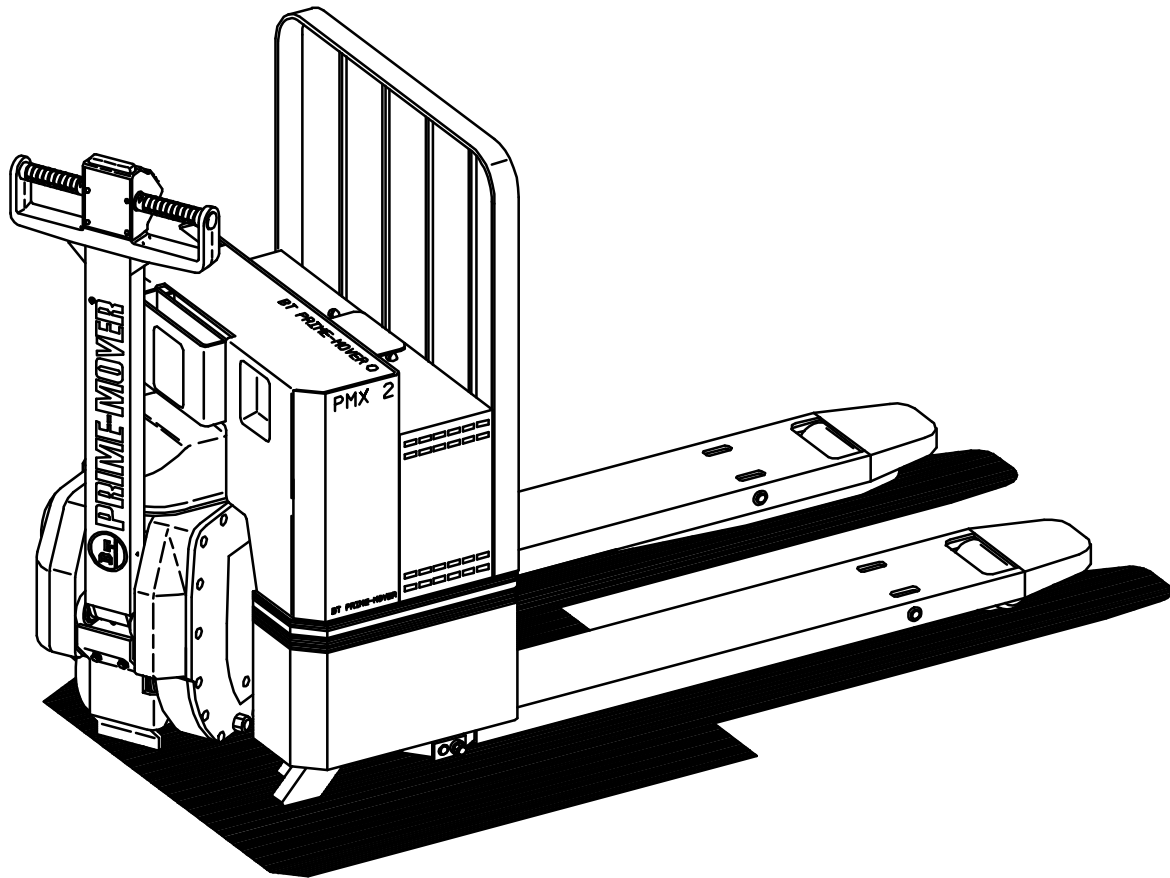

**⚠ WARNING**

Read and observe all warnings on this unit before operating it.

**⚠ WARNING**

**DO NOT** operate this equipment unless all factory installed guards and shields are properly secured in place.

CLICK HERE TO **DOWNLOAD** THE COMPLETE MANUAL

- Thank you very much for reading the preview of the manual.
- You can download the complete manual from: [www.heydownloads.com](http://www.heydownloads.com) by clicking the link below



- Please note: If there is no response to CLICKING the link, please download this PDF first and then click on it.

CLICK HERE TO **DOWNLOAD** THE COMPLETE MANUAL

FIG #	ITEM #	PART #	NAME	# FOR ASSY.	UNIT
1.1	1	23234-00	Nut, locking	1	
1.1	2	49972-08	Ring, nilos	1	
1.1	3	11205-12	Bearing	1	
1.1	4	-----	Frame assembly (See Fig.# 4.2)	1	
1.1	5	-----	Transmission assembly (See Fig.# 1.4)	1	
1.1	6	11205-23	Bearing	1	
1.1	7	49972-07	Ring, nilos	1	
1.1	8	23080-00	Bumper	1	
1.1	9	23223-02	Handle assembly, Twist grip (See Fig.# 1.2)	1	
1.1	9	23385-00	Handle assembly, Thumb control (See Fig.# 1.3)	1	

FIG #	ITEM #	PART #	NAME	# FOR ASSY.	UNIT
2.3	1	300291-000	Harness assembly (MAIN FRAME)	1	
2.3	2	20208-00	Switch, brake interlock	2	
2.3	*	14986-03	Nut, twin	2	
2.3	*	11880-08	Screw, machine	4	
2.3	3	20163-87	Wire assembly (HORN ONLY)	1	
2.3	3	23219-00	Wire assembly (HORN AND	1	
2.3	4	23359-00	HOURMETER)	1	12 VOLT
			Pump & motor assembly, 12 V hydraulic		
2.3	4	23360-00	(See Fig.# 3.5)	1	24 VOLT
			Pump & motor assembly, 24 V hydraulic		
2.3	5	49815-00	(See Fig.# 3.5)	1	
2.3	6	20151-00	Hourmeter	1	
2.3	7	23228-00	Switch, key	1	12 VOLT
2.3	7	23228-01	Indicator, battery discharge (BDI) 12V	1	24 VOLT
2.3	8	25275-07	Indicator, battery discharge (BDI) 24V	1	
2.3	9	14928-00	Fuse, 10 AMP	1	
2.3	10	23314-00	Holder, fuse	1	12 VOLT
2.3	10	23314-01	Control panel assembly (See Fig.# 2.5)	1	24 VOLT
2.3	11	20163-86	Control panel assembly (See Fig.# 2.5)	2	
2.3	12	14986-03	Wire assembly	4	
2.3	13	11880-08	Nut, twin	1	
2.3	14	25427-00	Screw, machine	1	12 VOLT
2.3	14	25427-01	Horn, 12 volt	1	24 VOLT
2.3	15	11016-02	Horn, 24 volt	1	
2.3	16	49751-04	Washer, flat	1	
2.3	17	23081-00	Nut	1	
2.3	18	23040-00	Harness, head wiring	3	
2.3	19	49506-00	Switch	1	12 VOLT
2.3	19	49506-01	Heater, 12 volt (cold storage)	1	24 VOLT
2.3	20	49607-00	Heater, 24 volt (cold storage)	1	
2.3	21	23040-00	Plug, diode	1	
2.3	22	23369-00	Switch, reverser	1	
2.3	23	23268-00	Switch, master	1	12 VOLT
2.3	23	23268-01	Indicator, BDI/hourmeter (OPTIONAL)	1	24 VOLT
2.3	24	25332-00	Indicator, BDI/hourmeter (OPTIONAL)	As Req'd	
			Tie, wire		

SB-175 \* 49855-33 \* 12 VOLT \* YELLOW

FIG	ITEM				# FOR	
#	#	PART #	NAME		ASSY.	UNIT
2.8	1	49855-33	Connector assembly SB-175 YELLOW		1	
2.8	2	49854-03	Connector, YELLOW housing		1	
2.8	3	49852-01	Connector, tip		2	
2.8	4	49853-02	Bushing		2	
2.8	5	49856-88	Cable, 29.50" NEGATIVE		1	
2.8	6	49856-87	Cable, 23.75" POSITIVE		1	

SB-175 \* 49855-34 \* 24 VOLT \* RED

FIG	ITEM				# FOR	
#	#	PART #	NAME		ASSY.	UNIT
2.8	1	49855-34	Connector assembly SB-175 RED		1	
2.8	2	49854-04	Connector, RED housing		1	
2.8	3	49852-01	Connector, tip		2	
2.8	4	49853-02	Bushing		2	
2.8	5	49856-88	Cable, 29.50" NEGATIVE		1	
2.8	6	49856-87	Cable, 23.75" POSITIVE		1	

SB-175 \* 49855-17 \* 12 VOLT \* GRAY

FIG	ITEM				# FOR	
#	#	PART #	NAME		ASSY.	UNIT
2.8	1	49855-17	Connector assembly SB-175 GRAY		1	
2.8	2	49854-01	Connector, GRAY housing		1	
2.8	3	49852-01	Connector, tip		2	
2.8	4	49853-02	Bushing		2	
2.8	5	49856-88	Cable, 29.50" NEGATIVE		1	
2.8	6	49856-87	Cable, 23.75" POSITIVE		1	

SB-175 \* 49855-17 \* 24 VOLT \* GRAY

FIG	ITEM				# FOR	
#	#	PART #	NAME		ASSY.	UNIT
2.8	1	49855-17	Connector assembly SB-175 GRAY		1	
2.8	2	49854-01	Connector, GRAY housing		1	
2.8	3	49852-01	Connector, tip		2	
2.8	4	49853-02	Bushing		2	
2.8	5	49856-88	Cable, 29.50" NEGATIVE		1	
2.8	6	49856-87	Cable, 23.75" POSITIVE		1	

0 136 350 011 \* 300120-000 \* 12 VOLT \* BOSCH

FIG #	ITEM #	PART #	NAME	# FOR ASSY.	UNIT
2.13	1	300124-001	Ring, retainer	1	
2.13	2	300124-002	Bearing	2	
2.13	3	300124-003	Armature	1	
2.13	4	300124-004	Spring washer	1	
2.13	5	300124-005	Stud, terminal	1	
2.13	6	300124-006	Screw, flat head	4	
2.13	7	300124-007	Screw, fillister head	4	
2.13	8	300120-001	Coil, field	1	
2.13	9	300124-009	Brush holder	1	
2.13	10	300124-010	Ring, retainer	1	
2.13	11	300124-011	Shield, commutator end	1	
2.13	12	300124-012	Screw, fillister head	4	
2.13	13	300124-013	Cap, protective	1	
2.13	14	300124-014	Screw, fillister head	2	
2.13	15	300124-015	Washer, flat	2	
2.13	16	300124-016	Pin, groved	1	
2.13	17	300124-017	Brush set	1	
2.13	18	300124-018	Lockwasher	4	
2.13	19	300124-019	Spring, spirol	4	

0 136 350 012 \* 300124-000 \* 24 VOLT \* BOSCH

FIG #	ITEM #	PART #	NAME	# FOR ASSY.	UNIT
2.13	1	300124-001	Ring, retainer	1	
2.13	2	300124-002	Bearing	2	
2.13	3	300124-003	Armature	1	
2.13	4	300124-004	Spring washer	1	
2.13	5	300124-005	Stud, terminal	1	
2.13	6	300124-006	Screw, flat head	4	
2.13	7	300124-007	Screw, fillister head	4	
2.13	8	300124-008	Coil, field	1	
2.13	9	300124-009	Brush holder	1	
2.13	10	300124-010	Ring, retainer	1	
2.13	11	300124-011	Shield, commutator end	1	
2.13	12	300124-012	Screw, fillister head	4	
2.13	13	300124-013	Cap, protective	1	
2.13	14	300124-014	Screw, fillister head	2	
2.13	15	300124-015	Washer, flat	2	
2.13	16	300124-016	Pin, groved	1	
2.13	17	300124-017	Brush set	1	
2.13	18	300124-018	Lockwasher	4	
2.13	19	300124-019	Spring, spirol	4	

FIG #	ITEM #	PART #	NAME	# FOR ASSY.	UNIT
4.1	1	23129-00	Shield	1	
4.1	2	23167-00	Stud	2	
4.1	3	23168-00	Grommet	2	
4.1	4	49696-00	Screw	2	
4.1	5	23292-00	Bracket	1	
4.1	6	23043-00	Shield, transmission	1	
4.1	7	11016-05	Washer, flat	2	
4.1	8	11854-04	Screw, cap	2	
4.1	9	11009-05	Lockwasher	2	
4.1	10	49509-00	Nut, clip	4	
4.1	11	23202-00	Bracket	2	
4.1	12	49922-01	Screw, machine	4	
4.1	13	23295-00	Decal	1	
4.1	14	23169-00	Receptacle	2	

FIG #	ITEM #	PART #	NAME	# FOR ASSY.	UNIT
5.4	1	49530-00	Nut, tee	8	
5.4	2	23200-00	Block, battery	6	
5.4	3	23199-00	Bracket, left	1	
5.4	3	23199-01	Bracket, right	1	
5.4	4	11852-17	Screw, socket head	4	
5.4	5	11852-22	Screw, socket head	4	
5.4	6	11016-04	Washer, flat	2	
5.4	7	11009-04	Lockwasher	2	
5.4	8	11045-02	Screw, cap	2	

# PARTS MANUAL

Manual Number 9206

Manual Part Number 301468-001

PMX-2 ELECTRIC LOW LIFT PALLET TRUCK

PMX-2

Effective Serial Number 223921

---

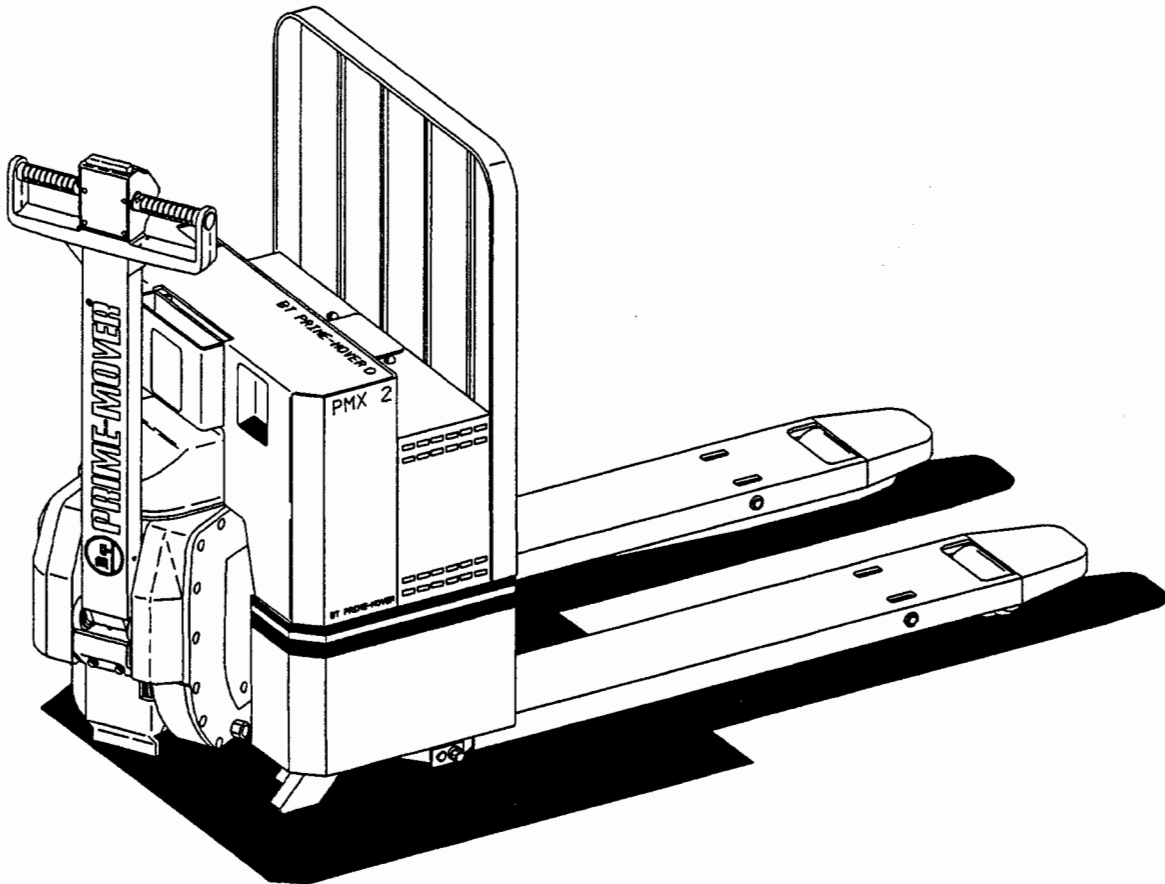

**⚠ WARNING** Read and observe all warnings on this unit before operating it.

**⚠ WARNING** DO NOT operate this equipment unless all factory installed guards and shields are properly secured in place.

Return

JUNE 1992

**BT** PRIME-MOVER

FIG #	ITEM #	PART #	NAME	# FOR ASSY.	UNIT
1.1	1	23221-00	Guard, wiring	1	
1.1	2	23234-00	Nut, locking	1	
1.1	3	49972-08	Ring, nilos	1	
1.1	4	11205-12	Bearing	1	
1.1	5	-----	Frame assembly (See Fig.# 4.2)	1	
1.1	6	-----	Transmission assembly (See Fig.# 1.4)	1	
1.1	7	11205-23	Bearing	1	
1.1	8	49972-07	Ring, nilos	1	
1.1	9	23080-00	Bumper	1	
1.1	10	23223-02	Handle assembly, Twist grip (See Fig.# 1.2)	1	
1.1	10	23385-00	Handle assembly, Thumb control (See Fig.# 1.3)	1	
1.1	11	11160-11	Fitting, grease	1	

FIG #	ITEM #	PART #	NAME	# FOR ASSY.	UNIT
2.3	1	23400-00	Harness, main wiring	1	
2.3	2	11880-08	Screw, machine	2	
2.3	3	20208-00	Switch, brake interlock	1	
2.3	4	14986-03	Nut, twin	1	
2.3	5	49815-00	Hourmeter	1	
2.3	6	20163-87	Wire assembly	1	
2.3	7	20163-91	Wire assembly	1	
2.3	8	20163-90	Wire assembly	1	
2.3	9	20151-00	Switch, key	1	
2.3	10	23228-00	Indicator, battery discharge (BDI) 12V	1	12 VOLT
2.3	10	23228-01	Indicator, battery discharge (BDI) 24V	1	24 VOLT
2.3	11	20163-88	Wire assembly	1	
2.3	12	14928-00	Holder, fuse (part of wiring harness)	1	
2.3	13	25275-07	Fuse, 10 AMP	1	
2.3	14	23425-00	Pump & motor assembly, 12V hydraulic (See Fig.# 3.5)	1	12 VOLT
2.3	14	23424-00	Pump & motor assembly, 24V hydraulic (See Fig.# 3.5)	1	24 VOLT
2.3	15	23314-00	Control panel assembly, 12 Volt (See Fig.# 2.5)	1	12 VOLT
2.3	15	23314-02	Control panel assembly, 24 Volt (See Fig.# 2.5)	1	24 VOLT
2.3	16	23401-00	Harness, frame wiring	1	
2.3	17	49751-04	Nut	1	
2.3	18	11016-02	Washer, flat	1	
2.3	19	23309-00	Horn, 12 volt	1	12 VOLT
2.3	19	23309-01	Horn, 24 volt	1	24 VOLT
2.3	20	25332-00	Tie, wire	As Req'd.	
2.3	21	14986-03	Nut, twin	1	
2.3	22	20208-00	Switch, lift limit	1	
2.3	23	11880-08	Screw, machine	2	
2.3	24	301445-000	Indicator, BDI/Hourmeter (OPTIONAL)	1	12 VOLT
2.3	24	301445-001	Indicator, BDI/Hourmeter (OPTIONAL)	1	24 VOLT
2.3	25	11261-02	Nut	2	
2.3	26	11009-02	Lockwasher	2	
2.3	27	49831-00	Thermostat	1	
2.3	28	11016-23	Washer, flat	2	
2.3	29	11881-04	Screw, machine	2	
2.3	30	23040-00	Switch	3	
2.3	31	49506-00	Heater, 12 volt (cold storage)	1	12 VOLT
2.3	31	49506-01	Heater, 24 volt (cold storage)	1	24 VOLT
2.3	32	49607-00	Plug, diode	1	
2.3	33	23081-00	Harness, head wiring	1	
2.3	34	23040-00	Switch, reverser	1	
2.3	35	23369-00	Switch, master	1	

SB-175 \* 49855-33 \* 12 VOLT \* YELLOW

FIG #	ITEM #	PART #	NAME	# FOR ASSY.	UNIT
2.8	1	49855-33	Connector assembly SB-175 YELLOW	1	
2.8	2	49854-03	Connector, YELLOW housing	1	
2.8	3	49852-01	Connector, tip	2	
2.8	4	49853-02	Bushing	2	
2.8	5	49856-88	Cable, 29.50" NEGATIVE	1	
2.8	6	49856-87	Cable, 23.75" POSITIVE	1	

SB-175 \* 49855-34 \* 24 VOLT \* RED

FIG #	ITEM #	PART #	NAME	# FOR ASSY.	UNIT
2.8	1	49855-34	Connector assembly SB-175 RED	1	
2.8	2	49854-04	Connector, RED housing	1	
2.8	3	49852-01	Connector, tip	2	
2.8	4	49853-02	Bushing	2	
2.8	5	49856-88	Cable, 29.50" NEGATIVE	1	
2.8	6	49856-87	Cable, 23.75" POSITIVE	1	

SB-175 \* 49855-17 \* 12 VOLT \* GRAY

FIG #	ITEM #	PART #	NAME	# FOR ASSY.	UNIT
2.8	1	49855-17	Connector assembly SB-175 GRAY	1	
2.8	2	49854-01	Connector, GRAY housing	1	
2.8	3	49852-01	Connector, tip	2	
2.8	4	49853-02	Bushing	2	
2.8	5	49856-88	Cable, 29.50" NEGATIVE	1	
2.8	6	49856-87	Cable, 23.75" POSITIVE	1	

SB-175 \* 49855-17 \* 24 VOLT \* GRAY

FIG #	ITEM #	PART #	NAME	# FOR ASSY.	UNIT
2.8	1	49855-17	Connector assembly SB-175 GRAY	1	
2.8	2	49854-01	Connector, GRAY housing	1	
2.8	3	49852-01	Connector, tip	2	
2.8	4	49853-02	Bushing	2	
2.8	5	49856-88	Cable, 29.50" NEGATIVE	1	
2.8	6	49856-87	Cable, 23.75" POSITIVE	1	

FIG #	ITEM #	PART #	NAME	# FOR ASSY.	UNIT
3.3	1	23023-00	Cylinder assembly (See Fig.# 3.4)	1	
3.3	1	23023-01	Cylinder assembly (lube package & cold storage) (See Fig.# 3.4)	1	lube package & cold storage
3.3	2	49653-01	Fitting, 90°	1	
3.3	3	12391-05	O ring	1	
3.3	4	49604-01	O ring	1	
3.3	5	49517-00	Hose	1	
3.3	6	49656-01	Reducer	1	
3.3	7	49604-01	O ring	1	
3.3	8	12391-05	O ring	1	
3.3	9	23425-00	Hydraulic pump and motor assembly, 12 Volt (See Fig.# 3.5)	1	12 VOLT
3.3	9	23424-00	Hydraulic pump and motor assembly, 24 Volt (See Fig.# 3.5)	1	24 VOLT
3.3	10	11143-04	Screw, cap	2	
3.3	11	11009-06	Lockwasher	2	
3.3	12	11016-13	Washer, flat	2	

FIG #	ITEM #	12 VOLT	24 VOLT	NAME	# FOR ASSY. UNIT
5.1	1	23271-00	23271-00	Wrapper	1
5.1	2	27246-00	27246-00	Door	1
5.1	3	49922-01	49922-01	Screw, truss head	4
5.1	4	49751-06	49751-06	Nut, flange	2
5.1	5	49583-00	49583-00	Decal, warning	1
5.1	6	52-05009-00	52-05009-00	Edging, (3 feet)	As req'd
5.1	7	27233-02	27233-01	Charger, battery	1
5.1	*	204295	204294	Ampmeter	1
5.1	*	204296	204296	Capacitor	1
5.1	*	204297	204297	Breaker, 50 AMP circuit	1
5.1	*	204298	204298	Diode	1
5.1	*	204299	204299	Rectifier	1
5.1	*	204300	204300	Timer	1
5.1	8	-----	-----	Cable assembly (See Fig.# 5.2)	1
5.1	9	49504-00	49532-00	Decal, instruction	1
5.1	10	11854-03	11854-03	Screw, cap	2
5.1	11	11854-04	11854-04	Screw, cap	1
5.1	12	11016-02	11016-02	Washer, flat	1
5.1	13	11009-05	11009-05	Lockwasher	1
5.1	14	27234-00	27234-00	Battery	4
5.1	15	23274-00	23274-00	Case, battery	1
5.1	16	14851-02	14851-02	Nut, clip	2
5.1	17	49751-04	49751-04	Nut, flange	2
5.1	18	23281-00	23281-00	Tray, battery	1
5.1	19	23281-01	23281-01	Tray, battery	1
5.1	20	41520-00	41520-00	Mat, insulator	2
5.1	21	49443-00	49443-00	Decal, warning	1

# MODEL PMX 2 ELECTRIC LOW LIFT TRUCK

## NUMERICAL INDEX

This Numerical Index gives part numbers and figure numbers on which they are listed. Item numbers have also been listed for easier location of part numbers.

<u>PART #</u>	<u>FIG. #</u>	<u>ITEM #</u>	<u>PART #</u>	<u>FIG. #</u>	<u>ITEM #</u>
11009-01	2.5	29	11135-02	1.4	6
11009-01	2.5	29	11143-03	2.4	8
11009-02	2.3	26	11143-03	1.4	46
11009-03	2.5	11	11143-04	3.3	10
11009-04	2.5	7	11143-04	4.2	3
11009-04	5.4	7	11160-09	4.2	17
11009-05	4.1	9	11160-11	1.1	11
11009-05	5.1	12	11160-11	4.2	34
11009-06	3.3	11	11160-14	4.2	35
11009-06	1.4	45	11170-01	2.5	30
11009-06	4.2	4	11170-04	2.5	3
11015-42	1.4	21	11170-04	2.4	3
11016-01	2.5	6	11170-08	4.2	40
11016-02	2.3	18	11176-01	1.2	11
11016-02	3.5	12	11176-01	1.3	11
11016-02	5.2	7	11176-04	2.5	14
11016-02	5.2	7	11176-09	1.3	61
11016-02	5.1	11	11176-09	1.2	59
11016-04	5.4	6	11176-16	2.5	16
11016-04	4.2	39	11176-18	2.5	15
11016-05	4.1	7	11176-19	2.5	18
11016-12	2.5	22	11205-05	1.4	33
11016-13	3.3	12	11205-12	1.1	4
11016-13	4.2	8	11205-23	1.1	7
11016-16	4.2	28	11261-02	2.3	25
11016-21	2.5	28	11261-04	1.4	4
11016-23	2.3	28	11261-05	5.2	6
11016-25	2.5	12	11261-05	5.2	6
11025-16	1.3	22	11695-01	1.4	48
11030-06	1.4	30	11695-05	1.4	51
11039-22	1.4	39	11806-05	2.5	39
11045-02	5.4	8	11806-06	1.3	35
11045-06	2.4	4	11806-06	1.2	32
11047-03	1.2	24	11813-07	5.2	5
11047-03	1.3	26	11813-07	5.2	9
11047-19	1.3	43	11813-11	5.2	4
11047-19	1.2	41	11813-11	5.2	10
11047-30	1.2	22	11837-10	4.2	36
11047-30	1.3	25	11844-02	1.4	10
11072-13	1.2	15	11852-17	5.4	4
11072-13	1.3	8	11852-22	5.4	5
11072-13	1.2	8	11852-52	1.3	24
11072-13	1.3	14	11854-02	2.5	37
11073-21	4.2	14	11854-03	5.1	9
11073-26	1.2	48	11854-04	1.4	47
11073-26	1.3	50	11854-04	4.1	8
11073-29	1.2	21	11854-04	5.1	10
11073-33	4.2	20	11854-06	2.5	31
11073-33	1.4	58	11854-06	2.5	21
11129-03	2.5	10	11857-03	4.2	13
11129-05	1.4	54	11859-04	1.4	27

CLICK HERE TO **DOWNLOAD** THE COMPLETE MANUAL

- Thank you very much for reading the preview of the manual.
- You can download the complete manual from: [www.heydownloads.com](http://www.heydownloads.com) by clicking the link below



- Please note: If there is no response to CLICKING the link, please download this PDF first and then click on it.

CLICK HERE TO **DOWNLOAD** THE COMPLETE MANUAL

# ALPHABETICAL INDEX

NAME	FIG.#	PAGE #
<b>M,N</b>		
Numerical index	*	99.1
<b>O,P</b>		
Parts list index	0.1	0.1
Power component assembly	2.4	2.5
Power connector assembly SB-175 (RED), 24 volt	2.8	2.13
Power connector assembly SB-175 (YELLOW), 12 volt	2.8	2.13
Power connector assembly SB-175 (GRAY), 12/24 volt	2.8	2.13
Pump motor assembly, 12 volt, ISKRA	2.11	2.19
Pump motor assembly, 24 volt, ISKRA	2.11	2.19
<b>Q,R,S</b>		
Shield assembly	4.1	4.1
Special tools and lubrications	10.1	10.1
<b>T</b>		
Thumb control handle assembly, RESISTOR	1.4	1.7
Thumb control handle assembly, TRANSISTOR	1.5	1.9
Transmission assembly	1.6	1.11
Transmission and handle installation	1.1	1.1
Twist grip control handle assembly, RESISTOR	1.2	1.3
Twist grip control handle assembly, TRANSISTOR	1.3	1.5
<b>U,V,W,X,Y,Z</b>		

FIG #	ITEM #	PART #	NAME	# FOR ASSY.	UNIT
1.3	10	23067-00	Plate, switch	1	
1.3	11	11176-01	Screw, truss head	4	
1.3	12	23214-00	Spring	6	
1.3	13	23033-00	Bushing, sleeve	2	
1.3	14	14900-00	Nut	5	
1.3	15	11072-13	Lockwasher	6	
1.3	16	23040-00	Switch	3	
1.3	17	49525-04	Screw, flat head	1	
1.3	18	49519-06	Screw, machine	1	
1.3	19	49519-04	Screw, machine	3	
1.3	20	23035-00	Grip, hand	2	
1.3	21	11073-29	Pin, roll	2	
1.3	22	11047-30	Screw, Allen head	2	
1.3	23	23034-00	Bushing	2	
1.3	24	11047-03	Screw, Allen head 2.25" long	1	
1.3	25	14892-03	Screw, flanged head cap	2	
1.3	26	20329-01	Ring, grip	2	
1.3	27	14851-02	Nut, clip	1	
1.3	28	15677-01	Clamp	1	
1.3	29	49688-02	Screw, cap	1	
1.3	30	27298-00	Pin	1	
1.3	31	23244-00	Sheave	1	
1.3	32	11806-06	Nut, jam	1	
1.3	33	23242-00	Anchor, chain	1	
1.3	34	21542-10	Chain	1	
1.3	35	300661-001	Link, connector	1	
1.3	36	23026-00	Spring, return	1	
1.3	37	23414-01	Tube, plastic	1	
1.3	38	23078-00	Plate, anchor	1	
1.3	39	23430-00	Handle, lower	1	
1.3	40	14892-02	Screw, flange 1.00" long	2	
1.3	41	11047-19	Screw, Allen head 1.25 long	2	
1.3	42	23024-00	Guard, hand	1	
1.3	43	27303-00	Switch, transistor master	1	
1.3	44	27523-00	Bushing, flanged	1	
1.3	45	11936-04	Washer, shim	As Req'd.	
1.3	46	27541-00	Gear, miter	2	
1.3	47	23032-00	Shaft	1	
1.3	48	11073-26	Pin, roll	1	
1.3	49	23030-00	Washer, stop	1	
1.3	50	23061-00	Housing, head	1	
1.3	51	23044-02	Bar, lower	1	
1.3	52	23044-01	Bar, raise	1	
1.3	53	23044-00	Bar, horn	1	
1.3	54	49506-03	Heater, 24 VOLT (COLD STORAGE)	1	
1.3	55	23460-00	Potentiometer	1	
1.3	56	49607-00	Plug, diode	1	
1.3	57	27312-00	Harness, head wiring	1	
1.3	58	23459-00	Harness, main wiring	1	

FIG #	ITEM #	PART #	NAME	# FOR ASSY.	UNIT
2.3	1	23400-00	Harness, main wiring	1	
2.3	2	11880-08	Screw, machine	2	
2.3	3	20208-00	Switch, brake interlock	1	
2.3	4	14986-03	Nut, twin	1	
2.3	5	49815-00	Hourmeter	1	
2.3	6	20163-87	Wire assembly	1	
2.3	7	20163-91	Wire assembly	1	
2.3	8	20163-90	Wire assembly	1	
2.3	9	20151-00	Switch, key	1	
2.3	10	23228-00	Indicator, battery discharge (BDI) 12V	1	12 VOLT
2.3	10	23228-01	Indicator, battery discharge (BDI) 24V	1	24 VOLT
2.3	11	20163-88	Wire assembly	1	
2.3	12	14928-00	Holder, fuse (part of wiring harness)	1	
2.3	13	25275-07	Fuse, 10 AMP	1	
2.3	14	23425-00	Pump & motor assembly, 12V hydraulic (See Fig.# 3.5)	1	12 VOLT
2.3	14	23424-00	Pump & motor assembly, 24V hydraulic (See Fig.# 3.5)	1	24 VOLT
2.3	15	23314-00	Control panel assembly, 12 Volt (See Fig.# 2.5)	1	12 VOLT
2.3	15	23314-02	Control panel assembly, 24 Volt (See Fig.# 2.5)	1	24 VOLT
2.3	16	23401-00	Harness, frame wiring	1	
2.3	17	49751-04	Nut	1	
2.3	18	11016-02	Washer, flat	1	
2.3	19	23309-00	Horn, 12 volt	1	12 VOLT
2.3	19	23309-01	Horn, 24 volt	1	24 VOLT
2.3	20	25332-00	Tie, wire	As Req'd.	
2.3	21	14986-03	Nut, twin	1	
2.3	22	20208-00	Switch, lift limit	1	
2.3	23	11880-08	Screw, machine	2	
2.3	24	301445-000	Indicator, BDI/Hourmeter (OPTIONAL)	1	12 VOLT
2.3	24	301445-001	Indicator, BDI/Hourmeter (OPTIONAL)	1	24 VOLT
2.3	25	11261-02	Nut	2	
2.3	26	11009-02	Lockwasher	2	
2.3	27	49831-00	Thermostat	1	
2.3	28	11016-23	Washer, flat	2	
2.3	29	11881-04	Screw, machine	2	
2.3	30	23040-00	Switch	3	
2.3	31	49506-00	Heater, 12 volt (cold storage)	1	12 VOLT
2.3	31	49506-01	Heater, 24 volt (cold storage)	1	24 VOLT
2.3	32	49607-00	Plug, diode	1	
2.3	33	23081-00	Harness, head wiring	1	
2.3	34	23040-00	Switch, reverser	1	
2.3	35	23369-00	Switch, master	1	

FIGURE # 2.9 TRANSISTOR ELECTRICAL SCHEMATIC SYMBOLS

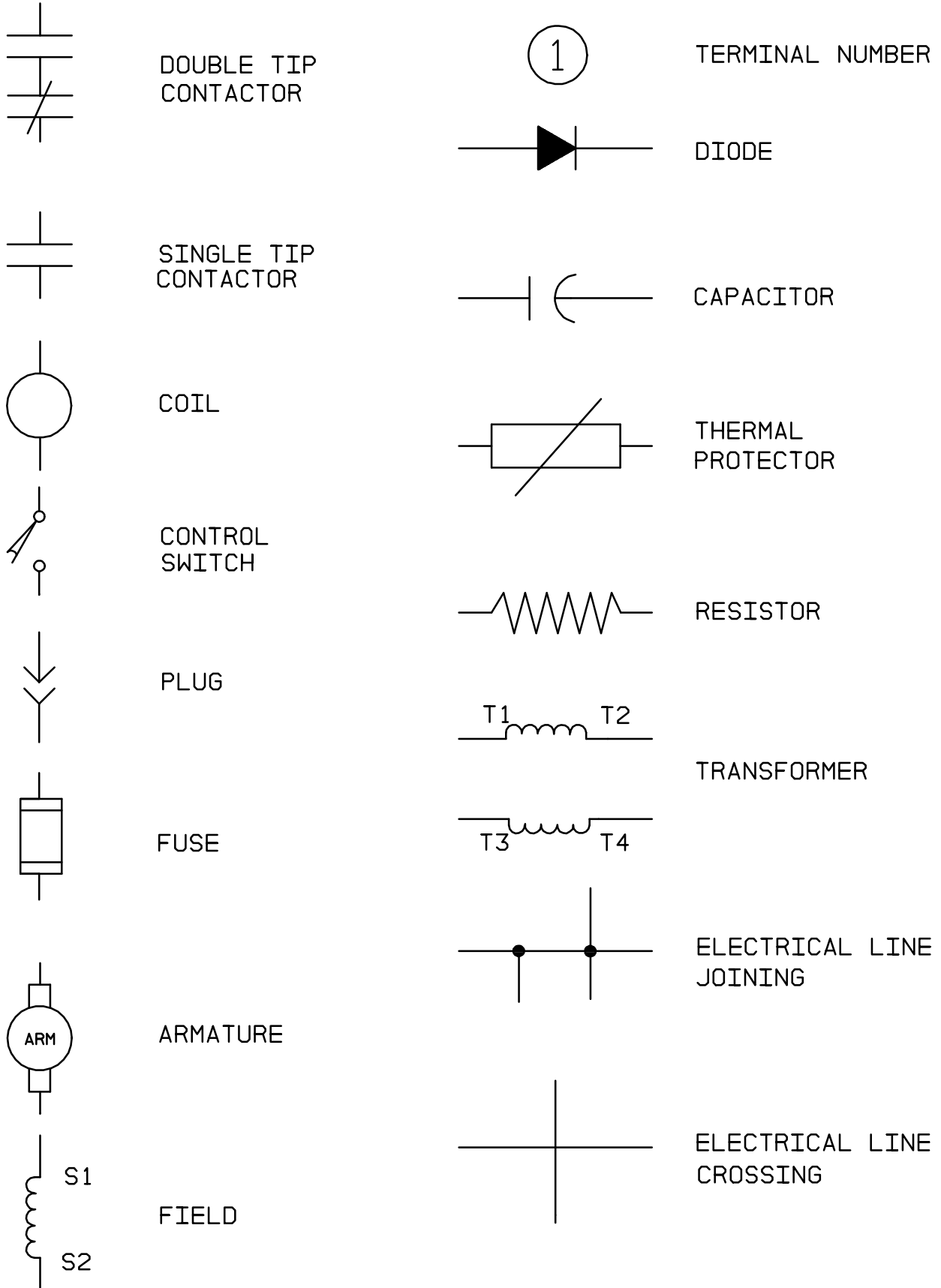

SB-175 \* 49855-33 \* 12 VOLT \* YELLOW

FIG	ITEM				# FOR	
#	#	PART #	NAME		ASSY.	UNIT
2.14	1	49855-33	Connector assembly SB-175 YELLOW		1	
2.14	2	49854-03	Connector, YELLOW housing		1	
2.14	3	49852-01	Connector, tip		2	
2.14	4	49853-02	Bushing		2	
2.14	5	49856-88	Cable, 29.50" NEGATIVE		1	
2.14	6	49856-87	Cable, 23.75" POSITIVE		1	

SB-175 \* 49855-34 \* 24 VOLT \* RED

FIG	ITEM				# FOR	
#	#	PART #	NAME		ASSY.	UNIT
2.14	1	49855-34	Connector assembly SB-175 RED		1	
2.14	2	49854-04	Connector, RED housing		1	
2.14	3	49852-01	Connector, tip		2	
2.14	4	49853-02	Bushing		2	
2.14	5	49856-88	Cable, 29.50" NEGATIVE		1	
2.14	6	49856-87	Cable, 23.75" POSITIVE		1	

SB-175 \* 49855-17 \* 12 VOLT \* GRAY

FIG	ITEM				# FOR	
#	#	PART #	NAME		ASSY.	UNIT
2.14	1	49855-17	Connector assembly SB-175 GRAY		1	
2.14	2	49854-01	Connector, GRAY housing		1	
2.14	3	49852-01	Connector, tip		2	
2.14	4	49853-02	Bushing		2	
2.14	5	49856-88	Cable, 29.50" NEGATIVE		1	
2.14	6	49856-87	Cable, 23.75" POSITIVE		1	

SB-175 \* 49855-17 \* 24 VOLT \* GRAY

FIG	ITEM				# FOR	
#	#	PART #	NAME		ASSY.	UNIT
2.14	1	49855-17	Connector assembly SB-175 GRAY		1	
2.14	2	49854-01	Connector, GRAY housing		1	
2.14	3	49852-01	Connector, tip		2	
2.14	4	49853-02	Bushing		2	
2.14	5	49856-88	Cable, 29.50" NEGATIVE		1	
2.14	6	49856-87	Cable, 23.75" POSITIVE		1	

FIG #	ITEM #	PART #	NAME	# FOR ASSY.	UNIT
3.3	1	23023-00	Cylinder assembly (See Fig.# 3.4)	1	
3.3	1	23023-01	Cylinder assembly (lube package & cold storage) (See Fig.# 3.4)	1	lube package & cold storage
3.3	2	49653-01	Fitting, 90°	1	
3.3	3	12391-05	O ring	1	
3.3	4	49604-01	O ring	1	
3.3	5	49517-00	Hose	1	
3.3	6	49656-01	Reducer	1	
3.3	7	49604-01	O ring	1	
3.3	8	12391-05	O ring	1	
3.3	9	23425-00	Hydraulic pump and motor assembly, 12 Volt (See Fig.# 3.5)	1	12 VOLT
3.3	9	23424-00	Hydraulic pump and motor assembly, 24 Volt (See Fig.# 3.5)	1	24 VOLT
3.3	10	11143-04	Screw, cap	2	
3.3	11	11009-06	Lockwasher	2	
3.3	12	11016-13	Washer, flat	2	

FIG #	ITEM #	12 VOLT	24 VOLT	NAME	# FOR ASSY. UNIT
5.1	1	23271-00	23271-00	Wrapper	1
5.1	2	27246-00	27246-00	Door	1
5.1	3	49922-01	49922-01	Screw, truss head	4
5.1	4	49751-06	49751-06	Nut, flange	2
5.1	5	49583-00	49583-00	Decal, warning	1
5.1	6	52-05009-00	52-05009-00	Edging, (3 feet)	As req'd
5.1	7	27233-02	27233-01	Charger, battery	1
5.1	*	204295	204294	Ampmeter	1
5.1	*	204296	204296	Capacitor	1
5.1	*	204297	204297	Breaker, 50 AMP circuit	1
5.1	*	204298	204298	Diode	1
5.1	*	204299	204299	Rectifier	1
5.1	*	204300	204300	Timer	1
5.1	8	-----	-----	Cable assembly (See Fig.# 5.2)	1
5.1	9	49504-00	49532-00	Decal, instruction	1
5.1	10	11854-03	11854-03	Screw, cap	2
5.1	11	11854-04	11854-04	Screw, cap	1
5.1	12	11016-02	11016-02	Washer, flat	1
5.1	13	11009-05	11009-05	Lockwasher	1
5.1	14	27234-00	27234-00	Battery	4
5.1	15	23274-00	23274-00	Case, battery	1
5.1	16	14851-02	14851-02	Nut, clip	2
5.1	17	49751-04	49751-04	Nut, flange	2
5.1	18	23281-00	23281-00	Tray, battery	1
5.1	19	23281-01	23281-01	Tray, battery	1
5.1	20	41520-00	41520-00	Mat, insulator	2
5.1	21	49443-00	49443-00	Decal, warning	1

# MODEL PMX-2 ELECTRIC LOW LIFT TRUCK

## NUMERICAL INDEX

<u>PART #</u>	<u>FIG. #</u>	<u>ITEM #</u>	<u>PART #</u>	<u>FIG.#</u>	<u>ITEM #</u>
20208-00	2.10	3	23026-00	1.4	39
20208-00	2.3	3	23026-00	1.5	39
20208-00	2.10	12	23026-00	1.2	36
20208-00	2.3	22	23030-00	1.4	51
202154	10.1	1	23030-00	1.2	49
202315	3.5	9	23030-00	1.3	49
202324	3.5	6	23030-00	1.5	51
202326	3.5	15	23032-00	1.3	47
202350	2.7	K	23032-00	1.2	47
202351	2.6	K	23033-00	1.3	13
202351	2.13	K	23033-00	1.2	13
202356	2.17	9	23034-00	1.2	23
202357	2.17	9	23034-00	1.3	23
202388	3.5	22	23035-00	1.2	20
202393	3.5	10	23035-00	1.3	20
202394	3.5	19	23036-00	1.3	4
20262-01	1.6	41	23036-00	1.4	4
20329-01	1.5	28	23036-00	1.5	4
20329-01	1.4	28	23036-00	1.2	4
20329-01	1.3	26	23037-00	1.2	7
20329-01	1.2	26	23037-00	1.5	7
204294	5.1	*	23037-00	1.3	7
204295	5.1	*	23037-00	1.4	7
204296	5.1	*	23040-00	1.3	16
204297	5.1	*	23040-00	2.10	24
204298	5.1	*	23040-00	1.4	15
204299	5.1	*	23040-00	1.5	15
204300	5.1	*	23040-00	2.10	27
21542-10	1.2	34	23040-00	1.3	3
21542-10	1.5	37	23040-00	1.5	3
21542-10	1.4	37	23040-00	1.2	3
21542-10	1.3	34	23040-00	2.3	33
22226-03	2.5	4	23040-00	1.2	16
22226-04	2.5	4	23040-00	2.3	30
23001-00	1.6	42	23040-00	1.4	3
23002-00	1.6	32	23041-00	4.2	11
23005-00	1.6	31	23043-00	4.1	6
23006-00	1.6	25	23044-00	1.3	53
23007-00	1.6	38	23044-00	1.5	55
23008-00	1.6	12	23044-00	1.4	55
23012-00	1.6	26	23044-00	1.2	53
23013-00	1.6	2	23044-01	1.2	52
23014-00	2.5	25	23044-01	1.3	52
23014-01	2.5	25	23044-01	1.4	54
23014-01	2.12	16	23044-01	1.5	54
23015-00	2.5	24	23044-02	1.3	51
23015-01	2.5	24	23044-02	1.4	53
23019-00	1.6	11	23044-02	1.5	53
23023-00	3.3	1	23044-02	1.2	51
23023-01	3.3	1	23045-00	3.4	1
23024-00	1.3	42	23045-01	3.4	1
23024-00	1.2	42	23049-00	1.6	3
23026-00	1.3	36	23050-00	1.6	7

# ALPHABETICAL INDEX

NAME	FIG.#	PAGE #
<b>M,N</b>		
Numerical index	*	99.1
<b>O,P</b>		
Parts list index	0.1	0.1
Power component assembly	2.4	2.5
Power connector assembly SB-175 (RED), 24 volt	2.8	2.13
Power connector assembly SB-175 (YELLOW), 12 volt	2.8	2.13
Power connector assembly SB-175 (GRAY), 12/24 volt	2.8	2.13
Pump motor assembly, 12 volt, ISKRA	2.11	2.19
Pump motor assembly, 24 volt, ISKRA	2.11	2.19
<b>Q,R,S</b>		
Shield assembly	4.1	4.1
Special tools and lubrications	10.1	10.1
<b>T</b>		
Thumb control handle assembly, RESISTOR	1.4	1.7
Thumb control handle assembly, TRANSISTOR	1.5	1.9
Transmission assembly	1.6	1.11
Transmission and handle installation	1.1	1.1
Twist grip control handle assembly, RESISTOR	1.2	1.3
Twist grip control handle assembly, TRANSISTOR	1.3	1.5
<b>U,V,W,X,Y,Z</b>		

FIG #	ITEM #	PART #	NAME	# FOR ASSY.	UNIT
1.3	10	23067-00	Plate, switch	1	
1.3	11	11176-01	Screw, truss head	4	
1.3	12	23214-00	Spring	6	
1.3	13	23033-00	Bushing, sleeve	2	
1.3	14	14900-00	Nut	5	
1.3	15	11072-13	Lockwasher	6	
1.3	16	23040-00	Switch	3	
1.3	17	49525-04	Screw, flat head	1	
1.3	18	49519-06	Screw, machine	1	
1.3	19	49519-04	Screw, machine	3	
1.3	20	23035-00	Grip, hand	2	
1.3	21	11073-29	Pin, roll	2	
1.3	22	11047-30	Screw, Allen head	2	
1.3	23	23034-00	Bushing	2	
1.3	24	11047-03	Screw, Allen head 2.25" long	1	
1.3	25	14892-03	Screw, flanged head cap	2	
1.3	26	20329-01	Ring, grip	2	
1.3	27	14851-02	Nut, clip	1	
1.3	28	15677-01	Clamp	1	
1.3	29	49688-02	Screw, cap	1	
1.3	30	27298-00	Pin	1	
1.3	31	23244-00	Sheave	1	
1.3	32	11806-06	Nut, jam	1	
1.3	33	23242-00	Anchor, chain	1	
1.3	34	21542-10	Chain	1	
1.3	35	300661-001	Link, connector	1	
1.3	36	23026-00	Spring, return	1	
1.3	37	23414-01	Tube, plastic	1	
1.3	38	23078-00	Plate, anchor	1	
1.3	39	23430-00	Handle, lower	1	
1.3	40	14892-02	Screw, flange 1.00" long	2	
1.3	41	11047-19	Screw, Allen head 1.25 long	2	
1.3	42	23024-00	Guard, hand	1	
1.3	43	27303-00	Switch, transistor master	1	
1.3	44	27523-00	Bushing, flanged	1	
1.3	45	11936-04	Washer, shim	As Req'd.	
1.3	46	27541-00	Gear, miter	2	
1.3	47	23032-00	Shaft	1	
1.3	48	11073-26	Pin, roll	1	
1.3	49	23030-00	Washer, stop	1	
1.3	50	23061-00	Housing, head	1	
1.3	51	23044-02	Bar, lower	1	
1.3	52	23044-01	Bar, raise	1	
1.3	53	23044-00	Bar, horn	1	
1.3	54	49506-03	Heater, 24 VOLT (COLD STORAGE)	1	
1.3	55	23460-00	Potentiometer	1	
1.3	56	49607-00	Plug, diode	1	
1.3	57	27312-00	Harness, head wiring	1	
1.3	58	23459-00	Harness, main wiring	1	

FIG #	ITEM #	PART #	NAME	# FOR ASSY.	UNIT
2.3	1	23400-00	Harness, main wiring	1	
2.3	2	11880-08	Screw, machine	2	
2.3	3	20208-00	Switch, brake interlock	1	
2.3	4	14986-03	Nut, twin	1	
2.3	5	49815-00	Hourmeter	1	
2.3	6	20163-87	Wire assembly	1	
2.3	7	20163-91	Wire assembly	1	
2.3	8	20163-90	Wire assembly	1	
2.3	9	20151-00	Switch, key	1	
2.3	10	23228-00	Indicator, battery discharge (BDI) 12V	1	12 VOLT
2.3	10	23228-01	Indicator, battery discharge (BDI) 24V	1	24 VOLT
2.3	11	20163-88	Wire assembly	1	
2.3	12	14928-00	Holder, fuse (part of wiring harness)	1	
2.3	13	25275-07	Fuse, 10 AMP	1	
2.3	14	23425-00	Pump & motor assembly, 12V hydraulic (See Fig.# 3.5)	1	12 VOLT
2.3	14	23424-00	Pump & motor assembly, 24V hydraulic (See Fig.# 3.5)	1	24 VOLT
2.3	15	23314-00	Control panel assembly, 12 Volt (See Fig.# 2.5)	1	12 VOLT
2.3	15	23314-02	Control panel assembly, 24 Volt (See Fig.# 2.5)	1	24 VOLT
2.3	16	23401-00	Harness, frame wiring	1	
2.3	17	49751-04	Nut	1	
2.3	18	11016-02	Washer, flat	1	
2.3	19	23309-00	Horn, 12 volt	1	12 VOLT
2.3	19	23309-01	Horn, 24 volt	1	24 VOLT
2.3	20	25332-00	Tie, wire	As Req'd.	
2.3	21	14986-03	Nut, twin	1	
2.3	22	20208-00	Switch, lift limit	1	
2.3	23	11880-08	Screw, machine	2	
2.3	24	301445-000	Indicator, BDI/Hourmeter (OPTIONAL)	1	12 VOLT
2.3	24	301445-001	Indicator, BDI/Hourmeter (OPTIONAL)	1	24 VOLT
2.3	25	11261-02	Nut	2	
2.3	26	11009-02	Lockwasher	2	
2.3	27	49831-00	Thermostat	1	
2.3	28	11016-23	Washer, flat	2	
2.3	29	11881-04	Screw, machine	2	
2.3	30	23040-00	Switch	3	
2.3	31	49506-00	Heater, 12 volt (cold storage)	1	12 VOLT
2.3	31	49506-01	Heater, 24 volt (cold storage)	1	24 VOLT
2.3	32	49607-00	Plug, diode	1	
2.3	33	23081-00	Harness, head wiring	1	
2.3	34	23040-00	Switch, reverser	1	
2.3	35	23369-00	Switch, master	1	

FIGURE # 2.9 TRANSISTOR ELECTRICAL SCHEMATIC SYMBOLS

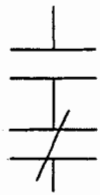

DOUBLE TIP CONTACTOR

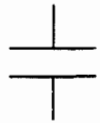

SINGLE TIP CONTACTOR

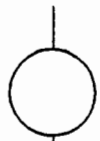

COIL



CONTROL SWITCH

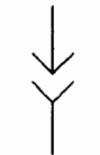

PLUG

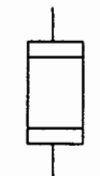

FUSE



ARMATURE

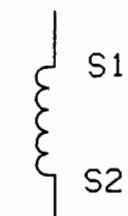

FIELD



TERMINAL NUMBER



DIODE



CAPACITOR

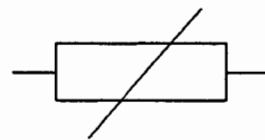

THERMAL PROTECTOR



RESISTOR



TRANSFORMER

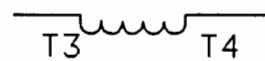

ELECTRICAL LINE JOINING

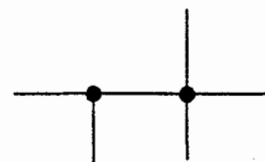

ELECTRICAL LINE CROSSING



SB-175 \* 49855-33 \* 12 VOLT \* YELLOW

FIG ITEM		PART #	NAME	# FOR ASSY.	UNIT
#	#				
2.14	1	49855-33	Connector assembly SB-175 YELLOW	1	
2.14	2	49854-03	Connector, YELLOW housing	1	
2.14	3	49852-01	Connector, tip	2	
2.14	4	49853-02	Bushing	2	
2.14	5	49856-88	Cable, 29.50" NEGATIVE	1	
2.14	6	49856-87	Cable, 23.75" POSITIVE	1	

SB-175 \* 49855-34 \* 24 VOLT \* RED

FIG ITEM		PART #	NAME	# FOR ASSY.	UNIT
#	#				
2.14	1	49855-34	Connector assembly SB-175 RED	1	
2.14	2	49854-04	Connector, RED housing	1	
2.14	3	49852-01	Connector, tip	2	
2.14	4	49853-02	Bushing	2	
2.14	5	49856-88	Cable, 29.50" NEGATIVE	1	
2.14	6	49856-87	Cable, 23.75" POSITIVE	1	

SB-175 \* 49855-17 \* 12 VOLT \* GRAY

FIG ITEM		PART #	NAME	# FOR ASSY.	UNIT
#	#				
2.14	1	49855-17	Connector assembly SB-175 GRAY	1	
2.14	2	49854-01	Connector, GRAY housing	1	
2.14	3	49852-01	Connector, tip	2	
2.14	4	49853-02	Bushing	2	
2.14	5	49856-88	Cable, 29.50" NEGATIVE	1	
2.14	6	49856-87	Cable, 23.75" POSITIVE	1	

SB-175 \* 49855-17 \* 24 VOLT \* GRAY

FIG ITEM		PART #	NAME	# FOR ASSY.	UNIT
#	#				
2.14	1	49855-17	Connector assembly SB-175 GRAY	1	
2.14	2	49854-01	Connector, GRAY housing	1	
2.14	3	49852-01	Connector, tip	2	
2.14	4	49853-02	Bushing	2	
2.14	5	49856-88	Cable, 29.50" NEGATIVE	1	
2.14	6	49856-87	Cable, 23.75" POSITIVE	1	

FIG #	ITEM #	PART #	NAME	# FOR ASSY.	UNIT
3.3	1	23023-00	Cylinder assembly (See Fig.# 3.4)	1	
3.3	1	23023-01	Cylinder assembly (lube package & cold storage) (See Fig.# 3.4)	1	lube package & cold storage
3.3	2	49653-01	Fitting, 90°	1	
3.3	3	12391-05	O ring	1	
3.3	4	49604-01	O ring	1	
3.3	5	49517-00	Hose	1	
3.3	6	49656-01	Reducer	1	
3.3	7	49604-01	O ring	1	
3.3	8	12391-05	O ring	1	
3.3	9	23425-00	Hydraulic pump and motor assembly, 12 Volt (See Fig.# 3.5)	1	12 VOLT
3.3	9	23424-00	Hydraulic pump and motor assembly, 24 Volt (See Fig.# 3.5)	1	24 VOLT
3.3	10	11143-04	Screw, cap	2	
3.3	11	11009-06	Lockwasher	2	
3.3	12	11016-13	Washer, flat	2	

FIG #	ITEM #	12 VOLT	24 VOLT	NAME	# FOR ASSY. UNIT
5.1	1	23271-00	23271-00	Wrapper	1
5.1	2	27246-00	27246-00	Door	1
5.1	3	49922-01	49922-01	Screw, truss head	4
5.1	4	49751-06	49751-06	Nut, flange	2
5.1	5	49583-00	49583-00	Decal, warning	1
5.1	6	52-05009-00	52-05009-00	Edging, (3 feet)	As req'd
5.1	7	27233-02	27233-01	Charger, battery	1
5.1	*	204295	204294	Ampmeter	1
5.1	*	204296	204296	Capacitor	1
5.1	*	204297	204297	Breaker, 50 AMP circuit	1
5.1	*	204298	204298	Diode	1
5.1	*	204299	204299	Rectifier	1
5.1	*	204300	204300	Timer	1
5.1	8	-----	-----	Cable assembly (See Fig.# 5.2)	1
5.1	9	49504-00	49532-00	Decal, instruction	1
5.1	10	11854-03	11854-03	Screw, cap	2
5.1	11	11854-04	11854-04	Screw, cap	1
5.1	12	11016-02	11016-02	Washer, flat	1
5.1	13	11009-05	11009-05	Lockwasher	1
5.1	14	27234-00	27234-00	Battery	4
5.1	15	23274-00	23274-00	Case, battery	1
5.1	16	14851-02	14851-02	Nut, clip	2
5.1	17	49751-04	49751-04	Nut, flange	2
5.1	18	23281-00	23281-00	Tray, battery	1
5.1	19	23281-01	23281-01	Tray, battery	1
5.1	20	41520-00	41520-00	Mat, insulator	2
5.1	21	49443-00	49443-00	Decal, warning	1

CLICK HERE TO **DOWNLOAD** THE COMPLETE MANUAL

- Thank you very much for reading the preview of the manual.
- You can download the complete manual from: [www.heydownloads.com](http://www.heydownloads.com) by clicking the link below



- Please note: If there is no response to CLICKING the link, please download this PDF first and then click on it.

CLICK HERE TO **DOWNLOAD** THE COMPLETE MANUAL