



OPX30

● Parts Manuals

311346-000 June 01, 2002



CLICK HERE TO **DOWNLOAD** THE COMPLETE MANUAL

- Thank you very much for reading the preview of the manual.
- You can download the complete manual from: www.heydownloads.com by clicking the link below



- Please note: If there is no response to CLICKING the link, please download this PDF first and then click on it.

CLICK HERE TO **DOWNLOAD** THE COMPLETE MANUAL

5000**Electrical System**

5100-001 General electrical components (Chassis).....	73
5100-100 General electrical components (Platform)	75
5120-000 Lights	77
5160-000 Horn	79
5180-000 Static strap.....	81
5192-000 Battery connector	83
5201-000 Instrument panel.....	85
5290-000 Hourmeter.....	87
5310-000 Start / stop switch	89
5320-000 Travel direction switch	91
5390-000 Control cables / harness (Platform)	93
5390-200 Control cables / harness (Light and fan).....	95
5395-100 Control cables / harness (3 Stage mast)	97
5397-001 Control cables / harness (Chassis).....	99
5430-001 Motor power cables	101
5436-001 Contactor panel	103
5460-000 Drive controller	105
5610-000 Pump contactor	107
5511-001 Micro switches (lights, fan)	109
5630-000 Work Function contactor.....	111

6000**Hydraulic System**

6112-000 Hydraulic tank.....	115
6120-000 Supply hoses, mounting points.....	117
6125-100 3 Stage mast hoses, pipes, connections, mounting points.....	119
6140-000 Lift pump assembly.....	121
6220-000 Control valve.....	123
6615-100 3 Stage mast staging cylinder	125
6620-100 3 Stage mast free lift cylinder	127

7000**Operating Function - Lifting Device**

7105-001 Mast pivot	131
7116-100 3 Stage mast outer column.....	133
7117-100 3 Stage mast intermediate column	135
7118-100 3 Stage mast inner column	137
7130-100 Platform	139
7170-100 3 Stage mast lifting gear	141
7410-000 Fork assembly	143

0450-000

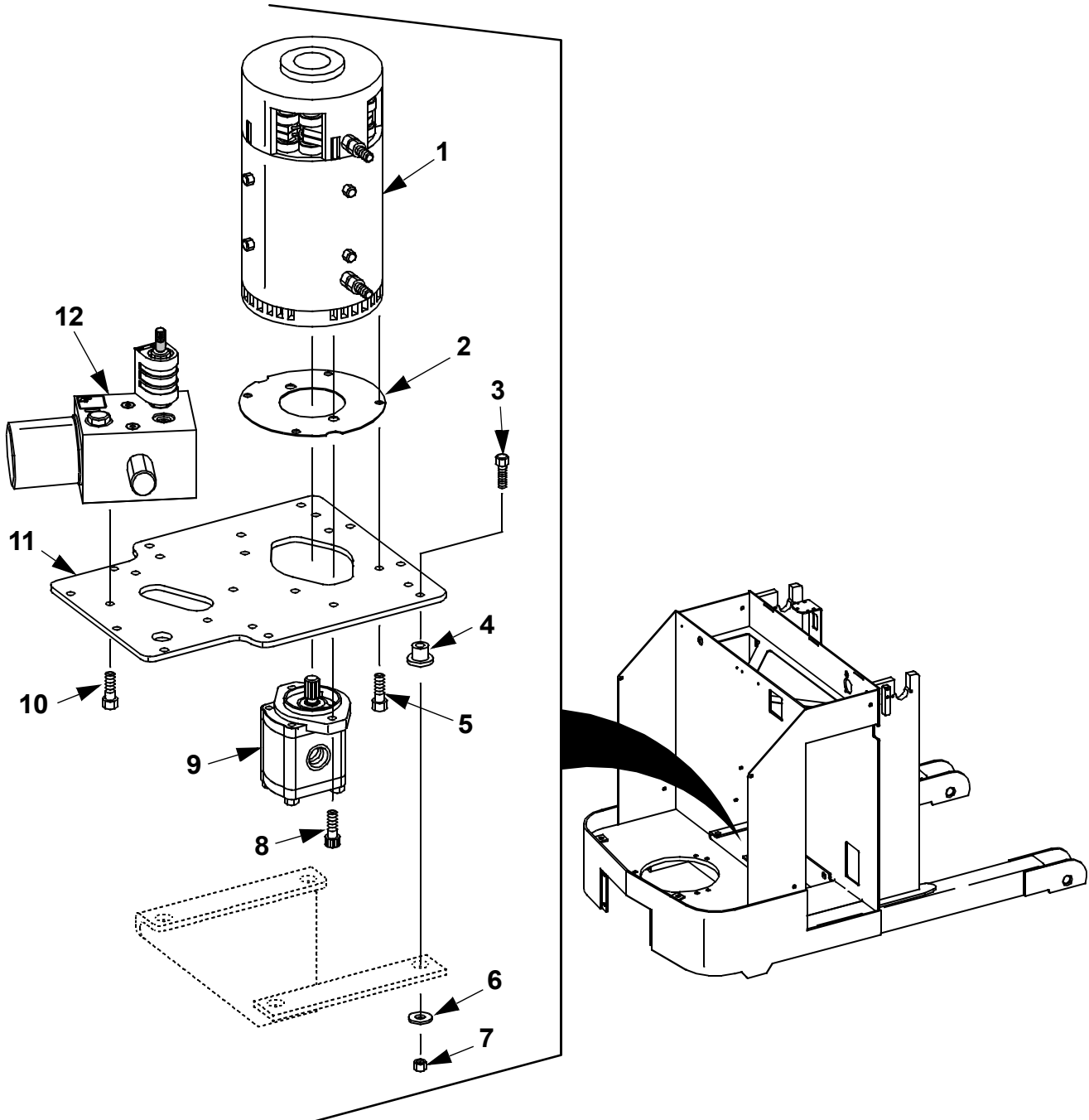

0820-000

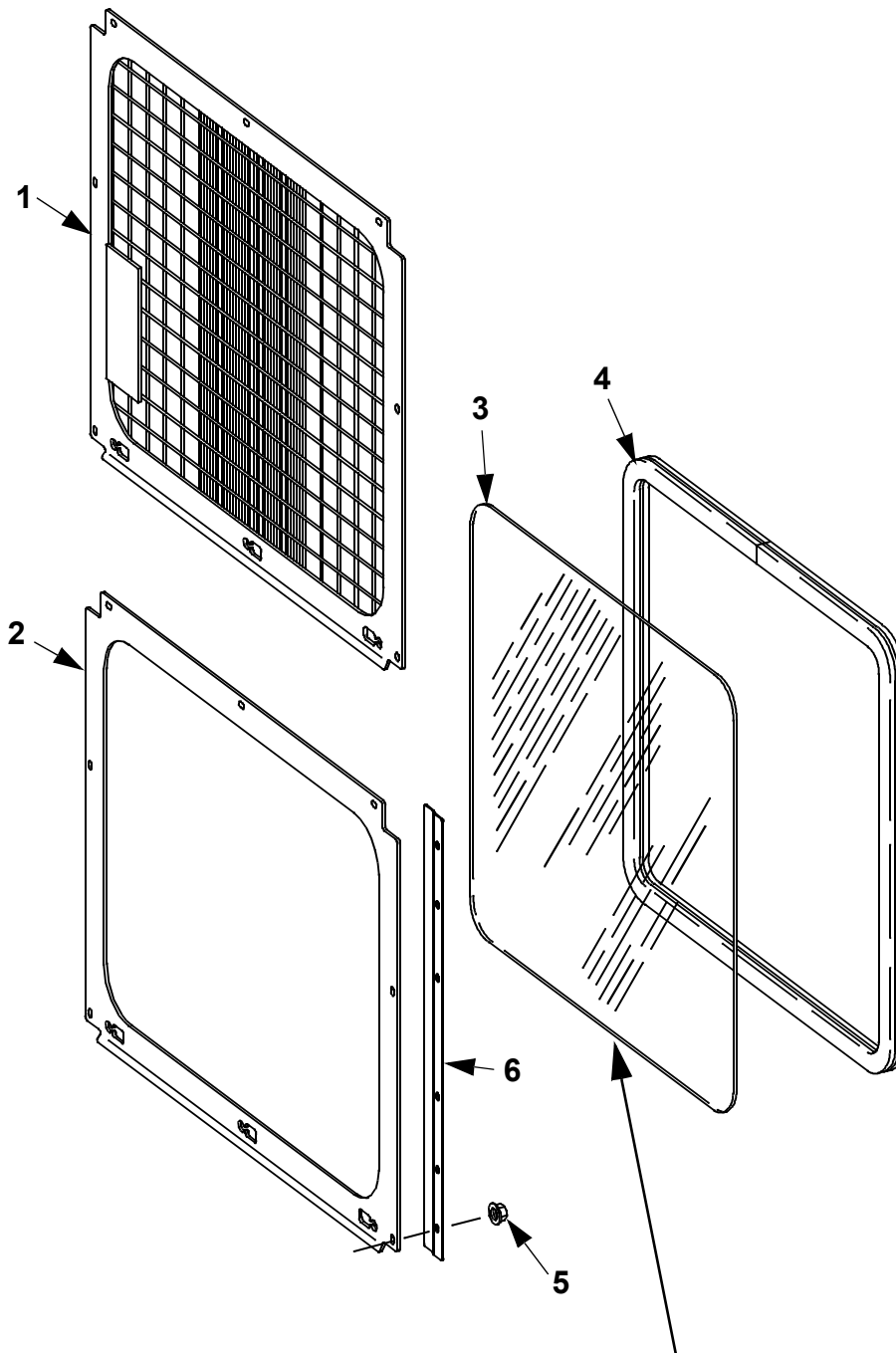

Laminated safety sheet glass S.A.E J-673

Windshield size for 83 inch (2108 mm) down height is
 31.87 inch x 21.40 inch x 0.234 inch - corner 2.56 inch
 (809.75 mm X 543.07 mm X 5.94 mm - corners 65 mm)

Windshield size for 87 inch (2210 mm) down height is
 31.87 inch x 25.40 inch x 0.234 inch - corner 2.56 inch
 (809.75 mm X 645.3 mm X 5.94 mm - corners 65 mm)

1750-100

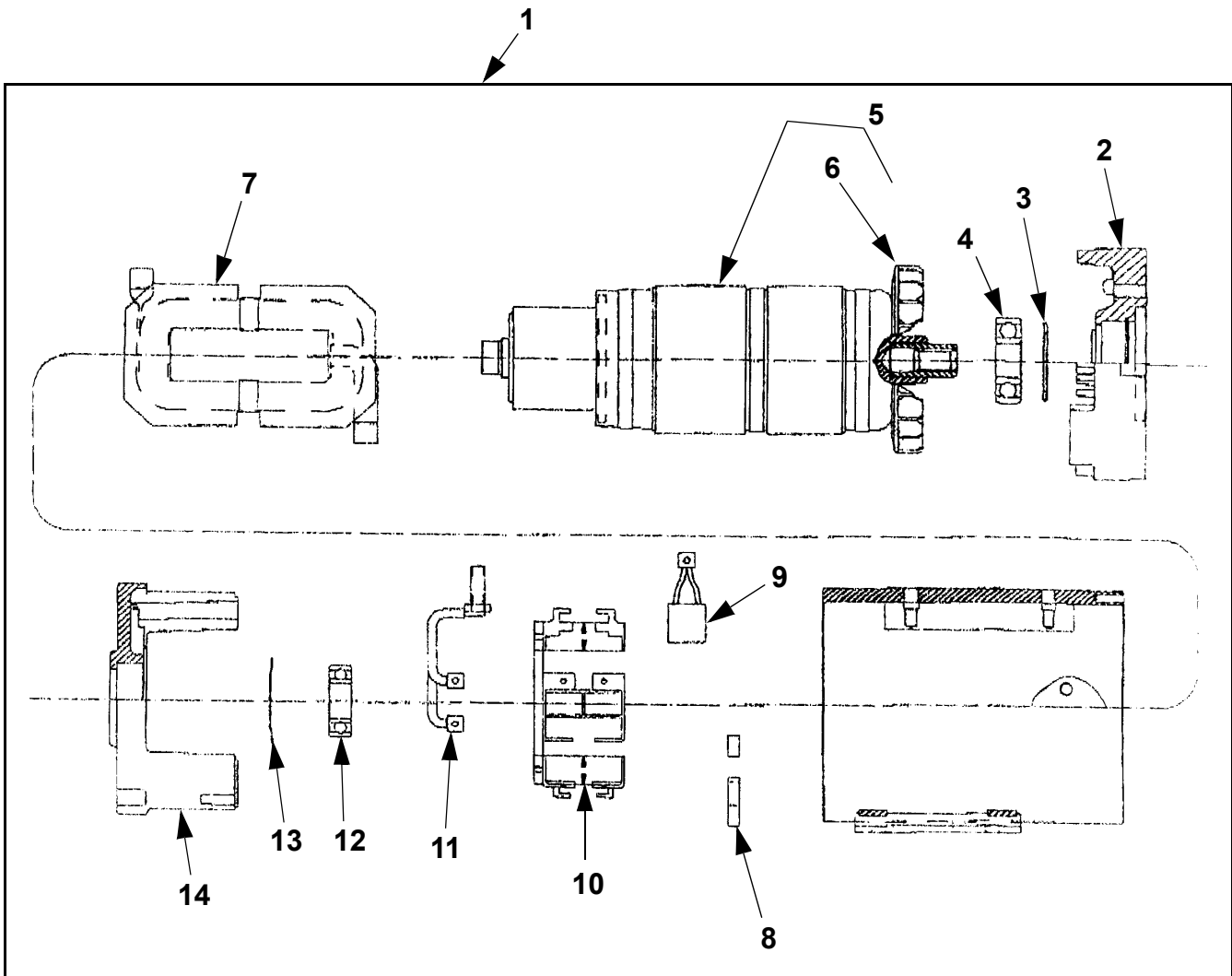

This page intentionally left blank

3550-100

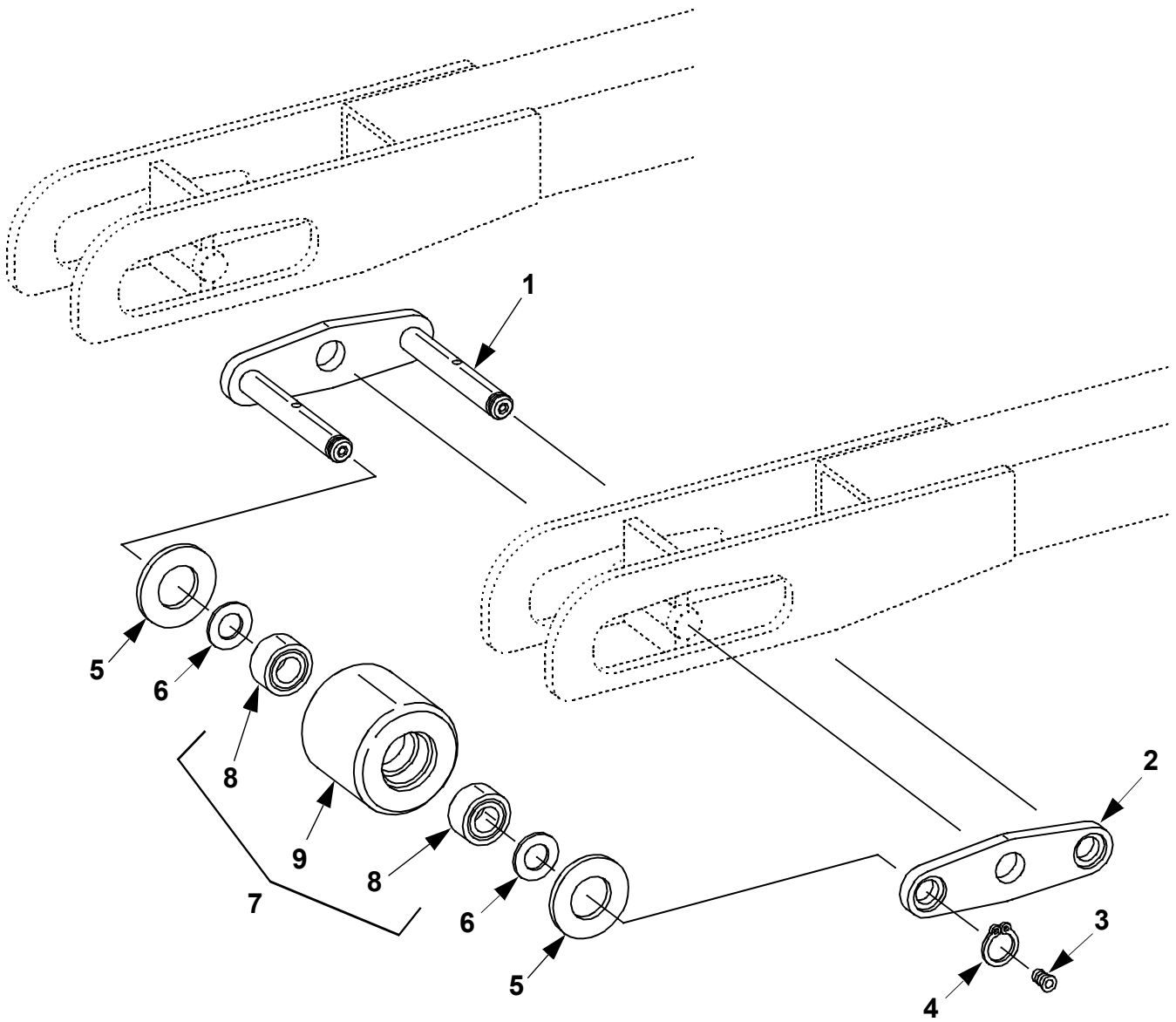

4330-000

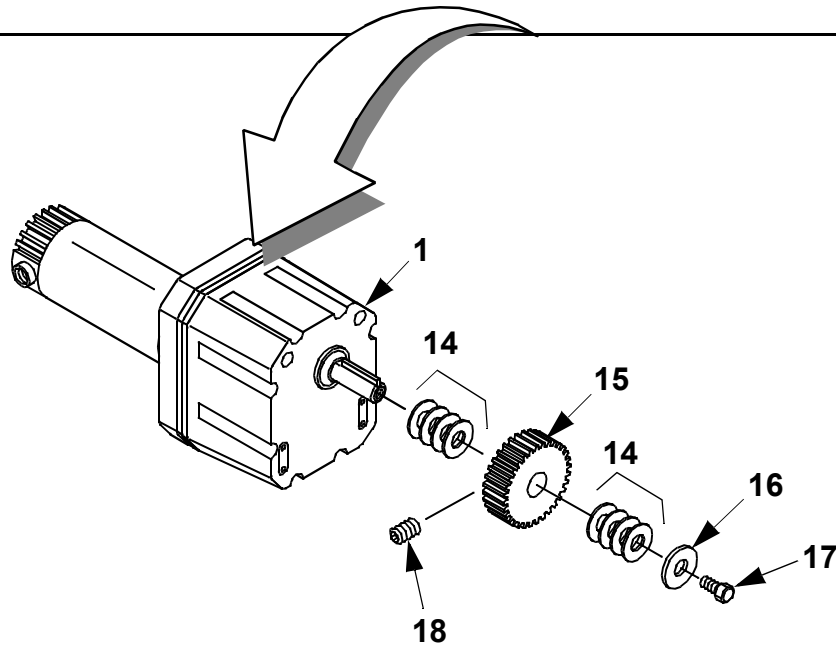
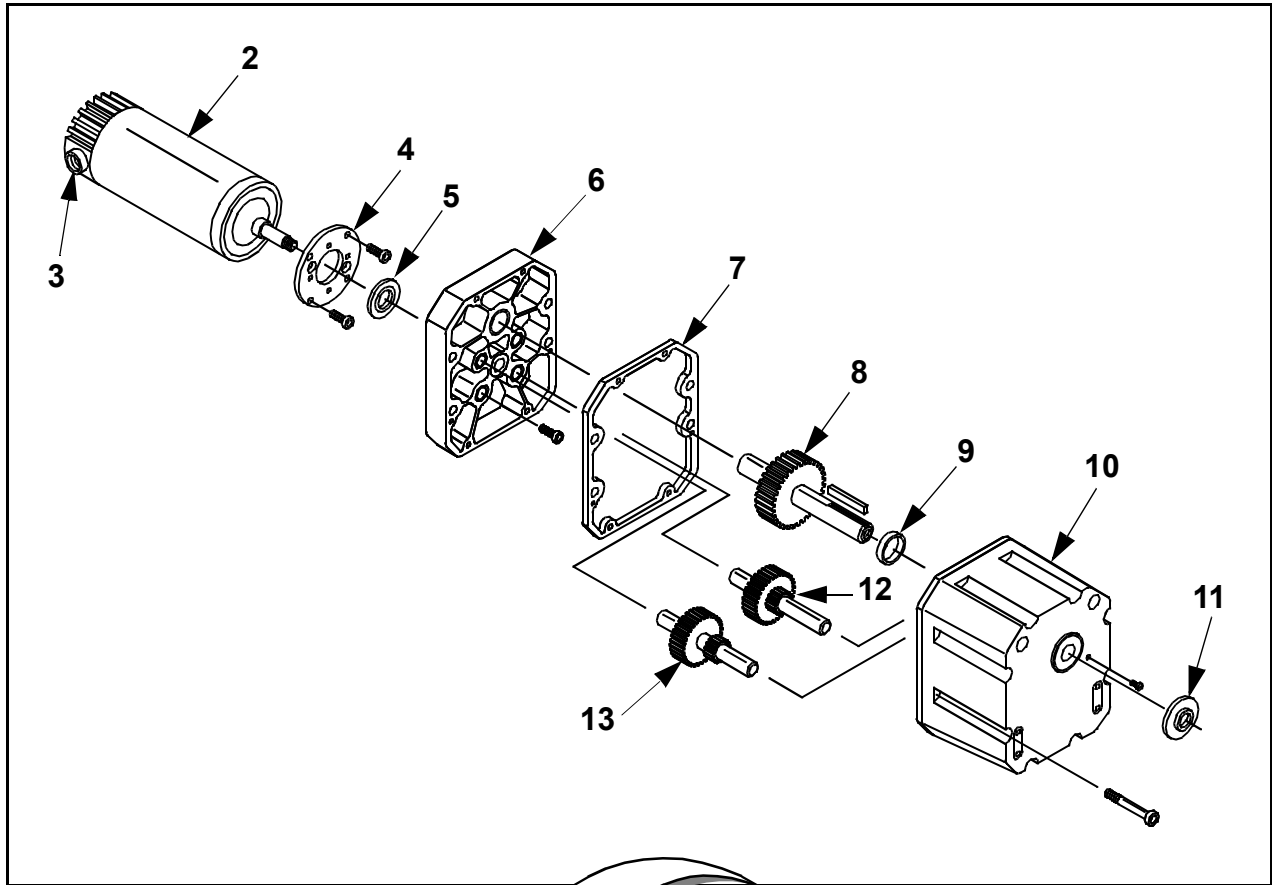

5160-000

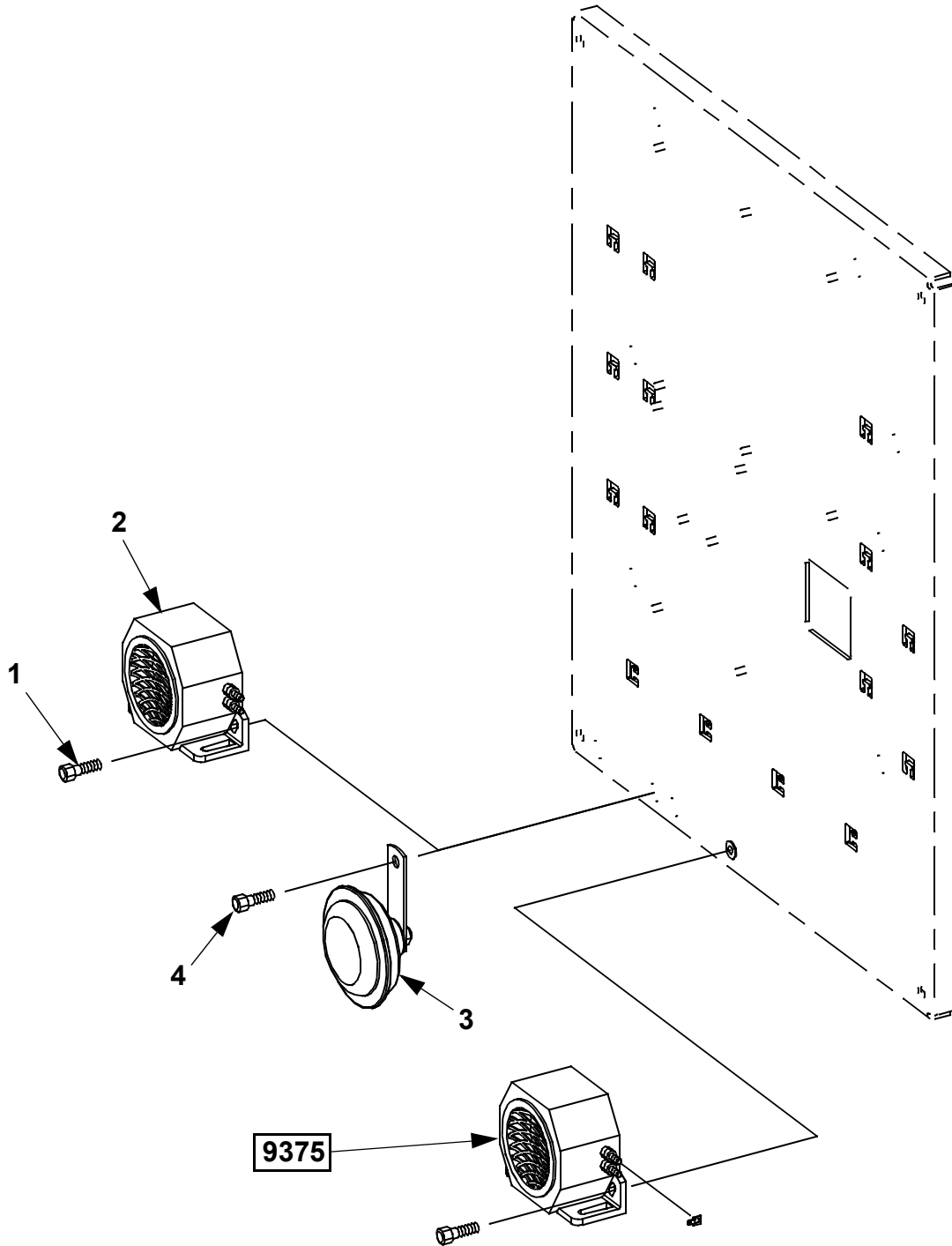

CLICK HERE TO **DOWNLOAD** THE COMPLETE MANUAL

- Thank you very much for reading the preview of the manual.
- You can download the complete manual from: www.heydownloads.com by clicking the link below



- Please note: If there is no response to CLICKING the link, please download this PDF first and then click on it.

CLICK HERE TO **DOWNLOAD** THE COMPLETE MANUAL

5310-000

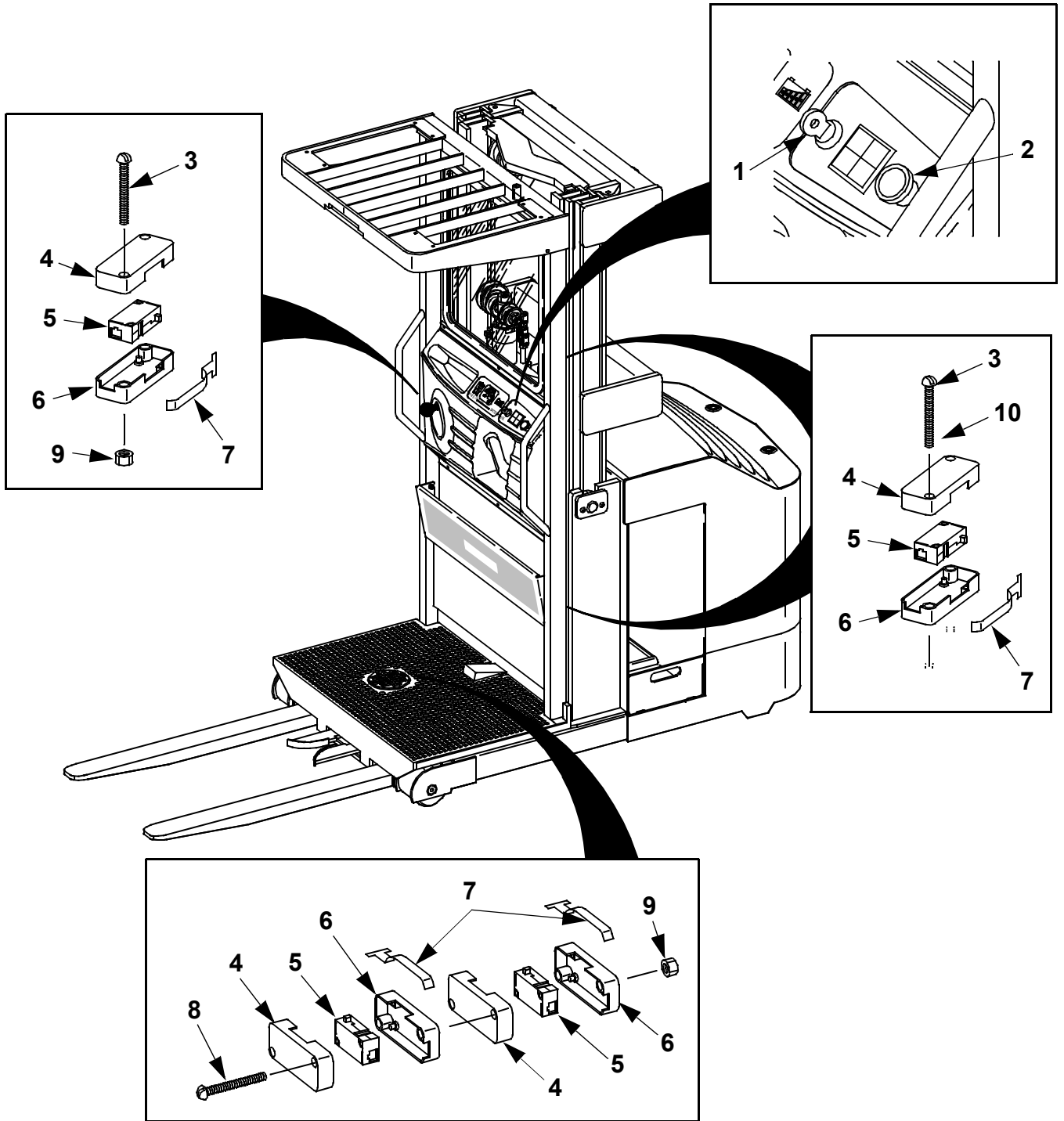

5397-001

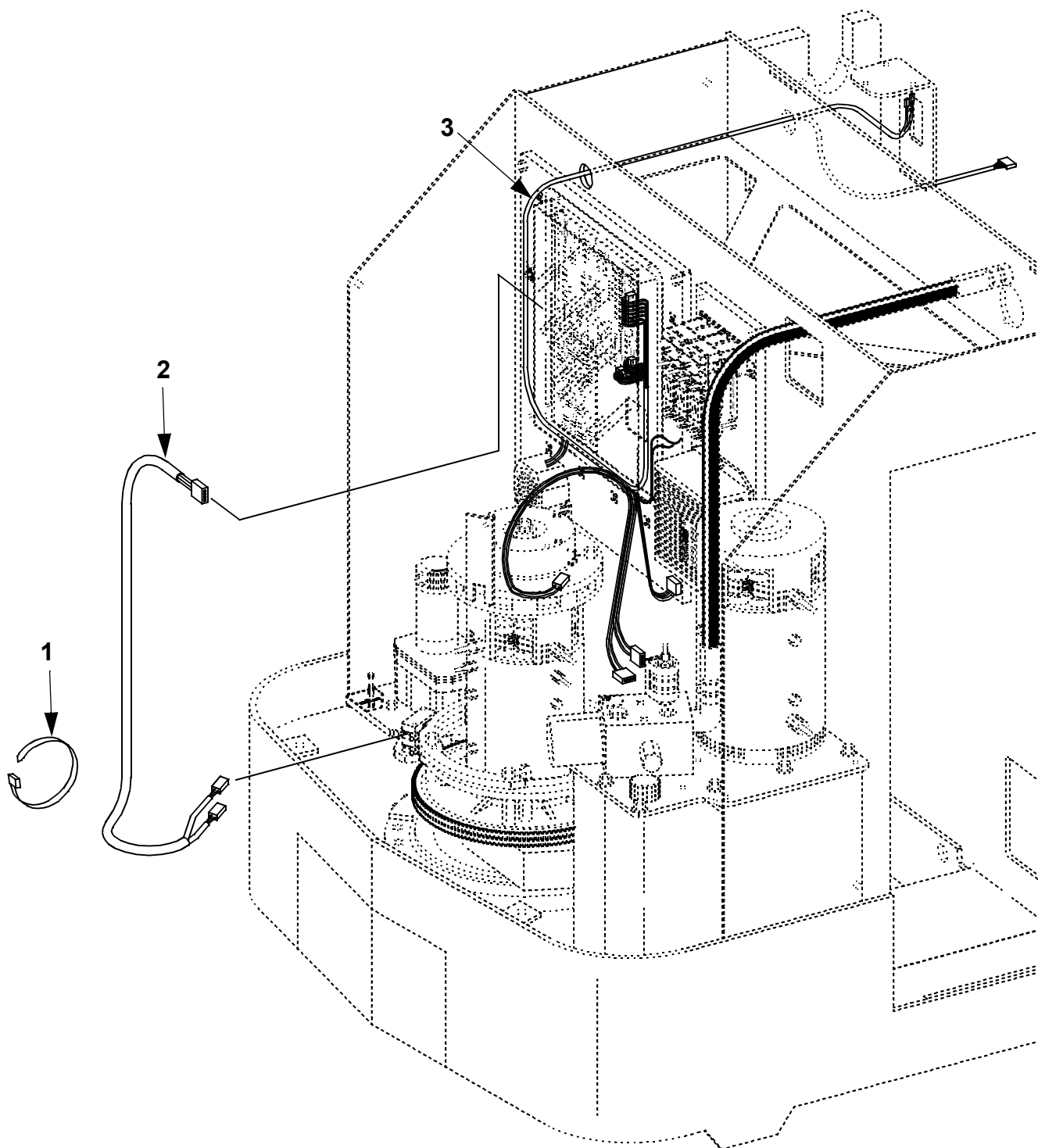

5511-001

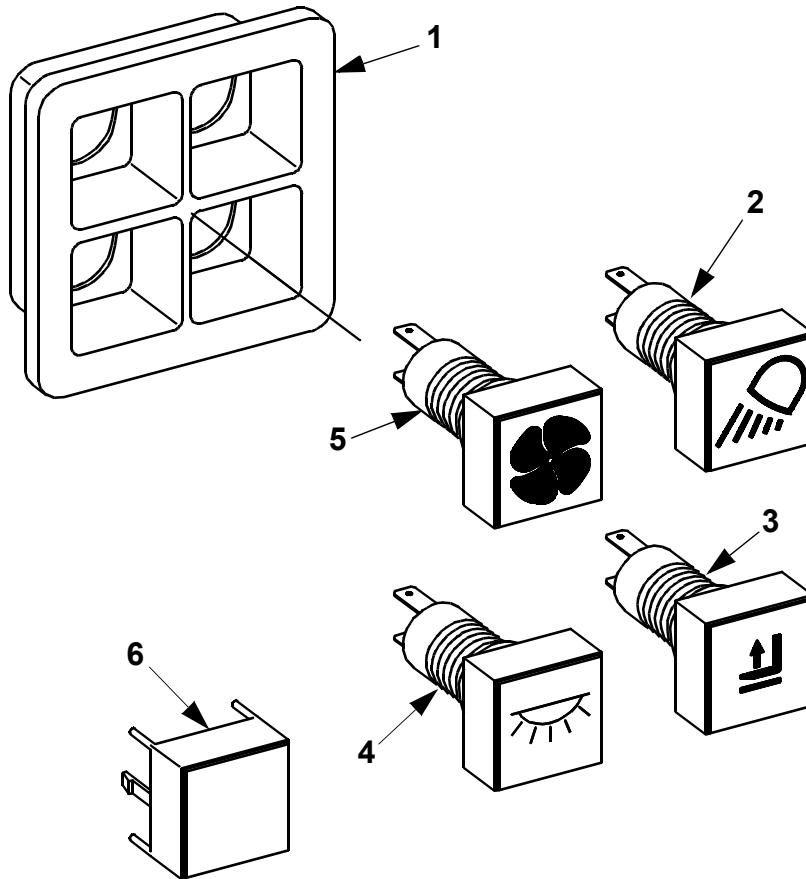

6125-100

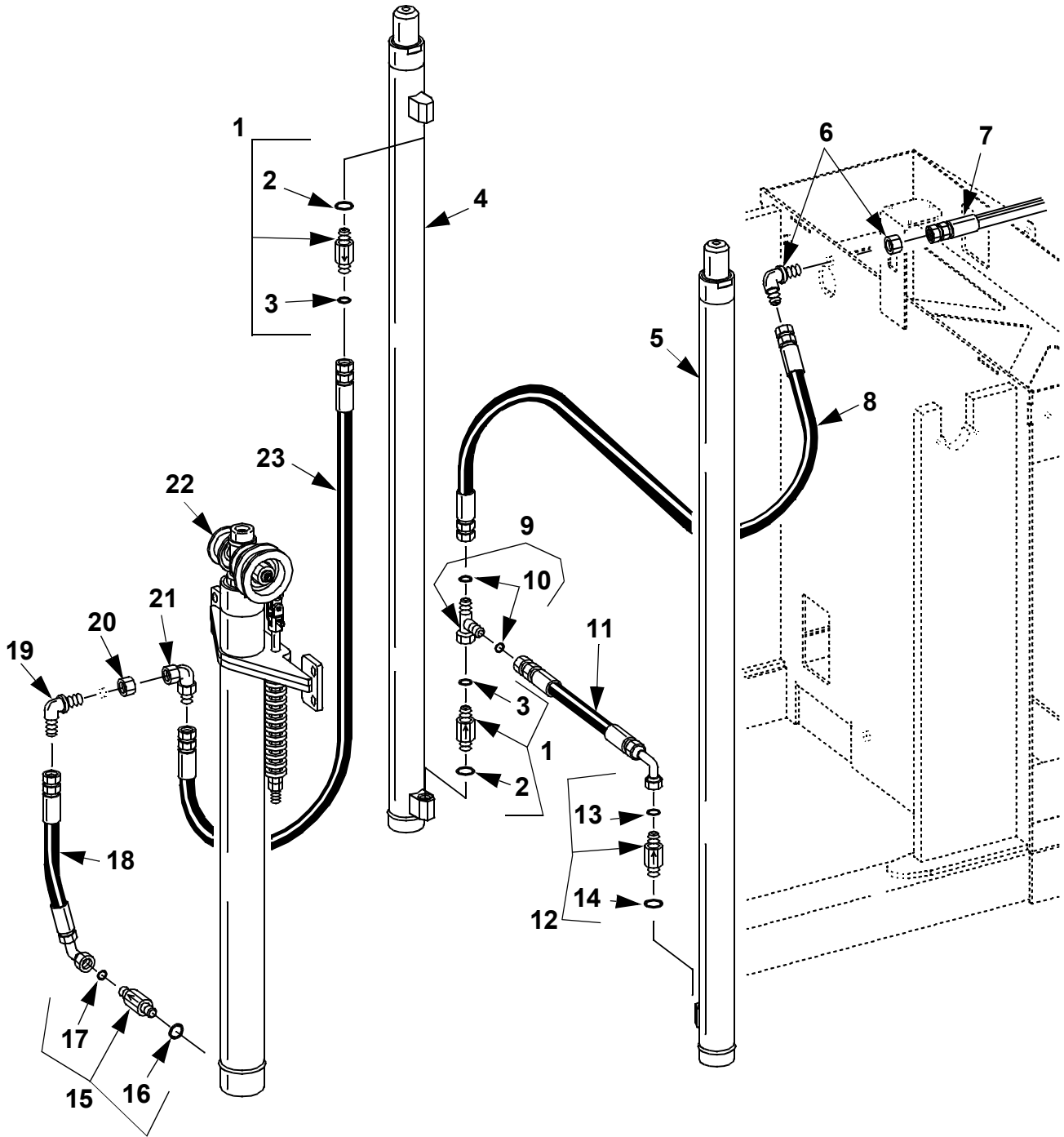

This page intentionally left blank

7130-100

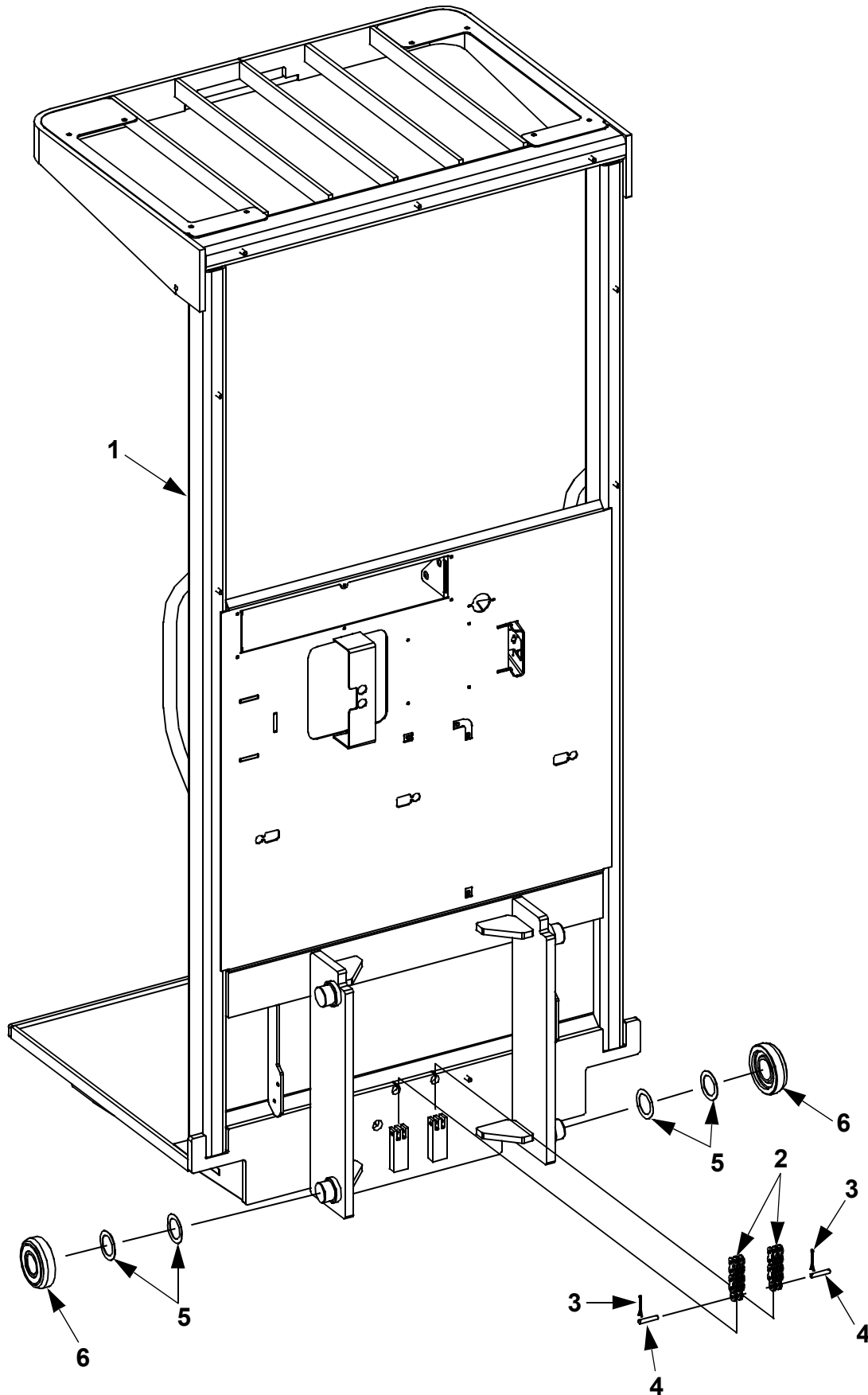

8520-000

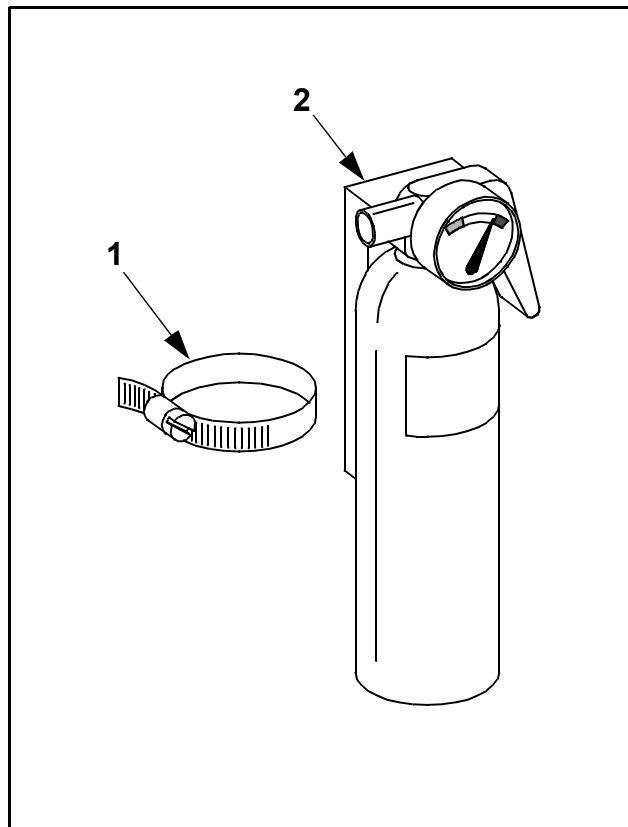

9370-000

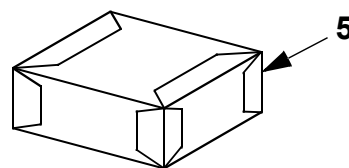
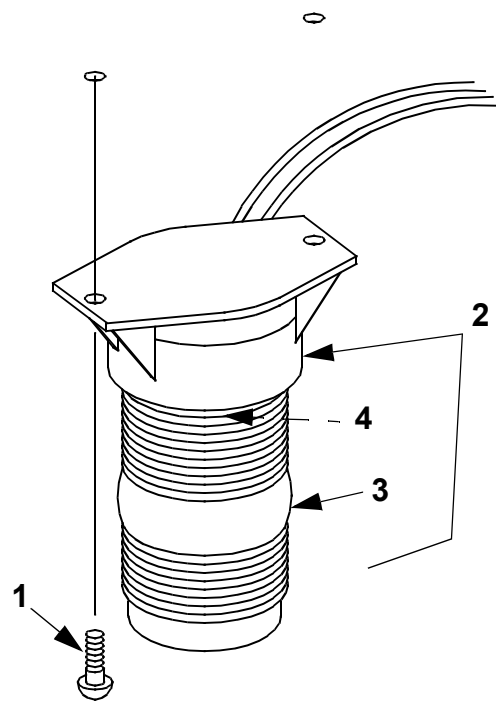

This page intentionally left blank

CLICK HERE TO **DOWNLOAD** THE COMPLETE MANUAL

- Thank you very much for reading the preview of the manual.
- You can download the complete manual from: www.heydownloads.com by clicking the link below



- Please note: If there is no response to CLICKING the link, please download this PDF first and then click on it.

CLICK HERE TO **DOWNLOAD** THE COMPLETE MANUAL