

## 目录/INDEX

检索编号 SECTION MARK CODE	零部件名称 DESCRIPTION	图样序号 DRAWING NO.	页码 PAGE
---------------------------	----------------------	---------------------	------------

### A 传动系统/DRIVE SYSTEM

A1	1t-1.5t	减速器总成	REDUCER ASSY	图1 Fig1	1
A2	2t-2.5t(DC)	减速器总成	REDUCER ASSY	图2 Fig2	3
A3	2t-3t(AC)	减速器总成	REDUCER ASSY	图3 Fig3	4
A4	1t-1.5t	差速器	DIFFERENTIAL	图4 Fig4	6
A5	2t-2.5t(DC)	差速器	DIFFERENTIAL	图5 Fig5	7
A6	2t-3t(AC)	差速器	DIFFERENTIAL	图6 Fig6	8
A7	1t-1.5t	驱动桥	DRIVE AXLE	图7 Fig7	9
A8	2t-2.5t(DC)	驱动桥	DRIVE AXLE	图8 Fig8	11
A9	2t-3t	驱动桥	DRIVE AXLE	图9 Fig9	12
A10	1t-1.5t	轮式制动器	WHEEL BRAKE	图10 Fig10	13
A11	2t-3t	轮式制动器	WHEEL BRAKE	图11 Fig11	15
A12	1t-1.5t	驱动轮	DRIVE WHEEL	图12 Fig12	17
A13	2t-2.5t	驱动轮	DRIVE WHEEL	图13 Fig13	18
A14	2t-2.5t	驱动轮	DRIVE WHEEL	图14 Fig14	19
A15	3t	驱动轮	DRIVE WHEEL	图15 Fig15	20

### B 电气系统/ELECTRIC SYSTEM

B1	1t-1.5t(DC)	电气系统	ELECTRIC SYSTEM	图16 Fig16	21
B2	1t-1.5t(AC)	电气系统	ELECTRIC SYSTEM	图17 Fig17	22
B3	2t-2.5t(DC)	电气系统	ELECTRIC SYSTEM	图18 Fig18	23
B4	2t-2.5t(AC)	电气系统	ELECTRIC SYSTEM	图19 Fig19	24
B5	3t(DC)	电气系统	ELECTRIC SYSTEM	图20 Fig20	25

检索编号 SECTION MARK CODE	零部件名称 DESCRIPTION	图样序号 DRAWING NO.	页码 PAGE
---------------------------	----------------------	---------------------	------------

CLICK HERE TO **DOWNLOAD** THE COMPLETE MANUAL

- Thank you very much for reading the preview of the manual.
- You can download the complete manual from: [www.heydownloads.com](http://www.heydownloads.com) by clicking the link below



- Please note: If there is no response to CLICKING the link, please download this PDF first and then click on it.

CLICK HERE TO **DOWNLOAD** THE COMPLETE MANUAL











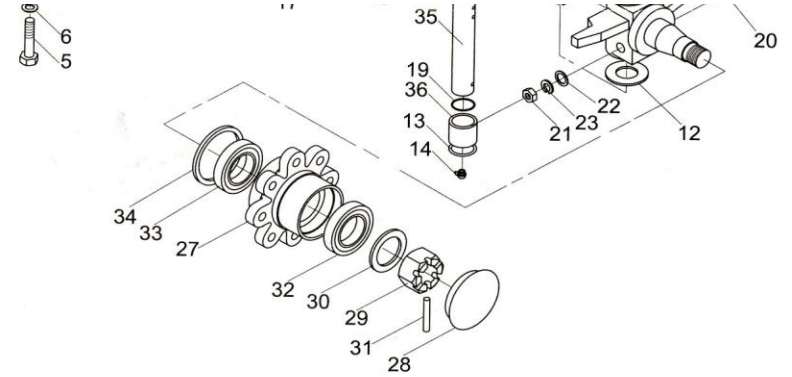

图56/FIG56 转向桥/STEERING AXLE

序号 No.	图号 Part No.	零部件名称 Description	件数 Q'ty	备注 Remark
A	A25PD420000	Steering axle assy 转向桥总成	1	2t,2.5t
B	30PD420000	Steering axle assy 转向桥总成	1	3t
01	A73E4-30001	Axle body assy 转向桥体总成	1	2t,2.5t
—	30PD421000	Axle body assy 转向桥体总成	1	3t
02	A73E4-32001	Link 连杆	2	
03	A73E4-50101	Steering cylinder 转向油缸	1	2t,2.5t
—	30PD422000	Steering cylinder 转向油缸	1	3t
04	A21B4-32171	Support 后桥支座	2	
05	A21B4-32181	Bushing 衬套	2	
06	A73E4-30301	Right steering knuckle 右转向节	1	
07	Z-198906	Bearing 轴承 $\Phi 32.1 \times \Phi 58 \times 16$	2	
08	Z-943/32	Bearing 轴承 $\Phi 32 \times \Phi 40 \times 32$	4	
09	A73J4-32111	King Pin 转向节主销	2	
10	Q701B90	Fitting 弯颈式滑脂嘴	6	
11	A73J4-32022	Link pin 连杆销	4	
12	B6150-00016	Snap ring 挡圈	16	8
13	H24C4-32061	Bearing 关节轴承	4	
14	H24C4-12003	Bushing 衬套	4	
15	GB13871-92	Seal ring 密封圈 $B75 \times 100 \times 10$	2	
16	Z-7509E	Bearing 轴承 $\Phi 45 \times \Phi 85 \times 24.75$	2	
17	Z-7207E	Bearing 轴承 $\Phi 35 \times \Phi 72 \times 18.25$	2	
18	B4116-00030	Nut 螺母 M20x2	2	
19	GB97.1-85	Washer 垫圈 30	2	

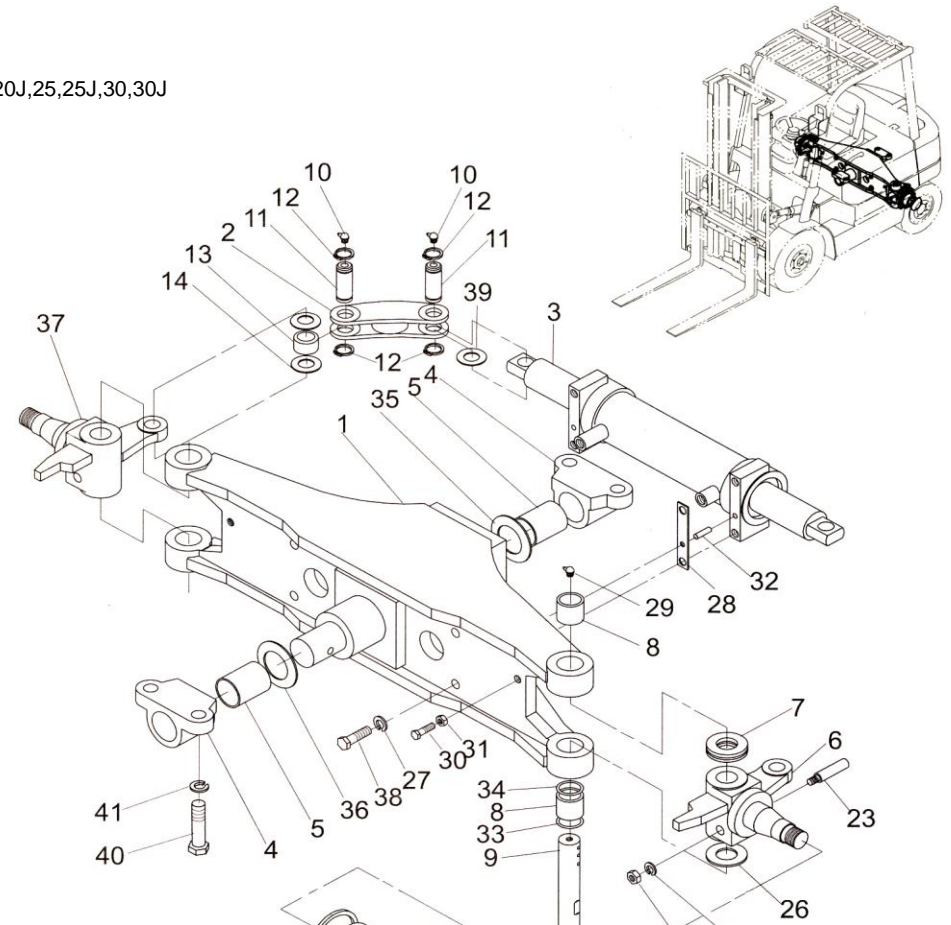

D5

CPD20,20J,25,25J,30,30J





No.	Part No.	Description	Q'ty	Remark	CPD30
01	214A7-42001	Lift knob 起升手柄	1		
02	30CX621000-1	Lift lever 起升阀杆	1		
03	30CX620001-1	Bracket, lever 阀杆支架	1		
04	GB/T6170	Nut 螺母 M8	6		
05	GB/T93	Washer 垫圈 8	4		
06	GB/T96	Washer 垫圈 8-140HV	4		
07	GB/T5781	Bolt 螺栓 M8×20-4.8	4		
08	30CX622000	Pin 销轴总成	1		
09	GB/T93	Washer 垫圈 6	1		
10	GB/T5781	Bolt 螺栓 M6×12-4.8	1		
11		Bushing 衬套 1638	2		
12	30CX621000-2	Tilt lever 倾斜阀杆	1		
13	214A7-42011	Tilt knob 倾斜手柄	1		
14	30CX620006	Pin 销轴 B5×18	4		
15	GB/T97.1	Washer 垫圈 6-140HV	4		
16	GB/T91	Pin 销 2×12	4		
17	A20PD620002	Joint lever 多路阀操纵连接杆	1		
18	30CX620007	Link yoke 连接叉	2		
19	CDB2-F15D-A020	Control valve 多路阀	1		
20	30CX620005	Sleeve 减震垫套	3		
21	30CX620004	Bumper 减震垫	3		
22	GB/T96	Washer 垫圈 10-140HV	3		
23	GB/T93	Washer 垫圈 10	3		
24	GB/T5785	Bolt 螺栓 M10×40	3		
25	YBLXW-ZL/15G030	Inching switch 微动开关	3		
26	15PD610100	Seat, lift switch 起升开关支座	2		
27	A20PD620003	Protection hood 微动开关防护罩	2		
28	GB/T5780	Bolt 螺栓 M4×30-4.8	4		
29	GB/T97.1	Washer 垫圈 4-140HV	4		
30	GB/T6170	Nut 螺母 M4-6	4		

图73/FIG73 操纵杆总成(二片)/VALVE CONTROL LINKAGE(TWO-THROW)

序号 No.	图号 Part No.	零部件名称 Description	件数 Q'ty	备注 Remark	CPD30
31	30PD800001	Fixed plate 行程开关固定板	1		
32	30PD620100	Joint lever 多路阀操纵连接杆总成	1		

F5

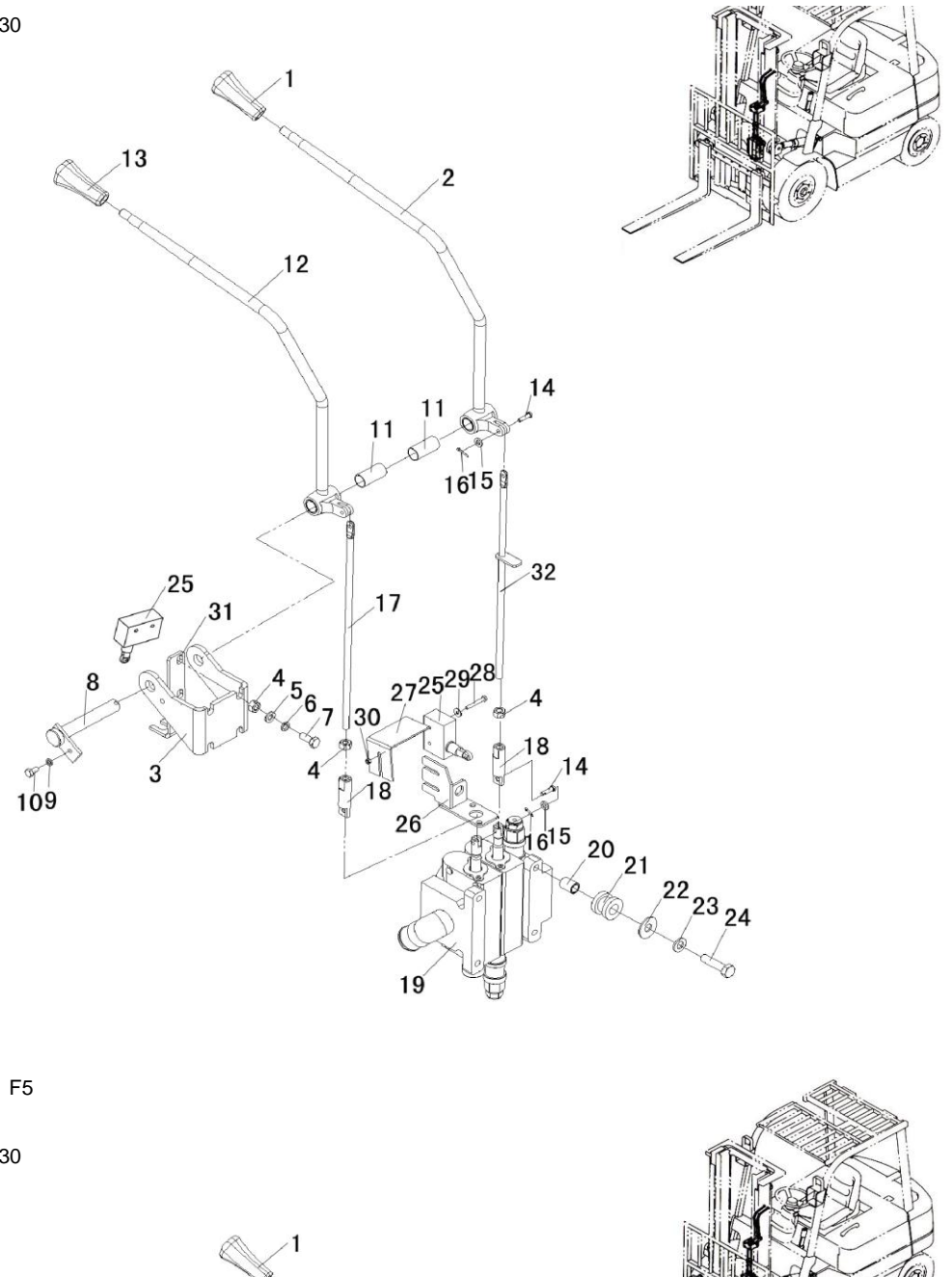







CLICK HERE TO **DOWNLOAD** THE COMPLETE MANUAL

- Thank you very much for reading the preview of the manual.
- You can download the complete manual from: [www.heydownloads.com](http://www.heydownloads.com) by clicking the link below



- Please note: If there is no response to CLICKING the link, please download this PDF first and then click on it.

CLICK HERE TO **DOWNLOAD** THE COMPLETE MANUAL

























CLICK HERE TO **DOWNLOAD** THE COMPLETE MANUAL

- Thank you very much for reading the preview of the manual.
- You can download the complete manual from: [www.heydownloads.com](http://www.heydownloads.com) by clicking the link below



- Please note: If there is no response to CLICKING the link, please download this PDF first and then click on it.

CLICK HERE TO **DOWNLOAD** THE COMPLETE MANUAL