

TB145

Book No. BK3Z010
Serial No. 14510004-

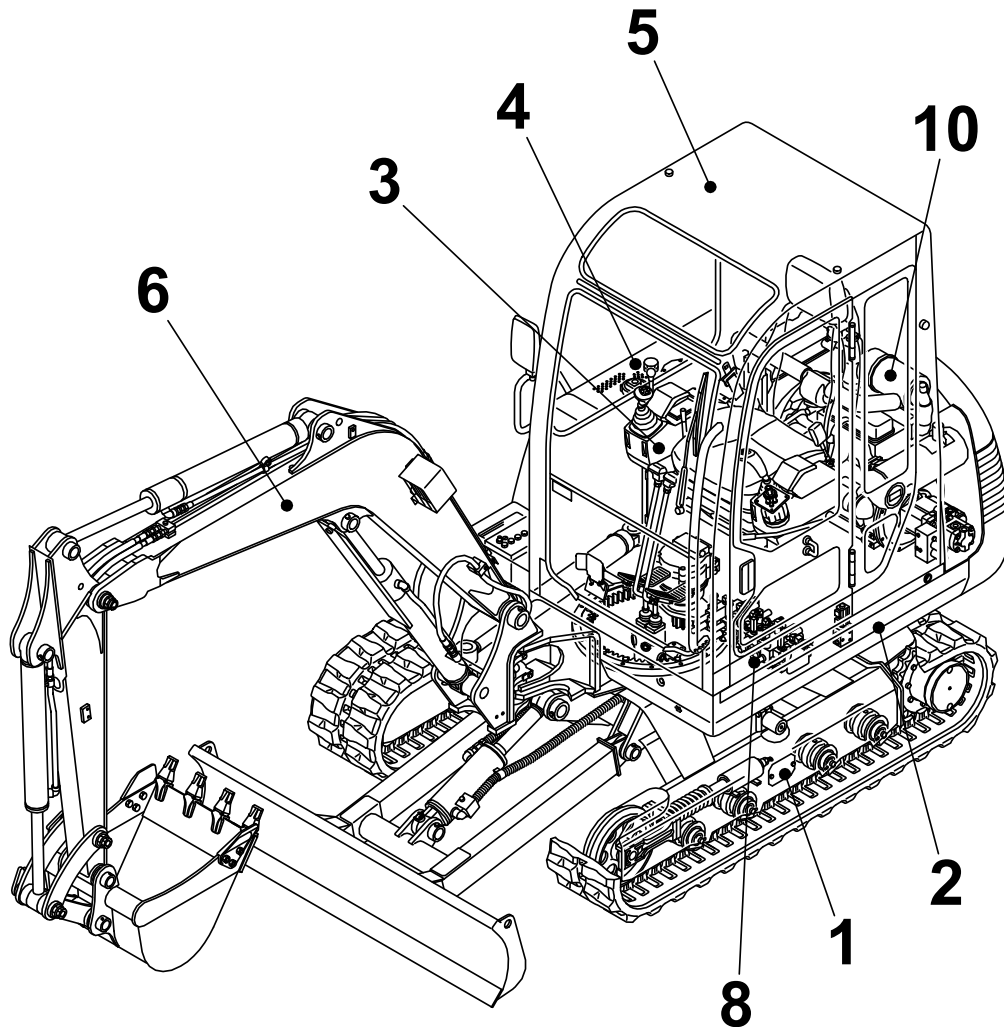

TAKEUCHI

CLICK HERE TO **DOWNLOAD** THE COMPLETE MANUAL

- Thank you very much for reading the preview of the manual.
- You can download the complete manual from: www.heydownloads.com by clicking the link below



- Please note: If there is no response to CLICKING the link, please download this PDF first and then click on it.

CLICK HERE TO **DOWNLOAD** THE COMPLETE MANUAL

CARRIER ROLLER (14513279-)

| Item | Part number | Description | Q'ty | Chan. | Serial No. | Serv. | Remarks |
|------|-------------------|----------------------|------|-------|------------|-------|----------------|
| | | ROLLER ASSY, carrier | | | | | X03912-00000-2 |
| 0-1 | 0391200100 | ROLLER SUB ASSY | 2 | | | | |
| 1 | 0391200110 | ▪ ROLLER | 1 | | | | |
| 2 | 0391200120 | ▪ SHAFT | 1 | | | | |
| 3 | 0141201300 | ▪ COVER | 1 | | | | |
| 4 | 1431203062 | ▪ SEAL | 1 | | | | |
| 5 | 1300006206 | ▪ BEARING | 2 | | | | |
| 6 | 1221000062 | ▪ RING, snap | 1 | | | | |
| 7 | 1501820001 | ▪ PLUG | 1 | | | | |
| 8 | 1101041670 | BOLT | 2 | | | | |
| 9 | 1130540016 | NUT | 2 | | | | |
| | K3a141 | | | | | | |

TRAVEL DEVICE

| Item | Part number | Description | Q'ty | Chan. | Serial No. | Serv. | Remarks |
|------|-------------------|--------------------|------|-------|-------------------|-------|----------------|
| | | MOTOR ASSY, travel | | | | | X03916-06000-0 |
| 1 | 1903119500 | MOTOR, travel | 2 | | 14510004~14512498 | | |
| | 1903123000 | MOTOR, travel | 2 | (H) | 14512499~14515345 | | |
| | 1903124800 | MOTOR, travel | 2 | | 14515346~ | | |
| 2 | 0261603100 | SPROCKET | 2 | | | | |
| 3 | 1100051435 | BOLT | 36 | | | | |
| 4 | 1515600200 | ADAPTOR | 4 | | | | |
| | 1420010110 | • O-RING | 1 | | | | |
| 5 | 1515600202 | ADAPTOR | 4 | | | | |
| | 1420010180 | • O-RING | 1 | | | | |
| | K3a082 | | | | | | |

PIPING; LOWER

| Item | Part number | Description | Q'ty | Chan. | Serial No. | Serv. | Remarks |
|------|-------------------|--------------------|------|-------|------------|-------|-------------------|
| | | PIPING ASSY, lower | | | | | X03972-01000-2 |
| 1 | 1801022124 | HOSE ASSY | 2 | | | | |
| 2 | 1801540124 | HOSE ASSY | 2 | | | | 18010-22132 |
| 3 | 0397201200 | HOSE ASSY | 2 | | | | |
| 4 | 1801620116 | HOSE ASSY | 1 | | | | |
| 5 | 1801620094 | HOSE ASSY | 1 | | | | |
| 6 | 0437200100 | GUARD | 2 | | | | |
| 7 | 1531350020 | PROTECTOR | 6 | | | | sold by the meter |
| 8 | 0397201100 | HOSE ASSY | 2 | | | | 18015-40124 |
| | K3a122 | | | | | | |

TURNTABLE (14510004-4513260)

| Item | Part number | Description | Q'ty | Chan. | Serial No. | Serv. | Remarks |
|------|-------------|-------------------------|------|-------|------------|-------|----------------|
| | | TURNTABLE ASSY (cab) | | | | | X03930-12000-2 |
| | | TURNTABLE ASSY (canopy) | | | | | X03930-13000-2 |
| 1 | X ***** | TURNTABLE | 1 | | | | |
| 2 | 0393009500 | COUNTERWEIGHT | 1 | | | | cab |
| 3 | 0393010500 | COUNTERWEIGHT | 1 | | | | canopy |
| 4 | 0173216600 | COVER | 1 | | | | |
| 5 | 0002400057 | BUSHING | 2 | | | | |
| 6 | 1101041635 | BOLT | 5 | | | | |
| 7 | 1141550016 | WASHER | 5 | | | | |
| 8 | 1560001675 | FITTING, grease | 2 | | | | |
| 9 | 0433010610 | SHIM t=1.0 | AR | | | | |
| 10 | 0433010620 | SHIM t=1.6 | AR | | | | |
| 11 | 0433010630 | SHIM t=2.3 | AR | | | | |
| 12 | 0433010640 | SHIM t=3.2 | AR | | | | |
| 13 | 0393009600 | ABSORBENT, noise | 1 | | | | |
| 14 | 0393009610 | ABSORBENT, noise | 1 | | | | |
| 15 | 0393009620 | ABSORBENT, noise | 1 | | | | |
| 16 | 0393009630 | ABSORBENT, noise | 1 | | | | cab |
| 17 | 0393009640 | ABSORBENT, noise | 1 | | | | |
| 18 | 0393009680 | ABSORBENT, noise | 1 | | | | canopy |
| 19 | 0393009660 | ABSORBENT, noise | 2 | | | | |
| 20 | 0393009670 | RUBBER | 1 | | | | |
| 21 | 1130040008 | NUT | 2 | | | | |
| 22 | 1141110008 | WASHER | 2 | | | | |
| 23 | 1140020008 | WASHER, spring | 2 | | | | |
| 24 | 0337017300 | GUARD | 1 | | | | |
| | K3b022 | | | | | | |

| Item | Part number | Description | Q'ty | Chan. | Serial No. | Serv. | Remarks |
|------|---------------|---|------|-------|------------|-------|---------|
| 79 | | <<NOTE>> | | | | | |
| 79 | | "A" is interchangeable with SET "a". | | | | | |
| 79 | | "B" is interchangeable with SET "b". | | | | | |
| | K3b046 | | | | | | |

OPERATION LEVER & STAND (canopy; 14513261-)

| Item | Part number | Description | Q'ty | Chan. | Serial No. | Serv. | Remarks |
|-------|--------------|---------------------------------|------|-------|-------------------|-------|--------------------|
| | | VALVE ASSY | | | | | X03951-13000-7 |
| | | VALVE ASSY (with 2nd aux. line) | | | | | X03951-13500-7 |
| 1 | 0395113200 | BOX, control (R.H.) | 1 | | 14513261~14514955 | | |
| | 0395113600 | BOX, control (R.H.) | 1 | | 14514956~ | | |
| 1-13 | 1333002010 | • BUSHING | 1 | | | | |
| 1-14 | 1333002015 | • BUSHING | 1 | | | | |
| 2 | 0395113300 | BOX, control (L.H.) | 1 | | 14513261~14514955 | | |
| | 0395113700 | BOX, control (L.H.) | 1 | | 14514956~ | | |
| 2-13 | 1333002010 | • BUSHING | 1 | | | | |
| 2-14 | 1333002015 | • BUSHING | 1 | | | | |
| 3 | 0335130300 | PLATE (R.H.) | 1 | | 14513261~14514955 | | |
| | 0395113400 | PLATE (R.H.) | 1 | | 14514956~ | | |
| 4 | 0335130400 | PLATE (L.H.) | 1 | | 14513261~14514955 | | |
| | 0395113450 | PLATE (L.H.) | 1 | | 14514956~ | | |
| 5 | 0375105300 | LEVER (R.H.) | 1 | | | | |
| 6 | 0375105400 | LEVER (L.H.) | 1 | | | | |
| 7 | 0335124700 | SHAFT | 2 | | | | |
| 8 | 0335124750 | SHAFT | 2 | | | | |
| 9 | X 0375105500 | REST, arm | 2 | | | | |
| 9-1 | 0375105510 | • URETHANE | 1 | | | | |
| 9-2 | 0375105520 | • PLATE | 1 | | | | |
| 9-3 | 1120530812 | • SCREW | 3 | | | | |
| 9-4 | 1140020008 | • WASHER, spring | 3 | | | | |
| 10 | 0335124900 | BOOT | 2 | | | | |
| 11 | 1513250202 | BUSHING | 4 | | | | |
| | 1420010110 | • O-RING | 1 | | | | |
| 12 | 0375104300 | BRACKET (R.H.) | 1 | | | | |
| 12-10 | 1333002015 | • BUSHING | 2 | | | | |
| 13 | 0375104400 | BRACKET (L.H.) | 1 | | | | |
| 13-10 | 1333002015 | • BUSHING | 2 | | | | |
| 14 | 0375105100 | LEVER | 2 | | | | |
| 15 | 0425105100 | SPRING | 2 | | 14513261~14514955 | | |
| 16 | 1512370012 | ADAPTOR | 2 | | | | |
| | 1420010110 | • O-RING | 1 | | | | |
| 17 | 1515100110 | ELBOW | 10 | | | | |
| | 1420010110 | • O-RING | 1 | | | | |
| 18 | 1650202300 | CAP | 2 | | | | |
| 19 | 1650204600 | GRIP (R.H.) (horn, decel) | 1 | | | | |
| 19-1 | 1650204601 | • COVER | 1 | | | | |
| 20 | 1650204700 | GRIP (L.H.) (A-B) | 1 | | | | |
| 20-1 | 1650204701 | • COVER | 1 | | | | |
| 21 | 1651101224 | STOPPER | 2 | | | | |
| 22 | 1653900057 | SPRING, gas | 2 | | | | |
| 23 | 1700000033 | SWITCH, safety | 2 | | | | |
| 24 | 1901745600 | VALVE, pilot | 2 | | | | |
| 25 | 0335120970 | BOLT | 2 | | | | |
| 26 | 1110040625 | SCREW, cap | 8 | | | | |
| 27 | 1111810610 | SCREW | 4 | | | | |
| 28 | 1110040816 | SCREW, cap | 4 | | | | |
| 29 | 1130040010 | NUT | 2 | | | | |
| 30 | 1130040012 | NUT | 2 | | | | |
| 31 | 1130140014 | NUT | 2 | | | | |
| 32 | 1141110006 | WASHER | 12 | | | | |
| 33 | 1140020008 | WASHER, spring | 8 | | | | |
| 34 | 1141110008 | WASHER | 8 | | | | |
| 35 | 0003609003 | WASHER | 4 | | | | |
| 36 | 1213000832 | PIN, spring | 2 | | | | |
| 37 | 1214000008 | PIN, snap | 4 | | | | |
| 38 | 1110040825 | SCREW, cap | 4 | | | | |
| 40 | 1100041020 | BOLT | 8 | | | | |
| 41 | 1140020010 | WASHER, spring | 8 | | | | |
| 43 | 1213000836 | PIN, spring | 2 | | | | |
| 44 | 1901746400 | VALVE, pilot (R.H.) | 1 | | | | with 2nd aux. line |
| 44-1 | 1901740402 | • SWITCH, button | 1 | | | | with 2nd aux. line |
| 45 | 1901746500 | VALVE, pilot (L.H.) | 1 | | | | with 2nd aux. line |
| 45-1 | 1901740402 | • SWITCH, button | 1 | | | | with 2nd aux. line |
| 46 | 0395113046 | SPONGE | 2 | | | | |

PIPING; OPERATION LEVER

| Item | Part number | Description | Q'ty | Chan. | Serial No. | Serv. | Remarks |
|------|-------------|----------------|------|-------|------------|-------|-------------------|
| | | PIPING ASSY | | | | | X03971-04000-6 |
| 1 | 0397104010 | HOSE ASSY | 1 | | | | 19348-22026 |
| 2 | 0397104020 | HOSE ASSY | 1 | | | | 19348-22038 |
| 3 | 0377104030 | HOSE ASSY | 1 | | | | 19348-22180 |
| 4 | 0397104040 | HOSE ASSY | 1 | | | | 19348-22210 |
| 5 | 0397104050 | HOSE ASSY | 1 | | | | 19348-22210 |
| 6 | 0397104060 | HOSE ASSY | 1 | | | | 19348-22235 |
| 7 | 0397104070 | HOSE ASSY | 1 | | | | 19348-22355 |
| 8 | 0397104080 | HOSE ASSY | 1 | | | | 19348-22365 |
| 9 | 0397104090 | HOSE ASSY | 1 | | | | 19348-22235 |
| 10 | 0397104100 | HOSE ASSY | 1 | | | | 19348-52062 |
| 11 | 0397104110 | HOSE ASSY | 1 | | | | 19348-52080 |
| 12 | 0397104120 | HOSE ASSY | 1 | | | | 19348-52205 |
| 13 | 0397104130 | HOSE ASSY | 1 | | | | 19348-52255 |
| 14 | 1531235030 | PROTECTOR | 1 | | | | sold by the meter |
| 15 | 1531645029 | PROTECTOR | 6 | | | | sold by the meter |
| 16 | 1567315030 | PROTECTOR | 2 | | | | sold by the meter |
| 17 | 0007300030 | CLAMP | 4 | | | | |
| 18 | 1100041016 | BOLT | 1 | | | | |
| 19 | 1130040008 | NUT | 1 | | | | |
| 20 | 1140020008 | WASHER, spring | 1 | | | | |
| 21 | 0397104140 | HOSE ASSY | 1 | | | | 19348-52060 |
| 22 | 0397104150 | HOSE ASSY | 1 | | | | 19348-52255 |
| 23 | 0397104160 | HOSE ASSY | 1 | | | | 19348-52205 |
| 24 | 0397104170 | HOSE ASSY | 1 | | | | 19348-72200 |
| 25 | 1140020010 | WASHER, spring | 3 | | | | |
| 26 | 1130040010 | NUT | 2 | | | | |
| 27 | 1652231250 | BAND | 3 | | | | M |
| 28 | 1652201007 | BAND | 2 | | | | M |

K3b073

PIPING; OPERATION LEVER (2/3) (multi pattern)

| Item | Part number | Description | Q'ty | Chan. | Serial No. | Serv. | Remarks |
|------|-------------|----------------|------|-------|------------|-------|-------------------|
| | | PIPING ASSY | | | | | X03971-07000-3 |
| 6 | 1901733700 | VALVE, rotary | 1 | | | | |
| 7 | 0397107010 | BRACKET | 1 | | | | |
| 9 | 1532208020 | PROTECTOR | 1 | | | | sold by the meter |
| 20 | 0397107200 | HOSE ASSY | 1 | | | | 19348-22046 |
| 21 | 0397107210 | HOSE ASSY | 1 | | | | 19348-22046 |
| 22 | 0397107220 | HOSE ASSY | 1 | | | | 19348-52106 |
| 23 | 0397107230 | HOSE ASSY | 1 | | | | 19348-52118 |
| 24 | 0397107240 | HOSE ASSY | 1 | | | | 19348-22032 |
| 25 | 0397107250 | HOSE ASSY | 1 | | | | 19348-52066 |
| 26 | 0397107260 | HOSE ASSY | 1 | | | | 19348-52076 |
| 27 | 0397107270 | HOSE ASSY | 1 | | | | 19348-52056 |
| 29 | 0397107290 | HOSE ASSY | 1 | | | | 19348-52050 |
| 30 | 0397107300 | HOSE ASSY | 1 | | | | 18010-52038 |
| 31 | 0397107310 | HOSE ASSY | 1 | | | | 18010-52040 |
| 32 | 0397107320 | HOSE ASSY | 1 | | | | 18010-52155 |
| 33 | 1515012040 | ELBOW | 2 | | | | |
| | 1420010110 | • O-RING | 1 | | | | |
| 34 | 1515012510 | ELBOW | 1 | | | | |
| | 1420010110 | • O-RING | 1 | | | | |
| 35 | 1515100110 | ELBOW | 1 | | | | |
| | 1420010110 | • O-RING | 1 | | | | |
| 36 | 1513300014 | ELBOW | 1 | | | | |
| | 1420010110 | • O-RING | 1 | | | | |
| 37 | 1515600200 | ADAPTOR | 4 | | | | |
| | 1420010110 | • O-RING | 1 | | | | |
| 44 | 1100041030 | BOLT | 3 | | | | |
| 45 | 1140020010 | WASHER, spring | 3 | | | | |
| 46 | 1141110010 | WASHER | 3 | | | | |
| 47 | 1130040010 | NUT | 3 | | | | |
| 48 | 1100041225 | BOLT | 3 | | | | |
| 49 | 1140020012 | WASHER, spring | 3 | | | | |
| | K3b143 | | | | | | |

ENGINE & ACCESSORIES (1/3) (14513261-14515345)

| Item | Part number | Description | Q'ty | Chan. | Serial No. | Serv. | Remarks |
|------|-------------|------------------------------------|------|-------|------------|-------|----------------|
| | | ENGINE ASSY (cab) | | | | | X03940-15000-6 |
| | | ENGINE ASSY (canopy) | | | | | X03940-16000-6 |
| | | ENGINE ASSY (with air conditioner) | | | | | X03940-16500-6 |
| | | ENGINE ASSY (for China) | | | | | X03940-17000-6 |
| 1 | 0394007100 | FOOT, engine (F.R.) | 1 | | | | |
| 2 | 0394015700 | FOOT, engine (F.L.) | 1 | | | | |
| 3 | 0394007300 | FOOT, engine (R.R.) | 1 | | | | |
| 4 | 0394007400 | FOOT, engine (R.L.) | 1 | | | | |
| 18 | 1910032047 | BAND | 2 | | | | Y23000-060000 |
| 19 | 1702430280 | CABLE, earth | 1 | | | | |
| 20 | 1651030002 | RUBBER, cushion | 4 | | | | |
| 21 | 1651030003 | RUBBER, cushion | 4 | | | | |
| 23 | 1141540012 | WASHER | 12 | | | | |
| 24 | 0003600085 | WASHER | 4 | | | | |
| 25 | 1910195001 | ENGINE (cab) | 1 | | | | 4TNNV88-QTB |
| | 1910196001 | ENGINE (canopy) | 1 | | | | 4TNNV88-QTB1 |
| 27 | 0003608252 | WASHER | 4 | | | | canopy |
| 28 | 1910195021 | PIPE, exhaust (cab) | 1 | | | | Y129642-13650 |
| | 1910196021 | PIPE, exhaust (canopy) | 1 | | | | Y129642-13660 |
| 29 | 1910195024 | PIPE | 1 | | | | Y129642-12240 |
| 40 | 1910195027 | CLAMP | 1 | | | | Y129642-13590 |
| 41 | 0394007640 | STOPPER | 2 | | | | |
| 42 | 0394007650 | STOPPER | 2 | | | | |
| 43 | 0394007660 | STOPPER | 1 | | | | |
| 44 | 0394007670 | STOPPER | 1 | | | | |
| 47 | 1100040825 | BOLT | 2 | | | | canopy |
| 48 | 1100041016 | BOLT | 1 | | | | |
| 49 | 1100041025 | BOLT | 12 | | | | |
| 50 | 1100041035 | BOLT | 4 | | | | |
| 51 | 1101141220 | BOLT | 4 | | | | |
| 52 | 1130040008 | NUT | 2 | | | | canopy |
| 53 | 1130040010 | NUT | 1 | | | | |
| 54 | 1130540012 | NUT | 8 | | | | |
| 55 | 1140020008 | WASHER, spring | 4 | | | | canopy |
| 56 | 1140020010 | WASHER, spring | 18 | | | | |
| 57 | 1141110008 | WASHER | 2 | | | | for China |
| 58 | 1140330010 | WASHER | 2 | | | | |
| 62 | 1101041240 | BOLT | 4 | | | | |
| 63 | 0394007680 | SHIM t=0.8 | AR | | | | |
| 64 | 0394007690 | SHIM t=1.6 | AR | | | | |
| 65 | 0394007700 | SHIM t=2.3 | AR | | | | |
| 68 | 1910196025 | PIPE | 1 | | | | Y129642-12210 |
| 69 | 0394016800 | FOOT, engine (F.L.) | 1 | | | | with air con. |
| 75 | 0394016010 | PLATE | 1 | | | | canopy |
| 76 | 1533201012 | U-BOLT | 1 | | | | canopy |
| 87 | 1910195047 | BAND | 1 | | | | Y23000-041000 |
| 89 | 0394016510 | PULLEY (for China) | 1 | | | | Y129155-42350 |
| 91 | 1990197054 | FILTER, fuel (for China) | 1 | | | | Y129907-55800 |
| 92 | 1990197055 | FILTER, oil (for China) | 1 | | | | Y119005-35150 |
| 93 | 0394017010 | SPACER | 1 | | | | for China |
| 94 | 1100040850 | BOLT | 2 | | | | for China |

K3c142

ENGINE & ACCESSORIES (2/2) (14515346-)

| Item | Part number | Description | Q'ty | Chan. | Serial No. | Serv. | Remarks |
|------|-------------|------------------------------------|------|-------|-------------------|-------|-------------------|
| | | ENGINE ASSY (cab) | | | | | X03940-22000-9 |
| | | ENGINE ASSY (canopy) | | | | | X03940-22500-9 |
| | | ENGINE ASSY (with air conditioner) | | | | | X03940-23000-9 |
| | | ENGINE ASSY (for China) | | | | | X03940-23500-9 |
| 5 | 0394019050 | SPONGE | 1 | | | | |
| 6 | 0394019051 | SPONGE | 1 | | | | |
| 7 | 0394019052 | SPONGE | 1 | | 14515346~14516941 | | |
| | 0394022210 | SPONGE | 1 | (H) | 14516942~14517205 | | |
| | 0394022410 | SPONGE | 1 | | 14517206~ | | |
| 8 | 0394019056 | SPONGE | 1 | | | | |
| 9 | 0394019058 | SPONGE | 1 | | 14515346~14516941 | | |
| | 0394022200 | SPONGE | 1 | (H) | 14516942~14517205 | | |
| | 0394022400 | SPONGE | 1 | | 14517206~ | | |
| 10 | 0394019055 | SPONGE | 1 | | | | |
| 11 | 0394019001 | BRACKET | 1 | | | | |
| 12 | 1420010290 | O-RING | 2 | | | | |
| 13 | 0007224015 | ADAPTOR | 2 | | | | |
| 14 | 0394019030 | HOSE | 1 | | | | |
| 15 | 0394019031 | HOSE | 1 | | | | |
| 16 | 1910006013 | BAND | 2 | | | | Y23010-038000 |
| 17 | 0394019002 | BRACKET | 1 | | | | |
| 18 | 1533001053 | BAND | 2 | | | M | |
| 22 | 0394019003 | PLATE | 2 | | | | |
| 26 | 1911300180 | RADIATOR & COOLER, oil | 1 | | 14515346~14516277 | | AKG |
| | 1911300240 | RADIATOR & COOLER, oil | 1 | | 14516278~ | | AKG |
| 26-6 | 1911300076 | · FITTING, hose | 1 | | | | |
| 26-7 | 1911300077 | · NIPPLE | 1 | | | | |
| 26-8 | 1911300078 | · CAP, radiator | 1 | | | | |
| 30 | 0394019006 | NET, wire | 1 | | | | |
| 31 | 1910047040 | TANK | 1 | | | | Y171064-44510 |
| 32 | 1910047052 | BRACKET | 1 | | | | Y121256-44600 |
| 33 | 1910047047 | BAND | 1 | | | | Y124450-44550 |
| 34 | 1651014003 | RUBBER, cushion | 2 | | | | |
| 35 | 1910078037 | VALVE | 1 | | | | Y129150-49100 |
| 36 | 1530808050 | TUBE | 1 | | | | sold by the meter |
| 37 | 1651024007 | RUBBER, cushion | 2 | | | | |
| 38 | 1531115045 | PROTECTOR | 1 | | | | sold by the meter |
| 39 | 1533120012 | BAND | 4 | | | | |
| 45 | 1100040820 | BOLT | 6 | | | | |
| 46 | 1100040816 | BOLT | 14 | | | | |
| 47 | 1100040825 | BOLT | 7 | | | | |
| 52 | 1130040008 | NUT | 6 | | | | |
| 53 | 1130040010 | BOLT | 2 | | | | |
| 55 | 1140020008 | WASHER, spring | 27 | | | | |
| 56 | 1140020010 | WASHER, spring | 4 | | | | |
| 57 | 1141110008 | WASHER | 7 | | | | |
| 59 | 1141110010 | WASHER | 4 | | | | |
| 60 | 0394019007 | PLATE | 1 | | 14515346~14516277 | | |
| 61 | 1100041030 | BOLT | 2 | | | | |
| 66 | 0394019008 | PLATE | 1 | | | | |
| 67 | 0394019010 | DUCT ASSY | 1 | | 14515346~14517205 | | |
| | 0394022300 | DUCT ASSY | 1 | | 14517206~ | | |
| 67-1 | 0394019011 | · DUCT | 1 | | 14515346~14517205 | | |
| | 0394022310 | · DUCT | 1 | | 14517206~ | | |
| 67-2 | 0394019012 | · ABSORBENT, noise | 1 | | 14515346~14517205 | | |
| | 0394026320 | · ABSORBENT, noise | 1 | | 14517206~ | | |
| 67-3 | 0394019013 | · ABSORBENT, noise | 1 | | 14515346~14517205 | | |
| | 0394022330 | · ABSORBENT, noise | 1 | | 14517206~ | | |
| 67-4 | 0394019014 | · ABSORBENT, noise | 1 | | 14515346~14517205 | | |
| | 0394022340 | · ABSORBENT, noise | 1 | | 14517206~ | | |
| 70 | 1533700041 | BAND | 4 | | | | |
| 71 | 0394019040 | HOSE | 1 | | | | |
| 72 | 0394019041 | HOSE | 1 | | | | |
| 74 | 1654601033 | TRIM | 1 | | | | sold by the meter |
| 77 | 1530808040 | TUBE | 1 | | | | sold by the meter |
| 78 | 1531115033 | PROTECTOR | 1 | | | | sold by the meter |
| 79 | 0394019061 | SHROUD ASSY | 1 | | 14515346~14516277 | | |

AIR CLEANER (for double element)

| Item | Part number | Description | Q'ty | Chan. | Serial No. | Serv. | Remarks |
|------|------------------------------------|------------------------------|------|-------|------------|-------|---|
| 1 | 1911102772 G4c150 | CLEANER ASSY, air ELEMENT | 1 | | | | X03740-07500-0 fhfif<fhf\j" P82-2858 |

ENGINE CONTROL (14510004-14513260)

| Item | Part number | Description | Q'ty | Chan. | Serial No. | Serv. | Remarks |
|------|-------------------|---|------|-------|------------|-------|------------------|
| | | CONTROL ASSY, engine | | | | | X03941-08000-3 |
| | | CONTROL ASSY, engine (with air conditioner) | | | 14512895~ | | X03941-08100-3 |
| 1 | 0374104100 | LEVER | 1 | | | | |
| 2 | 0374104200 | PLATE | 1 | | | | |
| 3 | 0394104020 | WIRE | 1 | | | | |
| 6 | 1141550018 | WASHER | 1 | | | | |
| 7 | 0007900020 | PIN | 1 | | | | |
| 8 | 0007900050 | PIN | 1 | | | | |
| 9 | 1224010006 | E-RING | 2 | | | | |
| 10 | 1225120018 | WASHER, conical | 2 | | | | |
| 11 | 1650132050 | GRIP | 1 | | | | |
| 12 | 1110040510 | SCREW, cap | 2 | | | | |
| 13 | 1100040825 | BOLT | 1 | | | | |
| 14 | 1100041020 | BOLT | 2 | | | | |
| 15 | 1130040008 | NUT | 1 | | | | |
| 16 | 1532208015 | PROTECTOR | 1 | | | | |
| 17 | 1130640018 | NUT | 1 | | | | |
| 18 | 1140020010 | WASHER, spring | 2 | | | | |
| 19 | 1652060085 | BUSHING | 1 | | | | without air con. |
| 20 | 1652231140 | BAND | 2 | | | | |
| 21 | 0334120100 | BOOT | 1 | | | | |
| 22 | 0064111700 | NUT | 1 | | | | |
| 23 | 1652060035 | BUSHING | 1 | | | | without air con. |
| | K3c042 | | | | | | |

ELECTRICAL (2/2) (14510004-14510300)

| Item | Part number | Description | Q'ty | Chan. | Serial No. | Serv. | Remarks |
|------|--------------|--------------------------|------|-------|------------|-------|-------------------|
| | | ELECTRICAL ASSY (cab) | | | | | X03942-11000-7 |
| | | ELECTRICAL ASSY (canopy) | | | | | X03942-13000-2 |
| 0-1 | X 0374205100 | UNIT, control | 1 | | | | |
| 1 | 0374205110 | • PLATE | 1 | | | | |
| 2 | 0374205140 | • COVER | 1 | | | | |
| 3 | 0374205120 | • COVER | 1 | | | | |
| 4 | 0374205150 | • RUBBER | 2 | | | | |
| 5 | 0374205130 | • RUBBER | 1 | | | | |
| 6 | 0334230120 | • RESISTOR | 2 | | | | |
| 7 | 0334230130 | • RELAY ASSY | 7 | | | | |
| 7-1 | 1711900042 | • • RELAY | 1 | | | | |
| 7-2 | 1654302003 | • • SPONGE | 1 | | | | sold by the meter |
| 8 | 0374203120 | • RESISTOR | 2 | | | | |
| 9 | 1711900062 | • RELAY | 2 | | | | |
| 10 | 1730140660 | • CONTROLER | 1 | | | | |
| 11 | 1730140680 | • BUZZER | 1 | | | | |
| 12 | 1910095116 | • UNIT, timer | 1 | | | | ,x119632-77920 |
| 13 | 1910080106 | • RELAY | 1 | | | | Y129136-77100 |
| 14 | 1653916020 | • TRIM | 1 | | | | sold by the meter |
| 15 | 1652231250 | • BAND | 4 | | | | |
| 17 | 1652711698 | • SCREW | 2 | | | | |
| 18 | 1653916020 | • SEAL | 1 | | | | sold by the meter |
| 19 | 1653916029 | • SEAL | 1 | | | | sold by the meter |
| 20 | 0007300030 | • CLAMP | 2 | | | | |
| 21 | 1730500010 | • UNIT, diode | 2 | | | | |
| 22 | 1120530310 | • SCREW | 2 | | | | |
| 23 | 1120530410 | • SCREW | 2 | | | | |
| 24 | 1100040510 | • BOLT | 8 | | | | |
| 25 | 1100040616 | • BOLT | 10 | | | | |
| 26 | 1100040610 | • BOLT | 1 | | | | |
| 29 | 1130040006 | • NUT | 15 | | | | |
| 31 | 1140020003 | • WASHER, spring | 2 | | | | |
| 32 | 1140020004 | • WASHER, spring | 2 | | | | |
| 33 | 1140020005 | • WASHER, spring | 8 | | | | |
| 34 | 1140020006 | • WASHER, spring | 26 | | | | |
| 37 | 1141110003 | • WASHER | 2 | | | | |
| 38 | 1141110004 | • WASHER | 2 | | | | |
| 39 | 1141110006 | • WASHER | 22 | | | | |
| | K3c061 | | | | | | |

WATER TEMPERATURE CONTROLLER

| Item | Part number | Description | Q'ty | Chan. | Serial No. | Serv. | Remarks |
|------|-------------------|------------------------------|------|-------|------------|-------|----------------|
| | | CONTROLLER ASSY, water temp. | | | | | X03942-24600-1 |
| 1 | 0394221700 | HARNESS ASSY, wiring | 1 | | | M | |
| 2 | 0394404130 | HARNESS ASSY, wiring | 1 | | | M | |
| 3 | 1730111520 | DRIVER, meter | 1 | | | M | |
| 4 | 1652231250 | BAND | 9 | | | M | |
| 5 | 1100040812 | BOLT | 1 | | | | |
| 6 | 1140020008 | WASHER, spring | 1 | | | | |
| 7 | 1130040008 | NUT | 1 | | | | |
| 8 | 1141110008 | WASHER | 1 | | | | |
| | K3c270 | | | | | | |

TRAVEL ALARM (14515346-)

| Item | Part number | Description | Q'ty | Chan. | Serial No. | Serv. | Remarks |
|------|-------------|----------------------|------|-------|----------------|-------|----------------|
| | | TRAVEL ALARM | | | | | X03942-22500-3 |
| 2 | 0394211530 | BRACKET | 2 | | | | |
| 3 | 0374207300 | PLATE | 2 | | | | |
| 6 | 0374207600 | HARNES, wiring | 1 | | | | |
| 6-1 | 1730500008 | · DIODE (3A, yellow) | 1 | | | | |
| 7 | 0334230130 | RELAY ASSY | 1 | | | | |
| 7-1 | 1711900042 | · RELAY | 1 | | | | |
| 7-2 | 1654302003 | · SPONGE | 1 | | | | |
| 8 | 0354211050 | BUZZER | 1 | A | 14515346~1451# | | |
| | 1703700013 | BUZZER | 1 | a(H) | 1451#~ | | No23665 |
| 9 | 0872433150 | TUBE | 6 | | | | |
| 10 | 1700009010 | SWITCH | 2 | | | | |
| 11 | 1652231250 | BAND | 5 | | | | |
| 12 | 1100040820 | BOLT | 1 | | | | |
| 13 | 1130040005 | NUT | 4 | | | | |
| 14 | 1110040610 | SCREW, cap | 4 | | | | |
| 15 | 1100040616 | BOLT | 2 | | | | |
| 16 | 1150410312 | SCREW | 4 | | | | |
| 18 | 1130030006 | NUT | 5 | | | | |
| 22 | 1140020005 | WASHER, spring | 4 | | | | |
| 23 | 1140020006 | WASHER, spring | 7 | | | | |
| 24 | 1140020008 | WASHER, spring | 1 | | | | |
| 27 | 1141110005 | WASHER | 4 | | | | |
| 28 | 1141110006 | WASHER | 5 | | | | |
| 29 | 1141110008 | WASHER | 1 | | | | |
| 30 | 0564228010 | BRACKET | 1 | a | 2006.10~ | | No23665 |
| 31 | 0003600110 | WASHER | 2 | | 2006.10~ | | |

<<NOTE>>
 "A" is interchangeable with SET
 "a".

K3c202

| RADIO | | | | | | | |
|-------|---------------------|---|------|-------|-------------------|-------|-------------------|
| Item | Part number | Description | Q'ty | Chan. | Serial No. | Serv. | Remarks |
| | | RADIO ASSY (for EC) | | | | | X03747-03000-10 |
| | | RADIO ASSY (for EC) (with air con.) | | | 14512895~ | | X03747-05100-10 |
| | | RADIO ASSY (for U.S.A.) | | | | | X03747-04000-10 |
| | | RADIO ASSY (for U.S.A.) (with air con.) | | | 14512895~ | | X03747-05200-10 |
| | | RADIO ASSY (for JAPAN) | | | | | X03747-05000-10 |
| | | RADIO ASSY (for JAPAN) (with air con.) | | | 14512895~ | | X03747-05300-10 |
| 1 | 0374703100 | COVER ASSY | 1 | | 14510004~14510138 | | |
| | 0374703200 | COVER ASSY | 1 | (H) | 14510139~ | | |
| | 0394612350 | COVER ASSY | 1 | | 14512895~ | | with air con. |
| 2 | X 0334704800 | CASSETTE STEREO ASSY | 1 | | | | for EC |
| | X 0334704300 | CASSETTE STEREO ASSY | 1 | | | | for U.S.A. |
| | X 0334704400 | CASSETTE STEREO ASSY | 1 | | | | for JAPAN |
| 2-1 | 1705004500 | • CASSETTE STEREO | 1 | | | | for EC |
| | 1705003700 | • CASSETTE STEREO | 1 | | | | for U.S.A. |
| | 1705003800 | • CASSETTE STEREO | 1 | | | | for JAPAN |
| 2-2 | 1702700002 | • SOCKET | 1 | | | | |
| 2-3 | 1702700004 | • SLEEV | 1 | | | | |
| 6 | 1705001610 | JUMPER | 1 | | 14510004~14515171 | | |
| 7 | 1652231100 | BAND | 1 | | | | for Japan, USA |
| 8 | 1652520005 | RUBBER, cushion | 4 | | | | |
| 9 | 1653917009 | TRIM | 1 | | | | sold by the meter |
| 10 | 0334704600 | BRACKET (L.H.) | 1 | | | | |
| 11 | 0334704700 | BRACKET (R.H.) | 1 | | | | |
| 12 | 1140090005 | WASHER, spring | 4 | | | | for EC |
| 14 | 1150410520 | SCREW | 4 | | | | |
| 16 | 1100090616 | BOLT | 4 | | | | |
| 17 | 1140090006 | WASHER, spring | 4 | | | | |
| 18 | 1141190006 | WASHER | 4 | | | | |
| 21 | 1120590510 | SCREW | 4 | | | | for EC |
| 22 | 1652201003 | BAND | 1 | | | | for EC |
| 23 | 1705003650 | COVER | 1 | | | | for Japan, USA |
| 24 | 1705004550 | COVER | 1 | | | | for EC |
| | K3c125 | | | | | | |

VALVE & ACCESSORIES

| Item | Part number | Description | Q'ty | Chan. | Serial No. | Serv. | Remarks |
|------|-------------|---------------------------------|------|-------|-------------------|-------|----------------|
| | | VALVE ASSY, control | | | | | X03950-08000-7 |
| | | VALVE ASSY, control (high flow) | | | | | X03950-08500-5 |
| 1 | 0007213011 | BUSHING | 11 | | 14510004~14512021 | | |
| | 0007213011 | BUSHING | 10 | | 14512022~ | | |
| 2 | 1100040825 | BOLT | 3 | | | | |
| 3 | 1140020008 | WASHER, spring | 3 | | | | |
| 4 | 1513350005 | CONNECTOR | 2 | | | | |
| | 1420010240 | • O-RING | 1 | | | | |
| 5 | 1513390027 | CROSS | 1 | | 14510004~14510009 | | |
| | 1512370010 | TEE | 1 | | 14510010~ | | |
| | 1420010110 | • O-RING | 1 | | | | |
| 6 | 1515012040 | ELBOW | 2 | | | | |
| | 1420010110 | • O-RING | 1 | | | | |
| 7 | 1515010042 | ELBOW | 17 | | | | |
| | 1420010180 | • O-RING | 1 | | | | |
| 8 | 1515010051 | ELBOW | 4 | | | | |
| | 1420010180 | • O-RING | 1 | | | | |
| 9 | 1515600200 | ADAPTOR | 8 | | | | |
| | 1420010110 | • O-RING | 1 | | | | |
| 10 | 1141110008 | WASHER | 3 | | | | |
| 11 | 1901036500 | VALVE, control | 1 | | 14510004~14514823 | | |
| | 1901043600 | VALVE, control | 1 | (H) | 14514824~ | | |
| | 1901040600 | VALVE, control (high flow) | 1 | | 14510004~14514823 | | |
| | 1901043700 | VALVE, control (high flow) | 1 | (H) | 14514824~ | | |
| 12 | 0007213010 | BUSHING | 1 | | 14512022~ | | |
| | K3d025 | | | | | | |

PIPING; UPPER (2/2) (14513261-14515345)

| Item | Part number | Description | Q'ty | Chan. | Serial No. | Serv. | Remarks |
|------|-------------------|---|------|-------|------------|-------|----------------|
| | | PIPING ASSY, upper | | | | | X03970-11000-4 |
| | | PIPING ASSY, upper (with air conditioner) | | | | | X03970-11500-4 |
| 6 | 0397007060 | VALVE ASSY, solenoid | 1 | | | | |
| | 0397007810 | VALVE ASSY, solenoid | 1 | | | | with air con. |
| 6-1 | 1901731500 | • VALVE, solenoid | 1 | | | | |
| 6-2 | 0397007061 | • CROSS | 1 | | | | |
| 6-3 | 1515012040 | • ELBOW | 3 | | | | |
| | 1515012040 | • ELBOW | 2 | | | | with air con. |
| | 1420010110 | • • O-RING | 1 | | | | |
| 6-4 | 1420010110 | • O-RING | 1 | | | | |
| 6-5 | 1512370010 | • TEE | 1 | | | | with air con. |
| | 1420010110 | • • O-RING | 1 | | | | |
| 12 | 0097022400 | GUARD | 2 | | | | |
| 14 | 1100040660 | BOLT | 2 | | | | |
| 17 | 1100040850 | BOLT | 2 | | | | |
| 18 | 1140020006 | WASHER, spring | 2 | | | | |
| 19 | 1140020008 | WASHER, spring | 2 | | | | |
| 21 | 1141110008 | WASHER | 4 | | | | |
| 27 | 1515600200 | ADAPTOR | 1 | | | | |
| | 1420010110 | • O-RING | 1 | | | | |
| 43 | 0397007430 | HOSE ASSY | 1 | | | | 18010-22100 |
| 44 | 0397007440 | HOSE ASSY | 1 | | | | 18010-22106 |
| 47 | 0397007470 | HOSE ASSY | 1 | | | | 18010-22140 |
| 48 | 0397007480 | HOSE ASSY | 1 | | | | 18010-52076 |
| 50 | 0397007500 | HOSE ASSY | 1 | | | | 18018-40400 |
| 51 | 0397007510 | HOSE ASSY | 1 | | | | 18018-40240 |
| 52 | 0397007520 | HOSE ASSY | 1 | | | | 18018-40250 |
| 53 | 0397007530 | HOSE ASSY | 1 | | | | 18018-40335 |
| 54 | 0397007540 | HOSE ASSY | 1 | | | | 18018-40335 |
| 59 | 0397007590 | HOSE ASSY | 1 | | | | 18015-20092 |
| 60 | 0397007600 | HOSE ASSY | 1 | | | | 18015-20108 |
| 61 | 0397007610 | HOSE ASSY | 1 | | | | 18015-20150 |
| 62 | 0397007620 | HOSE ASSY | 1 | | | | 18015-20175 |
| 63 | 0397007630 | HOSE ASSY | 1 | | | | 18015-40054 |
| 64 | 0397007640 | HOSE ASSY | 1 | | | | 18015-40067 |
| 65 | 0397007650 | HOSE ASSY | 1 | | | | 18015-40072 |
| 68 | 0397007680 | HOSE ASSY | 1 | | | | 18015-40072 |
| 70 | 1901721800 | VALVE, shuttle | 1 | | | | |
| 71 | 0397007690 | HOSE ASSY | 1 | | | | 18018-40400 |
| | K3d046 | | | | | | |

BOOM EMERGENCY SHUT-OFF VALVE (with pilot)

| Item | Part number | Description | Q'ty | Chan. | Serial No. | Serv. | Remarks |
|------|-------------------|---|------|-------|-------------------|-------|------------------------|
| 0 | 0395012200 | VALVE ASSY, emergency shut-off (with 3rd. aux. line) | 1 | | 14510004~14515345 | | X03950-12200-3 |
| | 0395021400 | VALVE ASSY, emergency shut-off (with 3rd. aux. line) | 1 | | 14515346~ | | X03950-21400-1 |
| | 0395012000 | VALVE ASSY, emergency shut-off (without 3rd. aux. line) | 1 | | 14510004~14515345 | | X03950-12000-3 |
| | 0395021300 | VALVE ASSY, emergency shut-off (without 3rd. aux. line) | 1 | | 14515346~ | | X03950-21300-1 |
| 1 | 0395012100 | • VALVE ASSY, emergency shut-off | 1 | | 14510004~14515345 | | |
| | 0395021310 | • VALVE ASSY, emergency shut-off | 1 | | 14515346~ | | |
| 1-1 | 1901742700 | • • VALVE, emergency shut-off | 1 | | | | |
| 1-2 | 0395009500 | • • ADAPTOR | 1 | | | | |
| 1-3 | 1513300022 | • • ELBOW | 1 | | | | |
| | 1420010110 | • • • O-RING | 1 | | | | |
| 1-4 | 1513390039 | • • ADAPTOR | 1 | | | | |
| | 1420010180 | • • • O-RING | 1 | | | | |
| 1-5 | 1515012040 | • • ELBOW | 1 | | | | |
| | 1420010110 | • • • O-RING | 1 | | | | |
| 1-6 | 1515600200 | • • ADAPTOR | 1 | | | | |
| | 1420010110 | • • • O-RING | 1 | | | | |
| 1-7 | 1515600202 | • • ADAPTOR | 1 | | | | |
| | 1420010180 | • • • O-RING | 1 | | | | |
| 1-8 | 1652231250 | • • BAND | 1 | | | | |
| 1-9 | 1700100055 | • • SWITCH, pressure | 1 | | 14510004~14515345 | | |
| | 1700100081 | • • SWITCH, pressure | 1 | | 14515346~ | | |
| 1-10 | 1700100061 | • • COVER | 1 | | | | |
| 2 | 0395009600 | • BRACKET | 1 | | | | |
| 3 | 0395009610 | • BRACKET | 1 | | | | |
| 4 | 0395009620 | • COVER | 1 | | | | |
| 5 | 0395012110 | • HOSE ASSY | 1 | | | | 18010-52380 |
| 6 | 0395012120 | • HOSE ASSY | 1 | | | | 18010-52430 |
| 7 | 0395012130 | • HARNESS, wiring | 1 | | | | |
| 8 | 0395012140 | • COVER | 1 | | | | |
| 9 | 0395012150 | • CLAMP | 2 | | | | |
| 11 | 0565017400 | • DECAL | 1 | | | | |
| 12 | 1100040616 | • BOLT | 2 | | | | |
| 13 | 1100040645 | • BOLT | 2 | | | | |
| 14 | 1100040816 | • BOLT | 1 | | | | |
| 15 | 1100040820 | • BOLT | 2 | | | | |
| 16 | 1130040006 | • NUT | 2 | | | | |
| 17 | 1140020006 | • WASHER, spring | 7 | | | | |
| 18 | 1140020008 | • WASHER, spring | 3 | | | | |
| 19 | 1141110006 | • WASHER | 8 | | | | |
| 20 | 1141110008 | • WASHER | 1 | | | | |
| 21 | 1513390015 | • TEE | 2 | | | | |
| 22 | 1533207004 | • U-BOLT | 1 | | | | |
| 23 | 1652201005 | • BAND | 5 | | | | |
| 24 | 1652201008 | • BAND | 3 | | | | |
| 25 | 1700000019 | • SWITCH, rotary | 1 | | | | |
| 26 | 1100040625 | • BOLT | 1 | | 14516492~ | | |
| 27 | 1700550024 | • ORNAMENT | 1 | | | | without 3rd. aux. line |
| 28 | 0395021330 | • BRACKET | 1 | | 14515346~ | | |
| 29 | 1711900042 | • RELAY | 2 | | 14515346~ | | |
| 30 | 1652231250 | • BAND | 1 | | 14515346~ | | |
| 31 | 0395021320 | • HARNESS, wiring | 1 | | 14515346~ | | |
| 32 | 1700100038 | • COVER | 2 | | 14516492~ | | |

K3d143

HYDRAULIC TANK (14513261-)

| Item | Part number | Description | Q'ty | Chan. | Serial No. | Serv. | Remarks |
|-------|-------------------|----------------------|------|-------|-------------------|-------|-------------------|
| | | TANK ASSY, hydraulic | | | | | X03980-08700-2 |
| 1 | 0398008100 | TANK, hydraulic | 1 | | 14513261~14515345 | | |
| | 0398008800 | TANK, hydraulic | 1 | | 14515346~ | | |
| 2 | 0398004300 | PIPE | 1 | | | | |
| 3 | 0398008310 | NIPPLE | 1 | | 14513261~14515345 | | |
| | 0398008710 | NIPPLE ASSY | 1 | | 14515346~ | | |
| 3-1 | 0398008720 | • PIPE | 1 | | 14515346~ | | |
| 3-2 | 1540141230 | • VALVE, check | 1 | | 14515346~ | | |
| 3-3 | 0397011140 | • ADAPTOR | 1 | | 14515346~ | | |
| 3-3-3 | 1420010110 | • • O-RING | 1 | | 14515346~ | | |
| 4 | 0378004320 | COVER | 1 | | | | |
| 5 | 0378004340 | PLATE | 1 | | | | |
| 6 | 0373504320 | RUBBER | 1 | | | | |
| 8 | 1553020685 | GAUGE | 1 | | | | |
| 9 | 0007000031 | SPRING | 1 | | | | |
| 10 | 1551102600 | ELEMENT | 1 | | | | |
| 11 | 1551100300 | VALVE ASSY | 1 | | | | |
| 12 | 1550020150 | FILTER | 1 | | | | |
| 13 | 1515012040 | ELBOW | 4 | | | | |
| | 1420010110 | • O-RING | 1 | | | | |
| 14 | 1515010041 | ELBOW | 1 | | | | |
| | 1420010140 | • O-RING | 1 | | | | |
| 15 | 1420010290 | O-RING | 3 | | | | |
| 16 | 1420101250 | O-RING | 1 | | | | |
| 17 | 1420101450 | O-RING | 1 | | | | |
| 18 | 0007256006 | PLUG | 3 | | | | |
| 19 | 1654302008 | SPONGE | 1 | | | | |
| 20 | 1653917004 | TRIM | 1 | | | M | sold by the meter |
| 21 | 1100041025 | BOLT | 2 | | | | |
| 22 | 1100040820 | BOLT | 2 | | | | |
| 23 | 1100041016 | BOLT | 10 | | | | |
| 24 | 1100041035 | BOLT | 2 | | | | |
| 25 | 1140020008 | WASHER, spring | 2 | | | | |
| 26 | 1140020010 | WASHER, spring | 10 | | | | |
| 27 | 1141110008 | WASHER | 2 | | | | |
| 28 | 1141110010 | WASHER | 10 | | | | |
| 29 | 1141550010 | WASHER | 4 | | | | |
| 31 | 0003900061 | SPACER | AR | | | M | t=1.2mm |
| 32 | 0003900062 | SPACER | AR | | | M | t=2.0mm |
| 33 | 0003900063 | SPACER | AR | | | M | t=3.2mm |
| 34 | 1653917006 | TRIM | 1 | | | M | sold by the meter |
| | K3d075 | | | | | | |

FUEL TANK & FUEL PIPING (for HE-SERVICE; 14513261-)

| Item | Part number | Description | Q'ty | Chan. | Serial No. | Serv. | Remarks |
|------|-------------|------------------|------|-------|------------|-------|-------------------|
| | | TANK ASSY, fuel | | | | | X03981-12500-6 |
| 1 | 0398109100 | TANK | 1 | | | | |
| 3 | 0398105200 | NIPPLE | 1 | | | | |
| 5 | 0007300050 | CLAMP | 3 | | | | |
| 6 | 0007300055 | CLAMP | 1 | | | | |
| 7 | 1552100500 | CAP | 1 | | | | |
| 8 | 1552100320 | STRAINER | 1 | | | | |
| 9 | 1522100014 | COCK | 1 | | | | |
| 10 | 1553201900 | SENDER, fuel | 1 | | | | |
| 10-1 | 1553201918 | • PACKING | 1 | | | | |
| 11 | 0007300019 | CLAMP | 2 | | | | |
| 12 | 1652231140 | BAND | 4 | | | | |
| 13 | 1552001200 | SEPARATOR, water | 1 | | | | |
| 14 | 1910199034 | PUMP, feed | 1 | | | | Y129612-52100 |
| 16 | 1531007011 | HOSE | 2 | | | | sold by the meter |
| 17 | 1531207025 | HOSE | 1 | | | | sold by the meter |
| 18 | 1531207053 | HOSE | 1 | | | | sold by the meter |
| 19 | 1531207270 | HOSE | 1 | | | | sold by the meter |
| 20 | 1531207302 | HOSE | 1 | | | | sold by the meter |
| 21 | 1531010046 | HOSE | 1 | | | | sold by the meter |
| 22 | 1531010102 | HOSE | 1 | | | | sold by the meter |
| 23 | 1531115012 | PROTECTOR | 1 | | | | sold by the meter |
| 24 | 1531115020 | PROTECTOR | 1 | | | | sold by the meter |
| 25 | 1531115082 | PROTECTOR | 1 | | | | sold by the meter |
| 26 | 1531115099 | PROTECTOR | 1 | | | | sold by the meter |
| 27 | 1533120511 | BAND | 8 | | | | |
| 28 | 1533120015 | BAND | 1 | | | | |
| 29 | 1533700015 | BAND | 2 | | | | |
| 30 | 1553000001 | FLOAT | 1 | | | | |
| 31 | 1150110510 | SCREW | 5 | | | | |
| 32 | 1100040616 | BOLT | 2 | | | | |
| 33 | 1100040816 | BOLT | 2 | | | | |
| 36 | 1100041020 | BOLT | 1 | | | | |
| 37 | 1100041025 | BOLT | 8 | | | | |
| 38 | 1130040008 | NUT | 3 | | | | |
| 39 | 1140020006 | WASHER, spring | 2 | | | | |
| 40 | 1140020008 | WASHER, spring | 5 | | | | |
| 41 | 1140020010 | WASHER, spring | 3 | | | | |
| 43 | 1141110006 | WASHER | 2 | | | | |
| 45 | 1141550010 | WASHER | 5 | | | | |
| 46 | 0003600025 | WASHER | 1 | | | | |
| 47 | 1501750010 | PLUG | 1 | | 14514410~ | | |
| | 1420010290 | • O-RING | 1 | | 14514410~ | | |
| | K3d116 | | | | | | |

COVER (1/3) (14515346-)

| Item | Part number | Description | Q'ty | Chan. | Serial No. | Serv. | Remarks |
|------|-------------|-------------------------|------|-------|-------------------|-------|-------------------|
| | | COVER ASSY (cab) | | | | | X03982-20000-4 |
| | | COVER ASSY (canopy) | | | | | X03982-20500-4 |
| 1 | 0398213500 | HOOD, engine (cab) | 1 | | 14515346~14516277 | | see page (2/3) |
| | 0398212500 | HOOD, engine (cab) | 1 | (H) | 14516278~ | | see page (2/3) |
| | 0398213600 | HOOD, engine (canopy) | 1 | | 14515346~14516277 | | see page (2/3) |
| | 0398207500 | HOOD, engine (canopy) | 1 | (H) | 14516278~ | | see page (2/3) |
| 2 | 0398212200 | COVER, front | 1 | | | | see page (3/3) |
| 3 | 0398205300 | COVER ASSY, side (L.H.) | 1 | | | | |
| 3-1 | 0398206200 | · COVER, side (L.H.) | 1 | | | | |
| 3-2 | 0398205310 | · ABSORBENT, noise | 1 | | | | |
| 3-3 | 1654307049 | · SPONGE | 1 | | | | sold by the meter |
| 4 | 0398213230 | COVER ASSY, side (R.H.) | 1 | | | | |
| 4-1 | 0398213240 | · COVER (R.H.) | 1 | | | | |
| 4-2 | 0398205510 | · ABSORBENT, noise | 1 | | | | |
| 4-3 | 0398213250 | · NET | 1 | | | | |
| 4-4 | 0398213251 | · NET | 1 | | | | |
| 4-5 | 1130040006 | · NUT | 13 | | | | |
| 4-6 | 1140020006 | · WASHER, spring | 13 | | | | |
| 4-7 | 1141110006 | · WASHER | 13 | | | | |
| 4-8 | 0003600090 | · WASHER | 13 | | | | |
| 5 | 0398205700 | COVER, front | 1 | | | | |
| 6 | 0398205800 | COVER ASSY, center | 1 | | | | |
| 6-1 | 0398205810 | · COVER | 1 | | | | |
| 6-2 | 0398205801 | · ABSORBENT, noise | 1 | | | | |
| 6-3 | 1654606104 | · SEAL | 1 | | | | sold by the meter |
| 6-4 | 1654307048 | · SPONGE | 1 | | | | sold by the meter |
| 7 | 0398213210 | COVER | 1 | | | | |
| 8 | 0398205920 | BOX | 1 | | | | |
| 9 | 0398205930 | BRACKET | 1 | | | | |
| 10 | 0378207560 | BRACKET | 1 | | | | |
| 11 | 0378206940 | BRACKET | 1 | | | | |
| 12 | 0378206950 | PIN | 2 | | | | |
| 13 | 0358202400 | SHEET | 3 | | | | |
| 14 | 0398200800 | COLLAR | 2 | | | | |
| 15 | 0138255300 | BOLT | 4 | | | | |
| 17 | 1100040820 | BOLT | 8 | | | | |
| 18 | 1100040830 | BOLT | 6 | | | | |
| 19 | 1654619048 | TRIM | 1 | | | | sold by the meter |
| 20 | 1100041020 | BOLT | 10 | | | | |
| 21 | 1100041025 | BOLT | 3 | | | | |
| 22 | 1100041030 | BOLT | 4 | | | | |
| 23 | 1140020008 | WASHER, spring | 18 | | | | |
| 24 | 1140020010 | WASHER, spring | 17 | | | | |
| 25 | 1141110008 | WASHER | 8 | | | | |
| 26 | 1141110010 | WASHER | 10 | | | | |
| 27 | 0003608252 | WASHER | 12 | | | | |
| 28 | 0003600025 | WASHER | 7 | | | | |
| 29 | 1130040008 | NUT | 4 | | | | |
| 30 | 1120590412 | SCREW | 2 | | | | |
| 31 | 1652102410 | RUBBER | 2 | | | | |
| 32 | 1929900237 | ROPE | 1 | | | | |
| 33 | 1653900037 | DAMPER | 2 | | 14515346~14517433 | | |
| | 1653900068 | DAMPER | 2 | (H) | 14517434~ | M | |
| 34 | 0003900028 | SPACER | AR | | | | t=4.5 |
| 35 | 0003900027 | SPACER | AR | | | | t=2.3 |
| 36 | 0358212034 | RUBBER | AR | | | | |
| 37 | 1100040825 | BOLT | 6 | | | | |

K3e424

FLOOR FRAME

| Item | Part number | Description | Q'ty | Chan. | Serial No. | Serv. | Remarks |
|------|-------------|--|------|---------|-------------------|-------|--------------------|
| | | FLOOR ASSY (cab) | | | | | X03935-19000-12 |
| | | FLOOR ASSY (cab) (with 3rd aux. line) | | | | | X03935-19200-12 |
| | | FLOOR ASSY (canopy) | | | | | X03935-20000-12 |
| | | FLOOR ASSY (canopy) (with 3rd aux. line) | | | | | X03935-19300-12 |
| | | FLOOR ASSY (with air conditioner) | | | 14512895~ | | X03935-19100-12 |
| 1 | 0373504100 | FRAME (canopy) | 1 | A | 14510004~14510390 | | |
| | 0373504600 | FRAME (canopy) | 1 | a(H) | 14510391~14511578 | | |
| | 0373507100 | FRAME (canopy) | 1 | C | 14511579~14511835 | | |
| | 0373508100 | FRAME (canopy) | 1 | c(H) | 14511836~ | | |
| | 0373504500 | FRAME (cab) | 1 | B | 14510004~14510390 | | |
| | 0373504700 | FRAME (cab) | 1 | b(H) | 14510391~14511578 | | |
| | 0373507200 | FRAME (cab) | 1 | D | 14511579~14511835 | | |
| | 0373507500 | FRAME (cab) | 1 | d(H) | 14511836~ | | |
| 2 | 0373504200 | PLATE | 1 | | 14510004~14510530 | | |
| | 0373504800 | PLATE | 1 | | 14510531~14511578 | | |
| | 0373507300 | PLATE | 1 | | 14511579~ | | |
| | 0397311400 | PLATE | 1 | | | | with 3rd aux. line |
| | 0394612400 | PLATE | 1 | | 14512895~ | | with air con. |
| 3 | 0373504300 | HINGE | 2 | | | | |
| 4 | 0373504370 | SHAFT | 2 | | | | |
| 5 | 0373504350 | ROD | 1 | | | | |
| 7 | 0343500800 | BOLT | 1 | C,D | 14510004~14511835 | | |
| | 0373507007 | BOLT | 1 | c,d(H) | 14511836~ | | |
| 8 | 0343500900 | PLATE | 1 | | | | |
| 9 | 0343503200 | PIN | 4 | | | | cab |
| | 0343503200 | PIN | 3 | | | | canopy |
| 10 | 0373502600 | SPACER | 4 | | | | |
| 11 | 0343501200 | SPACER | 2 | | | | |
| 12 | 0373504360 | SPACER | 4 | | | | |
| 13 | 0373502900 | SPACER | 4 | | | | |
| 14 | 0343501400 | CUSHION | 6 | | | | |
| 15 | 0373502990 | CUSHION | 4 | | 14510004~14513179 | | |
| | 0373502995 | CUSHION | 4 | | 14513180~ | | |
| 16 | 0343501600 | PLATE | 5 | | | | |
| 17 | 0343501700 | PLATE | 2 | | 14510004~14513179 | | |
| | 0373504510 | PLATE | 2 | | 14513180~ | | |
| 18 | 0373504380 | STOPPER | 2 | | | | |
| 19 | 0433503100 | RUBBER | 8 | | | | |
| 20 | 0433503200 | COVER | 8 | | | | |
| 21 | 0393504150 | HOOK | 2 | A, B | 14510004~14510390 | | |
| | 0393514100 | HOOK | 2 | a, b(H) | 14510391~ | | |
| 22 | 0393501000 | COLLAR | 2 | | | | |
| 23 | 0373504450 | LOCK | 2 | | | | |
| 24 | 0004010025 | PIN | 4 | | | | cab |
| | 0004010025 | PIN | 3 | | | | canopy |
| 25 | 0007000029 | SPRING | 1 | | | | |
| 26 | 1100040612 | BOLT | 2 | | | | |
| 27 | 1100040640 | BOLT | 1 | | | | |
| 28 | 1100040816 | BOLT | 6 | | | | |
| 29 | 1100040830 | BOLT | 4 | | | | |
| 30 | 1100041030 | BOLT | 4 | | | | |
| 31 | 1100041040 | BOLT | 2 | | | | |
| 32 | 1100141605 | BOLT | 4 | | | | |
| 33 | 1110040820 | BOLT | 2 | | | | |
| 34 | 1111041265 | SCREW, cap | 4 | | | | |
| 35 | 1130040006 | NUT | 2 | | | | |
| 36 | 1130140010 | NUT | 8 | A, B | 14510004~14510390 | | |
| | 1130040010 | NUT | 8 | a, b(H) | 14510391~ | | |
| 37 | 1130040016 | NUT | 4 | | | | |
| 38 | 1140020008 | WASHER, spring | 10 | | | | |
| 39 | 1140020010 | WASHER, spring | 6 | | | | |
| 40 | 1140020016 | WASHER, spring | 4 | | | | |
| 41 | 1141110008 | WASHER | 6 | | | | |
| 42 | 1141110010 | WASHER | 8 | | | | cab |
| | 1141110010 | WASHER | 6 | | | | canopy |

| SEAT (1/2) | | | | | | |
|------------|---------------|-------------------|------|-------|------------|-------------------|
| Item | Part number | Description | Q'ty | Chan. | Serial No. | Serv. Remarks |
| 0 | 1914100071 | SEAT (fabric) | 1 | | | |
| | 1914100072 | SEAT (PVC) | 1 | | | |
| 1 | 1914101072 | · RAIL ASSY | 1 | | | |
| 2 | 1914102072 | · PLATE ASSY | 1 | | | |
| 3 | 1914103071 | · BOOT | 1 | | | fabric |
| | 1914103072 | · BOOT | 1 | | | PVC |
| 4 | 1914104072 | · ANGLE ASSY | 1 | | | |
| 5 | 1914105072 | · LINK ASSY | 1 | | | |
| 6 | 1914106072 | · DAMPER ASSY | 1 | | | |
| 7 | 1914107072 | · SPRING ASSY | 1 | | | |
| 8 | 1914108072 | · TRIM | 1 | | | PVC |
| | 1914101071 | · TRIM | 1 | | | fabric |
| 9 | 1914109072 | · TRIM | 1 | | | PVC |
| | 1914102071 | · TRIM | 1 | | | fabric |
| 10 | 1914110072 | · RAIL ASSY | 1 | | | |
| 11 | 1914111072 | · BOLT ASSY | 1 | | | |
| 12 | 1914112072 | · COVER (L.H.) | 1 | | | |
| 13 | 1914113072 | · FRAME | 1 | | | |
| 14 | 1914114072 | · COVER (R.H.) | 1 | | | |
| 15 | 1914115072 | · FRAME | 1 | | | |
| 16 | 1914116072 | · GUIDE | 2 | | | for USA,Canada,EC |
| 17 | 1914117072 | · BRACKET | 1 | | | for USA,Canada,EC |
| 18 | 1914118072 | · JOINT ASSY | 1 | | | |
| 19 | 1914119072 | · PLATE | 1 | | | |
| 20 | 1914120072 | · SCREW, cap | 1 | | | |
| 21 | 1914121072 | · PLATE | 1 | | | |
| 22 | 1914122072 | · PLUG | 2 | | | for USA,Canada,EC |
| 23 | 1914123072 | · BELT ASSY, seat | 1 | | | |
| | G4e181 | | | | | |

CAB (3/4) (front sash; 14510004-14513260)

| Item | Part number | Description | Q'ty | Chan. | Serial No. | Serv. | Remarks |
|------|-------------------|------------------|------|-------|------------|-------|---------|
| 0-1 | 0338630400 | SASH ASSY, front | 1 | | | | |
| 1 | 0338630430 | ▪ SASH, front | 1 | | | | |
| 2 | 0568639330 | ▪ GLASS | 1 | | | | |
| 3 | 0568621800 | ▪ SEAL | 1 | | | | |
| 4 | 0568621900 | ▪ PLATE | 1 | | | | |
| 5 | 0568622200 | ▪ ROLLER | 4 | | | | |
| 6 | 0568622400 | ▪ PLATE (L.H.) | 1 | | | | |
| 7 | 0568622300 | ▪ PLATE | 1 | | | | |
| 8 | 0468605031 | ▪ SHIM t=0.7 | AR | | | | |
| 9 | 0468605032 | ▪ SHIM t=1.2 | AR | | | | |
| 10 | 0468605033 | ▪ SHIM t=1.6 | AR | | | | |
| 11 | 0398612500 | ▪ COVER | 2 | | | | |
| 13 | 0338630440 | ▪ PLATE | 1 | | | | |
| 15 | 1654005350 | ▪ LATCH (L.H.) | 1 | | | | |
| 16 | 1654005300 | ▪ LATCH (R.H.) | 1 | | | | |
| 17 | 1704078912 | ▪ MOTOR, wiper | 1 | | | | |
| 18 | 1704100530 | ▪ ARM, wiper | 1 | | | | |
| 19 | 1704200530 | ▪ BLADE | 1 | | | | |
| 21 | 1654616080 | ▪ DAM | 2 | | | | |
| 22 | 1654615085 | ▪ DAM | 2 | | | | |
| 25 | 1100290820 | ▪ BOLT | 2 | | | | |
| 26 | 1110090516 | ▪ SCREW, cap | 12 | | | | |
| 28 | 1122510412 | ▪ SCREW | 6 | | | | |
| 29 | 1120590408 | ▪ SCREW | 2 | | | | |
| 31 | 1120590516 | ▪ SCREW | 3 | | | | |
| 32 | 1140090005 | ▪ WASHER, spring | 3 | | | | |
| 34 | 1140090004 | ▪ WASHER, spring | 2 | | | | |
| 36 | 1141190008 | ▪ WASHER | 2 | | | | |
| | G4e112 | | | | | | |

CAB (1/4) (14513261-)

| Item | Part number | Description | Q'ty | Chan. | Serial No. | Serv. | Remarks |
|------|-------------|--------------------|------|-------|------------|-------|-------------------|
| 0 | X ***** | CAB ASSY | 1 | | | | X03786-04000-6 |
| | 0378604300 | CAB ASSY | 1 | | | | X03786-04300-6 |
| 1 | X ***** | • CAB | 1 | | | | |
| 2 | 0338630400 | • SASH, front | 1 | | | | see page (3/4) |
| 3 | 0568629200 | • DOOR | 1 | | | | see page (4/4) |
| 4 | 0378601300 | • SASH ASSY | 1 | | | | |
| 4-2 | 0378601320 | • • GLASS | 1 | | | | |
| 4-3 | 0378601330 | • • GLASS | 1 | | | | |
| 4-8 | 0338630650 | • • LOCK ASSY | 2 | | | | |
| 5 | 0378601600 | • GLASS, front | 1 | | | | |
| 5-1 | 0378601610 | • • GLASS | 1 | | | | |
| 5-2 | 1654010900 | • • RETAINER | 2 | | | | |
| 5-3 | 1654011100 | • • PACKING | 4 | | | | |
| 5-4 | 1654011000 | • • PLATE | 2 | | | | |
| 5-5 | 1122410412 | • • SCREW | 4 | | | | |
| 6 | 0568639530 | • GLASS | 1 | | | | |
| 7 | 0378601400 | • GLASS | 1 | | | | |
| 8 | 0378601900 | • GLASS | 1 | | | | |
| 9 | 0358605300 | • GLASS | 1 | | | | |
| 15 | 0378601450 | • ABSORBENT, noise | 1 | | | | |
| 16 | 0378601460 | • ABSORBENT, noise | 1 | | | | |
| 17 | 0378601470 | • ABSORBENT, noise | 1 | | | | |
| 27 | 0438601770 | • SPACER | 7 | | | | |
| 29 | 0568634100 | • SEAL | 1 | | | | |
| 31 | 0568626600 | • GROMMET | 1 | | | | |
| 35 | 0378601500 | • ABSORBENT, noise | 1 | | | | |
| 40 | 1653303010 | • CAP | 3 | | | | |
| 46 | 1651101042 | • RUBBER | 2 | | | | |
| 51 | 1654606090 | • SEAL | 1 | | | | sold by the meter |
| 52 | 1654619203 | • SEAL | 1 | | | | sold by the meter |
| 54 | 1653930355 | • RUBBER | 1 | | | | sold by the meter |
| 55 | 1654605341 | • RUBBER | 1 | | | | sold by the meter |
| 56 | 1654605374 | • RUBBER | 1 | | | | sold by the meter |
| 57 | 1654605033 | • RUBBER | 2 | | | | sold by the meter |
| 58 | 1654262150 | • H-RUBBER | 1 | | | | sold by the meter |
| 59 | 1654615216 | • H-RUBBER | 1 | | | | sold by the meter |
| 60 | 1654231336 | • H-RUBBER | 1 | | | | sold by the meter |
| 61 | 1654615296 | • DAM | 1 | | | | sold by the meter |
| 64 | 1653916222 | • TRIM | 1 | | | | sold by the meter |
| 65 | 1100090820 | • BOLT | 6 | | | | |
| 74 | 1654312090 | • SPONGE | 1 | | | | sold by the meter |
| 79 | 1140090008 | • WASHER, spring | 6 | | | | |
| 80 | 1654312030 | • SPONGE | 2 | | | | sold by the meter |
| 84 | 1141190010 | • WASHER | 2 | | | | |
| 88 | 1130090010 | • NUT | 2 | | | | |
| 89 | 0394608010 | • ABSORBENT, noise | 1 | | | | with air con. |
| 90 | 0394608011 | • ABSORBENT, noise | 1 | | | | with air con. |
| 91 | 0394608012 | • ABSORBENT, noise | 1 | | | | with air con. |
| 114 | 0378603310 | • URETHANE | 1 | | | | |
| 115 | 0378603311 | • URETHANE | 1 | | | | |
| 116 | 0378603312 | • URETHANE | 1 | | | | |
| 117 | 0378603313 | • URETHANE | 1 | | | | |
| 118 | 1654318050 | • SPONGE | 1 | | | | sold by the meter |
| | G4e098 | | | | | | |

OUT SIDE REARVIEW MIRROR

| Item | Part number | Description | Q'ty | Chan. | Serial No. | Serv. | Remarks |
|------|------------------------------------|-----------------------|------|-------|------------|-------|----------------|
| 1 | 1656500610 G4e141 | MIRROR ASSY MIRROR | 1 | | | | X03787-00000-0 |

HEATER (canopy; 14513261-)

| Item | Part number | Description | Qty | Chan. | Serial No. | Serv. | Remarks |
|------|-------------------|----------------------|-----|-------|------------|-------|-------------------|
| | | HEATER ASSY | | | | | X03945-13200-1 |
| 3 | 0374507010 | HARNES, wiring | 1 | | | | |
| 3-1 | 1730500008 | • DIODE (3A, yellow) | 3 | | | | |
| 4 | 0374505400 | COVER | 1 | | | | |
| 8 | 0374504530 | SPONGE | 1 | | | | |
| 10 | 0097210300 | GUARD | 1 | | | | |
| 11 | 1700000011 | SWITCH, heater | 1 | | | | |
| 12 | 1654307023 | SPONGE | 2 | | | | |
| 13 | 1654307014 | SPONGE | 2 | | | | |
| 14 | 1911508100 | HEATER | 1 | | | | |
| 15 | 1911502200 | NIPPLE | 1 | | | | |
| 16 | 1911502100 | VALVE | 1 | | | | |
| 17 | 1911500500 | CLAMP | 4 | | | | |
| 18 | 1911541845 | HOSE | 2 | | | | sold by the meter |
| 19 | 1531345100 | PROTECTOR | 1 | | | | sold by the meter |
| 21 | 1652052600 | GROMMET | 1 | | | | |
| 23 | 1100041020 | BOLT | 4 | | | | |
| 24 | 1110040820 | SCREW, cap | 2 | | | | |
| 27 | 1140020010 | WASHER, spring | 5 | | | | |
| 28 | 1140020008 | WASHER, spring | 4 | | | | |
| 31 | 1141110010 | WASHER | 4 | | | | |
| 32 | 1141110008 | WASHER | 4 | | | | |
| 37 | 1531345050 | PROTECTOR | 2 | | | | sold by the meter |
| 38 | 1652231250 | BAND | 12 | | | | |
| 39 | 0007210029 | BUSHING | 1 | | | | |
| 40 | 1100241040 | BOLT | 1 | | | | |
| 41 | 1130040010 | NUT | 2 | | | | |
| 42 | 1531345020 | PROTECTOR | 1 | | | | sold by the meter |
| 43 | 0007300030 | CLAMP | 1 | | | | |
| 44 | 0007300065 | CLAMP | 2 | | 14517452~ | M | |
| 45 | 1100040816 | BOLT | 1 | | 14517452~ | | |
| 46 | 1130040008 | NUT | 1 | | 14517452~ | | |
| | K3e381 | | | | | | |

AIR CONDITIONER (3/7) (14510004-14511994)

| Item | Part number | Description | Q'ty | Chan. | Serial No. | Serv. | Remarks |
|------|---------------|-----------------------|------|-------|------------|-------|----------------|
| | | CONDITIONER ASSY, air | | | | | X03946-03000-1 |
| 0-2 | X 0394605000 | CONDENSER ASSY | 1 | | | | |
| 1 | 0394605100 | · COVER | 1 | | | | |
| 3 | 0394600800 | · BRACKET (L.H.) | 1 | | | | |
| 4 | 0394600900 | · BRACKET (R.H.) | 1 | | | | |
| 5 | 1911504680 | · CONDENSER | 1 | | | | |
| 6 | 1911504690 | · DRYER | 1 | | | | |
| 7 | 1652241400 | · BAND | 2 | | | | |
| 10 | 1100040616 | · BOLT | 6 | | | | |
| 11 | 1100040816 | · BOLT | 4 | | | | |
| 12 | 1140020006 | · WASHER, spring | 6 | | | | |
| 13 | 1140020008 | · WASHER, spring | 4 | | | | |
| 14 | 1141110006 | · WASHER | 6 | | | | |
| 15 | 1141110008 | · WASHER | 4 | | | | |
| | K3e130 | | | | | | |

AIR CONDITIONER (1/8) (14511995-14512894)

| Item | Part number | Description | Q'ty | Chan. | Serial No. | Serv. | Remarks |
|------|---------------|----------------------------|------|-------|------------|-------|-------------------|
| | | CONDITIONER ASSY, air | | | | | X03946-10000-0 |
| 1 | X 0394609000 | COMPRESSOR ASSY | 1 | | | | see page (2/8) |
| 2 | X 0394605000 | CONDENSER ASSY | 1 | | | | see page (3/8) |
| 3 | X 0394608000 | UNIT ASSY, air conditioner | 1 | | | | see page (4/8) |
| 4 | X 0394607000 | UNIT, heater | 1 | | | | see page (8/8) |
| 5 | 0394603010 | HOSE ASSY | 1 | | | | |
| 5-1 | 1532212235 | · PROTECTOR | 1 | | | | sold by the meter |
| 6 | 0394603020 | HOSE ASSY | 1 | | | | |
| 6-1 | 1532208260 | · PROTECTOR | 1 | | | | sold by the meter |
| 7 | 0394603030 | HOSE ASSY | 1 | | | | |
| 7-1 | 1532208018 | · PROTECTOR | 1 | | | | sold by the meter |
| 8 | 0394603040 | HOSE ASSY | 1 | | | | |
| 8-1 | 1532210165 | · PROTECTOR | 1 | | | | sold by the meter |
| 9 | 0872463100 | GAS, coolant | 4 | | | | |
| | K3e111 | | | | | | |

AIR CONDITIONER (6/8) (14511995-14512894)

| Item | Part number | Description | Q'ty | Chan. | Serial No. | Serv. | Remarks |
|-------|--------------|----------------------------|------|-------|------------|-------|----------------|
| | | CONDITIONER ASSY, air | | | | | X03946-10000-0 |
| 0-3 | X 0394608000 | UNIT ASSY, air conditioner | 1 | | | | X03946-08000-1 |
| 0-3-5 | X ***** | · CONTROL ASSY | 1 | | | | X03946-08300-0 |
| 1 | 0394606560 | · · COVER | 1 | | | | |
| 2 | 0394606570 | · · PLATE | 1 | | | | |
| 3 | 0394608310 | · · HARNESS, wiring | 1 | | | | |
| 3-1 | 1730500008 | · · · DIODE (3A yellow) | 2 | | | | |
| 4 | 0394606540 | · · WIRE | 1 | | | | |
| 5 | 1911504501 | · · THERMOSTAT | 1 | | | | |
| 6 | 1911504510 | · · SWITCH | 1 | | | | |
| 7 | 0334230130 | · · RELAY ASSY | 2 | | | | |
| 7-1 | 1711900042 | · · · RELAY | 1 | | | | |
| 7-2 | 1654302003 | · · · SPONGE | 1 | | | | |
| 8 | 0394606550 | · · DECAL | 1 | | | | |
| 9 | 0564612520 | · · LEVER | 1 | | | | |
| 10 | 0564612530 | · · CLAMP | 1 | | | | |
| 11 | 0564612550 | · · KNOB | 1 | | | | |
| 12 | 1100040516 | · · BOLT | 1 | | | | |
| 14 | 1120530310 | · · SCREW | 1 | | | | |
| 15 | 1120530408 | · · SCREW | 1 | | | | |
| 16 | 1120530510 | · · SCREW | 6 | | | | |
| 17 | 1130040005 | · · NUT | 4 | | | | |
| 18 | 1130040006 | · · NUT | 2 | | | | |
| 19 | 1140020004 | · · WASHER, spring | 2 | | | | |
| 20 | 1140020005 | · · WASHER, spring | 6 | | | | |
| 21 | 1140020006 | · · WASHER, spring | 2 | | | | |
| 22 | 1141110005 | · · WASHER | 1 | | | | |
| 23 | 1141110006 | · · WASHER | 2 | | | | |
| 24 | 0568800400 | · · DIODE | 1 | | | | |
| 25 | 1120530420 | · · SCREW | 1 | | | | |
| 26 | 1130040003 | · · NUT | 1 | | | | |
| 27 | 1140020003 | · · WASHER, spring | 1 | | | | |
| 28 | 0394608320 | · · SPONGE | 1 | | | | |
| | K3e161 | | | | | | |

AIR CONDITIONER (3/6) (14512895-14513260)

| Item | Part number | Description | Q'ty | Chan. | Serial No. | Serv. | Remarks |
|------|---------------|----------------------------|------|-------|------------|-------|-------------------|
| | | CONDITIONER ASSY, air | | | | | X03946-12000-0 |
| 0 | X 0394612300 | UNIT ASSY, air conditioner | 1 | | | | X03946-12300-5 |
| 3 | 0394608013 | ▪ URETHANE | 1 | | | | |
| 5 | 0394612422 | ▪ URETHANE | 1 | | | | |
| 8 | 1911505723 | ▪ LOUVER | 2 | | | | |
| 12 | 1100040616 | ▪ BOLT | 2 | | | | |
| 15 | 1140020006 | ▪ WASHER, spring | 2 | | | | |
| 18 | 1141110006 | ▪ WASHER | 2 | | | | |
| 20 | 1654319015 | ▪ SPONGE | 1 | | | | sold by the meter |
| 26 | 1652060085 | ▪ BUSHING | 1 | | | | |
| 27 | 1652060051 | ▪ BUSHING | 1 | | | | |
| 28 | 1653916008 | ▪ TRIM | 1 | | | | sold by the meter |
| 31 | 1653916039 | ▪ TRIM | 1 | | | | sold by the meter |
| 33 | 0394612370 | ▪ COVER | 1 | | | | |
| 34 | 1652060038 | ▪ BUSHING | 1 | | | | |
| 35 | 1654601010 | ▪ TRIM | 1 | | | | sold by the meter |
| | K3e241 | | | | | | |

AIR CONDITIONER (2/6) (14513261-14515345)

| Item | Part number | Description | Q'ty | Chan. | Serial No. | Serv. | Remarks |
|------|---------------|-----------------------|------|-------|------------|-------|----------------|
| | | CONDITIONER ASSY, air | | | | | X03946-14500-1 |
| 0 | X 0394614600 | CONDENSER ASSY | 1 | | | | X03946-14600-4 |
| 1 | 1911505514 | ▪ SWITCH, presser | 1 | | | | |
| 2 | 1911505503 | ▪ CONDENSER | 1 | | | | |
| 3 | 1911505511 | ▪ DRYER | 1 | | | | |
| 4 | 1911506301 | ▪ BRACKET | 1 | | | | |
| 5 | 1911506302 | ▪ HOSE | 1 | | | | |
| | 1911505602 | ▪ ▪ O-RING | 1 | | | | RD-5-4017-013 |
| 6 | 1911506304 | ▪ HOSE | 1 | | | | |
| | 1911505601 | ▪ ▪ O-RING | 1 | | | | RD-5-4017-011 |
| 7 | 1911506403 | ▪ HOSE | 1 | | | | |
| | 1911505601 | ▪ ▪ O-RING | 1 | | | | RD-5-4017-011 |
| 8 | 1100040816 | ▪ BOLT | 2 | | | | |
| 9 | 1140020008 | ▪ WASHER, spring | 2 | | | | |
| 11 | 1110040512 | ▪ SCREW, cap | 8 | | | | |
| 12 | 1100040625 | ▪ BOLT | 4 | | | | |
| 13 | 1140020005 | ▪ WASHER, spring | 8 | | | | |
| 14 | 1141110006 | ▪ WASHER | 4 | | | | |
| 15 | 0394614620 | ▪ BRACKET | 1 | | | | |
| 16 | 0394614230 | ▪ BRACKET | 1 | | | | |
| 17 | 1652231100 | ▪ BAND | 2 | | | | |
| 18 | 1652520006 | ▪ NUT | 4 | | | | |
| | K3e313 | | | | | | |

AIR CONDITIONER (5/6) (14514866-)

| Item | Part number | Description | Q'ty | Chan. | Serial No. | Serv. | Remarks |
|------|---------------|---|------|-------|------------|-------|-------------------|
| | | CONDITIONER ASSY, air | | | | | X03946-16000-1 |
| | | CONDITIONER ASSY, air (for the tropics) | | | | | X03946-16500-1 |
| 0 | X 0394614800 | DEFROSTER ASSY | 1 | | | | X03946-14800-3 |
| 1 | 0394612340 | • COVER | 1 | | | | |
| 2 | 1911505720 | • DUCT ASSY | 2 | | | | |
| 3 | 1911505670 | • CLAMP | 6 | | | | |
| 5 | 1911506020 | • PANEL ASSY, control | 1 | | | | see page (6/6) |
| 6 | 0394615140 | • HOSE ASSY, duct | 1 | | | | |
| 6-1 | 1911508591 | • • HOSE | 1 | | | | |
| 6-2 | 0394615141 | • • INSULATOR | 1 | | | | |
| 6-3 | 1652201007 | • • BAND | 5 | | | | |
| 7 | 1911508539 | • HOSE | 1 | | | | |
| 8 | 1911508567 | • HOSE | 1 | | | | |
| 10 | 1911505730 | • BRACKET | 1 | | | | |
| 11 | 1911505810 | • SCREW | 2 | | | | |
| 13 | 1652002201 | • GROMMET | 1 | | | | |
| 15 | 1652261410 | • BAND | 6 | | | | |
| 16 | 1150420514 | • SCREW | 6 | | | | |
| 18 | 1100040612 | • BOLT | 2 | | | | |
| 19 | 1140020006 | • WASHER, spring | 2 | | | | |
| 20 | 1141110006 | • WASHER | 2 | | | | |
| 21 | 1150420510 | • BOLT, sems | 10 | | | | |
| 22 | 1654606050 | • SEAL | 1 | | | | sold by the meter |
| 23 | 1653916023 | • TRIM | 1 | | | | sold by the meter |
| 25 | 0394612710 | • BRACKET | 1 | | | | |
| 26 | 1911506060 | • LOUVER | 1 | | | | |
| 27 | 1653916026 | • TRIM | 1 | | | | sold by the meter |
| 28 | 1110090512 | • SCREW, cap | 4 | | | | |
| 29 | 1140090005 | • WASHER, spring | 4 | | | | |
| 30 | 1141190005 | • WASHER | 4 | | | | |
| | K3e403 | | | | | | |

| Item | Part number | Description | BOOM | | Serial No. | Serv. | Remarks |
|------|-------------|---------------------------------|------|--------|-------------------|-------|------------------------|
| | | | Q'ty | Chan. | | | |
| | | BOOM ASSY | | | | | X03960-14700-3 |
| | | BOOM ASSY (with shut-off valve) | | | | | X03960-15000-3 |
| 1 | 0396008100 | BOOM SUB ASSY | 1 | | 14510004~14512798 | | |
| | 0396010100 | BOOM SUB ASSY | 1 | | 14512799~14515345 | | |
| | 0396014800 | BOOM SUB ASSY | 1 | | 14515346~ | | |
| 1-26 | 0002400055 | • BUSHING | 2 | | 14512799~14515345 | | |
| | 0002400048 | • BUSHING | 2 | | 14515346~14515477 | | |
| | 0002400078 | • BUSHING | 2 | (H) | 14515478~ | | |
| 1-27 | 1432200055 | • SEAL, dust | 2 | | 14512799~14515345 | | |
| | 1432200060 | • SEAL, dust | 2 | | 14515346~ | | |
| 2 | 0396008300 | COVER, rod | 1 | (L) | 14510004~14510150 | | |
| | 0396008370 | COVER, rod | 1 | (H) | 14510151~14510476 | | |
| | 0396008400 | COVER, rod | 1 | (H) | 14510477~14510788 | | |
| | 0396010400 | COVER, rod | 1 | | 14510789~ | | |
| 3 | 0396005300 | PIPE | 2 | | | | |
| 4 | 0396002500 | PIPE | 2 | | | | |
| 5 | 1534000018 | CLAMP | 5 | | | | |
| 6 | 0007300058 | CLAMP | 1 | | | | |
| 7 | 1515600202 | ADAPTOR | 2 | | | | |
| | 1420010180 | • O-RING | 1 | | | | |
| 8 | 0396008500 | COVER | 1 | | 14510004~14510417 | | without shut-off valve |
| | 0396009100 | COVER | 1 | | 14510418~ | | without shut-off valve |
| 9 | 0376006282 | CLAMP | 2 | | | | |
| 10 | 0376007500 | GUARD | 1 | | | | |
| 11 | 0396008600 | RUBBER | 1 | | | | |
| 12 | 0011576001 | PIN | 1 | | 14510004~14510417 | | |
| | 0011576003 | PIN | 1 | | 14510418~14515345 | | |
| | 0011577001 | PIN | 1 | (L) | 14515346~14515477 | | |
| | 0011577002 | PIN | 1 | | 14515478~ | | |
| 13 | 0011515006 | PIN | 1 | | 14510004~14515345 | | |
| | 0011517005 | PIN | 1 | (L) | 14515346~14515477 | | |
| | 0011517006 | PIN | 1 | | 14515478~ | | |
| 14 | 0001605215 | PIN | 1 | | | | |
| 15 | 0011905003 | PIN | 1 | | | | |
| 16 | 0003900019 | WASHER | 1 | | | | |
| 17 | 1132630039 | NUT | 1 | | | | |
| 18 | 1210010670 | PIN, split | 1 | | | | |
| 19 | 0003600057 | WASHER | 1 | | | | |
| 20 | 1225120022 | WASHER, conical | 1 | | | | |
| 21 | 1100040816 | BOLT | 4 | | | | |
| 22 | 1100040840 | BOLT | 7 | | | | |
| 23 | 1100041016 | BOLT | 1 | | | | |
| 24 | 1103041295 | BOLT | 2 | | | | |
| 25 | 1101041220 | BOLT | 1 | | | | |
| 26 | 1140020008 | WASHER, spring | 11 | | | | |
| 27 | 1140020010 | WASHER, spring | 1 | | | | |
| 28 | 1140020012 | WASHER, spring | 2 | | | | |
| 29 | 1141110008 | WASHER | 4 | | | | |
| 30 | 1141110010 | WASHER | 1 | | | | |
| 31 | 1141110012 | WASHER | 2 | | | | |
| 32 | 1100041230 | BOLT | 1 | | | | |
| 33 | 1140330012 | WASHER | 2 | | | | |
| 34 | 1703002700 | LAMP ASSY | 1 | | | | |
| 34-1 | 1703002706 | • BULB | 1 | | | | |
| 35 | 1103141205 | BOLT | 1 | | 14510004~14510417 | | |
| | 1103141225 | BOLT | 1 | | 14510418~ | | |
| 36 | 1103141220 | BOLT | 1 | | 14510004~14510417 | | |
| | 1103141240 | BOLT | 1 | | 14510418~ | | |
| 37 | 1130240012 | NUT | 8 | | | | |
| 38 | 0003600096 | SHIM | AR | | | | t=1.0 |
| 39 | 0003600098 | SHIM | AR | | 14510004~14515345 | | t=1.0 |
| | 0003600099 | SHIM | AR | | 14515346~ | | t=1.0 |
| 40 | 1560001000 | FITTING, grease | 2 | | | | |
| 41 | 0434200600 | WIRE | 1 | | | | |
| 42 | 1900075600 | CYLINDER, boom | 1 | A(L) | 14510004~14510476 | | without shut-off valve |
| | 1900080500 | CYLINDER, boom | 1 | a(H) | 14510477~14510788 | | without shut-off valve |
| | 1900079900 | CYLINDER, boom | 1 | (H)(L) | 14510789~14512426 | | without shut-off valve |

CLICK HERE TO **DOWNLOAD** THE COMPLETE MANUAL

- Thank you very much for reading the preview of the manual.
- You can download the complete manual from: www.heydownloads.com by clicking the link below



- Please note: If there is no response to CLICKING the link, please download this PDF first and then click on it.

CLICK HERE TO **DOWNLOAD** THE COMPLETE MANUAL

TELESCOPIC ARM (2/2)

| Item | Part number | Description | Q'ty | Chan. | Serial No. | Serv. | Remarks |
|------|-------------------|----------------------|------|-------|-------------------|-------|----------------|
| | | ARM ASSY, telescopic | | | | | X03961-09000-3 |
| 13 | 0376109500 | GUIDE | 2 | | 14510004~14510757 | | |
| 14 | 0007200156 | NUT | 2 | | | | |
| 15 | 0007200189 | ADAPTOR | 2 | | | | |
| 16 | 0007203025 | ADAPTOR | 2 | | | | |
| 17 | 0007236040 | ADAPTOR | 2 | | | | |
| 25 | 1100240860 | BOLT | 2 | | 14510004~14510757 | | |
| | 1100240850 | BOLT | 2 | | 14510758~ | | |
| 33 | 1130040008 | NUT | 2 | | 14510004~14510757 | | |
| 36 | 1140020008 | WASHER, spring | 2 | | | | |
| 39 | 1141110008 | WASHER | 2 | | 14510004~14510757 | | |
| 42 | 1420010110 | O-RING | 2 | | | | |
| 45 | 1515100112 | ELBOW | 2 | | | | |
| | 1420010180 | · O-RING | 1 | | | | |
| 48 | 1801601056 | HOSE ASSY | 2 | | | | |
| 49 | 1935312095 | HOSE ASSY | 2 | | | | |
| 50 | 1801640112 | HOSE ASSY | 2 | | 14510004~14510757 | | |
| | 1801640092 | HOSE ASSY | 2 | | 14510758~ | | |
| 53 | 0396109600 | PIPE | 1 | | | | |
| 54 | 0396109700 | PIPE | 1 | | | | |
| | K3f041 | | | | | | |

BUCKET 4 (1451#-)

| Item | Part number | Description | Q'ty | Chan. | Serial No. | Serv. | Remarks |
|------|-------------------|--------------------|------|-------|------------|-------|-----------------|
| 0 | 0396217400 | BUCKET ASSY | 1 | | | | 610wide No23613 |
| 1 | X ***** | ▪ BUCKET | 1 | | | | |
| 1-14 | 1914200381 | ▪ ▪ ADAPTOR, tooth | 4 | | | | |
| 2 | 1914200182 | ▪ POINT, tooth | 4 | | | | |
| 3 | 1914200184 | ▪ PIN | 4 | | | | |
| 4 | 1914200183 | ▪ PIN | 4 | | | | |
| | K3f220 | | | | | | |

2ND AUXILIARY LINE (2/2)

| Item | Part number | Description | Q'ty | Chan. | Serial No. | Serv. | Remarks |
|------|-------------------|--|------|-------|-------------------|-------|-------------------|
| 0 | 0397311000 | LINE ASSY, 2nd aux. | 1 | | 14510004~14515345 | | X03973-11000-8 |
| | 0397323000 | LINE ASSY, 2nd aux. | 1 | | 14515346~ | | X03973-23000-3 |
| | 0397312000 | LINE ASSY, 2nd aux. (long arm) | 1 | | 14510004~14515345 | | X03973-12000-8 |
| | 0397323100 | LINE ASSY, 2nd aux. (long arm) | 1 | | 14515346~ | | X03973-23100-3 |
| | 0397312500 | LINE ASSY, 2nd aux. (middle arm) | 1 | | 14510004~14515345 | | X03973-12500-8 |
| | 0397323200 | LINE ASSY, 2nd aux. (middle arm) | 1 | | 14515346~14516341 | | X03973-23200-2 |
| | 0397325200 | LINE ASSY, 2nd aux. (middle arm) | 1 | | 14516342~ | | X03973-25200-0 |
| | 0397311600 | LINE ASSY, 2nd aux. (with air con.) | 1 | | 14510004~14515345 | | X03973-11600-8 |
| | 0397323300 | LINE ASSY, 2nd aux. (with air con.) | 1 | | 14515346~ | | X03973-23300-3 |
| | 0397311700 | LINE ASSY, 2nd aux. (long arm) (with air con.) | 1 | | 14510004~14515345 | | X03973-11700-8 |
| | 0397323400 | LINE ASSY, 2nd aux. (long arm) (with air con.) | 1 | | 14515346~ | | X03973-23400-3 |
| | 0397311800 | LINE ASSY, 2nd aux. (middle arm) (with air con.) | 1 | | 14510004~14515345 | | X03973-11800-8 |
| | 0397323500 | LINE ASSY, 2nd aux. (middle arm) (with air con.) | 1 | | 14515346~14516341 | | X03973-23500-2 |
| | 0397325300 | LINE ASSY, 2nd aux. (middle arm) (with air con.) | 1 | | 14516342~ | | X03973-25300-0 |
| 8 | 1100040840 | • BOLT | 4 | | | | |
| 11 | 1140020008 | • WASHER, spring | 4 | | | | |
| 34 | 1730140730 | • CONTROLLER | 1 | | | | |
| 42 | 0397311250 | • HARNESS, wiring | 1 | | 14510004~14514853 | | |
| | 0397321000 | • HARNESS, wiring | 1 | | 14514854~ | | |
| | 0397311650 | • HARNESS, wiring | 1 | | 14510004~14514853 | | with air con. |
| | 0397321100 | • HARNESS, wiring | 1 | | 14514854~ | | with air con. |
| 42-1 | 1730500008 | • • DIODE (3A, yellow) | 3 | | | | |
| 42-2 | 1531325050 | • • PROTECTOR | 1 | | | | sold by the meter |
| 43 | 1652231250 | • BAND | 14 | | | | |
| 47 | 0569349961 | • DECAL | 1 | | | | |
| 48 | 0399352600 | • DECAL | 1 | | | | |
| | K3f115 | | | | | | |

3RD AUXILIARY LINE (2/2) (available only with the 2nd aux. lines)

| Item | Part number | Description | Q'ty | Chan. | Serial No. | Serv. | Remarks |
|------|-------------------|--|------|-------|-------------------|-------|----------------|
| 0 | 0397313000 | LINE ASSY, 3rd aux. | 1 | | 14510004~14513260 | | X03973-13000-6 |
| | 0397320000 | LINE ASSY, 3rd aux. | 1 | | 14513261~14515345 | | X03973-20000-1 |
| | 0397323800 | LINE ASSY, 3rd aux. | 1 | | 14515346~ | | X03973-23800-3 |
| | 0397325400 | LINE ASSY, 3rd aux. (middle arm) | 1 | | 14516342~ | | X03973-25400-0 |
| | 0397320500 | LINE ASSY, 3rd aux. (with air con.) | 1 | | 14514362~14515345 | | X03973-20500-1 |
| | 0397323900 | LINE ASSY, 3rd aux. (with air con.) | 1 | | 14515346~ | | X03973-23900-3 |
| | 0397325500 | LINE ASSY, 3rd aux. (middle arm) (with air con.) | 1 | | 14516342~ | | X03973-25500-0 |
| 8 | 1140020008 | • WASHER, spring | 4 | | | | |
| 20 | 1100040820 | • BOLT | 4 | | | | |
| 25 | 1700550032 | • LAMP, pilot | 1 | | | | |
| 26 | 1711900062 | • RELAY | 1 | | | | |
| 29 | 0567336130 | • DECAL | 1 | | | | |
| 30 | 1700100064 | • SWITCH, foot | 1 | | | | |
| 31 | 1130040006 | • NUT | 1 | | | | |
| 32 | 1140020006 | • WASHER, spring | 1 | | | | |
| 33 | 1141110006 | • WASHER | 1 | | | | |
| 37 | 0872433150 | • TUBE | 2 | | | | |
| | K3f144 | | | | | | |

DECAL (for Japan; 14513261-)

| Item | Part number | Description | Q'ty | Chan. | Serial No. | Serv. | Remarks |
|------|-------------|--------------------|------|-------|------------|-------|----------------|
| 0 | 0399354500 | DECAL SET (canopy) | 1 | | | | X03993-54500-4 |
| | 0399354400 | DECAL SET (cab) | 1 | | | | X03993-54400-4 |
| 1 | 0399337100 | • DECAL | 2 | | | | |
| 2 | 0329350200 | • DECAL | 1 | | | | |
| 3 | 0359306300 | • DECAL | 2 | | | | |
| 4 | 0569321400 | • DECAL | 1 | | | | cab |
| 5 | 0399354405 | • DECAL | 1 | | | | |
| 6 | 0399345200 | • DECAL | 1 | | | | |
| 7 | 0379336800 | • DECAL | 1 | | | | |
| 8 | 0359325220 | • DECAL | 1 | | | | |
| 9 | 0379345400 | • DECAL | 1 | | | | |
| 10 | 0379345300 | • DECAL | 1 | | | | |
| 11 | 0339350020 | • DECAL | 2 | | | | |
| 12 | 0329360400 | • DECAL | 2 | | | | |
| 13 | 0339350040 | • DECAL | 1 | | | | |
| 14 | 0339350050 | • DECAL | 1 | | | | |
| 15 | 0339350060 | • DECAL | 1 | | | | |
| 16 | 0339350070 | • DECAL | 1 | | | | |
| 17 | 0339350080 | • DECAL | 1 | | | | |
| 18 | 0339350090 | • DECAL | 1 | | | | |
| 19 | 0339350110 | • DECAL | 2 | | | | |
| 21 | 0339350130 | • DECAL | 2 | | | | cab |
| 22 | X ***** | • DECAL | 1 | | | | |
| 23 | X ***** | • SCREW | 4 | | | | |
| 24 | X ***** | • DECAL | 1 | | | | |
| 25 | 0379358560 | • DECAL | 2 | | | | |
| 26 | 0329360060 | • DECAL | 1 | | | | |
| 27 | 0329360100 | • DECAL | 1 | | | | |
| 28 | 0349325020 | • DECAL | 1 | | | | canopy |
| 29 | 0359306700 | • DECAL | 1 | | | | |
| 30 | 0359317200 | • DECAL | 1 | | | | |
| 31 | 0359325020 | • DECAL | 1 | | | | |
| 32 | 0359325030 | • DECAL | 1 | | | | |
| 33 | 0359325080 | • DECAL | 1 | | | | |
| 34 | 0359325090 | • DECAL | 1 | | | | |
| 35 | 0359313900 | • DECAL | 1 | | | | |
| 36 | 0359325140 | • DECAL | 1 | | | | |
| 37 | 0359325190 | • DECAL | 1 | | | | |
| 38 | 0379336600 | • DECAL | 1 | | | | |
| 39 | 0871082120 | • DECAL | 1 | | | | |
| 40 | 0871082240 | • DECAL | 1 | | | | |
| 41 | 0871082280 | • DECAL | 1 | | | | |
| 42 | 0871082300 | • DECAL | 1 | | | | |
| 43 | 0871082220 | • DECAL | 1 | | | | |
| 45 | 0394504900 | • DECAL | 1 | | | | cab |
| 46 | 0189311800 | • DECAL | 1 | | | | cab |
| 47 | 0339352010 | • DECAL | 1 | | 14512022~ | | |
| 48 | 0339352020 | • DECAL | 1 | | 14512022~ | | |
| 49 | 0339352040 | • DECAL | 1 | | 14512022~ | | |
| 50 | 0339352050 | • DECAL | 1 | | 14512022~ | | |
| 51 | 0339377640 | • DECAL | 1 | | | | |

K3g016

DECAL (canopy) (14510004-14513260)

| Item | Part number | Description | Q'ty | Chan. | Serial No. | Serv. | Remarks |
|------|-------------------|-------------------|------|-------|------------|-------|---------|
| 30 | 0339375820 | • DECAL (Spanish) | 1 | | | | |
| 31 | 0339375040 | • DECAL (English) | 1 | | | | |
| 31 | 0339375240 | • DECAL (German) | 1 | | | | |
| 31 | 0339375440 | • DECAL (French) | 1 | | | | |
| 31 | 0339375640 | • DECAL (Italian) | 1 | | | | |
| 31 | 0339375840 | • DECAL (Spanish) | 1 | | | | |
| 32 | 0339375050 | • DECAL (English) | 1 | | | | |
| 32 | 0339375250 | • DECAL (German) | 1 | | | | |
| 32 | 0339375450 | • DECAL (French) | 1 | | | | |
| 32 | 0339375650 | • DECAL (Italian) | 1 | | | | |
| 32 | 0339375850 | • DECAL (Spanish) | 1 | | | | |
| | K3g032 | | | | | | |

TB145 Book No. BK3Z010 S/N 14510004-
UK TAKEUCHI

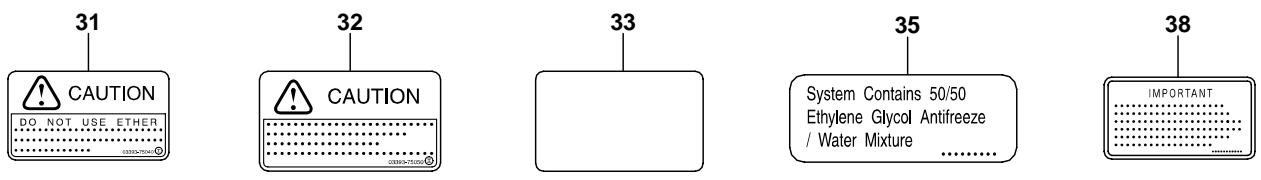
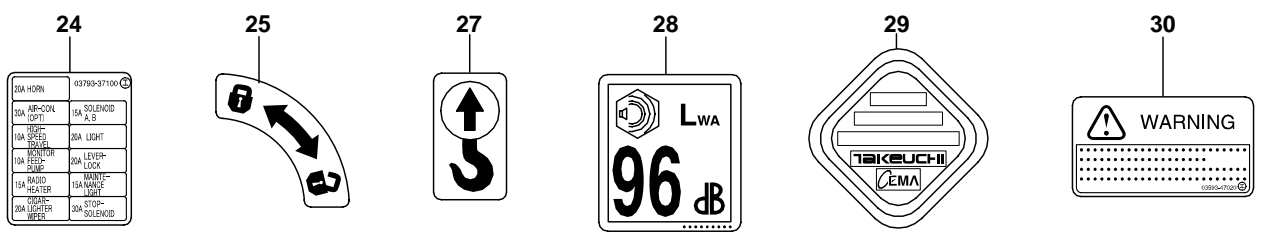
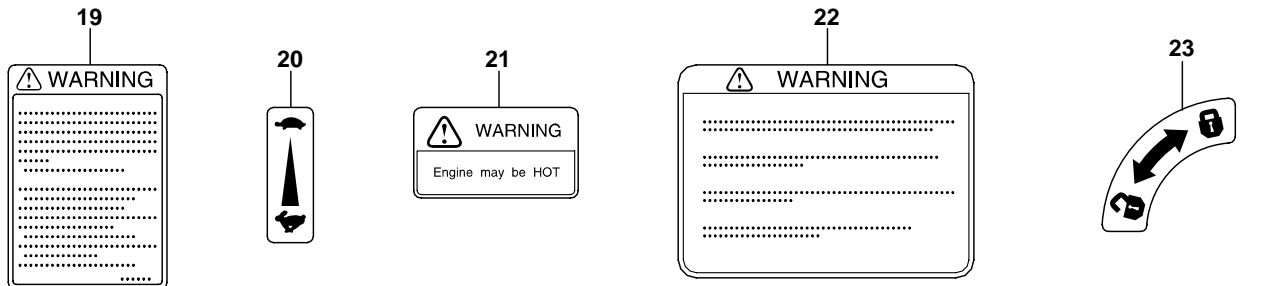
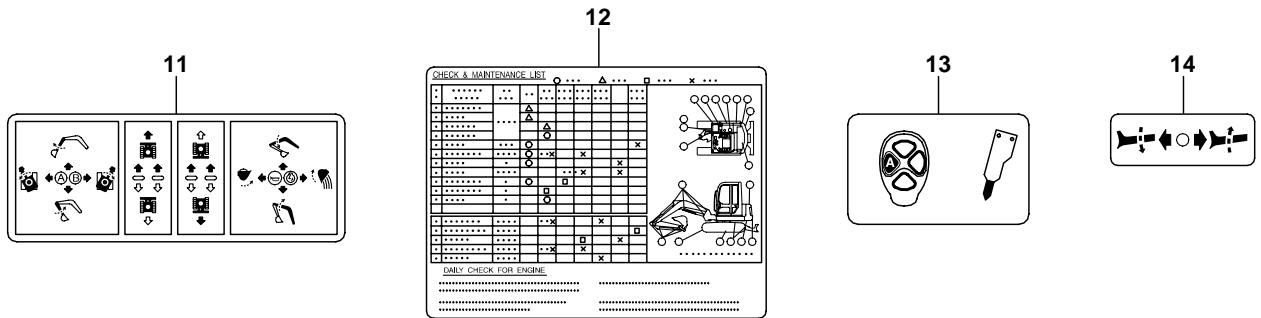
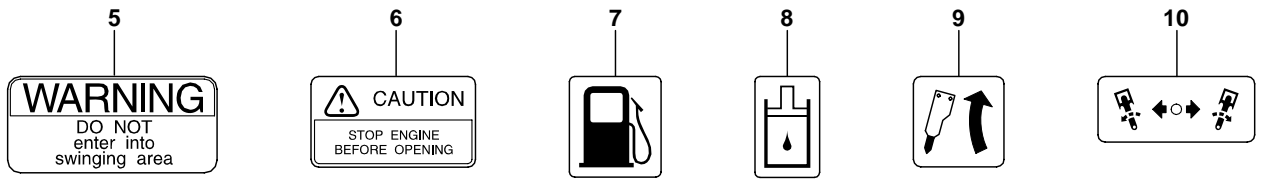
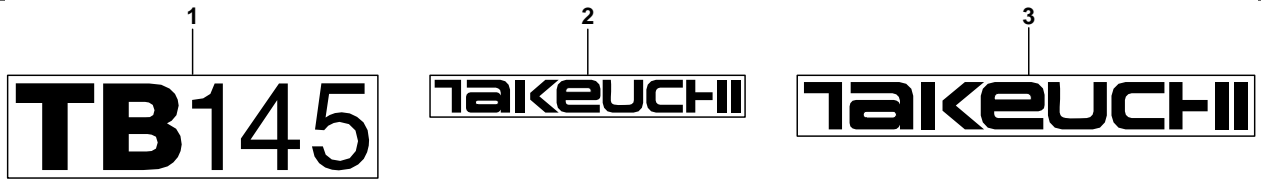

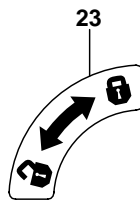
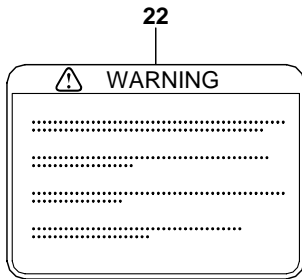
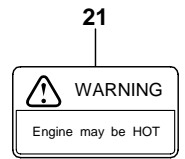
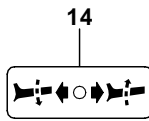
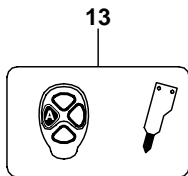
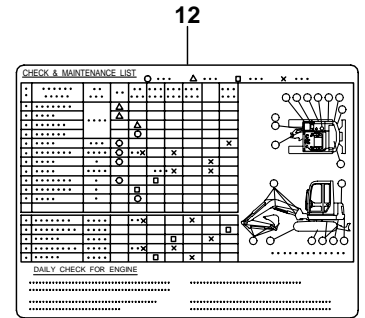
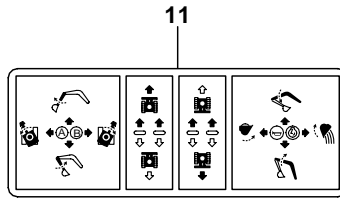
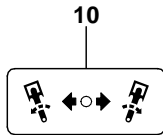
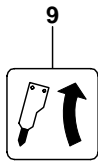
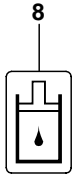
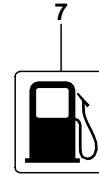
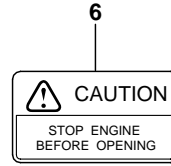
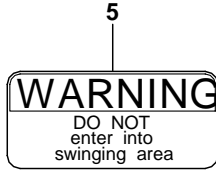
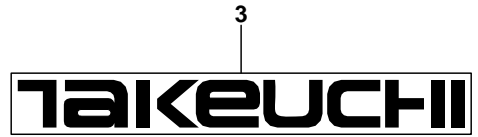
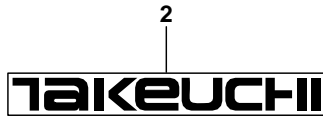
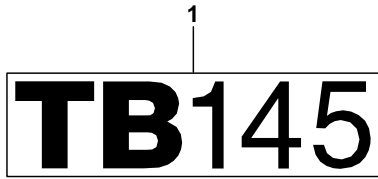

24

| | |
|--------------------|-------------------|
| 10A HORN | 03700-371000 |
| 10A AIR-COOL (WPT) | 10A SOLENOID |
| 10A SPEED BRAKE | 10A S.S. |
| 10A MONITOR | 20A LIGHT |
| 10A PEEC-2000 | 20A LEVER-LOOK |
| 10A RADIO HEATER | 10A WASTE-PIPE |
| 20A LIGHTER | 20A STOP-SOLENOID |

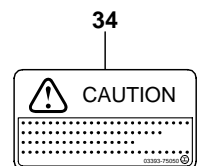
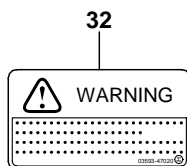
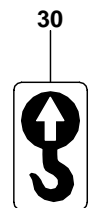
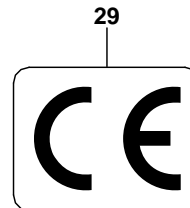
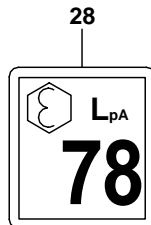
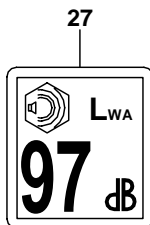
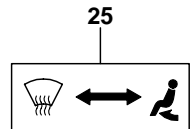

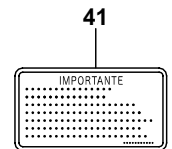
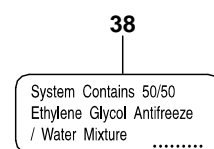
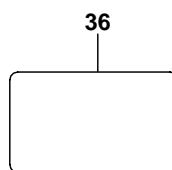
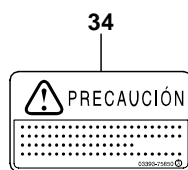
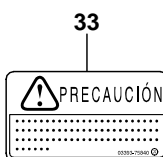
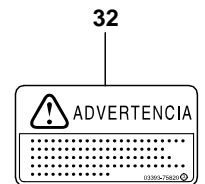
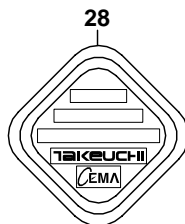
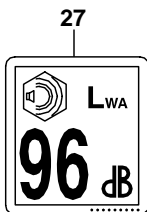
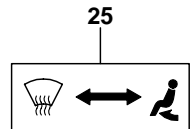
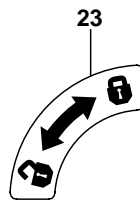
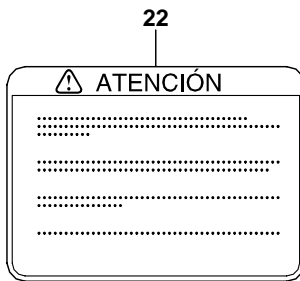
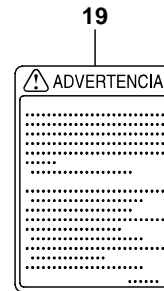
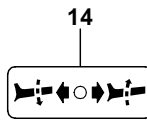
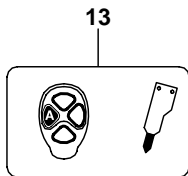
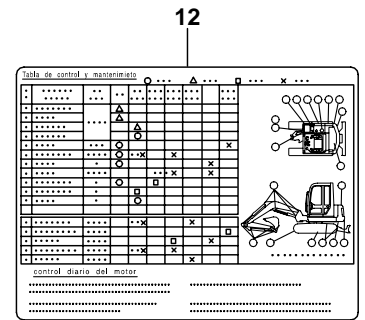
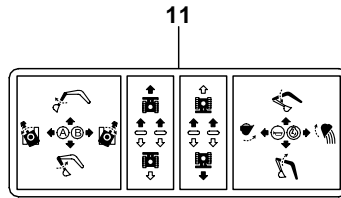
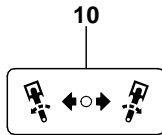
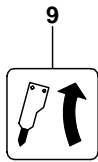
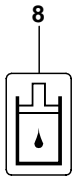
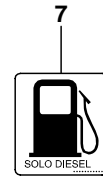
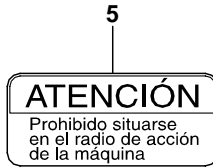
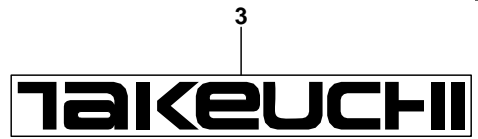
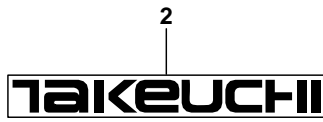
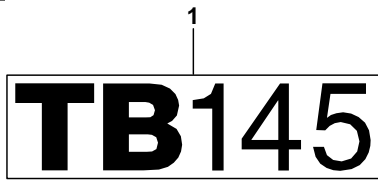

| Item | Part number | Description | Q'ty | DECAL (for EU) | | | Remarks |
|------|-------------------|-------------|------|----------------|------------|-------|----------------|
| | | | | Chan. | Serial No. | Serv. | |
| 0 | X ***** | DECAL SET | 1 | | | | X03993-47000-2 |
| 1 | X ***** | ▪ DECAL | 1 | | | | |
| 2 | X ***** | ▪ DECAL | 1 | | | | |
| 4 | X ***** | ▪ DECAL | 1 | | | | |
| 5 | 0399300500 | ▪ DECAL | 3 | | | | |
| 6 | 0379347200 | ▪ DECAL | 1 | | | | |
| 7 | 0339355200 | ▪ DECAL | 1 | | | | |
| | K3g131 | | | | | | |

| Item | Part number | Description | DECAL (TOPS; canopy) | | | Remarks |
|------|----------------------|-------------|----------------------|-------|------------------|----------------|
| | | | Q'ty | Chan. | Serial No. Serv. | |
| 0 | X ***** | DECAL SET | 1 | | | X03793-57000-0 |
| 1 | X ***** | · DECAL | 1 | | | |
| 2 | 1122800006 G4g220 | · SCREW | 4 | | | |

TOOL & ACCESSORIES (2/2) (for China)

| Item | Part number | Description | Q'ty | Chan. | Serial No. | Serv. | Remarks |
|------|-------------------|--------------------|------|-------|------------|-------|-------------------------|
| | | TOOL SET | | | | | X03992-11450-1 |
| 4 | 1551102600 | FILTER, return | 5 | | | | |
| 5 | 1990197054 | FILTER, fuel | 8 | | | M | Y129907-55800 |
| 6 | 1990197055 | FILTER, engine oil | 9 | | | M | Y119005-35150 |
| 7 | 1911102771 | AIR FILTER, outer | 4 | | | M | fhfjf\fhf\fhf" P82-1575 |
| 8 | 1911102772 | AIR FILTER, inner | 4 | | | | fhfjf\fhf\fhf" P82-2858 |
| | K3g300 | | | | | | |

BLOCK ASSY; No. 1

| Item | Part number | Description | Q'ty | Chan. | Serial No. | Serv. | Remarks |
|------|-------------------|------------------|------|-------|-------------------|-------|---------|
| 0 | 1901036513 | BLOCK ASSY; No.1 | 1 | | 14510004~14514823 | | bucket |
| | 1901043013 | BLOCK ASSY; No.1 | 1 | | 14514824~ | | bucket |
| 1 | 1901036566 | · CAP | 1 | | | | |
| 2 | 1901036531 | · END, spool | 1 | | | | |
| 3 | 1901029754 | · HOLDER, spring | 1 | | | | |
| 4 | 1901036556 | · SPRING | 1 | | | | |
| 5 | 1901036551 | · HOLDER, spring | 1 | | | | |
| 6 | 1420500240 | · O-RING | 2 | | | | |
| 7 | 1901036567 | · CAP | 1 | | | | |
| 8 | 1110020618 | · SCREW, cap | 4 | | | | |
| 9 | 1901025467 | · PLUNGER | 1 | | | | |
| 10 | 1901034239 | · SPRING | 1 | | | | |
| 11 | 1420100650 | · O-RING | 1 | | | | |
| 12 | 1901036526 | · PLUNGER | 1 | | | | |
| | K3h031 | | | | | | |

BLOCK ASSY; No. 5

| Item | Part number | Description | Q'ty | Chan. | Serial No. | Serv. | Remarks |
|------|-------------------|------------------------------|------|-------|-------------------|-------|---------|
| 0 | 1901036518 | BLOCK ASSY; No.5 | 1 | | 14510004~14514823 | | swing |
| | 1901043018 | BLOCK ASSY; No.5 | 1 | | 14514824~ | | swing |
| | 1901040618 | BLOCK ASSY; No.5 (high flow) | 1 | | 14510004~14514823 | | swing |
| | 1901043718 | BLOCK ASSY; No.5 (high flow) | 1 | | 14514824~ | | swing |
| 1 | 1901025483 | ▪ PLATE, seal | 2 | | | | |
| 2 | 1901025484 | ▪ O-RING | 2 | | | | |
| 3 | 1901025485 | ▪ SEAL | 2 | | | | |
| 4 | 1901025462 | ▪ CAP | 1 | | | | |
| 5 | 1901025453 | ▪ HOLDER, spring | 2 | | | | |
| 6 | 1901025432 | ▪ END, spool | 1 | | | | |
| 7 | 1901025457 | ▪ SPRING | 1 | | | | |
| 8 | 1901025467 | ▪ PLUNGER | 1 | | | | |
| 9 | 1901034239 | ▪ SPRING | 1 | | | | |
| 10 | 1420100650 | ▪ O-RING | 1 | | | | |
| 11 | 1120540610 | ▪ SCREW | 2 | | | | |
| 12 | 1110020618 | ▪ SCREW, cap | 2 | | | | |
| | K3h082 | | | | | | |

BLOCK ASSY; No. 10

| Item | Part number | Description | Q'ty | Chan. | Serial No. | Serv. | Remarks |
|------|-------------------|-------------------|------|-------|-------------------|-------|---------|
| 0 | 1901036517 | BLOCK ASSY; No.10 | 1 | | 14510004~14514823 | | blade |
| | 1901043017 | BLOCK ASSY; No.10 | 1 | | 14514824~ | | blade |
| 1 | 1901025483 | ▪ PLATE, seal | 2 | | | | |
| 2 | 1901025484 | ▪ O-RING | 2 | | | | |
| 3 | 1901025485 | ▪ SEAL | 2 | | | | |
| 4 | 1901025462 | ▪ CAP | 1 | | | | |
| 5 | 1901025453 | ▪ HOLDER, spring | 2 | | | | |
| 6 | 1901025432 | ▪ END, spool | 1 | | | | |
| 7 | 1901025457 | ▪ SPRING | 1 | | | | |
| 8 | 1901025467 | ▪ PLUNGER | 1 | | | | |
| 9 | 1901034239 | ▪ SPRING | 1 | | | | |
| 10 | 1420100650 | ▪ O-RING | 1 | | | | |
| 11 | 1120540610 | ▪ SCREW | 2 | | | | |
| 12 | 1110020618 | ▪ SCREW, cap | 2 | | | | |
| | K3h131 | | | | | | |

PILOT VALVE (L) (with the 2nd auxiliary lines; 14513261-)

| Item | Part number | Description | Q'ty | Chan. | Serial No. | Serv. | Remarks |
|------|-------------------|-------------------|------|-------|------------|-------|---------|
| 0 | 1901746500 | VALVE ASSY, pilot | 1 | | | | |
| 1 | 1901745702 | • PLATE | 1 | | | | |
| 2 | 1901710912 | • PLUG | 4 | | | | |
| 3 | 1901719011 | • ROD | 2 | | | | |
| 4 | 1901719012 | • ROD | 2 | | | | |
| 5 | 1901710914 | • SEAL | 4 | | | | |
| 6 | 1420010200 | • O-RING | 4 | | | | |
| 7 | 1901745709 | • HOLDER | 2 | | | | |
| 8 | 1901745710 | • HOLDER | 2 | | | | |
| 9 | 1901710917 | • WASHER | 4 | | | | |
| 10 | 1901745612 | • SPRING | 4 | | | | |
| 11 | 1901742614 | • SPRING | 2 | | | | |
| 12 | 1901742615 | • SPRING | 2 | | | | |
| 13 | 1901720232 | • JOINT | 1 | | | | |
| 14 | 1901743620 | • PLATE | 1 | | | | |
| 15 | 1901735625 | • NUT | 1 | | | | |
| 16 | 1901735626 | • NUT | 1 | | | | |
| 17 | 1901740432 | • LEVER | 1 | | | | |
| 18 | 1901741210 | • HANDLE | 1 | | | | |
| 19 | 1901746521 | • PIN, spring | 1 | | | | |
| 20 | 1901735630 | • BUSHING | 1 | | | | |
| 21 | 1901740446 | • RECEPTACLE | 1 | | | | |
| 22 | 1901740447 | • WEDGE | 1 | | | | |
| 23 | 1901741263 | • PLUG | 3 | | | | |
| 24 | 1901735632 | • BOOT | 1 | | | | |
| | K3h440 | | | | | | |

ROTARY VALVE

| Item | Part number | Description | Q'ty | Chan. | Serial No. | Serv. | Remarks |
|------|---------------------|---------------|------|-------|------------|-------|---------|
| 0 | 1901733700 | VALVE, rotary | 1 | | | | |
| 0-1 | 1901733799 | • KIT, seal | 1 | | | | |
| 1 | X 1901733717 | • • SEAL, oil | 1 | | | | |
| 2 | X 1420010220 | • • O-RING | 1 | | | | |
| 3 | X 1420500650 | • • O-RING | 2 | | | | |
| 4 | X 1420500080 | • • O-RING | 8 | | | | |
| 5 | 1901733701 | • CASE | 1 | | | | |
| 6 | 1901733702 | • SLEEVE | 1 | | | | |
| 7 | 1901733703 | • SHAFT | 1 | | | | |
| 8 | 1901733704 | • COVER | 1 | | | | |
| 9 | 1901733705 | • LEVER | 1 | | | | |
| 10 | 1901733706 | • COVER | 1 | | | | |
| 11 | 1110040830 | • SCREW, cap | 1 | | | | |
| 12 | 1110040816 | • SCREW, cap | 6 | | | | |
| 13 | 1110040825 | • SCREW, cap | 6 | | | | |
| 14 | 1213000426 | • PIN, spring | 1 | | | | |
| 15 | 1213000824 | • PIN, spring | 2 | | | | |
| 16 | 1390010400 | • BALL, steel | 1 | | | | |
| 17 | 1901733716 | • BEARING | 4 | | | | |
| 18 | 1501810000 | • PLUG | 8 | | | | |
| | G4h290 | | | | | | |

SHUT-OFF VALVE (with pilot)

| Item | Part number | Description | Q'ty | Chan. | Serial No. | Serv. | Remarks |
|------|-------------------|--------------------------|------|-------|------------|-------|---------|
| 0 | 1901742700 | VALVE ASSY, load holding | 1 | | | | boom |
| | 1901742800 | VALVE ASSY, load holding | 1 | | | | arm |
| 0-1 | 1901742799 | · KIT, seal | 1 | | | | |
| 1 | 1901742904 | · · O-RING | 1 | | | | |
| 2 | 1901742908 | · · RING, back-up | 1 | | | | |
| 3 | 1901742708 | · · O-RING | 1 | | | | |
| 4 | 1901742901 | · CAP | 1 | | | | |
| 5 | 1901742902 | · PLUG | 1 | | | | |
| 6 | 1901742903 | · PLUG | 2 | | | | |
| 7 | 1901742704 | · SOCKET | 1 | | | | |
| 8 | 1901742906 | · SEAL | 1 | | | | |
| 9 | 1901742907 | · PLUG | 1 | | | | |
| 10 | 1901742909 | · PLUG | 1 | | | | |
| 11 | 1901742711 | · CAP | 1 | | | | |
| | K3h380 | | | | | | |

ARM CYLINDER (14510004-14510788)

| Item | Part number | Description | Q'ty | Chan. | Serial No. | Serv. | Remarks |
|------|---------------------|---------------------|------|-------|------------|-------|---------|
| 0 | 1900075700 | CYLINDER ASSY | 1 | | | | arm |
| 0-1 | 1900075799 | • KIT, seal | 1 | | | | |
| 1 | X 1410220900 | • • PACKING, piston | 1 | | | | |
| 2 | X 1410550662 | • • PACKING, rod | 1 | | | | |
| 3 | X 1411266503 | • • RING, back-up | 1 | | | | |
| 4 | X 1900075723 | • • SEAL, dust | 1 | | | | |
| 5 | X 1420110900 | • • O-RING | 1 | | | | |
| 6 | X 1420110850 | • • O-RING | 1 | | | | |
| 7 | X 1900075735 | • • RING, back-up | 1 | | | | |
| 8 | X 1420110850 | • • O-RING | 1 | | | | |
| 9 | X 1421130850 | • • RING, back-up | 1 | | | | |
| 10 | X 1420110400 | • • O-RING | 2 | | | | |
| 11 | X 1900075736 | • • PG-RING | 1 | | | | |
| 12 | 1900075707 | • TUBE | 1 | | | | |
| 13 | 1900075701 | • ROD, piston | 1 | | | | |
| 14 | 1900075706 | • PISTON | 1 | | | | |
| 15 | 1900075755 | • HOLDER, packing | 1 | | | | |
| 16 | 1900075725 | • CUSHION, rod | 1 | | | | |
| 17 | 1900075731 | • RING, seal | 1 | | | | |
| 18 | 1900075719 | • STOPPER | 1 | | | | |
| 19 | 1900075714 | • RING, stop | 1 | | | | |
| 20 | 1900059627 | • RING, seal | 1 | | | | |
| 21 | 1900059629 | • STOPPER | 1 | | | | |
| 22 | 1900059615 | • RING, stop | 1 | | | | |
| 23 | 1900075702 | • BUSHING | 1 | | | | |
| 24 | 1900075720 | • BUSHING | 1 | | | | |
| 25 | 1333005030 | • BUSHING | 1 | | | | |
| 26 | 1560001900 | • FITTING, grease | 1 | | | | |
| 27 | 1900075729 | • ORIFICE | 1 | | | | |
| 28 | 1121050812 | • SET-SCREW | 1 | | | | |
| 29 | 1410810900 | • RING, wear | 2 | | | | |
| 30 | 1432200050 | • SEAL, dust | 4 | | | | |
| 31 | 1900075703 | • COVER, rod | 1 | | | | |
| 32 | 1900075704 | • RETAINER | 1 | | | | |
| | K3h161 | | | | | | |

BUCKET CYLINDER (for telescopic)

| Item | Part number | Description | Q'ty | Chan. | Serial No. | Serv. | Remarks |
|------|---------------------|-------------------|------|-------|------------|-------|---------|
| 0 | 1900047200 | CYLINDER ASSY | 1 | | | | bucket |
| 0-1 | 1900047295 | KIT, seal | 1 | | | | |
| 1 | X 1900005912 | PACKING, rod | 1 | | | | |
| 2 | X 1900047233 | SEAL, dust | 1 | | | | |
| 3 | X 1421120750 | RING, back-up | 1 | | | | |
| 4 | X 1420110750 | O-RING | 1 | | | | |
| 5 | X 1420100800 | O-RING | 1 | | | | |
| 6 | X 1900047231 | PACKING, piston | 1 | | | | |
| 7 | 1900047232 | ▪ RING, wear | 2 | | | | |
| 8 | 1900047207 | ▪ TUBE | 1 | | | | |
| 9 | 1900047202 | ▪ BUSHING | 2 | | | | |
| 10 | 1900047201 | ▪ ROD, piston | 1 | | | | |
| 11 | 1900047203 | ▪ COVER, rod | 1 | | | | |
| 12 | 1900047206 | ▪ PISTON | 1 | | | | |
| 13 | 1900047220 | ▪ WASHER | 1 | | | | |
| 14 | 1900047221 | ▪ SHIM | 1 | | | | |
| 15 | 1900047022 | ▪ BALL, steel | 1 | | | | |
| 16 | 1900047222 | ▪ SEAL, dust | 1 | | | | |
| 17 | 1333004525 | ▪ BUSHING | 1 | | | | |
| 18 | 1121000808 | ▪ SET-SCREW | 1 | | | | |
| 19 | 1560001000 | ▪ FITTING, grease | 1 | | | | |
| 20 | 1560001900 | ▪ FITTING, grease | 1 | | | | |
| | K3h191 | | | | | | |

TRAVEL MOTOR (1/3) (reduction sec. ; 14510004-14515345)

| Item | Part number | Description | Q'ty | Chan. | Serial No. | Serv. | Remarks |
|------|---------------------|--------------------|------|-------|-------------------|-------|---------|
| 0 | 1903119500 | MOTOR ASSY, travel | 1 | | 14510004~14512498 | | |
| | 1903123000 | MOTOR ASSY, travel | 1 | | 14512499~ | | |
| 0-1 | 1903119599 | · KIT, seal | 1 | | | | |
| 1 | X 1420300264 | · · O-RING | 1 | | | | |
| 2 | X 1420010140 | · · O-RING | 2 | | | | |
| 3 | X 1420010080 | · · O-RING | 1 | | | | |
| 4 | X 1420010110 | · · O-RING | 2 | | | | |
| 0-2 | 1903119598 | · KIT, body | 1 | | | | |
| 5 | 1903119519 | · · BEARING | 2 | | | | |
| 6 | 1903119524 | · · RING, snap | 1 | | | | |
| 0-3 | 1903119597 | · KIT, carrier1 | 1 | | | | |
| 7 | 1213000632 | · · PIN, spring | 4 | | | | |
| 0-4 | 1903119596 | · KIT, carrier2 | 1 | | | | |
| 8 | 1220000035 | · · RING, snap | 4 | | | | |
| 9 | 1213000532 | · · PIN, spring | 3 | | | | |
| 0-5 | 1903904600 | · MOTOR, hydraulic | 1 | | 14510004~14512498 | | |
| | 1903906500 | · MOTOR, hydraulic | 1 | | 14512499~ | | |
| 10 | 1903119502 | · COVER | 1 | | | | |
| 11 | 1903119509 | · GEAR | 1 | | | | |
| 12 | 1903119513 | · RING, snap | 1 | | | | |
| 13 | 1903118915 | · WASHER | 1 | | | | |
| 14 | 1903118916 | · RING | 1 | | | | |
| 15 | 1903118917 | · SEAL, floating | 2 | | | | |
| 16 | 1903119523 | · RING, snap | 1 | | | | |
| 17 | 1903118932 | · PLUG | 2 | | | | |
| 18 | 1903118993 | · PLUG | 1 | | | | |
| 19 | 1903901930 | · PLUG | 2 | | | | |
| | K3h233 | | | | | | |

TRAVEL MOTOR (3/3) (valve sec. ; 14515346-)

| Item | Part number | Description | Q'ty | Chan. | Serial No. | Serv. | Remarks |
|------|-------------------|--------------------|------|-------|------------|-------|---------|
| 0 | 1903124800 | MOTOR ASSY, travel | 1 | | | | |
| 0-7 | X ***** | ▪ BODY ASSY | 1 | | | | |
| 0-8 | 1903907393 | ▪ ▪ KIT, seal | 1 | | | | |
| 1 | 1420010080 | ▪ ▪ ▪ O-RING | 2 | | | | |
| 2 | 1420000125 | ▪ ▪ ▪ O-RING | 2 | | | | |
| 3 | 1420010140 | ▪ ▪ ▪ O-RING | 2 | | | | |
| 4 | 1420010250 | ▪ ▪ ▪ O-RING | 2 | | | | |
| | K3h470 | | | | | | |

SLEW MOTOR (1/2) (reduction sec. ; 14513261-)

| Item | Part number | Description | Q'ty | Chan. | Serial No. | Serv. | Remarks |
|------|---------------------|--------------------|------|-------|------------|-------|--------------|
| 0 | 1903122000 | MOTOR ASSY, slew | 1 | | | | |
| 0-1 | X ***** | • GEAR, reduction | 1 | | | | X19129-07700 |
| 0-2 | 1912907799 | • • KIT, seal | 1 | | | | |
| 1 | X 1420010080 | • • • O-RING | 1 | | | | |
| 2 | X 1420300260 | • • • O-RING | 1 | | | | |
| 3 | 1912907798 | • • HOUSING ASSY | 1 | | | | |
| 4 | 1912907011 | • • HOLDER | 1 | | | | |
| 5 | 1912905415 | • • LACE, inner | 4 | | | | |
| 6 | 1912905416 | • • BEARING | 4 | | | | |
| 7 | 1912904517 | • • GEAR | 4 | | | | |
| 8 | 1912907015 | • • PLATE, thrust | 1 | | | | |
| 9 | 1912900714 | • • SCREW | 4 | | | | |
| 10 | 1912906009 | • • GEAR | 1 | | | | |
| 11 | 1220000042 | • • RING, snap | 1 | | | | |
| 12 | 1912907019 | • • HOLDER | 1 | | | | |
| 13 | 1912907020 | • • WASHER, thrust | 3 | | | | |
| 14 | 1912900720 | • • LACE, inner | 3 | | | | |
| 15 | 1912905422 | • • CAGE&ROLLER | 3 | | | | |
| 16 | 1912907023 | • • GEAR | 3 | | | | |
| 17 | 1912907097 | • • PLATE, thrust | 1 | | | | |
| 18 | 1912907025 | • • GEAR | 1 | | | | |
| 19 | 1110041230 | • SCREW, cap | 2 | | | | |
| 20 | 1903119920 | • VALVE ASSY | 1 | | | | |
| 21 | 1420010100 | • O-RING | 3 | | | | |
| 22 | 1110040820 | • SCREW, cap | 3 | | | | |
| | K3h263 | | | | | | |

HYDRAULIC PUMP (3/3) (14512094-)

| Item | Part number | Description | Q'ty | Chan. | Serial No. | Serv. | Remarks |
|------|-------------------|-------------------------|------|-------|------------|-------|---------|
| 0 | 1902017000 | PUMP, hydraulic | 1 | | | | |
| 0-14 | 1902909300 | · PUMP ASSY, gear | 1 | | | | |
| 0-15 | 1902909398 | · · KIT, body | 1 | | | | |
| 1 | X ***** | · · · CASE | 1 | | | | |
| 2 | X ***** | · · · GEAR | 1 | | | | |
| 3 | X ***** | · · · GEAR | 1 | | | | |
| 4 | X ***** | · · · PLATE, side | 2 | | | | |
| 5 | X ***** | · · · PLATE | 2 | | | | |
| 6 | X ***** | · · · GUIDE | 2 | | | | |
| 0-16 | 1902907400 | · · PUMP ASSY, sub gear | 1 | | | | |
| 0-17 | 1902907498 | · · · KIT, body | 1 | | | | |
| 7 | X ***** | · · · · FRAME | 1 | | | | |
| 8 | X ***** | · · · · HOUSING | 1 | | | | |
| 9 | X ***** | · · · · GEAR | 1 | | | | |
| 10 | X ***** | · · · · GEAR | 1 | | | | |
| 11 | X ***** | · · · · PLATE, side | 1 | | | | |
| 12 | X ***** | · · · · METAL | 4 | | | | |
| 13 | 1902905907 | · · · RING, back-up | 1 | | | | |
| 14 | 1902900716 | · · · PIN | 2 | | | | |
| 15 | 1902905908 | · · · RING | 1 | | | | |
| 16 | 1902905909 | · · · RING | 1 | | | | |
| 17 | 1221000012 | · · · RING, snap | 1 | | | | |
| 18 | 1110020840 | · · · SCREW, cap | 4 | | | | |
| 19 | 1420300138 | · · · O-RING | 1 | | | | |
| 20 | 1902907212 | · · COUPLING | 1 | | | | |
| 21 | 1902907213 | · · BUSHING | 1 | | | | |
| 22 | 1902901612 | · · O-RING | 2 | | | | |
| 23 | 1420300014 | · · O-RING | 1 | | | | |
| 24 | 1902901611 | · · RING | 1 | | | | |
| 25 | 1902903714 | · · RING | 2 | | | | |
| 26 | 1100051090 | · · BOLT | 4 | | | | |
| 27 | 1110051025 | · · SCREW, cap | 2 | | | | |
| 28 | 1902900716 | · · PIN | 2 | | | | |
| 29 | 1420300018 | · · O-RING | 1 | | | | |
| 30 | 1420300023 | · · O-RING | 1 | | | | |
| 31 | 1420300128 | · · O-RING | 1 | | | | |
| 32 | 1420010100 | · · O-RING | 1 | | | | |
| 33 | 1902909399 | · KIT, seal | 1 | | | | |
| 34 | 1902905907 | · · RING, back-up | 1 | | | | |
| 35 | 1902905908 | · · RING | 1 | | | | |
| 36 | 1420300138 | · · O-RING | 1 | | | | |
| 37 | 1902901612 | · · O-RING | 2 | | | | |
| 38 | 1420300014 | · · O-RING | 1 | | | | |
| 39 | 1902901611 | · · RING | 1 | | | | |
| 40 | 1902903714 | · · RING | 2 | | | | |
| 41 | 1420300018 | · · O-RING | 1 | | | | |
| 42 | 1420300023 | · · O-RING | 1 | | | | |
| 43 | 1420300128 | · · O-RING | 1 | | | | |
| 44 | 1420010100 | · · O-RING | 1 | | | | |

K3h302

How to read this Parts Catalog.

1. Parts mentioned in this Parts Catalog may not necessarily be standard equipping parts.
2. Parts change may be made without prior notice.
3. Form of this Parts Catalog.

Y00F2161 (1997.09.01)

Fig. 29 燃料噴射ポンプ(ブーコン用)
FUEL INJECTION PUMP (W/BOOST)

| | | | |
|-------------|--|-------------|--|
| A= 4JH-DT | | D= 4JH-DTZA | |
| B= 4JH-DTZ | | E= 4JH-DTZY | |
| C= 4JH-DTZP | | F= | |

| 見出 REF.No. | レベル LEV. | 部品番号 PARTS No. | 部品名 | DESCRIPTION | 個数 (Qty) | | | | | | 備考 |
|--|-------------|-------------------|------------------|---------------------|----------|---|---|---|---|---|----|
| | | | | | A | B | C | D | E | F | |
| 1 | . | 729595-51390 | F0ポンプ ASY(7-コック) | FULE INJECTION PUMP | 1 | 1 | 1 | 1 | 1 | 1 | |
| 1-1 | . | 729595-51391 | F0ポンプ ASY(7-コック) | FULE INJECTION PUMP | 1 | 1 | 1 | 1 | 1 | 1 | |
| 3 | .. | 26022-060162 | ナメネジ M 6X 16 | SCREW M 6X 16 | 9 | 9 | 9 | 9 | 9 | 9 | |
| I 3-1 | .. | 26022-060162 | ナメネジ M 6X 16 | SCREW M 6X 16 | 4 | 4 | 4 | 4 | 4 | 4 | K |
| (A=E/#00185)(B=E/#00200)(C=E/#00156)(D=E/#00156)(E=E/#00156) | | | | | 1 | 1 | 1 | 1 | 1 | 1 | |
| 4 | .. | 129470-51040 | カムシャフト | CAMSHAFT | 1 | 1 | 1 | 1 | 1 | 1 | |
| 5 | .. | 122710-51050 | ベアリングローラ | BEARING, ROLLER | 2 | 2 | 2 | 2 | 2 | 2 | |
| 6 | .. | 129470-51060 | ベアリングオサヒ | RETAINER | 1 | 1 | 1 | 1 | 1 | 1 | |

| | |
|---|--|
| 備考 | Remarks |
| (1) ブーストコンペンセータ付き。4JH-DT, 4JH-DTZとも E/# 00155 までは、特別注文仕様とします | (1) BOOST COMPENSATOR TYPE. OPTIONAL PART, TO E/# 00155. (4JH - DT, 4JH - DTZ) |

① Ref. No.

The Ref. No. in the list may not be accord with the Ref. No. on illustration.
(Ex.) Illustration No. List head No.

1 1 (Befor change) → 1 -1 (After change)

When interchangeable symbol N, R, and K, illustrations for new parts are sometimes omitted.

② Lev.(Level)

Indication and Meaning of Level

Level : Hereunder is given the relation among the number of dots(•), the level and the nominal parent- child relationship.

-Parent parts(Assembly parts)
-Child parts included in "••" (Semi- Assembly parts, component parts of Assembly parts.)
-Child parts included in "•••", Grand- child parts in terms of "••".
(Compornent parts of Semi- Assembly parts.)

Note) A parts of non- sale parts are illustlated but not listed.

③ Change Mark

Change Mark "I" is given to the part for which a desigh change was made at this time.
The design change was not shown in the last published Parts Catalog.

④ Interchangeability Mark

In the case where a part change took place, one of the following interchangeability marks is indicated for that part.

| Symbol | interchangeability | Contents note |
|--------|-------------------------------|--|
| N | Old \longleftrightarrow New | New Part is interchangeable for Old Part but not interchangeable conversely. |
| Q | Old \longleftrightarrow New | New Part is not interchangeable for Old Part but interchangeable conversely. |
| R | Old \longleftrightarrow New | New Part is interchangeable for Old Part and vice versa. |
| S | Old \longleftrightarrow New | New Part is not interchangeable for Old Part and vice versa. |
| W | | Part newly added. |
| Z | | Part discontinued. |
| F | | Not interchangeable single part but interchangeable by set of the related parts. |
| K | | Changed only in quantity used. |

⑤ Effective Machine No.

When a part is changed, Effective Machine No. of a Model for which the part is applicable is indication in each column of (A)- (F).

| Product Symbol | Product No. | Product Symbol | Product No. |
|----------------|---------------------------|----------------|-------------|
| C | Clutch No. Compressor No. | M | Machine No. |
| D | Drive No. | T | Tractor No. |
| E | Engine No. | Note1) ※ | Date |

Note1) Date may follow the symbol in some cases. (Ex.) ※ 1996.01

Note2) As far as engine models shown by "XXX" are concerned, the modification of the parts could not be predicted or the engine models themselves could not be identified.

Note3) (A=E/#00185) means that the design change on the part has been effective for the model at the column (A)(in this case, for 4JH- DT) on and from E/(Engine Serial Number) 00185.

⑥ Remarks Mark

Figures or alphabets (Symbols) are entered in the remark column.

The comments(remarks)on the pertinent parts are indicated in the lower part of the list by the same symbols as those stated above.

¼ØÝÁÞÍÄÄ & ÍÞÝËÄÄ CYLINDER HEAD & BONNET

| REF NO. | PARTS NO. | Description | Q'ty | I | R | "ó |
|---------|---------------|-----------------------|------|---|---|----------------|
| 1 | Y171350-03090 | PIPE, BREATHER | 1 | | | |
| 2 | Y124736-07900 | LIFTER, ENGINE | 2 | | | |
| 3 | Y26106-080142 | BOLT M 8X 14 PLATED | 4 | | | |
| 4 | Y129407-11700 | HEAD ASSY, CYLINDER | 1 | | | |
| 8 | Y120130-11860 | • GUIDE, VALVE | 4 | | | (1) ÍÖ³ÍÞËÝÄÞ½ |
| 10 | Y129150-11810 | • GUIDE, VALVE | 4 | | | (1) ÍÖ³ÍÞËÝÄÞ½ |
| 12 | Y26216-060202 | • STUD M 6X 20 PLATED | 8 | | | |
| 13 | Y27241-400000 | • PLUG 40 | 2 | | | |
| 14 | Y129100-11100 | • VALVE, INTAKE | 4 | | | |
| 15 | Y129100-11110 | • VALVE, EXHAUST | 4 | | | |
| 16 | Y129795-11120 | • SPRING, VALVE | 8 | | | |
| 17 | Y129795-11180 | • RETAINER, SPRING | 8 | | | |
| 18 | Y27310-080000 | • COTTER | 8 | | | |
| 19 | Y121400-11340 | • SEAL, VALVE STEM | 4 | | | |
| 20 | Y124460-11340 | • SEAL, VALVE STEM | 4 | | | |
| 21 | Y129150-11370 | • CAP, VALVE | 8 | | | |
| 22 | Y119625-11900 | • RETAINER | 4 | | | |
| 23 | Y119625-11880 | • SEAT, NOZZLE | 4 | | | |
| 24 | Y119625-11870 | • PROTECTOR, NOZZLE | 4 | | | |
| 25 | Y22351-060012 | SPRING PIN 6X12 | 2 | | | |
| 26 | Y26366-060002 | NUT M 6 | 8 | | | |
| 27 | Y129500-11240 | SHAFT, ROCKER ARM | 1 | | | |
| 28 | Y129155-11260 | • SUPPORT, ROCKER ARM | 2 | | | |
| 29 | Y129155-11270 | • SUPPORT, ROCKER ARM | 3 | | | |
| 30 | Y129150-11280 | • SPRING | 4 | | | |
| 31 | Y129550-11290 | • SHAFT, ROCKER ARM | 1 | | | |
| 34 | Y129100-11650 | • ARM ASSY, ROCKER | 8 | | | |
| 35 | Y129150-11230 | • SCREW, VALVE | 8 | | | |
| 37 | Y129150-11750 | • NUT M8XP1.0 | 8 | | | |
| 38 | Y26226-080182 | • STUD M 8X 18 PLATED | 3 | | | |
| 38- 1 | Y119802-11280 | • STUD | 3 | | R | |
| | (ALL=EXXX) | | | | | |
| 39 | Y26756-080002 | • LOCK NUT M 8 PLATED | 3 | | | |
| 40 | Y26106-080252 | BOLT M 8X 25 PLATED | 3 | | | |
| 41 | Y26106-080502 | BOLT M 8X 50 PLATED | 7 | | | |
| 42 | Y129400-11350 | BONNET ASSY | 1 | | | |
| 43 | Y124160-01751 | • COVER, FILLER | 1 | | | |
| 44 | Y129150-03020 | • COVER, BREATHER | 1 | | | |
| 45 | Y129150-03070 | • BAFFLE, BREATHER | 1 | | | |
| 46 | Y129150-03080 | • PLATE, SHELTER | 1 | | | |
| 49 | Y129550-11310 | • GASKET, BONNET | 1 | | | |
| 50 | Y24311-000320 | • O-RING 1A P-32.0 | 1 | | | |
| 51 | Y24341-000500 | • O-RING 1A S-50.0 | 1 | | | |
| 52 | Y26106-080162 | • BOLT M 8X 16 PLATED | 2 | | | |
| 61 | Y124160-11360 | KNOB | 3 | | | |
| 62 | Y24311-000120 | O-RING 1A P 12.0 | 3 | | | |

LO-OIL SYSTEM

| REF NO. | PARTS NO. | Description | Q'ty | | |
|---------|--|-----------------------|------|---|--|
| 1 | Y129407-32000 | LO-P CMP | 1 | | |
| 14 | Y129150-32020 | PK(LO-P | 1 | | |
| 15 | Y26450-060252 | 6X 25 | 4 | | |
| 16 | Y129150-35041 | PK(ON-ASB.) | 1 | | |
| 17 | Y129150-35091 | LO-OIL INLET | 1 | | |
| 17- 1 | Y129436-35091 (TB=E38541) | LO-OIL CMP | 1 | N | |
| 21 | Y26106-080352 | BOLT M 8X 35 PLATED | 2 | | |
| 22 | Y129150-35101 | BRACKET, STRAINER | 1 | | |
| 23 | Y129150-35111 | GASKET, (NON-ASB.) | 1 | | |
| 24 | Y129150-35152 | FILTER 80X80L | 1 | | |
| 25 | Y129001-35300 | BOLT, LUB.O. STRAINER | 1 | | |
| 26 | Y129150-35350 | NUT | 1 | | |
| 27 | Y24311-000160 | O-RING 1A P-16.0 | 1 | | |
| 28 | Y26106-080202 | BOLT M 8X 20 PLATED | 3 | | |
| 29 | Y124160-39451 | SWITCH, OIL PRESSURE | 1 | | |
| 29- 1 | Y124160-39450 (TB=E36807) | SWITCH, OIL PRESSURE | 1 | N | |
| 29- 2 | Y114250-39450 (TB=E39207 TB1=*1999.12) (ETB=E47698 ETB1=50273) | SWITCH,(0.5KG)L.O. | 1 | N | |
| 30 | Y124160-39140 | BOLT 10, PIPE JOINT | 1 | | |
| 31 | Y129550-39450 | PIPE ASSY, LUB. OIL | 1 | | |
| 35 | Y124550-59830 (TB=E38541) | BOLT W/ SEAL WASHER | 1 | W | |
| 36 | Y124550-59820 | BOLT 8, PIPE JOINT | 1 | | |
| 37 | Y22190-080002 | SEAL WASHER 8S | 2 | | |
| 37- 1 | Y22190-080002 (TB=E38541) | SEAL WASHER 8S | 1 | K | |
| 38 | Y23414-100000 | GASKET 10, ROUND | 2 | | |
| 38- 1 | Y22190-100002 (TB=E39207 TB1=*1999.10) (ETB=E45989 ETB1=46180) | SEAL WASHER 10S | 2 | N | |
| 39 | Y171420-34800 | DIPSTICK | 1 | | |
| 39- 1 | Y171420-34820 (TB=E38541) | DIPSTICK, LUB. OIL | 1 | N | |
| 40 | Y121520-34810 | GUIDE, DIPSTICK | 1 | | |
| 41 | Y22190-080002 (TB=E38541) | SEAL WASHER 8S | 1 | W | |

| REF NO. | PARTS NO. | GOVERNOR | Description | Q'ty | I | R | Q'ty |
|---------|---|------------------------|-------------------------|------|---|---|------------------------|
| 2 | Y129155-51280 | • OØÝ, Þ(S6 | • O-RING S6 | 1 | | | |
| 5 | Y129052-61050 | • ÉßÄ·Ý (¶ÞÉÞÄ¹·½ | • PACKING | 1 | | | |
| 6 | Y129052-61060 | • ¶ÞÉÞÄ¹·½Ä | • COVER | 1 | | | |
| 7 | Y129052-61070 | • ÉßÄ·Ý (¹·½Ä | • PACKING | 1 | | | |
| 8 | Y129155-61120 | • ØÝ, L=30(İ-, 0 | • LINK L=30(MARK 0 | 1 | | | (1) ¾ÝÄ, ¼Ä, ¼Ä·ÍÞÄ, 0 |
| 9 | Y129155-61130 | • ØÝ, L=31(İ-, 1 | • LINK L=31(MARK 1 | 1 | | | (1) ¾ÝÄ, ¼Ä, ¼Ä·ÍÞÄ, 0 |
| 10 | Y129155-61140 | • ØÝ, L=30.5 (İ-, 05) | • LINK L=30.5(MARK 05) | 1 | | | (1) ¾ÝÄ, ¼Ä, ¼Ä·ÍÞÄ, 0 |
| 11 | Y129155-61201 | • ¶ÞÉÞÄ³·²Ä CMP | • WEIGHT ASSY, GOVERNOR | 1 | | | (2x ½Ä » |
| 11-1 | Y129486-61200 | • ¶ÞÉÞÄ³·²Ä CMP | • WEIGHT ASSY, GOVERNOR | 1 | S | | ¾ÝÄ, ¼Ä, ¼Ä·ÍÞÄ, 0 |
| 11-2 | (ETB=E45989 ETB1=E46180) Y129155-61202 | • ¶ÞÉÞÄ³·²Ä CMP | • WEIGHT ASSY, GOVERNOR | 1 | R | | ¾ÝÄ, ¼Ä, ¼Ä·ÍÞÄ, 0 |
| 11-3 | (TB=E39207 TB1=*2000.01) Y129486-61201 | • ¶ÞÉÞÄ³·²Ä CMP | • WEIGHT ASSY, GOVERNOR | 1 | R | | ¾ÝÄ, ¼Ä, ¼Ä·ÍÞÄ, 0 |
| 15 | Y129155-61341 | • ½Ø-ÌÞ | • SLEEVE | 1 | | | (2) ¾ÝÄ, ¼Ä |
| 16 | Y129100-61400 | • 0ÝÄÛ-ÛÛÉÞ¼Þ, CMP | • SHAFT ASSY, CONTROL | 1 | | | |
| 19 | Y129155-61430 | • ¶Ý»Þ(0ÝÄÛ-ÛÛÉÞ ¼Þ, | • SPACER, SHAFT | 1 | | | |
| 23 | Y129155-61450 | • ¶²ÄÝ¾²¹ÞÝÍÞÛÄ | • BOLT, REVOL. LIMIT | 1 | | | |
| 24 | Y129155-61460 | • ±²ÄÞÛ¾²¹ÞÝÍÞÛÄ | • BOLT, IDLE LIMIT | 1 | | | |
| 25 | Y129155-61480 | • ¶Ý»Þ COMP | • SPACER ASSY | 2 | | | |
| 30 | Y129052-61390 | • ¼ÛÄ(¶ÞÉÞÄÛÉÞ | • SHAFT, GOV. LEVER | 1 | | | |
| 31 | Y129052-61500 | • ¶ÞÉÞÄÛÉÞ- CMP | • LEVER ASSY, GOVERNOR | 1 | | | |
| 31-1 | Y119908-61501 | • ¶ÞÉÞÄÛÉÞ- CMP | • LEVER ASSY, GOVERNOR | 1 | R | | |
| 32 | 174307-51700 | • ¼Ñ¾ÄÄ(ÄÛ¾²Û³ | • SHIM SET | 2 | | | |
| 46 | 129052-61540 | • ¾ÄÄ½ÍßØÝ, Þ(GÛÉÞ- | • SPRING | 1 | | | |
| 46-1 | 129486-61540 | • ¾ÄÄ½ÍßØÝ, Þ | • SPRING, SET | 1 | S | | |
| 56 | 119660-61901 | • Ç¹ÄÞÛ | • RETAINER, SHAFT | 1 | | | |
| 57 | 129155-61950 | • »ÞÄ· B(Ì³²Ý | • BOLT, WASHER BASED | 1 | | | |
| 58 | 124550-66370 | • ÄÛÄÄÄ 6 (ÄÄÞØ±Ä | • LOCK NUT M 6 | 1 | | | |
| 58-1 | 129209-61370 | • ÄÄÄ(ARB | • NUT M6 | 1 | S | | |
| 59 | 22117-040000 | • »Þ¶ÞÉ(0ÛÛ 4 | • WASHER 4 | 1 | | | |
| 60 | 22190-060002 | • ¼-ÛÛÄ¼ÛÛ(0ÛÛ·ÆÄØÛ) 6 | • SEAL WASHER 6S | 1 | | | |
| 60-1 | 22190-060003 | • ¼-ÛÛÄ¼ÛÛ(ÛÛ 6 | • WASHER, SEAL 6 | 1 | N | | |
| 61 | 22190-100002 | • ¼-ÛÛÄ¼ÛÛ(0ÛÛ·ÆÄØÛ)10 | • SEAL WASHER 10S | 1 | | | |
| 62 | 22190-120002 | • ¼-ÛÛÄ¼ÛÛ(0ÛÛ 12 | • SEAL WASHER 12 | 2 | | | |
| 63 | 22287-120000 | • ½-Éß-ÛÄ, »Þ¶ÞÉ 12 | • WASHER 12 | 1 | | | |
| 64 | 22372-040000 | • ½ÄÄÍßÉßÝJASO 4 | • SNAP PIN 4 | 2 | | | |

½Ä-Ä²Ý, ÞÓ-Ä STARTING MOTOR

| REF NO. | PARTS NO. | Description | Q'ty | I | R | ø |
|---------|------------------------------|--------------------------|------|---|---|---|
| 1 | Y129400-77012 | STARTING MOTOR | 1 | | | |
| 1- 1 | Y129136-77011 (TB=E38009) | STARTER | 1 | S | | |
| 2 | Y129486-77400 | • ARMATUER | 1 | | | |
| 2- 1 | Y129900-77400 (TB=E38009) | • ARMATURE ASSY | 1 | S | | |
| 3 | Y171008-77410 (TB=E38009) | • • BEARING(1) | 1 | Z | | |
| 4 | Y171008-77420 (TB=E38009) | • • BEARING(2) | 1 | Z | | |
| 5 | Y129400-77441 | • FIELD COIL ASSY | 1 | | | |
| 5- 1 | Y129900-77440 (TB=E38009) | • COIL ASSY, FIELD | 1 | S | | |
| 6 | Y129486-77460 | • • BRUSH | 2 | | | |
| 6- 1 | Y129900-77450 (TB=E38009) | • • BRUSH (+) | 2 | S | | |
| 6A | Y171008-77450 (TB=E38009) | • • SCREW, POLE CORE SET | 4 | W | | |
| 7 | Y129486-77470 | • HOLDER ASSY, BRUSH | 1 | | | |
| 7- 1 | Y129900-77480 (TB=E38009) | • HOLDER ASSY, BRASH | 1 | S | | |
| 8 | Y129486-77460 | • • BRUSH | 2 | | | |
| 8- 1 | Y129900-77500 (TB=E38009) | • • BRUSH (-) | 2 | S | | |
| 9 | Y129486-77490 (TB=E38009) | • • SPRING, START BRUSH | 4 | Z | | |
| 10 | Y129900-77460 | • COVER, REAR | 1 | | | |
| 11 | Y171008-77510 | • HOUSING ASSY, GEAR | 1 | | | |
| 12 | Y129400-77520 | • HOUSING, CENTER | 1 | | | |
| 12- 1 | Y129136-77520 (TB=E38009) | • CENTER HOUSING | 1 | S | | |
| 13 | Y129400-77531 | • SWITCH ASSY, MAGNETIC | 1 | | | |
| 13- 1 | Y129136-77310 (TB=E38009) | • SHAFT, PINION | 1 | S | | |
| 14 | Y171008-77540 | • LEVER SET, SHIFT | 1 | | | |
| 17 | Y129400-77571 | • DUST COVER, (NON-ASB. | 1 | | | |
| 18 | Y129900-77640 | • BOLT, THROUGH | 2 | | | |
| 19 | Y171008-77650 | • PINION ASSY | 1 | | | |
| 20 | Y171008-77660 | • • SHAFT, PINION | 1 | | | |
| 21 | Y171008-77670 | • • STOPPER SET, PINION | 1 | | | |
| 25 | YX2114555500 | • • CLUTCH ASSY | 1 | | | |
| 26 | YX2114955020 | • • • BALL BEARING | 1 | | | |
| 27 | YX2240410100 | • • • BALL BEARING | 1 | | | |
| 28 | Y26106-060322 | • BOLT M 6X 32 PLATED | 2 | | | |
| 29 | Y26106-060402 | • BOLT M 6X 40 PLATED | 3 | | | |
| 30 | Y26116-120252 | BOLT M12X 25 PLATED | 2 | | | |
| 31 | Y124550-77030 | COVER, TERMINAL | 1 | | | |

·Ö³·ĪÆĪ-ŪÄÞ & '±,Ø-Ä SUCTION MANIFOLD & AIR CLEANER

| REF NO. | PARTS NO. | Description | Qty | I | R | ö |
|---------|---------------|-----------------------|-----|---|---|---|
| 1 | Y129407-12100 | MAINFOLD,INTAKE | 1 | | | |
| 3 | Y129407-12110 | GASKET,INT.MANOFOLD | 1 | | | |
| 4 | Y26106-080202 | BOLT M 8X 20 PLATED | 6 | | | |
| 5 | Y26106-080802 | BOLT M 8X 80 PLATED | 1 | | | |
| 6 | Y119910-12210 | PIPE,INTAKE | 1 | | | |
| 7 | Y119910-12560 | BRACKET,AIRCLEANER | 1 | | | |
| 8 | Y23000-060000 | CLAMP 60 | 2 | | | |
| 8- 1 | Y23000-060000 | CLAMP 60 | 6 | K | | |
| 8- 2 | Y23000-060000 | CLAMP 60 | 5 | K | | |
| 9 | Y26013-080222 | BOLT M 8X 22 | 4 | | | |
| 10 | Y26013-080222 | BOLT M 8X 22 | 2 | | | |
| 11 | Y129100-77500 | HEATER, AIR | 1 | | | |
| 12 | Y129100-77510 | GASKET, AIR HEATER | 1 | | | |
| 13 | Y129150-77511 | GASKET, (NON-ASB.) | 1 | | | |
| 14 | Y171340-77520 | BEND | 1 | | | |
| 15 | Y26106-080402 | BOLT M 8X 40 PLATED | 2 | | | |
| 16 | Y26106-080802 | BOLT M 8X 80 PLATED | 2 | | | |
| 17 | Y121855-12060 | SILENCER,INLET | 1 | W | | |
| 18 | Y119883-12210 | HOSE, AIR INTAKE | 1 | W | | |
| 19 | Y23000-060000 | CLAMP 60 | 2 | | | |
| 20 | Y129612-12680 | AIR CLEANER | 1 | | | |
| 20- 1 | Y129612-12681 | CLEANER ASSY, AIR | 1 | N | | |
| 21 | Y129612-12560 | · RING | 1 | | | |
| 22 | Y23000-060000 | · CLAMP 60 | 1 | | | |
| 23 | Y129612-12690 | · CLEANER ASSY, AIR | 1 | | | |
| 23- 1 | Y129612-12691 | · CLEANER ASSY, AIR | 1 | N | | |
| 24 | Y119910-12510 | · · BODY, AIR CLEANER | 1 | | | |
| 25 | Y119808-12520 | · · ELEMENT, OUTER | 1 | | | |
| 26 | Y119866-12541 | · · COVER ASSY | 1 | | | |
| 27 | Y119808-12540 | · · VALVE, UNLOADER | 1 | | | |
| 28 | Y119140-12680 | · · INDICATOR | 1 | | | |
| 28- 1 | Y129953-12620 | · · INDICATOR ASSY | 1 | N | | |
| 29 | Y129259-12570 | · · RING | 1 | | | |
| 30 | Y129612-12241 | PIPE, EXTENSION | 1 | W | | |

CW¼½ÄÑ COOLING WATER SYSTEM

| REF NO. | PARTS NO. | Description | Q'ty | I | R | ö |
|---------|---------------|----------------------|------|---|---|---|
| 1 | Y121750-49110 | JOINT | 1 | | | |
| 2 | Y129001-42002 | PUMP ASSY, C.WATER | 1 | | | |
| 2- 1 | Y129001-42003 | PUMP ASSY,COOLANT | 1 | N | | |
| 13 | Y23871-030000 | • PLUG PT3/8,SCREW | 2 | | | |
| 13- 1 | Y23876-030000 | • PLUG PT3/8,SCREW | 2 | N | | |
| 14 | Y26106-080602 | BOLT M 8X 60 PLATED | 3 | | | |
| 15 | Y25132-003900 | V-BELT (A-39) | 1 | | | |
| 16 | Y129403-42380 | V-PULLEY(D=110) | 1 | | | |
| 17 | Y129436-44740 | FAN,COOLING | 1 | | | |
| 18 | Y121267-44760 | SPACER | 1 | | | |
| 19 | Y26014-060302 | BOLT W/WASHER 6X 30 | 4 | | | |
| 20 | Y129350-49560 | COVER, THERMOSTAT | 1 | | | |
| 21 | Y129795-49551 | GASKET, (NON-ASB.) | 1 | | | |
| 22 | Y129155-49800 | THERMOSTAT | 1 | | | |
| 23 | Y129150-49811 | GASKET, (NON-ASB.) | 1 | | | |
| 24 | Y129100-49840 | GASKET, THERMO. CASE | 1 | | | |
| 24- 1 | Y124395-49840 | GASKET, THERMO. CASE | 1 | N | | |
| 25 | Y26106-080202 | BOLT M 8X 20 PLATED | 2 | | | |
| 26 | Y121250-44901 | SWITCH, THERMO(110&C | 1 | | | |
| 27 | Y124465-44950 | GASKET 16 | 1 | | | |
| 28 | Y129150-49360 | GASKET 10 | 1 | | | |
| 29 | Y129001-42040 | JOINT | 1 | | | |
| 30 | Y24321-000300 | O-RING G30 | 1 | | | |
| 30- 1 | Y129486-42140 | O-RING,CW-P | 1 | N | | |
| 31 | Y26106-080162 | BOLT M 8X 16 PLATED | 3 | | | |
| 32 | Y119266-49350 | SENSOR, THERMO. | 1 | | | |
| 33 | Y129100-42020 | GASKET, C.W. PUMP | 1 | | | |
| 33- 1 | Y129486-42021 | GASKET | 1 | N | | |
| 34 | Y171064-44510 | SUB-TANK ASSY | 1 | | | |
| 36 | Y121450-44531 | • CAP | 1 | | | |
| 37 | Y124450-44560 | • CLAMP | 1 | | | |
| 38 | Y121470-44581 | • GASKET | 1 | | | |
| 39 | Y23065-070225 | • HOSE 7X 225 | 1 | | | |
| 40 | Y124450-44550 | CLAMP, SUB-TANK | 1 | | | |
| 41 | Y121256-44600 | BRACKET, SUB-TANK | 1 | | | |
| 42 | Y23010-038000 | CLAMP 38 | 4 | | | |
| 42- 1 | Y23010-038000 | CLAMP 38 | 2 | K | | |
| 43 | Y129150-49100 | COCK ASSY, 3-WAY | 1 | | | |
| 44 | Y129150-49080 | • COCK, DRAIN | 1 | | | |
| 48 | Y119032-44502 | RADIATOR | 1 | | | |
| 49 | Y119032-44660 | • CAP ASSY | 1 | | | |
| 49A | YX0227108012 | • FAN SHURAUD | 1 | W | | |
| 50 | Y23010-050000 | CLAMP 50 | 2 | W | | |
| 51 | Y171091-44900 | COOLER,OIL | 1 | | | |
| 52 | Y129612-49010 | PIPE(A), C. WATER | 1 | | | |
| 53 | Y129612-49020 | PIPE(B), C. WATER | 1 | | | |
| 53- 1 | Y129612-49021 | PIPE, C.W. | 1 | N | | |
| 54 | Y119032-44591 | NET, WIRE | 1 | Z | | |

FOËËË FUEL LINE

| REF NO. | PARTS NO. | Description | Q'ty | I | R | δ |
|---------|---------------|-----------------------|------|---|---|---|
| 1 | Y129052-55620 | STRAINER ASSY, FUEL | 1 | | | |
| 2 | Y104200-55321 | • VALVE, TAPER | 1 | | | |
| 3 | Y104200-55330 | • SPRING, TAPER VALVE | 1 | | | |
| 4 | Y129100-55650 | • ELEMENT, FUEL | 1 | | | |
| 6 | Y129100-55670 | • LEVER | 1 | | | |
| 7 | Y129100-55680 | • CUP, STRAINER | 1 | | | |
| 8 | Y129100-55690 | • RING, RETAINING | 1 | | | |
| 9 | Y129100-55700 | • SPRING | 1 | | | |
| 10 | Y104200-55750 | • SCREW M 4 | 1 | | | |
| 11 | Y24311-000160 | • O-RING 1A P-16.0 | 1 | | | |
| 12 | Y24311-240100 | • O-RING 1A P-10A | 1 | | | |
| 13 | Y24321-000650 | • O-RING 1A G-65.0 | 1 | | | |
| 14 | Y26014-080702 | BOLT W/WASHER M8X 70 | 1 | | | |
| 15 | Y103854-39140 | BOLT, PIPE JOINT | 1 | | | |
| 16 | Y101304-59020 | JOINT 12, PIPE | 1 | | | |
| 17 | Y129210-59040 | PIPE ASSY, FUEL OIL | 1 | | | |
| 18 | Y124766-59050 | • CLAMP 12 | 2 | | | |
| 19 | Y129555-59510 | • PIPE, FUEL | 1 | | | |
| 20 | Y22190-120002 | SEAL WASHER 12 | 2 | | | |
| 21 | Y129335-55700 | SEPARATOR, WATER | 1 | | | |
| 22 | Y104200-55321 | • VALVE, TAPER | 1 | | | |
| 23 | Y104200-55330 | • SPRING, TAPER VALVE | 1 | | | |
| 24 | Y104200-55341 | • HANDLE, COCK | 1 | | | |
| 25 | Y124064-55510 | • BOWL, FUEL STRAINER | 1 | | | |
| 26 | Y102103-55520 | • O-RING | 1 | | | |
| 27 | Y110250-55610 | • RING, RETAINING | 1 | | | |
| 28 | Y121257-55720 | • SPRING, SCREEN | 1 | | | |
| 29 | Y121257-55731 | • FLOAT | 1 | | | |
| 31 | Y101720-55750 | • PLUG 6 | 2 | | | |
| 32 | Y104200-55750 | • SCREW M 4 | 1 | | | |
| 33 | Y171081-55910 | • SCREEN | 1 | | | |
| 34 | Y23418-060000 | • GASKET 6, NYLON | 2 | | | |
| 35 | Y24311-240100 | • O-RING 1A P-10A | 1 | | | |
| 36 | Y129322-77401 | FEED PUMP | 1 | | | |
| 37 | Y124066-59100 | CLAMP 8 | 1 | | | |
| 38 | Y129150-59580 | CAP | 1 | | | |
| 39 | Y119840-59601 | BEND ASSY | 1 | | | |
| 39- 1 | Y119840-59601 | BEND ASSY | 2 | | | K |
| 40 | Y124766-59050 | • CLAMP 12 | 2 | | | |
| 40- 1 | Y124766-59050 | • CLAMP 12 | 4 | | | K |

¼ØÝÀÞÌÞÙ, CYLINDER BLOCK

| REF NO. | PARTS NO. | Description | Q'ty | I | R | Notes |
|---------|---------------|-----------------------|------|---|---|-------------------------|
| 1 | Y729602-01560 | ¼ØÝÀÞÌÞÙ, ASSY | 1 | | | |
| 5 | Y124160-01910 | • Ìß×, Þ PT1/4 | 2 | | | |
| 6 | Y171051-01921 | • Ìß×, Þ NPTF1 | 1 | | | |
| 7 | Y129150-02020 | • ÍÞÙÄ(ÒÀÙ-ÒÄÌß | 10 | | | |
| 10 | Y124060-01050 | • Ìß×, Þ | 1 | | | |
| 11 | Y129001-01250 | • »×¶ÍÞÄÌß×, Þ 50 | 1 | | | |
| 12 | Y27241-120000 | • ÙÝ¶ÍÞÄÌß×, Þ 12 | 2 | | | |
| 13 | Y27241-300000 | • ÙÝ¶ÍÞÄÌß×, Þ 30 | 8 | | | |
| 14 | Y129795-02411 | • ÌÞÄ¼Ö (A) | 1 | | | |
| 15 | Y124160-01910 | • Ìß×, Þ PT1/4 | 1 | | | |
| 25 | Y129001-02930 | • Ò²ÝÒÄÙCMP(STDÎÖ³ËÝ) | 5 | | | (3) ÎÖ³ÌÞËÝÄÞ½ |
| 28 | Y129150-02930 | • ½×½ÄÒÄÙ | 2 | | | |
| 31 | Y129150-01200 | ÍÄÄÞÌÞÙÄ | 18 | | | |
| 32 | Y129407-01340 | ÍÄÄÞ¶ÍÞ½'ÄÄ | 1 | | | |
| 33 | Y129004-01190 | Ä²»Þ²Ë½Íß-» | 1 | | | |
| 34 | Y129150-02870 | Ò²ÝÒÄÙ U.S=0.25 | 5 | | | (1) ±ÝÄÞ°»²½Þ(U.S=0.25 |
| 37 | Y129150-02940 | ½×½ÄÒÄÙ 0.25(2¹=1¼ÄÄ | 1 | | | (2) μ°ËÞ°»²½Þ(O.S=0.25) |

| REF NO. | PARTS NO. | Description | Q'ty | I | R | »ó |
|---------|---------------|-----------------------|------|---|---|----|
| 1 | Y129640-13109 | MANIFOLD, EXHAUST | 1 | | | |
| 2 | Y129550-13110 | GASKET, EXH.MANIFOLD | 1 | | | |
| 3 | Y26306-080002 | NUT | 2 | | | |
| 4 | Y123900-13630 | BOLT 8X80 | 6 | | | |
| 5 | Y119131-18320 | BOLT M 8X 22 | 4 | | | |
| 6 | Y123900-13610 | STUD BOLT M 8X 80 | 2 | | | |
| 8 | Y129642-13590 | CLAMP | 1 | | | |
| 10 | Y22117-100000 | • WASHER 10 | 1 | | | |
| 11 | Y22217-100000 | • SPRING WASHER 10 | 1 | | | |
| 12 | Y26106-100652 | • BOLT M10X 65 PLATED | 1 | | | |
| 13 | Y26706-100002 | • NUT M10 | 1 | | | |
| 14 | Y129930-13201 | GASKET, SILENCER | 1 | | | |
| 15 | Y129642-13520 | SILENCER | 1 | | | |
| 16 | Y26306-080002 | NUT | 4 | | | |
| 17 | Y26106-100202 | BOLT M10X 20 PLATED | 2 | | | |
| 18 | Y129642-13650 | PIPE, SILENCER | 1 | | | |

CW¼½ÄÑ COOLING WATER SYSTEM

| REF NO. | PARTS NO. | Description | Q'ty | I | R | »öll |
|--------------------------------|---------------|-----------------------|----------------------|---|---|------|
| 1 | Y129004-42001 | CWÍßÝÍß CMP | PUMP ASSY, WATER | 1 | | |
| 3 | Y129100-42051 | • PK(CW-P)(ÉÝ±½) | • GASKET, (NON-ASB.) | 1 | | |
| 4 | Y129100-42121 | • ÍßÚ-Ä | • PLATE | 1 | | |
| 8 | Y121850-42410 | • ½,ØÖ³ | • SCREW | 3 | | |
| 10 | Y119802-49113 | • CW-T Ä-ÞÄ | • JOINT | 2 | | |
| 11 | Y23876-010000 | • É¼ÞÍß×, ÞPT1/8 | • PLUG PT1/8, SCREW | 1 | | |
| 12 | Y23876-020000 | • É¼ÞÍß×, Þ 1/4 | • PLUG 1/4 | 1 | | |
| 13 | Y129916-49740 | • É¼ÞÍß×, Þ R03 | • PLUG, DRAIN R03 | 2 | | |
| 14 | Y129486-42021 | PK(CW-P) | GASKET | 1 | | |
| 15 | Y129004-42040 | ¼ÞÖ²ÝÄ(CW-P) | JOINT | 1 | | |
| 16 | Y129486-42140 | OØÝ, Þ G 30 | O-RING, CW-P | 1 | | |
| 17 | Y124395-49840 | PK(»-Ó½ÄÄÄ¹-½ | GASKET, THERMO. CASE | 1 | | |
| 18 | Y26106-080162 | ÄÉÞÍÞÜÄ 8X 16 | BOLT M 8X 16 PLATED | 3 | | |
| 19 | Y26106-080602 | ÄÉÞÍÞÜÄ 8X 60 | BOLT M 8X 60 PLATED | 3 | | |
| 20 | Y129556-42350 | VÍß-Ø(96) | V-PULLEY (96) | 1 | | |
| 20-1 | Y129403-42380 | VÍß-Ø(110) | V-PULLEY (110) | 1 | S | |
| (Machine Serial No. 14515346-) | | | | | | |
| 20-2 | Y129556-42350 | VÍß-Ø(96) | V-PULLEY (96) | 1 | S | |
| (Machine Serial No. 14517074-) | | | | | | |
| 21 | Y25152-003700 | VÍÞÜÄ(Û°Ä¼ÞA37 | V-BELT | 1 | | |
| 22 | Y129655-44740 | ,-ØÝ, ÞÍ±Ý(D380 | FAN, COOLING | 1 | | |
| 23 | Y121550-49111 | ¼ÞÖ²ÝÄ PT1/4 | JOINT PT1/4 | 1 | | |
| 24 | Y26106-080122 | ÄÉÞÍÞÜÄ 8X 12 | BOLT M 8X 12 PLATED | 1 | | |
| 25 | Y129457-49801 | »-Ó½ÄÄÄ(82 | THERMOSTAT(82 | 1 | | |
| 26 | Y129150-49811 | PK(»-Ó½ÄÄÄ ¼Ä)(ÉÝ±½) | GASKET, (NON-ASB.) | 1 | | |
| 27 | Y129350-49530 | »-Ó½ÄÄÄ¶ÉÞ-(ÍÞ×Ä, :12 | COVER, THERMOSTAT | 1 | | |
| 28 | Y129795-49551 | PK(»-Ó½ÄÄÄ¶ÉÞ-)(ÉÝ±½ | GASKET, (NON-ASB.) | 1 | | |
| 29 | Y26106-080222 | ÄÉÞÍÞÜÄ 8X 22 | BOLT M 8X 22 PLATED | 2 | | |
| 30 | Y23414-080000 | ÉßÄ·Ý(ÍÜ 8 | GASKET 8, ROUND | 1 | | |
| 31 | Y121250-44901 | »-Ó½²ÄÄ(110ßC 1¾Ý¼· | SWITCH, THERMO(110ßC | 1 | | |
| 32 | Y124465-44950 | ÉßÄ·Ý16 | GASKET 16 | 1 | | |
| 33 | Y129004-49610 | CW-T A CMP(MP2 | PIPE ASSY, A MP2 | 1 | | |
| 34 | Y129004-49711 | • CW-T A(MP2 | • PIPE ASSY, A MP2 | 1 | | |
| 35 | Y119802-49730 | • ÍÜÄÞÖ(CW-T | • CLAMP, CW-T | 1 | | |
| 36 | Y124722-59050 | • Í-½,ØÄÍß(ÍÜ 9 | • CLAMP 9 | 2 | | |
| 37 | Y129004-49620 | CW-T B CMP(MP2 | PIPE ASSY, B MP2 | 1 | | |
| 38 | Y129004-49721 | • CW-T B(MP2 | • PIPE, WATER B MP2 | 1 | | |
| 39 | Y124722-59050 | • Í-½,ØÄÍß(ÍÜ 9 | • CLAMP 9 | 2 | | |
| 40 | Y121267-44760 | ½Íß-» (ÍÞ×Ä, :12) | SPACER | 1 | | |
| 41 | Y26106-060302 | ÄÉÞÍÞÜÄ 6X 30 | BOLT M 6X 30 PLATED | 4 | | |
| 42 | Y26106-080452 | ÄÉÞÍÞÜÄ 8X 45 | BOLT M 8X 45 PLATED | 1 | | |
| 43 | Y119266-49350 | »-Ó¾Ý»- | SENSOR, THERMO. | 1 | | |
| 44 | Y129150-49360 | PK 10 | GASKET 10 | 1 | | |
| 45 | Y171064-44510 | »ÍÞÄÝ, CMP | SUB-TANK ASSY | 1 | | |
| 47 | Y121450-44531 | • ÖÄÍß | • CAP | 1 | | |
| 48 | Y124450-44560 | • µ»'(µ-ÉÞ-ÍÜ-Éß³Íß | • CLAMP | 1 | | |
| 49 | Y121470-44581 | • ÉßÄ·Ý | • GASKET | 1 | | |
| 50 | Y23065-070225 | • 23061-070300(Ä³Ö²í | • PIPE 7X 225 | 1 | | |
| 51 | Y124450-44550 | ÉÞÝÄÞ(»ÍÞÄÝ, | CLAMP, SUB-TANK | 1 | | |
| 52 | Y121256-44600 | ÍÞ×¹ÄÄ (ÍÞ×Ä, :12) | BRACKET, SUB-TANK | 1 | | |
| 53 | Y129612-49030 | CW-T (A | PIPE, COOLING WATER | 1 | | |
| 54 | Y129612-49040 | CW-T (B | PIPE, COOLING WATER | 1 | | |
| 55 | Y23010-038000 | Í-½ÉÞÝÄÞ 38 | CLAMP 38 | 2 | | |
| 56 | Y23010-044000 | Í-½ÉÞÝÄÞ 44 | CLAMP 44 | 2 | | |
| 57 | Y119255-44660 | ÍÞ³¼ÝºÞÑ(×¼Þ·Ä | RUBBER | 2 | | |
| 58 | Y129150-49100 | »ÝÍß³ºÄ, CMP | COCK ASSY, 3-WAY | 1 | | |
| 59 | Y129150-49080 | • ÄÞÜÝºÄ, | • COCK, DRAIN | 1 | | |
| 63 | Y129642-44500 | ×¼Þ·-Ä ASSY | RADIATOR ASSY | 1 | | |
| 64 | Y129107-44590 | • ÖÄÍß(0.9KG/CM2) D46 | • CAP, RADIATOR | 1 | | |
| 65 | Y129467-44580 | • í³ÝÄ×ÉÞ- | • MOUNT RUBBER | 2 | | |
| 66 | Y129467-44590 | • ¶×- | • COLLAR | 2 | | |

CLICK HERE TO **DOWNLOAD** THE COMPLETE MANUAL

- Thank you very much for reading the preview of the manual.
- You can download the complete manual from: www.heydownloads.com by clicking the link below



- Please note: If there is no response to CLICKING the link, please download this PDF first and then click on it.

CLICK HERE TO **DOWNLOAD** THE COMPLETE MANUAL