



TADANO

HYDRAULIC CRANE PARTS CATALOG

MODEL TL-250M-1

**INFORMATION No. TL-250M-1/P-03
SERIAL No. 340001**

**Used Crane Specialist
Sales, Service & Parts
Manufacture Support**

CLICK HERE TO **DOWNLOAD** THE COMPLETE MANUAL

- Thank you very much for reading the preview of the manual.
- You can download the complete manual from: www.heydownloads.com by clicking the link below



- Please note: If there is no response to CLICKING the link, please download this PDF first and then click on it.

CLICK HERE TO **DOWNLOAD** THE COMPLETE MANUAL

6. PARTS SUPPLIED IN SETS. AND PARTS NOT AVAILABLE FOR SALE

6-1. PARTS SUPPLIED IN SETS

In the illustrations, those parts which are supplied only in sets are indicated as shown below.

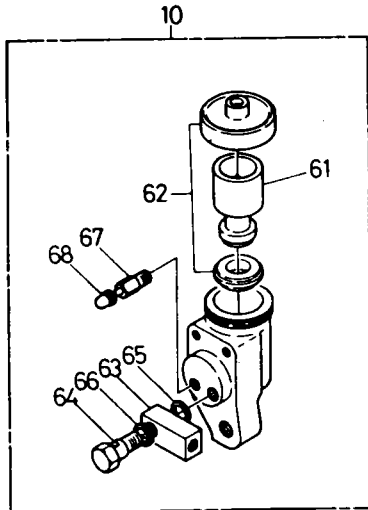

6-2. PARTS NOT AVAILABLE FOR SALE

Those parts which have no key No. are ones not available for sale as a single part. They are available for supply in sets with their related parts.

7. HOW TO ORDER PARTS

7-1. WHEN ORDERING PARTS. MAKE SURE TO NOTIFY US OF THE FOLLOWING ITEMS

Model, Serial No., parts No., parts name, required quantity, carrier model, and shipping method.

Note) 1. When "N" or "M" is printed in the quantity space of the part list, indicate the required quantity or the required length to us. With some parts, however, minimum purchase quantities are set.

Example: Some O-rings are available only in a set of 10 pieces. In such cases, 10 pieces of O-rings are delivered even when the customer's order was for one piece.

7-2. ALTERED PART

When an old part is replaceable when the corresponding new part, order the new part.

6. セット販売部品、非販売部品

6-1. セット販売部品

イラスト中、次のように表示されているものは、その部品がセット販売されることを示します。

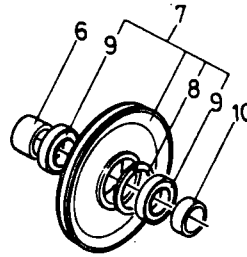

6-2. 非販売部品

部品に指示番号がない場合には、その部品は単独では供給できず、セット部品として供給が可能になることを示します。

7-1. 部品注文の際は、次の事項を連絡してください。

機種、製造番号、部品番号、部品名、必要個数、架装車種、発送方法

注意) 1. リストの中で個数がN, Mと表示されているときは、必要個数、必要長さを指示していただきますが、当社の販売単位による場合があります。

例: Oリングでは、1個の注文でも10個になる場合があります。

7-2. 変更部品

新部品から旧部品への互換性のある場合は、新部品を注文してください。(互換性は、リスト中の変更番号に基づき部品変更リストにて確認してください。)

システム インデックス SYSTEM INDEX

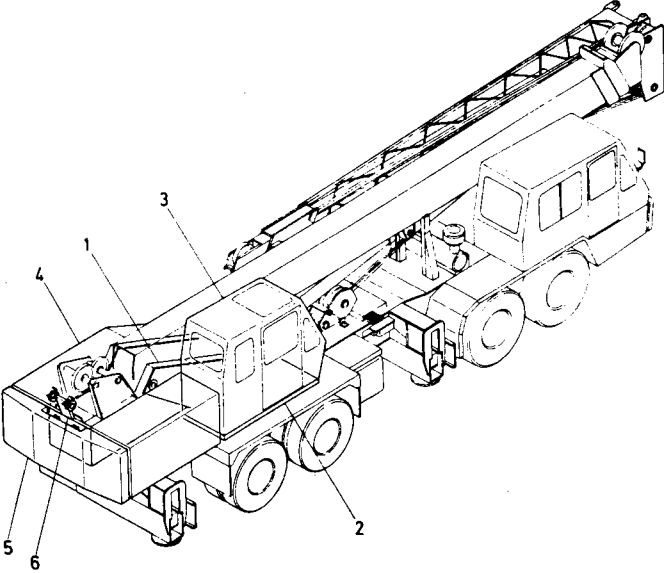
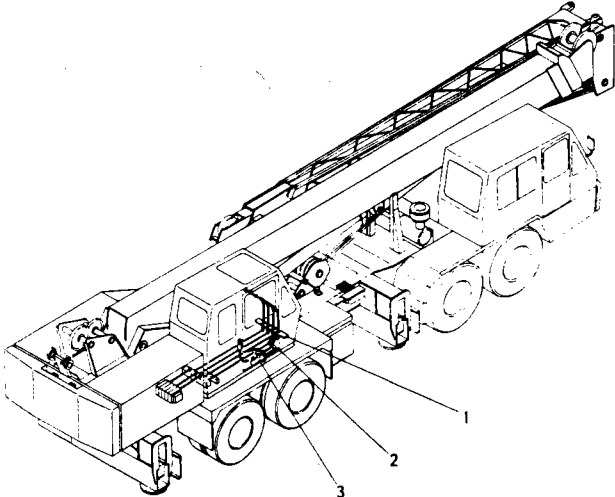
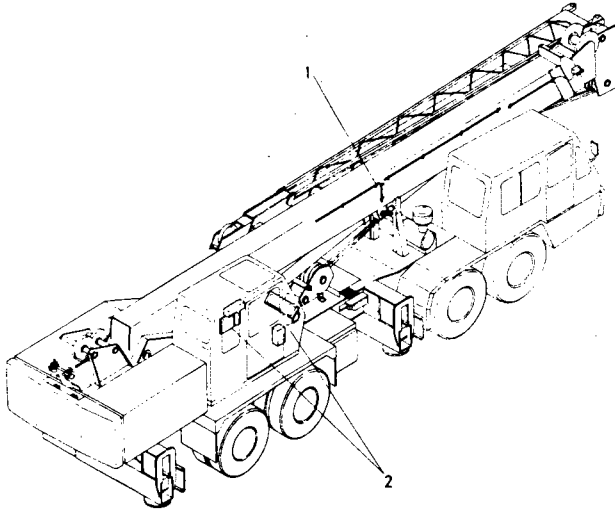
指示番号 Key No.	9	ページ Page	34	指示番号 Key No.	11	ページ Page	38
				<ul style="list-style-type: none"> ① スイング フレーム SWING FRAME ② スイング テーブル SWING TABLE ③ キャブ, オペレータ CAB, OPERATOR'S ④ カバー, スイング フレーム COVER, SWING FRAME ⑤ ウェイト, カウンタバランス WEIGHT, COUNTERBALANCE ⑥ リムービング デバイス, カウンタバランス ウェイト REMOVING DEVICE, COUNTERBALANCE WEIGHT 			
<ul style="list-style-type: none"> ① オペレーション システム, コントロール バルブ OPERATION SYSTEM, CONTROL VALVE ② オペレーション システム, アクセル OPERATION SYSTEM, ACCELERATOR ③ シリンダ, マスタ CYLINDER, MASTER 				<ul style="list-style-type: none"> ① エレクトリカル, アクセサリ ELECTRICAL, ACCESSORIES ② エレクトリカル パーツ, キャブ ELECTRICAL PARTS, CAB ③ ワイヤリング, マテリアルズ WIRING, MATERIALS 			

システム 名称
System Name

カク フン
MOUNTING PARTS

FIG. PX100-0120-00

スペック 番号
Specification No.

A < TL-250M-1-10101
D < TL-250M-1-20102

> B < TL-250M-1-10102

> C < TL-250M-1-20101

>

指示番号 Key No.	組立名称 Assembly Name	Q'ty Per Section 個数														実施号機 (変更番号)	Serial No. Modifi. No.)	ページ Page	
		A	B	C	D	E	F	G	H	I	J	K	L	M	N				O
1	タンクサポート、インストール TANK SUPPORT, INSTALLATION	1	1	1	1												-	340192	466 467
1	タンク サポート インストール TANK SUPPORT INSTALLATION	1	1	1	1												340193	-	468 469
2	ブーム レストインストール BOOM RESTINSTALLATION	1	1	1	1														470 471
3	アウトリガー サポート インストール OUTRIGGER SUPPORT INSTLLATION	-	-	1	1														472 473
3	アウトリガー サポート インストール OUTRIGGER SUPPORT INSTLLATION	1	1	-	-														472 473
4	アタッチメント パーツ、スイング アリク ATTACHMENT PARTS, SWING BEARING	-	-	1	1														474 475
4	アタッチメント パーツ、スイング アリク ATTACHMENT PARTS, SWING BEARING	1	1	-	-														474 475
5	マウント、フック(メイン) MOUNT, HOOK(MAIN)	-	-	1	1														480 481
5	マウント、フック(メイン) MOUNT, HOOK(MAIN)	1	1	-	-														480 481
6	マウント、フック (オクシアリ) MOUNT, HOOK (AUXILIARY)	-	-	1	1														476 477
6	マウント、フック (オクシアリ) MOUNT, HOOK (AUXILIARY)	1	1	-	-														478 479
7	サイド ガード インストール SIDE GUARD INSTALLATION	1	1	-	-														482 483
8	ポンプ インストール PUMP, INSTALLATION	-	-	1	1														484 485
8	ポンプ インストール PUMP INSTALLATION	1	1	-	-														486 487
9	ステップ インストール STEP INSTALLATION	1	1	1	1														488 489

ページ欄 上段はイラストページ、下段はリストページを示す。

In the "page" column, the upper numbers denote illustration pages, and the lower list pages.

3 (WINCH)

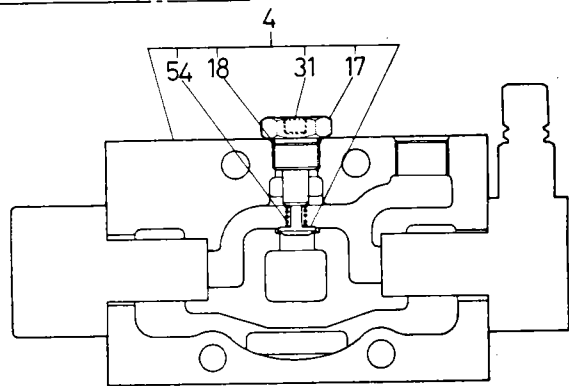
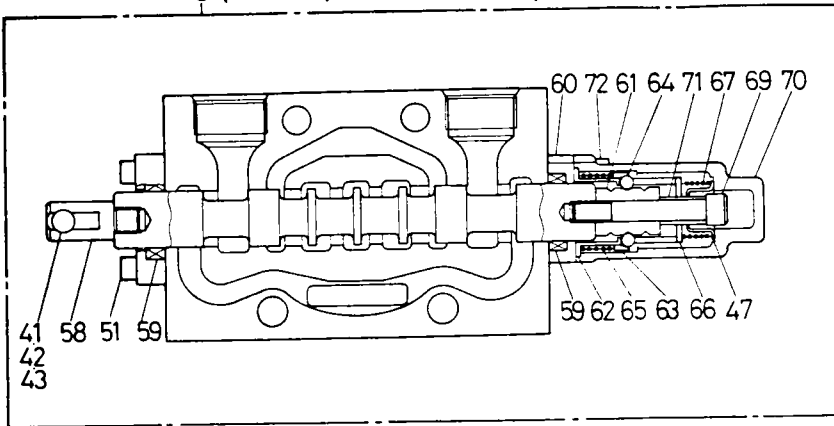

1 (ELEVATING)

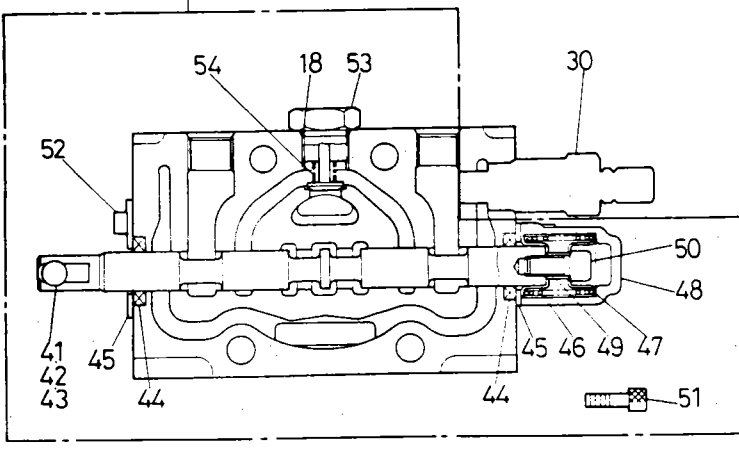

2 (TELESCOPING)

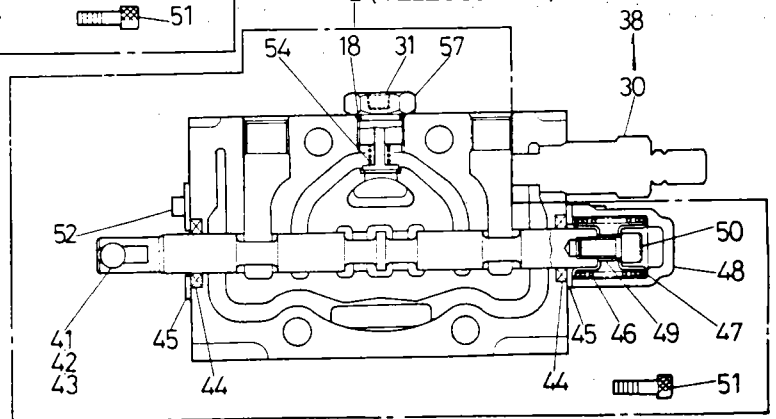

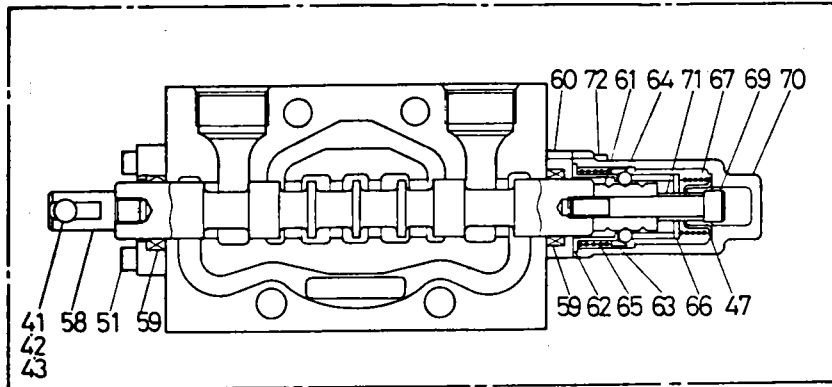

3 (WINCH)

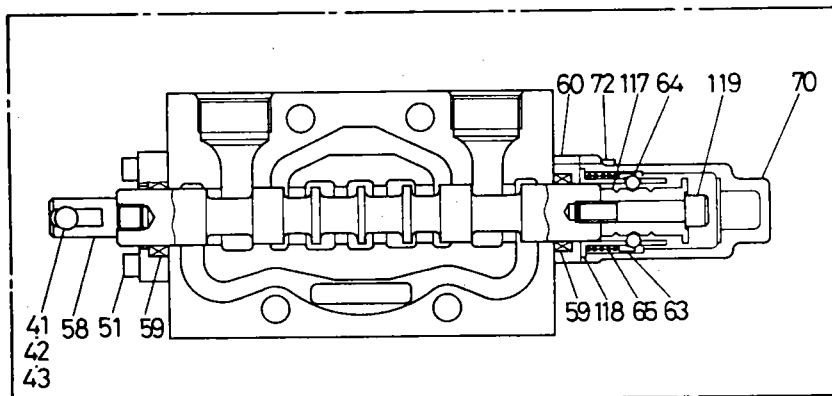

4 (WINCH)

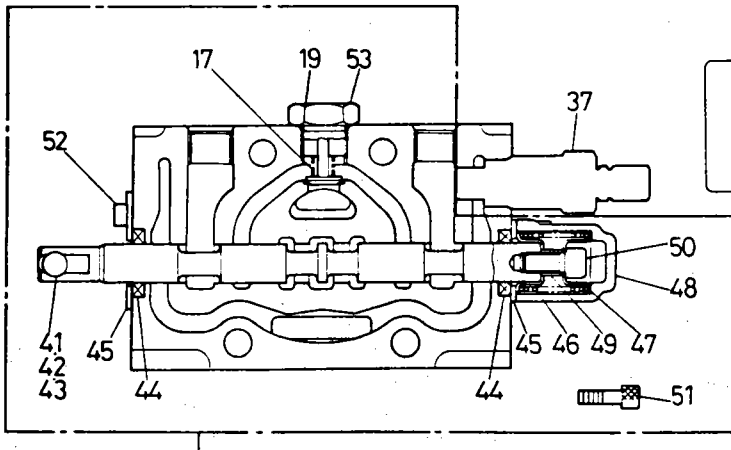

1 (ELEVATING)

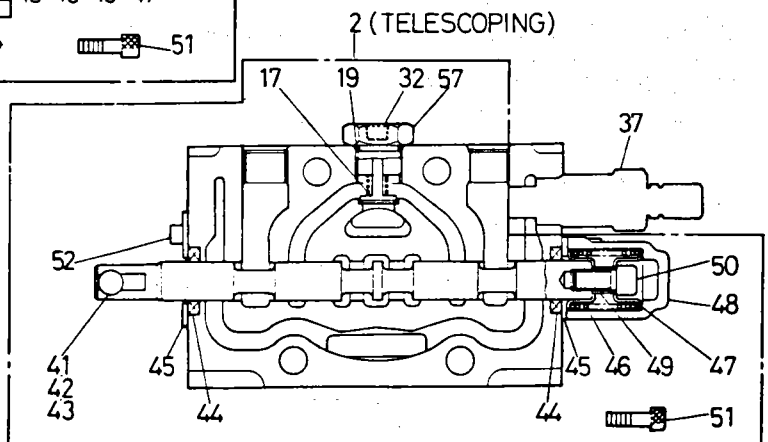
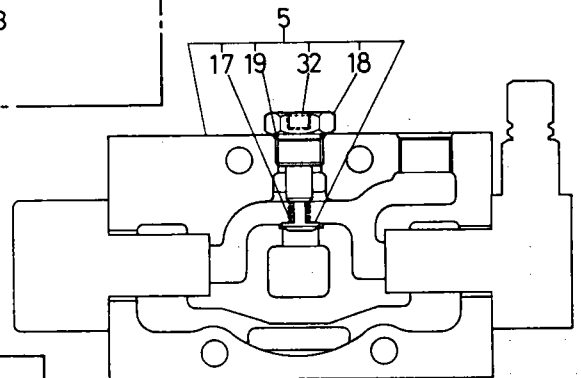

2 (TELESCOPING)

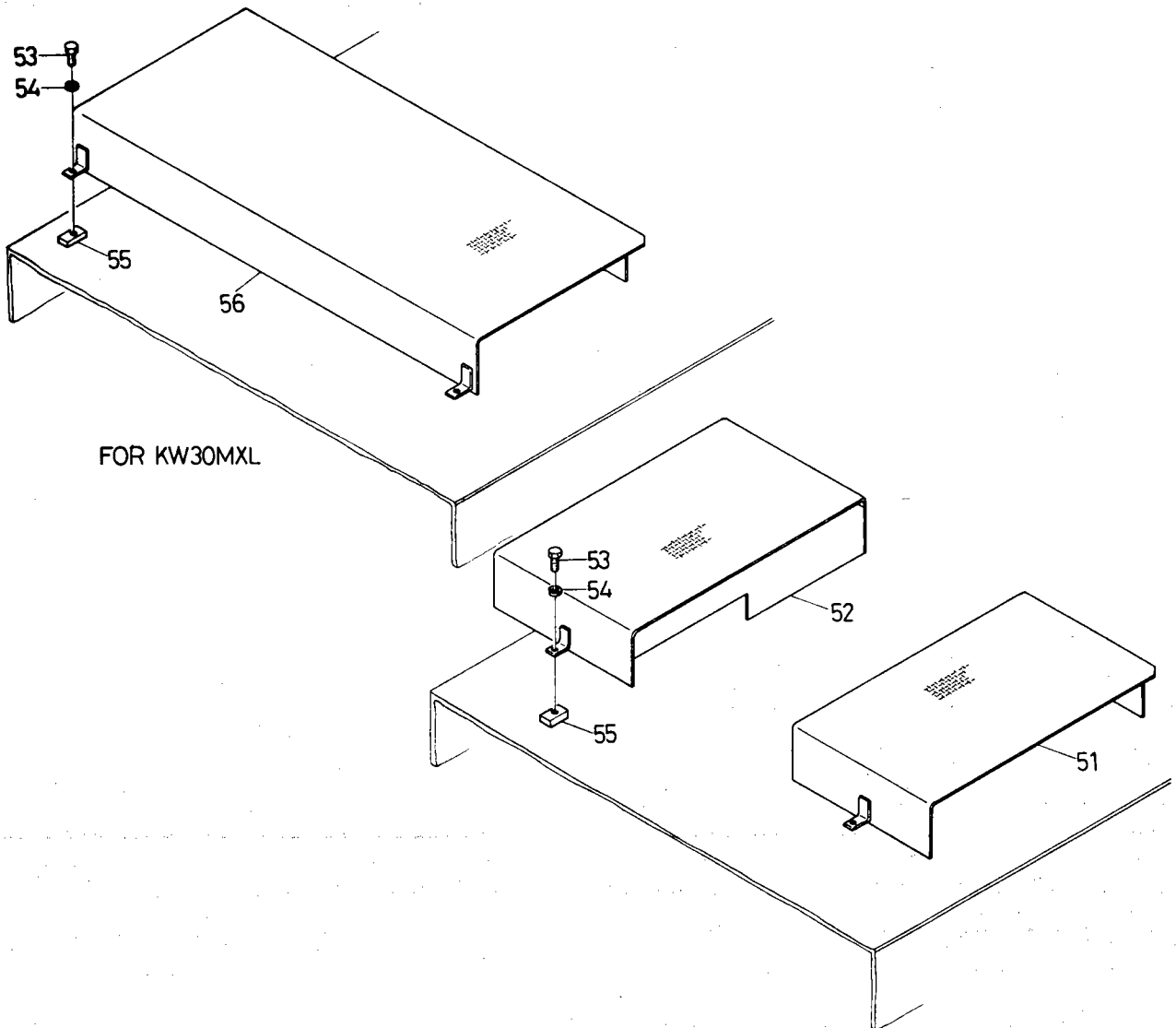

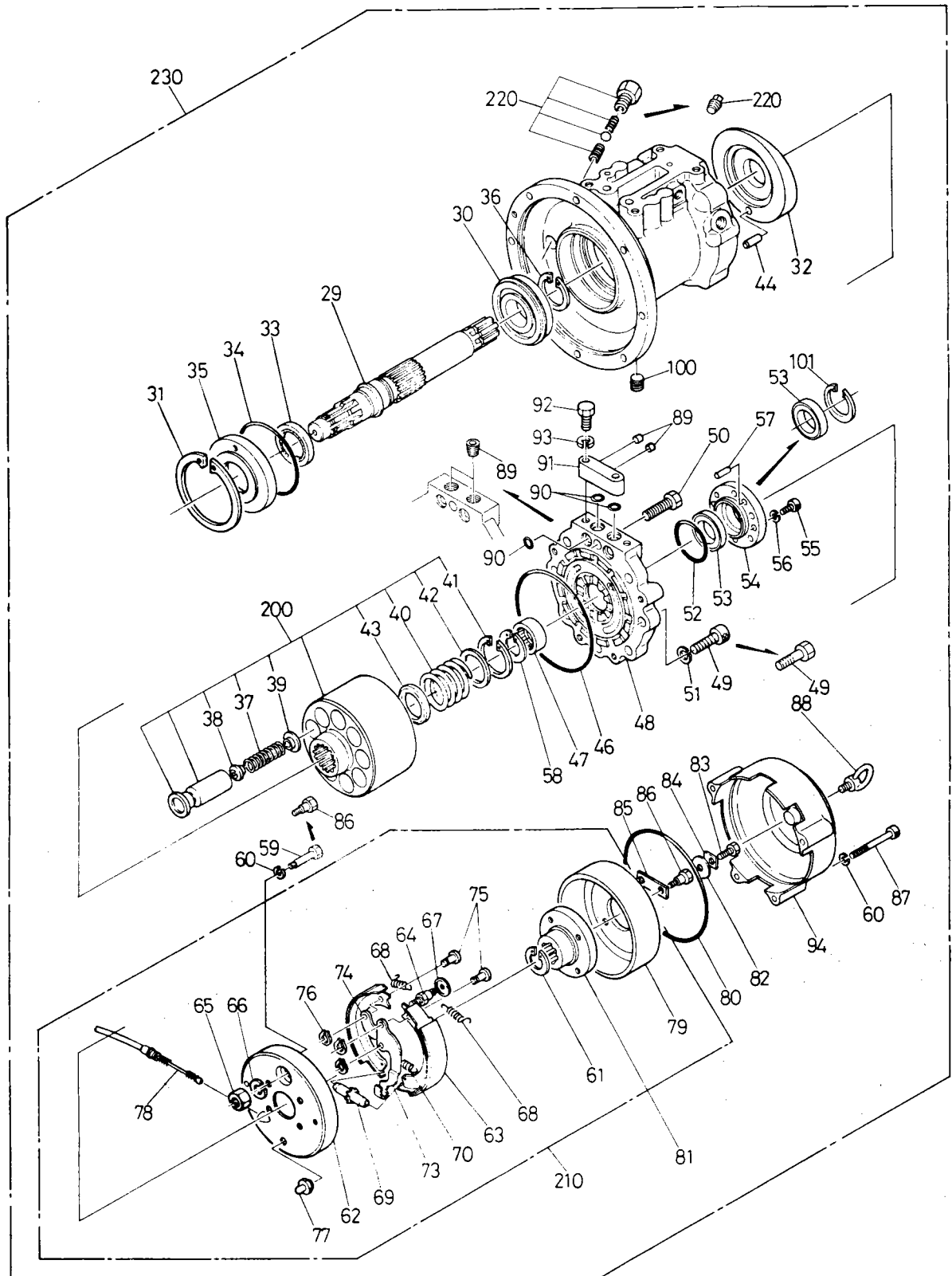

スペック番号: A < TL-250M-1-10101 > B < TL-250M-1-10102 > C < TL-250M-1-20101 >
 Specification No. D < TL-250M-1-20102 >

指示番号 Key No.	部品番号 Part No.	部品名称 Part Name	Q'ty Per Section 個数													実施号 (変更番号)	Serial No. Modifi. No.	ページ Page	
			A	B	C	D	E	F	G	H	I	J	K	L	M				N
1	333-301-30200	SWITCH ASSY	1	1	1	1											(- 340225 - 2010363)	
1	333-301-30201	SWITCH ASSY	1	1	1	1											(340226 - (2010363 -)	
2	901-012-06012	BOLT M6X12	2	2	2	2													
3	903-020-40601	WASHER, SPRING 6	2	2	2	2													
4	903-030-70601	WASHER, PLAIN 6	2	2	2	2													
11	333-301-30100	PLATE	1	1	1	1											(- 340225 - 2010363)	
11	333-301-30100	PLATE	1	1	1	1											(340226 - (2010363 -)	
12	821-000-00895	SWITCH, TOGGLE	1	1	1	1											(- 340225 - 2010363)	
12	821-000-01682	SWITCH, TOGGLE S-1BW	1	1	1	1											(340226 - (2010363 -)	
13	821-000-00182	SLEEVE	3	3	3	3											(- 340225 - 2010363)	
13	821-000-00182	SLEEVE	4	4	4	4											(340226 - (2010363 -)	
14	821-000-00191	TERMINAL	1	1	1	1											(- 340225 - 2010363)	
15	821-000-00183	SLEEVE	1	1	1	1											(- 340225 - 2010363)	
16	821-000-00192	TERMINAL	1	1	1	1											(- 340225 - 2010363)	
16	821-000-00192	TERMINAL	2	2	2	2											(340226 - (2010363 -)	

組立名称
Assembly Name

フック (オクシ17リ)
HOOK (AUXILIARY)

FIG. PF105-0180-01

仕様番号
Specification No.

A < TL-250M-1-10101 > B < TL-250M-1-10102 > C < TL-250M-1-20101 >
D < TL-250M-1-20102 >

指示番号 Key No.	部品番号 Part No.	部品名称 Part Name	Q'ty Per Section 個数																実施号 (変更番号)	Serial No. Modifi. No.)	ページ Page
			A	B	C	D	E	F	G	H	I	J	K	L	M	N	O				
4	805-000-51309	BEARING,BALL 51309	1	1	1	1															
6	162-616-06000	STOPPER	1	1	1	1												- 340314			
6	349-200-30050	PLATE	1	1	1	1											(340315 -	(
8	901-012-10020	BOLT M10X20	1	1	1	1											(2023670 -)		
9	903-020-41001	WASHER,SPRING 10	1	1	1	1															
10	370-001-01930	PIN	1	1	1	1															
12	165-116-05000	PIN	1	1	1	1															
13	903-030-70801	WASHER,PLAIN 8	2	2	2	2															
14	801-360-20015	PIN,SPLIT 2X15	2	2	2	2															
15	165-116-06000	SPRING	1	1	1	1															
16	360-900-99520	HOOK ASSY	1	1	1	1															
17	824-561-01000	NIPPLE,GREASE	1	1	1	1															
20	360-902-49510	A-PT1/8 BODY,ASSY HOOK	1	1	1	1															
30	166-116-95510	SHAFT ASSY	1	1	1	1															
40	360-900-99510	STOPPER ASSY	1	1	1	1															
50	360-902-40001	HOOK (AUXILIARY)	1	1	1	1															

組立名称 Assembly Name	オペレーションシステム、クインチ ブレーキ OPERATION SYSTEM, WINCH BRAKE			FIG. PF111-0034-02
スペック番号 Specification No.	A < TL-250M-1-10101 D < TL-250M-1-20102	> B < TL-250M-1-10102	> C < TL-250M-1-20101	>

指示番号 Key No.	部品番号 Part No.	部品名称 Part Name	Q'ty Per Section 個数													実施号 (変更番号)	Serial No. Modifi. No.)	ページ Page	
			A	B	C	D	E	F	G	H	I	J	K	L	M				N
1	901-012-06012	BOLT M6X12	4	4	4	4													
2	903-020-40601	WASHER, SPRING 6	4	4	4	4													
3	370-017-00070	CABLE, CONTROL	1	1	1	1													
4	370-017-00090	CABLE, CONTROL	1	1	1	1													
7	918-013-00150	BAND 15	6	6	6	6													- 340192 (- 2008774)
7	918-013-00150	BAND 15	6	6	6	6													
9	901-022-12020	BOLT M12X20	8	8	8	8													
10	903-020-41201	WASHER, SPRING 12	8	8	8	8													
14	591-590-15000	NUT, FLARE	6	6	6	6													
15	814-010-80001	PIPE, STEEL 8X0.7	2	2	2	2													
16	814-010-80001	PIPE, STEEL 8X0.7	2	2	2	2													
17	370-007-00530	CLAMP ASSY	1	1	1	1													
18	333-301-10060	FITTING	2	2	2	2													
19	333-300-10070	SUPPORT	4	-	4	-													- 340004 (- 2001735)
20	901-022-08012	BOLT M8X12	4	-	4	-													- 340004 (- 2001735)
20	901-022-08012	BOLT M8X12	-	2	-	2													
20	901-022-08012	BOLT M8X12	2	-	2	-													340005 - (2001735 -)
21	903-020-40801	WASHER, SPRING 8	8	-	8	-													- 340004 (- 2001735)
21	903-020-40801	WASHER, SPRING 8	-	6	-	6													
21	903-020-40801	WASHER, SPRING 8	6	-	6	-													340005 - (2001735 -)
22	333-300-18020	LEVER ASSY	1	-	1	-													- 340004 (- 2001735)
22	333-300-18021	LEVER ASSY	-	1	-	1													
22	333-300-18021	LEVER ASSY	1	-	1	-													340005 - (2001735 -)
23	333-301-18010	LINK ASSY	1	1	1	1													
24	370-008-00000	JOINT	1	1	1	1													
25	901-022-10016	BOLT M10X16	2	2	2	2													
26	903-020-41001	WASHER, SPRING 10	2	2	2	2													
27	824-000-00118	CLAMP	1	1	1	1													
28	333-301-18020	LINK ASSY	1	1	1	1													
29	801-473-10440	LIVET	6	6	6	6													
30	333-301-13000	COVER	2	2	2	2													
31	333-300-14000	LINK ASSY	2	2	2	2													
32	333-300-10120	END	2	3	2	3													
32	333-300-10120	END	1	-	1	-													- 340004 (- 2001735)
32	333-300-10120	END	1	-	1	-													340005 - (2001735 -)
33	903-030-70601	WASHER, PLAIN 6	6	6	6	6													
34	801-360-20012	PIN, SPLIT 2X12	6	9	6	9													
34	801-360-20012	PIN, SPLIT 2X12	3	-	3	-													- 340004 (- 2001735)
34	801-360-20012	PIN, SPLIT 2X12	3	-	3	-													340005 - (2001735 -)
35	563-403-09000	PIN	2	3	2	3													

組立名称
Assembly Name

パイプ・クレーン
PIPING, WINCH

FIG. PF120-0034-00

仕様番号
Specification No.

A < TL-250M-1-10101 > B < TL-250M-1-10102 > C < TL-250M-1-20101 >
D < TL-250M-1-20102 >

指示番号 Key No.	部品番号 Part No.	部品名称 Part Name	Q'ty Per Section 個数																実施号 (変更番号)	Serial No. Modifi. No.)	ページ Page
			A	B	C	D	E	F	G	H	I	J	K	L	M	N	O				
89	901-012-06055	BOLT M6X55	-	2	-	2													366		
90	903-020-40601	WASHER, SPRING 6	-	2	-	2															
91	192-251-42000	VALVE, SHUTTLE	-	1	-	1															
92	901-012-08050	BOLT M8X50	-	2	-	2															
93	814-080-00081	PIPE, STEEL 8	-	1	-	1															
			M			M															
94	814-080-00081	PIPE, STEEL 8	-	1	-	1															
			M			M															
96	901-012-12030	BOLT M12X30	-	1	-	1															
97	901-012-12050	BOLT M12X50	-	3	-	3															
98	902-012-01200	NUT M12	-	3	-	3															
99	903-020-41201	WASHER, SPRING 12	-	4	-	4															
102	370-009-06920	JOINT	-	1	-	1															
103	333-408-00050	COVER	-	1	-	1															
104	909-370-50121	SCREW, TAPPING M5X12	-	6	-	6															
105	903-052-00501	WASHER 5	-	6	-	6															
106	803-160-30040	PLUG PT1/4	-	3	-	3															
110	910-013-02400	O, RING WP24	-	4	-	4															

組立名称
 Assembly Name
 ハイボック、ウインチ フレキ
 PIPING, WINCH BRAKE

FIG. PF122-0022-00

スペック番号
 Specification No.
 A < TL-250M-1-10101 > B < TL-250M-1-10102 > C < TL-250M-1-20101 >
 D < TL-250M-1-20102 >

指示番号 Key No.	部品番号 Part No.	部品名称 Part Name	Q'ty Per Section 個数													実施号 (変更番号)	Serial No. Modifi. No.)	ページ Page			
			A	B	C	D	E	F	G	H	I	J	K	L	M				N	O	
2	814-010-80001	PIPE,STEEL 8X0.7	1	1	1	1															
			M	M	M	M															
3	814-010-80001	PIPE,STEEL 8X0.7	1	1	1	1															
			M	M	M	M															
4	370-007-01380	CLAMP ASSY	1	1	1	1															
5	591-590-40000	FITTING	2	2	2	2															
6	370-007-00620	CLAMP ASSY	1	1	1	1															
7	902-112-51401	NUT M14	2	2	2	2															
8	903-041-11401	WASHER,TOOTH 14	2	2	2	2															
9	194-152-00270	HOSE	2	2	2	2															
10	814-010-80001	PIPE,STEEL 8X0.7	2	2	2	2															
			M	M	M	M															
11	333-404-10100	SUPPORT	1	1	1	1															
12	591-590-15000	NUT,FLARE	8	8	8	8															
13	814-010-80001	PIPE,STEEL 8X0.7	1	1	1	1															
			M	M	M	M															

組立名称
Assembly Name

ジョイント・ウィンチ ロータリ-
JOINT, WINCH ROTARY

FIG. PF132-0020-00

スペック番号 A < TL-250M-1-10101 > B < TL-250M-1-10102 > C < TL-250M-1-20101 >
Specification No. D < TL-250M-1-20102 >

指示番号 Key No.	部品番号 Part No.	部品名称 Part Name	Q'ty Per Section 個数													実施号 (変更番号)	Serial No. Modifi. No.)	ページ Page	
			A	B	C	D	E	F	G	H	I	J	K	L	M				N
1	141-255-01000	SPRING	1	1	1	1													
2	141-255-02000	WASHER	1	1	1	1													
3	141-255-04000	ADAPTER	1	1	1	1													
4	141-255-05000	PACKING	5	5	5	5													
5	141-255-07000	ADAPTER	1	1	1	1													
7	366-704-70010	SPACER	1	1	1	1													
8	806-011-10170	RING, RETAINING S17	1	1	1	1													
9	161-155-52000	WASHER	1	1	1	1													
11	805-160-06303	BEARING, BALL 6303ZZ	1	1	1	1													
12	806-021-10470	RING, RETAINING R47	1	1	1	1													
13	161-155-54000	SLEEVE	1	1	1	1													
20	366-704-70000	JOINT, WINCH ROTARY	1	1	1	1													

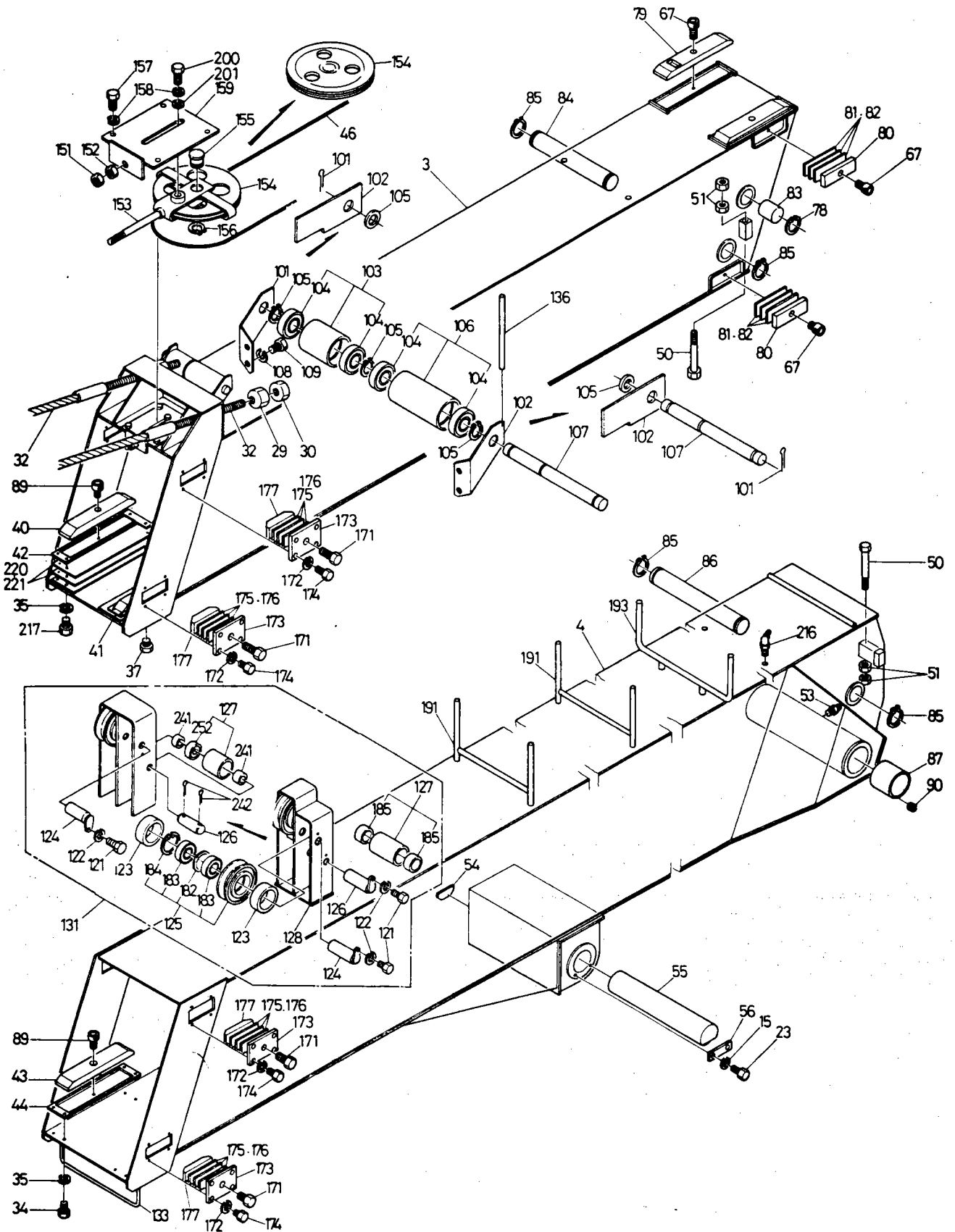

CLICK HERE TO **DOWNLOAD** THE COMPLETE MANUAL

- Thank you very much for reading the preview of the manual.
- You can download the complete manual from: www.heydownloads.com by clicking the link below



- Please note: If there is no response to CLICKING the link, please download this PDF first and then click on it.

CLICK HERE TO **DOWNLOAD** THE COMPLETE MANUAL

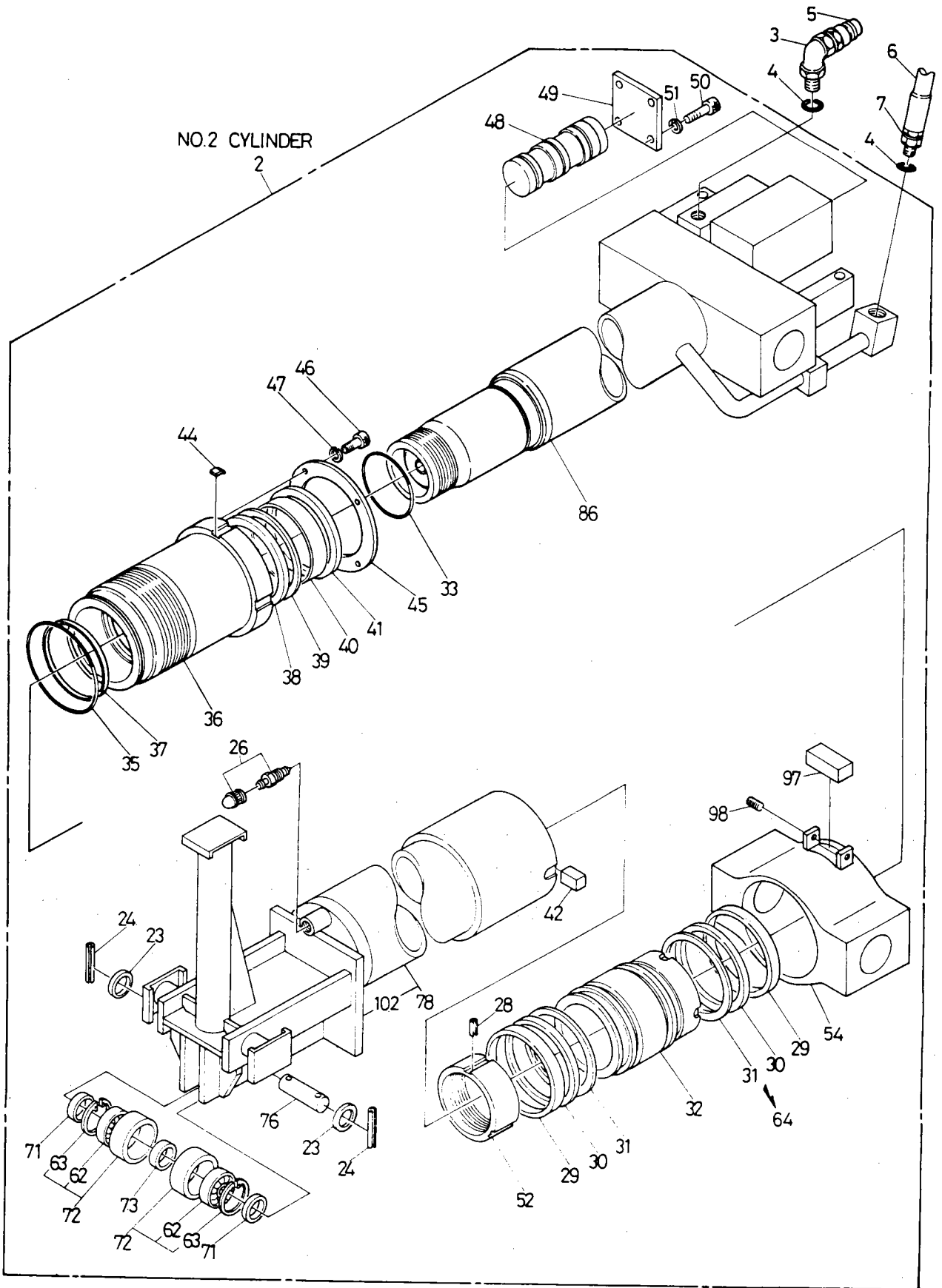

組立名称
Assembly Name

ディテクタ システム, フーム レンクス
DETECTOR SYSTEM, BOOM LENGTH

FIG. PG112-0001-02

スペック 番号 A < TL-250M-1-10101 > B < TL-250M-1-10102 > C < TL-250M-1-20101 >
Specification No. D < TL-250M-1-20102 >

指示番号 Key No.	部品番号 Part No.	部品名称 Part Name	Q'ty Per Section 個数														実施号 (変更番号)	Serial No. Modifi. No.)	ページ Page	
			A	B	C	D	E	F	G	H	I	J	K	L	M	N				O
1	361-300-70005	DETECTOR, BOOM LENGTH	1	1	1	1												(- 340192 - 7000026)	290
1	361-300-70006	DETECTOR, BOOM LENGTH	1	1	1	1												(340193 (7000026 -)	292
2	333-700-20670	SUPPORT	4	4	4	4														
3	901-315-08018	BOLT, HEXAGON SOCKET M8X18	4	4	4	4														
4	903-020-40801	WASHER, SPRING 8	4	4	4	4														
5	903-031-00801	WASHER, PLAIN 8	4	4	4	4														
6	333-700-20620	SUPPORT	2	2	2	2												(- 340180 - 2005732)	
6	333-700-20620	SUPPORT	1	1	1	1												(340181 (2005732 -)	
7	333-700-20610	SUPPORT	3	3	3	3														
8	333-700-20660	SUPPORT	1	1	1	1														
9	821-000-02004	CLAMP	2	2	2	2												(- 340180 - 2005732)	
9	821-000-02004	CLAMP	1	1	1	1												(340181 (2005732 -)	
10	901-900-00008	BOLT, STUD M6X20	2	2	2	2												(- 340180 - 2005732)	
10	901-900-00008	BOLT, STUD M6X20	1	1	1	1												(340181 (2005732 -)	
11	902-012-00600	NUT M6	2	2	2	2												(- 340180 - 2005732)	
11	902-012-00600	NUT M6	1	1	1	1												(340181 (2005732 -)	
12	903-020-40601	WASHER, SPRING 6	2	2	2	2												(- 340180 - 2005732)	
12	903-020-40601	WASHER, SPRING 6	1	1	1	1												(340181 (2005732 -)	
13	333-703-51000	GUARD	1	1	1	1														

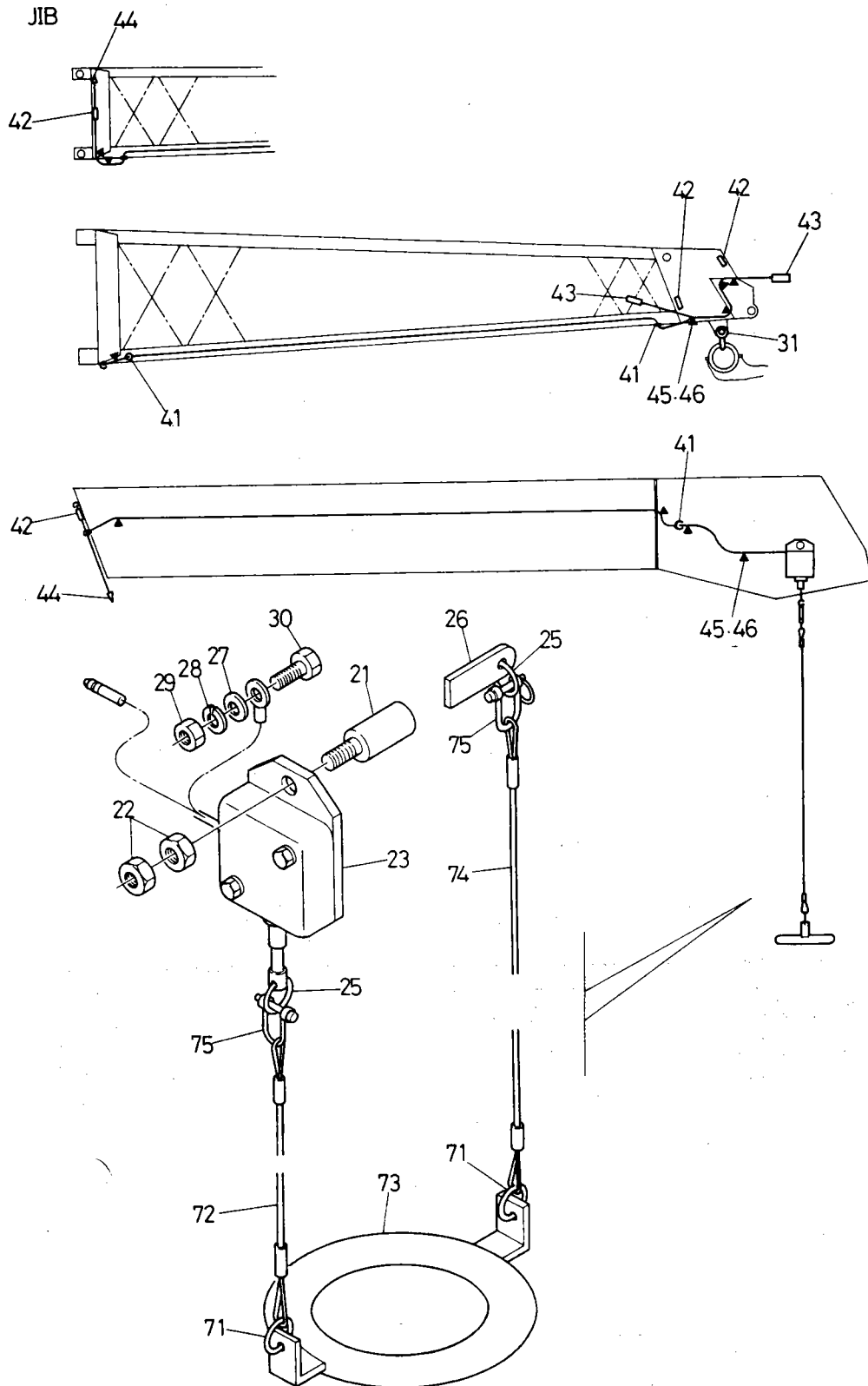

組立名称: スイッチ、オーバ" ワインディング" タイマクタ
 Assembly Name: SWITCH, OVER WINDING DETECTOR (JIB&S/T) FIG: PH107-0040-00

スペック番号: A < TL-250M-1-10101. > B < TL-250M-1-10102 > C < TL-250M-1-20101 >
 Specification No. D < TL-250M-1-20102 >

指示番号 Key No.	部品番号 Part No.	部品名称 Part Name	Qty Per Section 個数														実施号 (変更番号)	Serial No. Modifi. No.)	ページ Page	
			A	B	C	D	E	F	G	H	I	J	K	L	M	N				O
1	323-700-02170	COVER	1	1	1	1														
2	323-700-02110	GASKET	1	1	1	1														
3	323-700-02120	COVER	1	1	1	1														
4	801-623-03025	SCREW, MACHINE M3X25	2	2	2	2														
5	903-020-40301	WASHER, SPRING 3	2	2	2	2														
6	821-000-01355	SWITCH, LIMIT	1	1	1	1														
7	323-700-02130	ROD	1	1	1	1														
8	141-483-73001	SPRING	1	1	1	1														
9	806-011-10180	RING, RETAINING S18	1	1	1	1														
10	323-700-02160	SUPPORT	1	1	1	1														
11	903-030-70301	WASHER, PLAIN 3	2	2	2	2														
12	821-000-01194	CONNECTOR	1	1	1	1														
13	821-000-00182	SLEEVE	2	2	2	2														
14	323-700-05200	CORD	1	1	1	1														
15	323-700-05210	CORD	1	1	1	1														
16	821-000-00592	TERMINAL	2	2	2	2														
17	323-700-05220	TUBE, VINYL 6X8	1	1	1	1														
18	141-483-75000	GROMMET	1	1	1	1														
19	901-012-08040	BOLT M8X40	2	2	2	2														
20	903-020-40801	WASHER, SPRING 8	2	2	2	2														
21	162-682-31000	LABEL	1	1	1	1														
30	323-700-09510	ROD ASSY	1	1	1	1														
31	323-700-02150	SPACER	1	1	1	1														
32	807-201-03014	PIN, SPRING 3X14	1	1	1	1														
50	333-700-08090	SWITCH ASSY (JIB&S/T)	1	1	1	1														

165

組立名称 シリンダマスタ
 Assembly Name CYLINDER, MASTER

FIG. PI103-0001-00

仕様番号 A < TL-250M-1-10101 > B < TL-250M-1-10102 > C < TL-250M-1-20101 >
 Specification No. D < TL-250M-1-20102 >

指示番号 Key No.	部品番号 Part No.	部品名称 Part Name	Q'ty Per Section 個数													実施号 (変更番号)	Serial No. Modifi. No.)	ページ Page	
			A	B	C	D	E	F	G	H	I	J	K	L	M				N
1	360-601-80002	CYLINDER, MASTER	1	1	1	1													
4	194-140-80040	STOPPER, SUPPLY VALVE	1	1	1	1													
7	194-140-80210	ROD, PUSH	1	1	1	1													
7	360-601-85040	ROD, PUSH	1	1	1	1											(340220 - 2008969 -)
15	360-600-75010	CAP, VALVE	1	1	1	1													
18	194-140-80170	BAND, RESERVOIR	1	1	1	1											(- 340219 - 2008969)
18	360-605-15010	BAND, RESERVOIR	1	1	1	1											(340220 - 2008969 -)
19	360-600-05010	NIPPLE	1	1	1	1													
30	360-601-85030	REPAIR KIT	1	1	1	1											(- 340219 - 2008969)
30	360-601-85031	REPAIR KIT	1	1	1	1											(340220 - 2008969 -)

組立名称
Assembly Name

バルブ,ソレノイド
VALVE,SOLENOID

FIG. PI112-0120-01

スペック番号
Specification No.

A < TL-250M-1-10101
D < TL-250M-1-20102

> B < TL-250M-1-10102
>

> C < TL-250M-1-20101
>

指示番号 Key No.	部品番号 Part No.	部品名称 Part Name	Q'ty Per Section 個数													実施号 (変更番号)	Serial No. Modifi. No.)	ページ Page	
			A	B	C	D	E	F	G	H	I	J	K	L	M				N
1	366-402-30000	VALVE,SOLENOID	1	1	1	1													
2	366-402-35010	VALVE,SOLENOID	1	1	1	1													
3	366-402-35020	PLUG	2	2	2	2													
4	366-402-35030	SPRING	2	2	2	2													
5	805-600-59000	BALL,STEEL YB5/16	2	2	2	2													
6	182-151-01190	PLUG	1	1	1	1													
7	910-021-01100	O,RING 1B P11	2	2	2	2													
9	901-315-04010	BOLT,HEXAGON SOCKET M4X10	1	1	1	1													
12	366-402-35050	COIL	1	1	1	1													
13	366-400-75020	NUT	1	1	1	1													
14	366-402-35060	CONNECTOR	1	1	1	1													
15	910-010-00800	O,RING S8	1	1	1	1													
16	910-005-01700	O,RING	1	1	1	1													
17	910-005-21100	O,RING ARP568-211	1	1	1	1													
18	910-011-02100	O,RING 1A P21	1	1	1	1													
19	910-010-03800	O,RING S38	1	1	1	1													
20	366-402-35040	BODY ASSY	1	1	1	1													

組立名称 カートリッジ・カウンタバランス
 Assembly Name CARTRIDGE, COUNTERBALANCE

FIG. P1126-0011-00

スペック番号 A < TL-250M-1-10101 > B < TL-250M-1-10102 > C < TL-250M-1-20101 >
 Specification No. D < TL-250M-1-20102 >

指示番号 Key No.	部品番号 Part No.	部品名称 Part Name	Q'ty Per Section 個数														実施号 (変更番号)	Serial No. Modifi. No.)	ページ Page	
			A	B	C	D	E	F	G	H	I	J	K	L	M	N				O
2	910-011-04400	O,RING 1A P44	3	3	3	3														
3	914-110-04400	RING,BACKUP P44	3	3	3	3														
6	162-651-53060	SPRING	1	1	1	1														
9	910-011-01600	O,RING 1A P16	1	1	1	1														
11	910-010-02200	O,RING 1A S22	1	1	1	1														
13	162-651-53130	SPRING-A	1	1	1	1														
14	162-651-53140	SPRING-B	1	1	1	1														
16	910-028-03000	O,RING 1B P30	1	1	1	1														
17	910-028-04000	O,RING 1B P40	1	1	1	1														
19	910-011-01250	O,RING 1B P12.5	1	1	1	1														
20	910-010-03150	O,RING 1A S31.5	1	1	1	1														
30	162-651-53000	CARTRIDGE, COUNTERBALANCE	1	1	1	1														

組立名称 オペレーションシステム、コントロールバルブ
 Assembly Name OPERATION SYSTEM, CONTROL VALVE

FIG. PL101-0043-02

仕様番号 A < TL-250M-1-10101 > B < TL-250M-1-10102 > C < TL-250M-1-20101 >
 Specification No. D < TL-250M-1-20102 >

指示番号 Key No.	部品番号 Part No.	部品名称 Part Name	Q'ty Per Section 個数													実施号 (変更番号)	Serial No. Modifi. No.)	ページ Page		
			A	B	C	D	E	F	G	H	I	J	K	L	M				N	O
154	370-014-00000	SPRING	1	-	1	-												(- 340180 - 2005682)	
155	370-001-01080	PIN	1	-	1	-												(340181 - (2005682 -)	
155	333-200-05200	SUPPORT	1	-	1	-												(340181 - (2005682 -)	
157	901-022-08040	BOLT M8X40	1	-	1	-												(- 340180 - 2005682)	
158	901-022-08012	BOLT M8X12	1	-	1	-												(- 340180 - 2005682)	
158	901-022-08012	BOLT M8X12	2	-	2	-												(340181 - (2005682 -)	
161	821-000-00229	CONNECTOR	1	-	1	-												(- 340291 - 2018336)	
161	821-000-00229	CONNECTOR	1	-	1	-												(340292 - (2018336 -)	
170	333-200-01440	NUT	1	-	1	-												(340136 - (2003857 -)	
170	333-200-01440	NUT	1	-	1	-												(340136 - (2003860 -)	
170	333-200-01440	NUT	1	-	1	-												(340136 - (2003861 -)	
170	333-200-01440	NUT	1	-	1	-												(340136 - (2003862 -)	
171	333-200-01081	LEVER	1	-	1	-												(340136 - (2003857 -)	
171	333-200-01081	LEVER	1	-	1	-												(340136 - (2003860 -)	
171	333-200-01081	LEVER	1	-	1	-												(340136 - (2003861 -)	
171	333-200-01081	LEVER	1	-	1	-												(340136 - (2003862 -)	
172	333-200-01450	SLEEVE	1	-	1	-												(340136 - (2003857 -)	
172	333-200-01450	SLEEVE	1	-	1	-												(340136 - (2003860 -)	
172	333-200-01450	SLEEVE	1	-	1	-												(340136 - (2003861 -)	
172	333-200-01450	SLEEVE	1	-	1	-												(340136 - (2003862 -)	
181	370-001-08440	PIN	1	-	1	-												(340181 - (2005674 -)	

組立名称 サイドガード インスタレーション
 Assembly Name SIDE GUARD INSTALLATION

FIG. PX120-0120-01

仕様番号 A < TL-250M-1-10101 > B < TL-250M-1-10102 > C < TL-250M-1-20101 >
 Specification No. D < TL-250M-1-20102 >

指示番号 Key No.	部品番号 Part No.	部品名称 Part Name	Q'ty Per Section 個数													実施号 (変更番号)	Serial No. Modifi. No.)	ページ Page							
			A	B	C	D	E	F	G	H	I	J	K	L	M				N	O					
1	337-701-28010	GUARD ASSY, SIDE	1	1	-	-												(340226	-	340226	-	2007404)	
1	337-701-28050	GUARD ASSY, SIDE	1	1	-	-												(340227	-	340227	-	2007404)	
4	903-020-41001	WASHER, SPRING 10	2	2	-	-												(340226	-	340226	-	2007404)	
4	903-020-41001	WASHER, SPRING 10	1	1	-	-												(340227	-	340227	-	2007404)	
5	563-600-13000	PLATE	12	12	-	-												(340226	-	340226	-	2007404)	
5	563-600-13000	PLATE	5	5	-	-												(340227	-	340227	-	2007404)	
6	901-012-10016	BOLT M10X16	2	2	-	-												(340226	-	340226	-	2007404)	
6	901-012-10016	BOLT M10X16	1	1	-	-												(340227	-	340227	-	2007404)	
7	337-701-28020	GUARD ASSY, SIDE	1	1	-	-												(340226	-	340226	-	2007404)	
7	337-701-28060	GUARD ASSY, SIDE	1	1	-	-												(340227	-	340227	-	2007404)	
8	337-701-28030	GUARD ASSY, SIDE	1	1	-	-												(340226	-	340226	-	2007404)	
8	337-701-28070	GUARD ASSY, SIDE	1	1	-	-												(340227	-	340227	-	2007404)	
9	337-701-28040	GUARD ASSY, SIDE	1	1	-	-												(340226	-	340226	-	2007404)	
9	337-701-28080	GUARD ASSY, SIDE	1	1	-	-												(340227	-	340227	-	2007404)	
11	902-012-01000	NUT M10	4	4	-	-												(340227	-	340227	-	2007404)	
12	370-005-04140	PLATE	4	4	-	-												(340227	-	340227	-	2007404)	
13	901-012-10030	BOLT M10X30	4	4	-	-												(340227	-	340227	-	2007404)	
21	337-700-58060	SUPPORT ASSY	2	2	-	-												(340226	-	340226	-	2007404)	
31	337-700-56000	SUPPORT	2	2	-	-												(340226	-	340226	-	2007404)	
15	337-700-57000	SUPPORT ASSY	3	3	-	-												(340227	-	340227	-	2007404)	
41	370-005-06440	SUPPORT	3	3	-	-												(340227	-	340227	-	2007404)	
42	901-012-10020	BOLT M10X20	6	6	-	-												(340227	-	340227	-	2007404)	
43	370-005-00880	PLATE	3	3	-	-												(340227	-	340227	-	2007404)	

250

スペック番号 A < TL-250M-1-10101 > B < TL-250M-1-10102 > C < TL-250M-1-20101 >
 Specification No. D < TL-250M-1-20102 >

指示番号 Key No.	部品番号 Part No.	部品名称 Part Name	Qty Per Section 個数													実施号 (変更番号)	Serial No. Modifi. No.)	ページ Page	
			A	B	C	D	E	F	G	H	I	J	K	L	M				N
1	366-900-05010	COVER	1	1	1	1													
2	901-022-06014	BOLT M6X14	8	8	8	8													
3	903-020-10600	WASHER,SPRING 6	8	8	8	8													
4	902-012-00600	NUT M6	8	8	8	8													
5	366-900-05020	SUPPORT	1	1	1	1													
6	366-900-05030	PLATE	1	1	1	1													- 340180
6	366-900-05031	PLATE	1	1	1	1													- 2011204)
7	366-900-05040	SUPPORT	1	1	1	1													(340181 -
8	901-022-08025	BOLT M8X25	4	4	4	4													(2011204 -)
9	903-020-10800	WASHER,SPRING 8	12	12	12	12													
10	805-160-06005	BEARING,BALL 6005ZZ	2	2	2	2													
11	806-011-10250	RING,RETAINING S25	1	1	1	1													
12	806-021-10470	RING,RETAINING R47	2	2	2	2													
13	366-900-05050	FAN	1	1	1	1													
14	366-900-05060	COUPLING	1	1	1	1													- 340180
14	366-900-05061	COUPLING	1	1	1	1													(- 2011204)
15	901-022-08012	BOLT M8X12	4	4	4	4													340181 -
16	363-300-00000	RADIATOR	1	1	1	1													(2011204 -)
16	363-300-00001	RADIATOR	1	1	1	1													- 340252
17	901-012-10085	BOLT M10X85	4	4	4	4													(- 2013045)
18	903-020-11000	WASHER,SPRING 10	4	4	4	4													
19	902-012-01000	NUT M10	4	4	4	4													
20	366-600-10000	MOTOR ASSY,HYDRAULIC	1	1	1	1													
21	901-022-08020	BOLT M8X20	4	4	4	4													
27	912-521-01400	SEAL,OIL TCV14287	1	1	1	1													
28	910-022-05000	O,RING 18 G50	1	1	1	1													
30	901-315-08020	BOLT,HEXAGON SOCKET M8X20	6	6	6	6													
31	903-020-40801	WASHER,SPRING 8	6	6	6	6													
33	809-566-03130	KEY PM3X13	1	1	1	1													
34	806-021-10280	RING,RETAINING R28	1	1	1	1													

265

変更番号 Modifi. No.	実施号機 Serial No.	組立名称 Assembly Name	ページ Page	旧部品 Old Parts ← 新部品 New Parts						
				指示番号 Key No.	部品番号 Part No.	個数 Q'ty	指示番号 Key No.	部品番号 Part No.	個数 Q'ty	
2005566	340181-	フロント シヤツキ,メカニカル FRONT JACK, MECHANICAL	146	1	370-002-00100	1	1	370-002-00540	1	
				3	337-300-00040	1	3	337-300-00041	1	
				4	564-210-33000	1	4	337-300-00320	1	
2005603	340181-	パイピング,アウトリガ PIPING,OUTRIGGER	138	33	803-030-10100	10	42	803-010-10100	14	
				42	803-010-10100	4	45	370-007-00400	1	
				45	370-007-00400	3	47	594-570-19000	4	
				47	370-007-02770	4	52	336-412-00500	3	
				52	370-005-05890	4	53	370-007-03180	2	
2005607	340181-	パイピング,アウトリガ PIPING,OUTRIGGER	134	42	803-010-10100	4	42	803-010-10100	14	
				47	370-007-02770	4	47	594-570-19000	4	
				50	803-030-10100	10	51	336-412-00500	3	
				51	370-005-05890	4	52	370-007-03180	2	
2005619	340181-	ジョイント,ロータリー JOINT,ROTARY	88	3	912-501-00050	1	4	336-300-30020	1	
				4	336-300-10010	1	110	336-300-30040	1	
				51	336-300-00130	1	115	326-300-10070	2	
				52	336-300-00140	1				
				110	336-300-10050	1				
2005660	340181-	キャブ,オペレータ CAB,OPERATOR'S	404	16	332-600-00080	7	17	901-015-08050	5	
				17	901-315-08050	5	23	370-005-06530	5	
				23	370-005-04360	5	24	370-005-06540	5	
				24	370-005-04370	5	25	370-005-06550	5	
				25	370-005-04380	5	138	903-091-50401	6	
				138	903-090-50401	8	139	824-000-00055	4	
				139	824-000-00055	6	180	901-015-08050	5	
				180	901-315-08050	5	181	903-030-71201	13	
				181	903-030-71201	6				
				2005674	340181-	オペレーション システム,コントロール ハルブ OPERATION SYSTEM, CONTROL VALVE	418	95	370-001-01070	4
96	901-315-10020	8	96					901-315-10016	4	
97	903-020-41001	8	97					903-020-41001	4	
99	333-200-44200	1	99					333-200-44201	1	
2005675	340181-	オペレーション システム,コントロール ハルブ OPERATION SYSTEM, CONTROL VALVE	418	51	333-200-42100	1	51	333-200-42101	1	
				56	901-012-10020	2				
				57	903-020-41001	2				
				58	333-200-42300	1				
				2005676	-340180	オペレーション システム,コントロール ハルブ OPERATION SYSTEM,CON TROL VALVE	418	31	333-200-00120	3
32	902-912-01200	3								
424	44	902-912-01200	2							
	45	333-200-00120	2							
2005677	340181-	オペレーション システム,コントロール ハルブ OPERATION SYSTEM, CONTROL VALVE	418	34	902-012-01200	3	35	333-200-00100	3	
				81	333-200-00900	3	82	902-032-01200	3	
				424	42	902-012-01200	4	41	333-200-00100	4
					101	333-200-00900	4	102	902-032-01200	4
2005678	340181-	オペレーション システム,コントロール ハルブ OPERATION SYSTEM, CONTROL VALVE	418	41	333-200-01400	1	41	313-200-20071	1	
				42	902-012-00800	2	42	902-012-00800	1	
				43	333-200-01410	1	44	370-001-00070	1	
				44	370-001-01040	1	45	801-360-20010	1	
	424	17	902-012-00800	2	17	902-012-00800	1			
		61	333-200-01400	1	61	313-200-20071	1			
		63	333-200-01410	1	64	370-001-00070	1			
		64	370-001-01040	1	65	801-360-20010	1			
2005682	340181-	オペレーション システム,コントロール ハルブ OPERATION SYSTEM, CONTROL VALVE	418	55	903-020-40801	1	55	903-020-40801	2	
				152	333-200-00210	1	152	333-200-05100	1	
				153	333-200-00220	1	153	333-200-00221	1	
				155	370-001-01080	1	155	333-200-05200	1	

インデックス
INDEX

部 品 番 号 Part No.	頁 Page	指示番号 Key No.	部 品 番 号 Part No.	頁 Page	指示番号 Key No.	部 品 番 号 Part No.	頁 Page	指示番号 Key No.
						803-050-50100	219	83
801-763-04010	440	94	803-020-10160	139	36			
	493	21		218	82		222	83
801-763-04012	406	93		222	82	803-060-10060	87	12
801-763-04014	440	91	803-020-10240	509	27		218	67
801-763-04020	439	19	803-020-90101	327	8	803-070-30140	222	67
801-763-05016	407	133	803-020-90161	135	39		226	67
801-833-06016	125	75		139	39		230	67
801-851-08016	451	6	803-020-90241	63	19	803-070-30160	87	1
	453	6		67	19	803-090-10060	87	11
802				135	37	803-110-10080	218	59
802-050-00400	183	35		139	37		222	59
	186	50		509	23		226	59
802-050-01000	57	13	803-030-10080	217	9		230	59
				225	9	803-110-10120	219	84
803				136	50		222	84
803-010-10060	175	15	803-030-10100	139	33	803-130-10060	183	51
803-010-10080	221	9		63	20		186	52
	229	9	803-030-10160	67	20	803-130-10100	509	30
803-010-10100	135	42		75	29	803-150-20140	297	27
	140	42	803-030-10241	225	30	803-160-30000	349	10
803-010-10160	139	41	803-030-30060	217	21	803-160-30020	53	43
803-010-10241	71	30	803-030-30080	221	21		96	94
	75	30		225	21		106	94
803-010-50040	217	38		229	21		112	164
	221	38		217	13		151	9
	225	38	803-030-30100	221	13		157	89
	229	38		225	13		165	89
803-020-10060	175	10		229	13		217	22
	217	26		297	26		221	22
	221	26		219	85		237	15
805-	225	26	803-030-30160	222	85		239	13
	229	26		181	4		271	85
806-01	175	14	803-030-50160	297	8		369	20
	217	17		135	35		369	58
	221	17	803-050-10160	139	35		79	18
806-011	225	17		217	23	803-160-30040	83	18
806-011-	229	17	803-050-30020	221	23		87	16
	217	19		225	23		94	31
806-011-1	221	19		229	23		99	22
	225	19		217	37		104	32
806-011-10	229	19	803-050-50080	221	37		110	3
	297	25		225	37		223	10
806-011-103	327	10		229	37		225	2
		135	803-020-10160					

部 品 番 号 Part No.	頁 Page	指示番号 Key No.	部 品 番 号 Part No.	頁 Page	指示番号 Key No.	部 品 番 号 Part No.	頁 Page	指示番号 Key No.
901-012-10020	193	8	901-012-12030	509	15	901-015-12025	256	108
	281	7	901-012-12035	379	18		257	171
	297	32	901-012-12040	157	92	901-015-12028	258	217
	412	81				901-015-12030	399	16
	421	56	901-012-12050	219	97		405	14
	427	76		223	97	901-015-14025	246	51
	475	9		226	73		250	51
	510	40		230	73	901-015-16035	191	9
901-012-10022	119	19	901-012-12055	256	97		195	16
	246	40	901-012-12060	256	97	901-015-16040	189	14
	250	40	901-012-12085	159	350	901-015-16055	245	30
901-012-10025	49	10		167	350		249	30
	51	10	901-012-14045	55	21	901-015-16065	155	17
	55	9	901-012-14050	485	2			
	57	9		487	2	901-015-16085	155	17
	59	12	901-012-16045	156	49		163	17
	61	12		164	49	901-015-16140	255	50
	127	13	901-012-16055	156	50	901-015-18050	245	12
	128	108		164	50		249	12
	131	13	901-014-08016	71	14	901-015-20070	245	5
	132	74		71	15		249	5
	171	22		75	15	901-017-10016	201	1
	246	39		116	85	901-017-10030	53	39
	250	39	901-015-08015	405	8	901-017-12035	53	20
	417	14	901-015-08020	157	83	901-017-16075	115	12
901-012-10030	115	26		165	83	901-017-18050	53	21
	205	69	901-015-08035	205	62	901-022-05012	327	13
	285	16	901-015-08050	405	17	901-022-06012	406	68
	411	29		408	180	901-022-06014	513	2
	412	51	901-015-10016	266	304	901-022-08010	149	16
	483	13	901-015-10020	254	14	901-022-08012	203	20
901-012-10065	89	30	901-015-10030	67	41		399	13
901-012-10085	513	17		254	23		423	158
901-012-12016	491	9		399	3		427	58
901-012-12020	257	174	901-015-10040	119	17		513	15
901-012-12025	277	23	901-015-10055	115	5	901-022-08014	298	45
901-012-12030	59	6	901-015-12018	257	157	901-022-08016	204	54
	61	6	901-015-12020	246	51		263	10
	219	96		250	51		406	66
	223	96		258	200	901-022-08020	513	21
	226	72	901-015-12022	263	30	901-022-08025	513	8
	230	72	901-015-12025	254	34	901-022-08035	128	72
	383	22		256	92		132	75

CLICK HERE TO **DOWNLOAD** THE COMPLETE MANUAL

- Thank you very much for reading the preview of the manual.
- You can download the complete manual from: www.heydownloads.com by clicking the link below



- Please note: If there is no response to CLICKING the link, please download this PDF first and then click on it.

CLICK HERE TO **DOWNLOAD** THE COMPLETE MANUAL