



TADANO

HYDRAULIC CRANE PARTS CATALOG

MODEL TL-200M-1

**INFORMATION No. TL-200M-11/P-01
SERIAL No. 331101**

**Used Crane Specialist
Sales, Service & Parts
Manufacture Support**

CLICK HERE TO **DOWNLOAD** THE COMPLETE MANUAL

- Thank you very much for reading the preview of the manual.
- You can download the complete manual from: www.heydownloads.com by clicking the link below



- Please note: If there is no response to CLICKING the link, please download this PDF first and then click on it.

CLICK HERE TO **DOWNLOAD** THE COMPLETE MANUAL

目次
CONTENTS

TL-200M 目次 CONTENTS

スペック番号 Specifications No.	A<	> B<	> C<	>
	D<	> E<	> F<TL-200M-1-11004	>
G<	> H<	> I<	> J<	>
K<	> L<	> M<	> N<	>
O<	> P<	> Q<	> R<	>
S<	> T<	> U<	> V<	>
W<	> X<	> Y<	> Z<	>

指示番号 Key No.	組立名称 Assembly Name	(組立番号 Assembly No.) (管理番号 Control No.)	個数欄 Page Qty Per Section Column
12	バルブ, チェック VALVE, CHECK	192-251-21000 (PI114-001)	
	A B C D E F G H I J K L M N O P Q R S T U V W X Y Z 1 1 - - - - - - - - - 1 1 - - -		
13	バルブ, パイロットチェック VALVE, PILOT CHECK	366-200-00000 (PI128-005)	196-a
	A B C D E F G H I J K L M N O P Q R S T U V W X Y Z 4 4 4 4 4 4 4 4 4 4 4 4 4 4 4 4		
13	バルブ, パイロットチェック VALVE, PILOT CHECK	366-202-60000 (PI128-010)	198-a
	A B C D E F G H I J K L M N O P Q R S T U V W X Y Z 4 4 4 4 4 4 4 4 4 4 4 4 4 4 4 4		
	()		
	A B C D E F G H I J K L M N O P Q R S T U V W X Y Z		
	()		
	A B C D E F G H I J K L M N O P Q R S T U V W X Y Z		
	()		
	A B C D E F G H I J K L M N O P Q R S T U V W X Y Z		
	()		
	A B C D E F G H I J K L M N O P Q R S T U V W X Y Z		
	()		
	A B C D E F G H I J K L M N O P Q R S T U V W X Y Z		
	()		
	A B C D E F G H I J K L M N O P Q R S T U V W X Y Z		
	()		
	A B C D E F G H I J K L M N O P Q R S T U V W X Y Z		

組立名称 タンク,オイル Assembly Name TANK,OIL														
組立番号 a < 336-600-10000 > b < 336-600-30000 > c < 336-600-40000 > Assembly No. d < 336-601-00000 > e < > f < > g < > h < > i < > j < >														
指示番号 Key No.	部品番号 Part No.	部品名称 Part Name	Q'ty Per Section 個数											備考 Remarks
			a	b	c	d	e	f	g	h	i	j		
1	336-600-00210	GAUGE,OIL	1	1	1	1								
3	563-566-00010	O,RING	1	1	1	1								
4	336-600-00170	COVER	1	1	1	1								
5	336-600-00220	BREATHER ASSY	1	1	1	1								
6	903-020-41001	WASHER,SPRING 10	12	12	12	12								
7	901-012-10016	BOLT M10X16	8	8	8	8								
8	903-030-71001	WASHER,PLAIN 10	4	4	4	4								
9	901-012-10025	BOLT M10X25	4	4	4	4								
10	366-700-30000	FILTER,OIL	1	1	1	1								SEE PI130-007
11	336-600-00240	GUARD	1	1	1	1								
12	336-600-00230	PLUG ASSY	1	1	1	1								
21	901-012-14045	BOLT M14X45	1	1	1	1								
22	336-600-05020	PACKING	4	4	4	4								
23	336-600-05010	GAUGE	1	1	1	1								
25	336-600-10000	TANK ASSY,OIL	1	-	-	-								
25	336-600-30000	TANK ASSY,OIL	-	1	-	-								
25	336-600-40000	TANK ASSY,OIL	-	-	1	-								
25	336-601-00000	TANK ASSY,OIL	-	-	-	1								

34

組立名称 771111
 Assembly Name OTRIGGER

組立番号 a < 336-100-20000 > b < 336-100-70000 > c < 336-100-30000 >
 Assembly No. d < > e < > f < >
 g < > h < > i < > j < >

指示番号 Key No.	部品番号 Part No.	部品名称 Part Name	Q'ty Per Section 個数											備考 Remarks		
			a	b	c	d	e	f	g	h	i	j				
70	336-100-73900	SUPPORT	-	2	-											
83	902-012-00800	NUT M8	-	4	-											
84	903-020-40801	WASHER, SPRING 8	-	4	-											
85	901-014-08016	BOLT M8X16	-	4	-											
86	564-821-46000	CLAMP	-	4	-											
87	560-571-21000	SUPPORT	-	4	-											
94	903-020-41001	WASHER, SPRING 10	8	-	-											
96	337-603-00200	SUPPORT	2	-	-											
97	901-012-10012	BOLT M10X12	8	-	-											
98	337-603-00300	COVER	2	-	-											
99	337-603-00400	SUPPORT	2	-	-											

50

組立名称 フロントジャック・インストール Assembly Name FRONTJACK, INSTALLATION																	
組立番号 Assembly No.		a < 337-300-00000 > d < 337-300-80000 > g < >			b < 337-300-10000 > e < 337-301-71000 > i < >			c < 337-300-30000 > f < 337-301-61000 > j < >									
指示番号 Key No.	部品番号 Part No.	部品名称 Part Name	Q'ty Per Section 個数										備考 Remarks				
			a	b	c	d	e	f	g	h	i	j					
1	337-300-00010	SUPPORT	1	-	-	1	-	-									
1	337-300-10010	SUPPORT	-	1	1	-	-	-									
1	337-301-71100	SUPPORT	-	-	-	-	-	1	-								
1	337-301-61100	SUPPORT	-	-	-	-	-	-	1								
2	370-001-02160	PIN	1	1	1	1	1	1	1								
3	337-300-00020	FRONTJACK, MECHANICAL	1	1	1	1	1	1	1								SEE PC127-001
4	563-210-02000	SUPPORT	1	-	-	1	1	-									
4	563-212-02000	SUPPORT	-	1	1	-	-	1									
5	370-001-02180	PIN	1	1	1	1	1	1	1								
6	901-012-06020	BOLT M6X20	2	2	2	2	2	2	2								
7	902-032-00600	NUT M6	2	2	2	2	2	2	2								
8	903-030-70601	WASHER,PLAIN 6	1	1	1	1	1	1	1								
9	337-300-00140	LINK	1	1	1	1	1	1	1								
10	536-441-11000	PIN	1	1	1	1	1	1	1								
11	563-468-37000	LEVER	1	1	1	1	1	1	1								
12	807-201-05030	PIN,SPRING 5X30	1	1	1	1	1	1	1								
13	903-030-71601	WASHER,PLAIN 16	2	2	2	2	2	2	2								
14	902-362-51601	NUT,CASTLE M16	1	1	1	1	1	1	1								
15	801-360-40030	PIN,SPLIT 4X30	2	2	2	2	2	2	2								
16	536-412-01000	CABLE,CONTROL	1	1	1	1	-	-									
16	565-401-22000	CABLE,CONTROL	-	-	-	-	1	1									
17	191-144-11000	SPRING	1	1	1	1	1	1	1								
18	337-300-00170	LINK	1	1	1	1	1	1	1								
19	337-300-08020	SUPPORT ASSY	1	-	-	1	-	-									
19	337-300-18010	SUPPORT ASSY	-	1	-	-	-	-									
19	337-300-38010	SUPPORT ASSY	-	-	1	-	-	1									
19	337-300-88010	SUPPORT ASSY	-	-	-	-	-	1	-								
20	370-007-00910	CLAMP ASSY	11	11	11	11	9	9									
24	121-145-41001	PIN	1	1	1	1	1	1	1								
25	563-467-82000	FORK	1	1	1	1	1	1	1								
26	903-030-70801	WASHER,PLAIN 8	1	1	1	1	1	1	1								
27	801-360-25015	PIN,SPLIT 2.5X15	1	1	1	1	1	1	1								
28	337-300-00240	STOPPER	1	1	1	1	1	1	1								
30	370-002-00100	PIN,SNAP	1	1	1	1	1	1	1								
31	569-460-31000	SPACER	-	-	1	1	1	1	1								
32	337-300-08010	LINK,ASSY	1	1	1	1	1	1	1								

60

組立名称 トライヒックTM ニフト、スイング
 Assembly Name DRIVING UNIT, SWING

組立番号 a < 194-151-07000 > b < 360-800-00000 > c < 360-800-20000 >
 Assembly No. d < 360-800-40000 > e < 360-800-70000 > f < >
 g < > h < > i < > j < >

指示番号 Key No.	部品番号 Part No.	部品名称 Part Name	Q'ty Per Section 個数										備考 Remarks	
			a	b	c	d	e	f	g	h	i	j		
35	183-351-16390	COVER,OIL SEAL	1	1	1	1	1							
36	806-011-10450	RING,RETAINING S45	1	1	1	1	1							
37	166-233-20190	SPRING,PLUNGER	9	9	9	9	9							
38	183-351-16410	SEAT,SPRING	9	9	9	9	9							
39	183-351-16420	SEAT,SPRING	9	9	9	9	9							
40	366-601-75010	SPRING,CENTER	1	1	1	1	1							
41	806-021-10620	RING,RETAINING R62	1	1	1	1	1							
42	190-451-05190	SEAT,CENTER SPRING	1	1	1	1	1							
43	183-351-16440	SEAT,SPRING	1	1	1	1	1							
44	807-201-13025	PIN,SPRING 13X25	2	2	2	2	2							
46	141-451-01021	O,RING	1	1	1	1	1							
47	183-351-16460	BEARING,NEEDLE	1	1	1	1	1							
48	194-151-07050	COVER,BOTTOM	1	1	1	1	1							
49	901-315-16045	BOLT,HEXAGON SOCKET M16X45	7	7	7	7	7							
50	901-017-16055	BOLT M16X55	1	1	1	1	1							
51	903-020-41601	WASHER,SPRING 16	7	7	7	7	7							
52	183-351-16490	O,RING S63	1	1	1	1	1							
53	141-451-01011	SEAL,OIL NOK ISP385811	1	1	1	1	1							
54	183-351-16510	COVER,OIL SEAL	1	1	1	1	1							
55	901-315-08020	BOLT,HEXAGON SOCKET M8X20	4	4	4	4	4							
56	903-020-40801	WASHER,SPRING 8	4	4	4	4	4							
57	807-301-00025	PIN,STRAIGHT 10X25	2	2	2	2	2							
58	183-351-16520	RING,RETAINING NTN BR48	1	1	1	1	1							
59	183-351-16530	BOLT	4	4	4	4	4							
60	903-020-41001	WASHER,SPRING 10	8	8	8	8	8							
61	806-011-10360	RING,RETAINING S36	1	1	1	1	1							
62	194-151-07070	PLATE ASSY,BACK	1	1	1	1	1							
63	183-351-95060	SHOE ASSY,BRAKE	2	2	2	2	2							
64	183-351-16550	PIN,ANCHOR	1	1	1	1	1							
65	902-012-01200	NUT M12	1	1	1	1	1							
66	903-020-41201	WASHER,SPRING 12	1	1	1	1	1							
67	183-351-16570	PLATE,SHOE GUIDE	1	1	1	1	1							
68	183-351-16580	SPRING,SHOE RETURN	2	2	2	2	2							
69	183-351-95070	ADJUSTER ASSY	1	1	1	1	1							
70	183-351-16590	SPRING,ADJUSTING	1	1	1	1	1							
73	183-351-16620	LEVER,BRAKE	1	1	1	1	-							
73	366-601-75030	LEVER,BRAKE	-	-	-	-	1							
74	183-351-16630	LINK	1	1	1	1	-							
74	366-601-75040	LINK	-	-	-	-	1							
75	183-351-16640	PIN,BRAKE LEVER	3	3	3	3	3							

組立名称 シリンダ、エレベーター
 Assembly Name CYLINDER, ELEVATING

組立番号 a < 360-200-70000 > b < 360-201-30000 > c < 360-201-50000 >
 Assembly No. d < 360-202-90000 > e < > f < >
 g < > h < > i < > j < >

指示番号 Key No.	部品番号 Part No.	部品名称 Part Name	Q'ty Per Section 個数											備考 Remarks	
			a	b	c	d	e	f	g	h	i	j			
1	807-201-05040	PIN, SPRING	1	1	1	1									
2	916-840-21500	PACKING SGY215	2	-	-	-									
2	915-003-27004	PACKING NOK ODI 270X250X12	-	2	-	-									
2	916-840-27000	PACKING SGY270	-	2	-	-									
2	916-840-21000	PACKING SGY210	-	-	2	2									
3	914-112-19500	RING, BACKUP TC 215X195X2.5	2	-	-	-									
3	166-162-09001	RING, BACKUP NOK 250X270X4	-	1	-	-									
3	914-112-24500	RING, BACKUP TC 270X245X3	-	2	-	-									
3	914-112-19000	RING, BACKUP TC 210X190X2.5	-	-	1	2									
4	910-021-14500	O, RING 1BP145	1	-	1	1									
4	910-021-17500	O, RING 1BP175	-	1	-	-									
5	360-200-70101	PISTON	1	-	-	-									
5	360-201-30100	PISTON	-	1	-	-									
5	360-201-30101	PISTON	-	1	-	-									
5	360-201-50100	PISTON	-	-	1	1									
6	910-028-20000	O, RING P200	1	-	-	-									
6	910-028-25500	O, RING P255	-	1	-	-									
6	910-029-20000	O, RING G200	-	-	1	1									
7	360-200-20041	COVER ASSY, ROD	1	-	-	-									
7	360-201-30200	COVER ASSY, ROD	-	1	-	-									
7	360-201-30201	COVER ASSY, ROD	-	1	-	-									
7	360-201-50200	COVER ASSY, ROD	-	-	1	1									
9	916-941-17004	PACKING IUM170X190X12.5	1	-	-	-									
9	916-941-21000	PACKING SNY 210X230X12	-	1	-	-									
9	916-941-21004	PACKING IUM210X230X12	-	1	-	-									
10	914-102-17004	RING, BACKUP BRT3 170	1	-	-	-									
10	914-102-21002	RING, BACKUP TE 230X210X2.5	-	1	-	-									
10	914-102-21006	RING, BACKUP BRT3 210	-	1	-	-									
11	360-200-20070	COVER, HEAD	1	-	-	-									
11	360-201-30300	COVER, HEAD	-	1	-	-									
11	360-201-50300	COVER, HEAD	-	-	1	1									
12	910-012-19500	O, RING 1A G195	1	-	1	1									

70

CLICK HERE TO **DOWNLOAD** THE COMPLETE MANUAL

- Thank you very much for reading the preview of the manual.
- You can download the complete manual from: www.heydownloads.com by clicking the link below



- Please note: If there is no response to CLICKING the link, please download this PDF first and then click on it.

CLICK HERE TO **DOWNLOAD** THE COMPLETE MANUAL

組立名称 ハイロック、ウィンチ Assembly Name PIPING, WINCH														
組立番号 a < 333-409-70000 > b < 333-409-50000 > c < > Assembly No. d < > e < > f < > g < > h < > i < > j < >														
指示番号 Key No.	部品番号 Part No.	部品名称 Part Name	Qty Per Section 個数										備考 Remarks	
			a	b	c	d	e	f	g	h	i	j		
1	136-474-52000	HOSE	1	1										
2	303-200-20050	FITTING KUF10-020N	1	1										
3	903-041-11601	WASHER, TOOTH 16	1	1										
4	370-005-04800	SUPPORT	1	1										
5	814-080-00130	PIPE, STEEL 10	2M	2M										
6	370-007-02200	CLAMP ASSY	1	1										
7	803-030-10080	FITTING, ELBOW KLA10-000N	1	1										
8	370-007-02210	CLAMP ASSY	1	1										
9	370-003-00720	SLEEVE	2	2										
10	901-915-10035	BOLT M10X35	8	8										
11	903-020-41001	WASHER, SPRING 10	8	8										
12	370-024-01040	HOSE	1	1										
13	370-024-01050	HOSE	1	1										
14	814-080-00130	PIPE, STEEL 10	2M	2M										
15	333-400-31000	HOSE 9.54X12.7	1M	1M										
16	333-400-31050	HOSE 4.31X6.35	1M	1M										
17	333-400-31050	HOSE 4.31X6.35	1M	1M										
18	804-001-60112	FITTING, ELBOW 20369-U1/2X1/2	2	2										
19	804-001-60106	FITTING 20368-U1/2X1/2	2	2										
20	804-001-60102	FITTING 20368-U1/4X1/4	3	3										
21	804-001-60118	FITTING 20376-U1/4X1/4	1	1										
22	194-153-16001	JOINT	1	1										
23	821-000-01173	CLAMP ASSY	2	1										
24	814-080-00160	PIPE, STEEL 12	1M	1M										
25	814-080-00160	PIPE, STEEL 12	1M	1M										
26	814-080-00081	PIPE, STEEL 8	1M	1M										
27	814-080-00081	PIPE, STEEL 8	1M	1M										
28	814-080-00081	PIPE, STEEL 8	2M	2M										
29	814-080-00081	PIPE, STEEL 8	1M	1M										
30	814-080-00081	PIPE, STEEL 8	1M	1M										
31	814-080-00081	PIPE, STEEL 8	1M	1M										
32	814-080-00130	PIPE, STEEL 10	1M	1M										
33	803-030-30080	FITTING, ELBOW KLNC8-020N	1	1										
34	803-020-10160	FITTING KCT12-030N	1	1										
35	803-050-50100	FITTING, TEE KTK12-030N	1	1										
36	803-110-10120	FITTING KRE12X08CN	1	1										
37	803-050-30020	FITTING TEE KTN08-020N	1	1										
38	803-020-10060	FITTING KCT08-010N	3	3										
39	803-020-10080	FITTING KCT08-020N	3	3										
40	803-030-30160	FITTING, ELBOW KLN12-030N	2	2										

80

組立名称 7-6 Assembly Name B00M														
組立番号 a < 332-000-30000 > b < 332-000-70000 > c < 332-000-30001 > Assembly No. d < > e < > f < > g < > h < > i < > j < >														
指示番号 Key No.	部品番号 Part No.	部品名称 Part Name	Q'ty Per Section 個数										備考 Remarks	
			a	b	c	d	e	f	g	h	i	j		
103	332-000-39510	ROLLER ASSY	1	1	1									
104	805-150-06206	BEARING,BALL 6206Z	4	4	4									
105	806-011-10300	RING,RETAINING S30	3	3	3									
106	332-000-39520	ROLLER ASSY	1	1	1									
107	370-001-02050	PIN	1	1	1									
108	901-015-12025	BOLT M12X25	4	4	4									
109	903-020-41201	WASHER,SPRING 12	4	4	4									
111	332-000-34710	SUPPORT	1	1	1									
112	370-020-00250	PLATE,SLIDE	3	3	3									
113	901-315-08020	BOLT,HEXAGON,SOCKET M8X20	3	3	3									
121	901-012-10014	BOLT M10X14	4	4	4									
122	903-020-41001	WASHER,SPRING 10	4	4	4									
123	370-003-00350	SPACER	4	4	4									
124	370-001-02280	PIN	2	2	2									
125	370-010-00380	SHEAVE ASSY	2	2	2									
126	370-001-01310	PIN	2	2	2									
127	370-011-00170	ROLLER ASSY	2	2	2									
128	334-400-90020	SUPPORT	1	1	1									
131	334-400-90010	ROLLER ASSY	1	1	1									
133	334-400-90110	GUARD	1	1	1									
136	334-400-90120	BAR	2	-	-									
136	334-401-51010	BAR	-	4	2									
137	334-400-90150	SUPPORT	2	2	2									
138	334-400-90200	SUPPORT	2	2	2									
139	334-400-90250	BAR	2	-	-									
139	334-401-51010	BAR	-	-	2									
142	806-121-11250	RING,RETAINING AR125	6	6	6									
143	805-150-06214	BEARING,BALL 6214Z	12	12	12									
144	805-200-45013	BEARING,ROLLER	2	2	2									
151	902-034-01600	NUT M16	1	1	1									
152	902-014-01600	NUT M16	1	1	1									
153	332-000-00100	SUPPORT	1	1	1									
154	370-010-00150	SHEAVE	1	1	1									
155	370-001-00800	PIN	1	1	1									
156	806-011-10250	RING,RETAINING S25	1	1	1									
157	901-015-12018	BOLT M12X18	4	4	4									
158	903-020-41201	WASHER,SPRING 12	5	5	5									
159	332-000-00110	SUPPORT	1	1	1									
162	806-021-10900	RING,RETAINING R90	2	2	2									
163	805-160-06308	BEARING,BALL 6308Z	2	2	2									

90

組立名称 シリンダ、テレスコピック Assembly Name CYLINDER,TELESCOPING														
組立番号 a < 332-100-30000 > b < 332-100-70000 > c < 332-100-30001 > Assembly No. d < > e < > f < > g < > h < > i < > j < >														
指示番号 Key No.	部品番号 Part No.	部品名称 Part Name	Q'ty Per Section 個数										備考 Remarks	
			a	b	c	d	e	f	g	h	i	j		
40	903-020-40801	WASHER,SPRING 8	6	6	6									
41	332-100-00650	WIRE 1X300	3	3	3									
44	804-306-20600	JOINT	1	1	1									
45	910-021-01800	O,RING 1B P18	3	3	3									
46	803-200-50100	JOINT HC804-040B	1	1	1									
47	370-024-00540	HOSE	1	1	1									
48	332-100-30030	JOINT,SELFSEAL	1	1	1									
50	805-160-06204	BEARING,BALL 6204ZZ	4	4	4									
52	806-021-10470	RING,RETAINING R47	2	2	2									
61	360-100-90020	CYLINDER	1	-	1									
61	360-101-60020	CYLINDER	-	1	-									
62	807-201-05025	PIN,SPRING 5X25	1	1	1									
63	370-016-00020	NUT	1	1	1									
64	370-004-00110	BEARING,PLAIN	2	2	2									
64	913-022-13000	BEARING,PLAIN	2	-	2									
65	916-841-13000	PACKING SGY130X115X8	2	2	2									
66	914-312-11500	RING,BACKUP	2	2	2									
67	360-100-90100	PISTON	1	1	2									
68	910-022-09500	O,RING 1B G95	1	1	2									
69	360-100-90200	ROD	1	-	-									
69	360-101-60200	ROD	-	1	-									
69	360-100-90201	ROD	-	-	1									
70	910-029-13000	O,RING G130	1	1	1									
71	370-004-00050	BEARING,PLAIN	2	-	-									
72	360-100-90500	SUPPORT	1	1	1									
73	360-100-20460	COVER,ROD	1	-	-									
73	360-100-20550	COVER,ROD	1	1	-									
73	360-100-20551	COVER,ROD	1	1	1									
74	912-511-01150	RING,DAMPER PGRI-115	1	1	1									
75	916-941-11500	PACKING SNY,130X115X8.5	1	1	1									
77	916-600-11500	SEAL,DUST SC3115	1	1	1									
78	360-100-20500	RETAINER	1	1	1									
79	360-100-90600	PLATE	2	2	2									
80	166-160-16000	PLATE	1	1	1									
81	901-315-06014	BOLT,HEXAGON SOCKET M6X14	4	4	4									
82	903-020-40601	WASHER,SPRING 6	4	4	4									
83	160-760-04000	PLUG	1	1	1									
84	914-302-11502	RING,BACKUP TE130X115X3	1	-	-									
84	914-102-11502	RING,BACKUP TE130X115X2	1	1	1									
85	803-160-30020	PLUG STPA1/8	1	1	1									

25

組立名称 ナイフタ,フーム レンクス
 Assembly Name DETECTOR,BOOM LENGTH

組立番号 a < 361-300-40000 > b < 361-300-50000 > c < 361-300-60000 >
 Assembly No. d < 361-300-80000 > e < 361-300-70000 > f < >
 g < > h < > i < > j < >

指示番号 Key No.	部品番号 Part No.	部品名称 Part Name	Q'ty Per Section 個数											備考 Remarks	
			a	b	c	d	e	f	g	h	i	j			
1	361-300-45010	PLATE	1	1	1	1	1								
2	361-300-45020	CASE	1	1	1	1	1								
3	361-300-45030	DRUM ASSY	1	1	1	1	1								
4	183-386-95520	RING ASSY,SLIP	1	1	1	1	1								
5	333-700-25170	CONTACT ASSY	1	1	1	1	1								
6	361-300-45170	CONTACT ASSY	1	1	1	1	1								
7	361-300-45180	CASE, BEARING	1	1	1	1	1								
8	805-150-06002	BEARING 6002Z	2	2	2	2	2								
9	806-011-10150	RING, RETAINING S15	1	1	1	1	1								
10	806-021-10320	RING, RETAINING R32	1	1	1	1	1								
11	323-600-05080	REDUCER	1	1	1	1	-								
11	361-300-15050	REDUCER	-	-	-	-	1								
12	361-300-45040	GEAR	1	1	1	1	1								
13	361-300-45050	GEAR	1	1	1	1	1								
14	361-300-45060	BRACKET	1	1	1	1	-								
14	361-300-15060	BRACKET	-	-	-	-	1								
15	361-300-45070	POTENTIONMETER	1	1	1	1	1								
16	323-600-05130	SPRING	1	1	1	1	-								
16	361-300-15070	SPRING	-	-	-	-	1								
17	361-300-45080	COVER	1	1	1	1	1								
18	323-600-05150	CLIP	1	1	1	1	1								
19	361-300-45090	CLIP	1	1	1	1	1								
20	323-600-05170	CLAMP	1	1	1	1	1								
21	323-600-05180	BASE, TERMINAL	1	1	1	1	1								
22	183-386-51020	TERMINAL	6	6	6	6	6								
23	183-386-51030	CAP	6	6	6	6	6								
24	361-300-45100	GUIDE, CORD	1	1	1	1	1								
25	313-700-05070	BUSH	1	1	1	1	1								
26	361-300-45110	PACKING	1	1	1	1	1								
27	361-300-45120	PACKING	1	1	1	1	1								
28	323-600-05220	PACKING	1	1	1	1	1								
29	361-300-45130	CONNECTOR	1	1	1	1	1								
30	361-300-45140	CONNECTOR	1	1	1	1	1								
31	333-700-25220	LOCK, CORD	1	1	1	1	1								
32	361-300-45160	PLATE, HOLDER	1	1	1	1	1								
33	801-651-05012	SCREW, MACHINE M5X12	4	4	4	4	4								
34	901-012-06012	BOLT M6X12	10	10	10	10	10								
35	901-012-06010	BOLT M6X10	4	4	4	4	4								
36	801-611-03006	SCREW, MACHINE M3X6	3	3	3	3	3								
37	801-611-04040	SCREW, MACHINE M4X40	4	4	4	4	4								

100

組立名称 ディテクタ, オーバ ワインディング
 Assembly Name DETECTOR, OVER WINDING

組立番号 a < 333-701-90000 > b < > c < >
 Assembly No. d < > e < > f < >
 g < > h < > i < > j < >

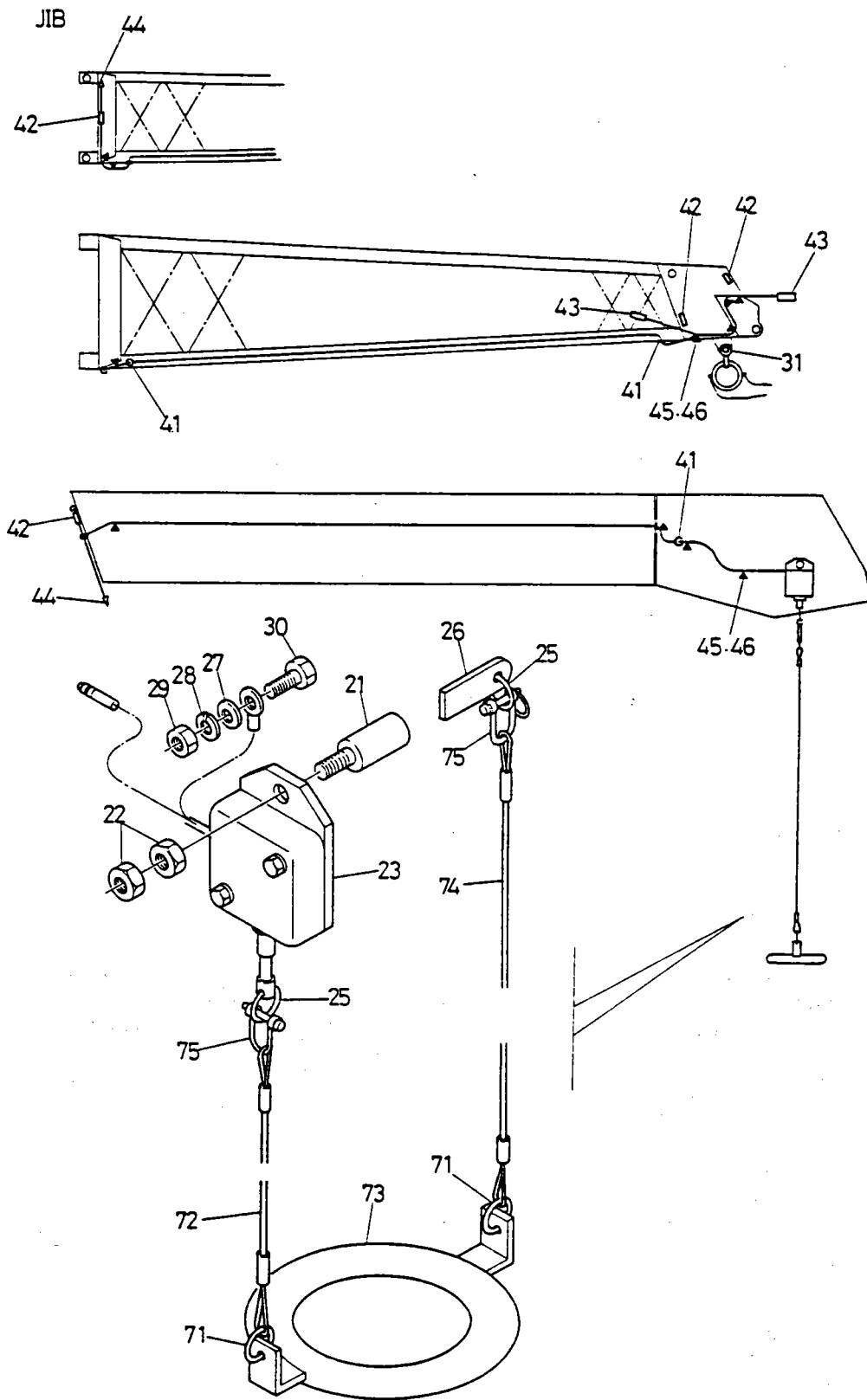

組立名称 ハイピッキングバント
 Assembly Name PIPING, VENT

組立番号 a < 333-405-90000 > b < 333-404-30000 > c < >
 Assembly No. d < > e < > f < >
 g < > h < > i < > j < >

指示番号 Key No.	部品番号 Part No.	部品名称 Part Name	Q'ty Per Section 個数											備考 Remarks			
			a	b	c	d	e	f	g	h	i	j	k				
1	370-007-00960	CLAMP ASSY	2	2													
2	804-001-60108	FITTING	1	1													
3	333-400-81050	HOSE 4.31X6.35	1	1													333-404-30010
4	814-080-00130	PIPE, STEEL 10	1	1													
5	910-021-01100	O, RING P11	3	3													
6	804-001-60127	JOINT	1	1													
7	804-001-60118	FITTING	1	1													
8	803-020-90101	FITTING KCD10PF1/4S	2	2													
9	814-080-00130	PIPE, STEEL 10	1	1													
10	803-020-10100	FITTING KCD10PT1/4S	2	2													
11	366-200-20000	VALVE, CHECK	1	1													SEE P1114-006
12	366-400-10000	VALVE, SOLENOID	1	1													SEE P1112-004
13	901-022-05012	BOLT M5X12	2	2													
14	903-020-40501	WASHER, SPRING 5	2	2													

110

組立名称 シリンダ、ブレーキ
 Assembly Name CYLINDER, BRAKE

組立番号 a < 360-601-00000 > b < > c < >
 Assembly No. d < > e < > f < >
 g < > h < > i < > j < >

指示番号 Key No.	部品番号 Part No.	部品名称 Part Name	Q'ty Per Section 個数											備考 Remarks
			a	b	c	d	e	f	g	h	i	j		
1	910-011-05500	O,RING 1A P55	1											
2	914-112-05500	RING,BACKUP	1											
3	916-840-06500	PACKING SGY65	1											
4	360-601-01000	CYLINDER	1											
5	360-601-02000	PISTON	1											
6	360-601-03000	BOOT	1											
7	594-571-38000	PLUG	1											
10	360-601-00000	CYLINDER ASSY BRAKE	1											

115

組立名称 ハルワ、カウンタランス
 Assembly Name VALVE,COUNTERBALANCE

組立番号 a < 366-000-20000 > b < 366-000-30000 > c < 366-001-00000 >
 Assembly No. d < 366-001-70000 > e < > f < >
 g < > h < > i < > j < >

指示番号 Key No.	部品番号 Part No.	部品名称 Part Name	Q'ty Per Section 個数											備考 Remarks			
			a	b	c	d	e	f	g	h	i	j					
1	366-000-20000	VALVE ASSY COUNTERBALANCE	1	-	-	-											
1	366-000-30000	VALVE ASSY COUNTERBALANCE	-	1	-	-											
1	366-001-00000	VALVE ASSY COUNTERBALANCE	-	-	1	-											
1	366-001-70000	VALVE ASSY COUNTERBALANCE	-	-	-	1											
2	366-000-25010	COVER	1	-	1	-											
5	162-651-03050	SPRING	1	-	1	-											
6	162-651-03060	SPRING	1	-	1	-											
7	366-000-25040	GUIDE,SPRING	1	-	1	-											
8	162-651-03080	NUT,LOCK	1	1	1	1											
9	162-651-03091	NUT,CAP	1	1	1	1											
10	366-000-35040	STOPPER	-	1	-	-											
10	366-001-75030	STOPPER	-	-	-	1											
11	366-000-25060	SPRING	1	1	1	1											
12	366-000-25070	SPRING	1	1	1	1											
13	366-001-05060	NUT	-	-	1	-											
16	907-300-12450	SCREW M12X45	1	1	1	1											
17	901-315-12045	BOLT,HEXAGON SOCKET M12X45	4	-	4	-											
18	803-160-30100	PLUG 3/4	1	1	-	-											
19	803-160-30040	PLUG 1/4	2	2	3	2											
20	803-160-30020	PLUG 1/8	2	2	2	2											
21	162-151-01190	PLUG 1/16	1	1	1	1											
22	914-110-03900	RING,BACKUP P39	1	1	-	-											
22	914-110-03600	RING,BACKUP P36	-	-	1	1											
23	914-110-01800	RING,BACKUP P18	1	1	1	1											
24	910-022-06000	O,RING G60	1	1	1	1											
25	910-011-03900	O,RING P39	1	1	-	-											
25	910-011-03600	O,RING P36	-	-	1	1											
26	910-022-03500	O,RING G35	3	3	3	3											
27	910-022-03000	O,RING G30	-	-	1	-											
28	910-011-01800	O,RING P18	1	1	1	1											
29	910-021-01600	O,RING P16	2	2	2	2											
30	805-600-58000	BALL,STEEL 9/32	1	1	1	1											
33	366-001-10000	VALVE ASSY,RELIEF	1	1	1	1											
36	366-001-05080	SPACER	-	-	1	-											
37	366-001-05090	SPACER	-	-	1	-											
54	366-001-15040	BOLT,ADJUSTING	1	1	1	1											

組立名称 ハルマ、パイロット チェック
 Assembly Name VALVE,PILOT CHECK

組立番号 a < 366-202-60000 > b < > c < >
 Assembly No. d < > e < > f < >
 g < > h < > i < > j < >

指示番号 Key No.	部品番号 Part No.	部品名称 Part Name	Q'ty Per Section 個数											備考 Remarks	
			a	b	c	d	e	f	g	h	i	j	k		
1	366-202-60000	VALVE ASSY PILOT CHECK	1												
4	914-110-01600	RING BACKUP	2												
5	910-011-01600	O,RING 1A P16	1												
6	122-151-20000	SPRING	1												
9	516-550-04000	PISTON	1												
10	910-021-02400	O,RING 1B P24	2												
11	366-200-00030	PLUG	2												
12	910-021-01000	O,RING 1B P10	2												
20	901-015-10055	BOLT M10X55	4												
21	903-020-41001	WASHER,SPRING 10	4												

組立名称 Assembly Name		CAB, OPERATOR											備考				
組立番号 Assembly No.		a < 332-600-00000 > d < > g < >			b < 332-600-20000 > e < > i < >			c < 332-600-40000 > f < > j < >					備考				
指示番号 Key No.	部品番号 Part No.	部品名称 Part Name	Q'ty Per Section 個数											備考 Remarks			
			a	b	c	d	e	f	g	h	i	j	k				
1	909-270-50121	SCREW, TAPPING M5X12	5	5	5												
2	903-052-00501	WASHER 5	5	5	5												
3	332-600-00500	GUIDE	1	1	1												
4	332-600-00010	COVER	1	1	1												
5	332-600-00020	COVER	1	1	1												
6	902-610-01000	U, NUT M10	2	2	2												
7	332-600-00030	CUSHION	2	2	2												
8	901-015-08015	BOLT M8X15	2	2	2												
9	903-020-40801	WASHER, SPRING 8	7	7	7												
10	332-600-00040	SHIM T1.0	2	2	2												
11	332-600-00050	SHIM T1.6	2	2	2												
12	332-600-00060	SHIM T3.2	2	2	2												
13	332-600-00070	SHIM T4.5	2	2	2												
14	901-015-12030	BOLT M12X30	7	7	7												
15	903-020-41201	WASHER, SPRING 12	7	7	7												
16	332-600-00060	WASHER	7	7	7												
17	901-325-08040	BOLT, HEXAGON SOCKET M8X40	5	5	5												
18	903-030-71001	WASHER, PLAIN 10	5	5	5												
20	903-030-70801	WASHER, PLAIN 8	5	5	5												
21	332-600-10000	CAB ASSY	1	-	-												
21	332-600-30000	CAB ASSY	-	1	-												
21	332-600-50000	CAB ASSY	-	-	1												
23	370-005-04360	PLATE	5	5	5												
24	370-005-04370	PLATE	5	5	5												
25	370-005-04380	PLATE	5	5	5												
32	332-600-15320	DOOR ASSY	1	1	1												
34	332-600-10040	WIPER ASSY	1	1	1												
35	332-600-10050	WIPER ASSY	1	1	1												
36	332-600-10060	SASH ASSY	1	1	1												
37	332-600-10070	SASH ASSY	1	1	1												
38	332-600-10080	GLASS	1	1	1												
39	332-600-10090	GLASS	1	1	1												
40	332-600-10100	GLASS	1	1	1												
41	332-600-10110	GLASS	1	1	1												

25

組立名称 300M REST, INSTALATION
 Assembly Name 300M REST, INSTALLATION

組立番号 a < 337-602-40000 > b < 337-603-30000 > c < 337-608-60000 >
 Assembly No. d < 337-614-30000 > e < 337-613-10000 > f < 337-615-70000 >
 g < 337-618-10000 > h < 337-616-00000 > i < 337-616-10000 > j < >

指示番号 Key No.	部品番号 Part No.	部品名称 Part Name	Q'ty Per Section 個数											備考 Remarks	
			a	b	c	d	e	f	g	h	i	j			
1	337-613-11000	SUPPORT, 300M	-	-	-	1	1	-	-	-	-	-	-	-	
1	337-618-11000	SUPPORT, 300M	-	1	1	-	-	1	1	-	-	-	-	-	
1	337-616-01001	SUPPORT, 300M	-	-	-	1	1	-	-	-	1	1	-	-	
3	562-603-04000	SUPPORT	2	-	-	-	-	-	-	-	-	-	-	-	
3	563-608-11000	SUPPORT	-	2	2	2	2	2	2	2	2	2	2	2	
4	901-012-12025	BOLT M8X25	8	8	8	8	8	8	8	8	8	8	8	8	
5	903-020-41201	WASHER, SPRING 12	8	8	8	8	8	8	8	8	8	8	8	8	

159

組立名称 ステップ・インストール
 Assembly Name STEP INSTALLATION

組立番号 a < 337-601-50000 > b < 337-604-60000 > c < 337-606-06000 >
 Assembly No. d < 337-603-10000 > e < > f < >
 g < > h < > i < > j < >

指示番号 Key No.	部品番号 Part No.	部品名称 Part Name	Qty Per Section 個数											備考 Remarks	
			a	b	c	d	e	f	g	h	i	j			
1	337-601-50010	STEP	1	1	1	1									
2	337-601-50060	BOLT	1	1	1	1									
3	903-020-41201	WASHER, SPRING 12	1	1	1	1									
4	337-601-50080	SUPPORT	1	1	1	1									
5	337-601-50090	SUPPORT	1	1	1	-									
5	337-603-10010	SUPPORT	-	-	-	1									
6	337-601-50100	STOPPER	1	1	1	-									
7	337-601-50110	SUPPORT	1	1	-	-									
7	337-603-10030	SUPPORT	-	-	-	1									
10	337-601-58010	SUPPORT ASSY, STEP	1	1	1	-									
10	337-603-18010	SUPPORT ASSY, STEP	-	-	-	1									
11	337-603-10020	STOPPER	-	-	-	1									

165

CLICK HERE TO **DOWNLOAD** THE COMPLETE MANUAL

- Thank you very much for reading the preview of the manual.
- You can download the complete manual from: www.heydownloads.com by clicking the link below



- Please note: If there is no response to CLICKING the link, please download this PDF first and then click on it.

CLICK HERE TO **DOWNLOAD** THE COMPLETE MANUAL