



PARTS CATALOG

**HYDRAULIC CRANE
PARTS
CATALOG
MODEL TG-500ERG**

パーツカタログ
INFORMATION NO. TG-500ERG-1/P-01
APPLICABLE SERIAL NO. 435653~



TG-500ERG-1/P-01

01

TADANO LTD.

CLICK HERE TO **DOWNLOAD** THE COMPLETE MANUAL

- Thank you very much for reading the preview of the manual.
- You can download the complete manual from: www.heydownloads.com by clicking the link below



- Please note: If there is no response to CLICKING the link, please download this PDF first and then click on it.

CLICK HERE TO **DOWNLOAD** THE COMPLETE MANUAL

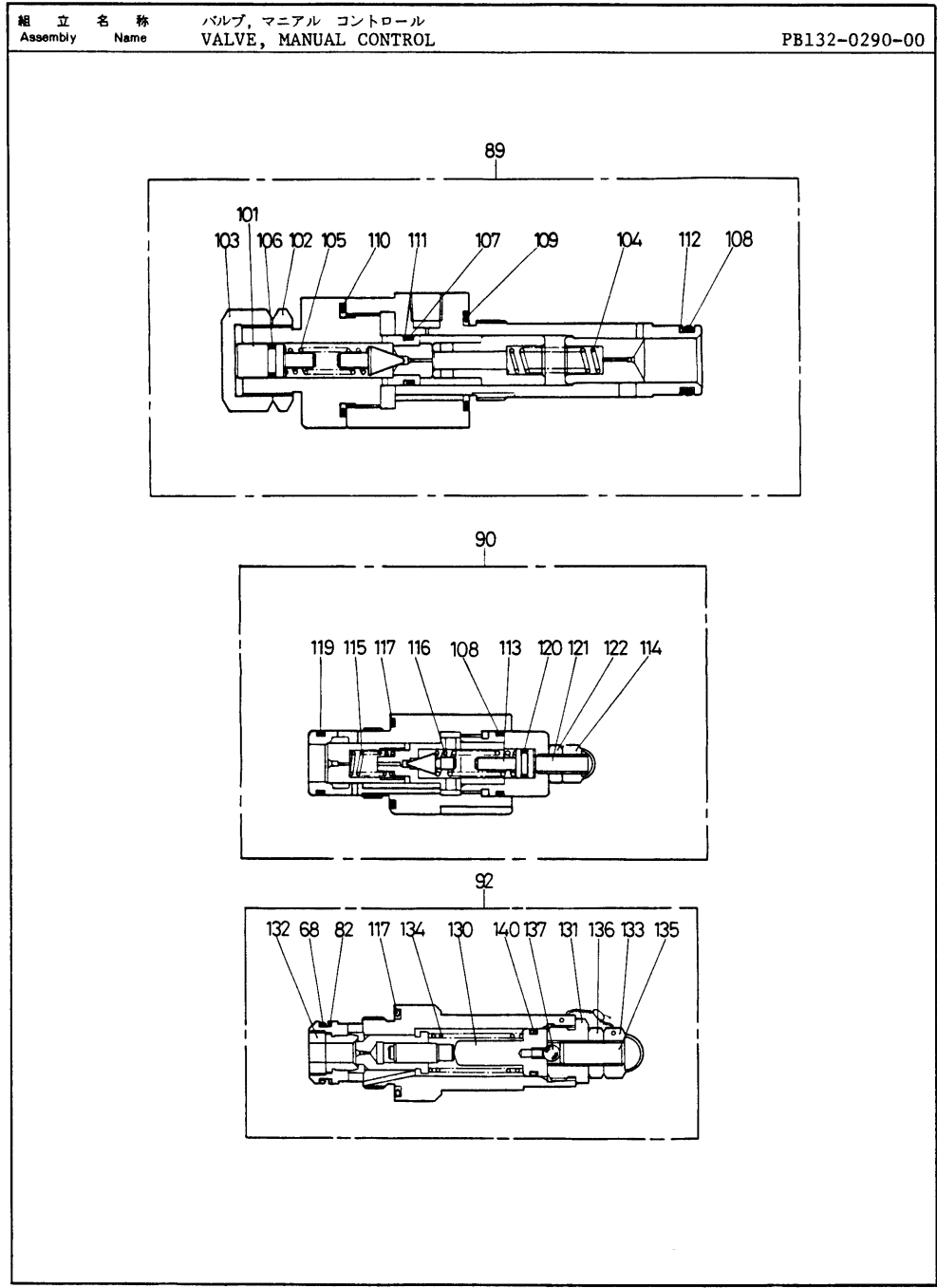
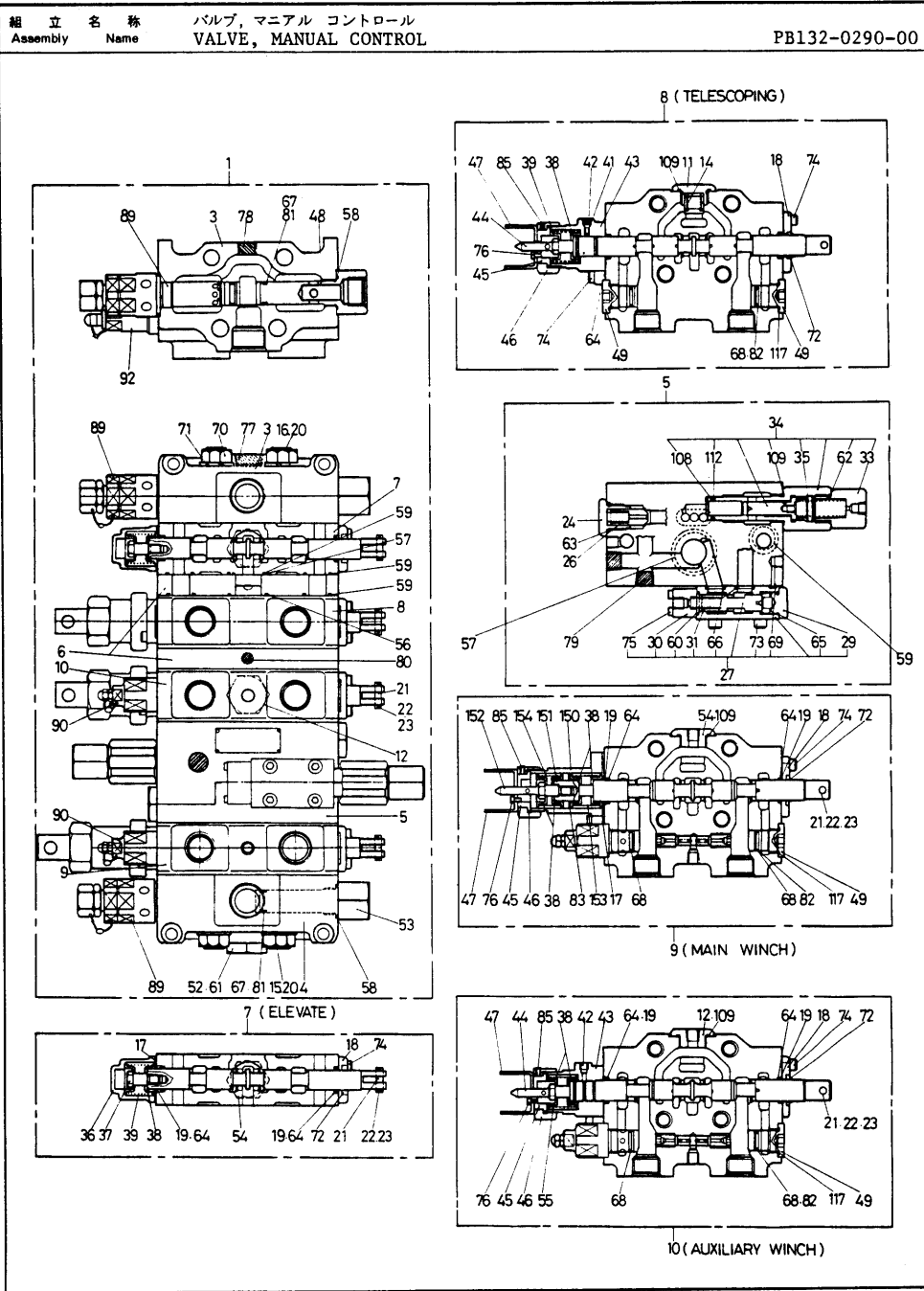

15

| | | |
|-----------------------|------------------------|---------------|
| 組立名称 Assembly Name | ロープ, ワイヤ ROPE, WIRE | PF107-0005-00 |
|-----------------------|------------------------|---------------|

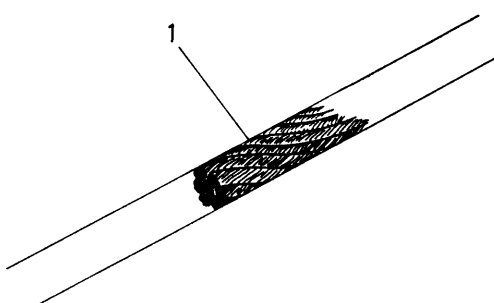

A technical drawing showing a perspective view of a rope or wire. The rope is shaded with cross-hatching to indicate its cylindrical form. A leader line with the number '1' points to the rope.

| | | |
|---------------------------|------------------------|--------------------|
| 組立名称 Assembly Name | ロープ, ワイヤ ROPE, WIRE | FIG. PF107-0005-00 |
| 仕様番号 Specification No. | A < TG-500E-1-90501 > | |

| 指示番号 Key No. | 部品番号 Part No. | 部品名称 Part Name | Qty Per Section 個数 | | | | | | | | | | | | | 実施号 Serial No. (変更番号 Modifi. No.) | ページ Page | | |
|-----------------|------------------|--------------------|--------------------|---|---|---|---|---|---|---|---|---|---|---|---|--|-------------|---|---|
| | | | A | B | C | D | E | F | G | H | I | J | K | L | M | | | N | O |
| 1 | 370-018-00560 | ROPE, WIRE 18X175H | 1 | | | | | | | | | | | | | | | | |
| | | | | | | | | | | | | | | | | | | | |
| | | | | | | | | | | | | | | | | | | | |
| | | | | | | | | | | | | | | | | | | | |
| | | | | | | | | | | | | | | | | | | | |
| | | | | | | | | | | | | | | | | | | | |
| | | | | | | | | | | | | | | | | | | | |
| | | | | | | | | | | | | | | | | | | | |
| | | | | | | | | | | | | | | | | | | | |
| | | | | | | | | | | | | | | | | | | | |

25

CLICK HERE TO **DOWNLOAD** THE COMPLETE MANUAL

- Thank you very much for reading the preview of the manual.
- You can download the complete manual from: www.heydownloads.com by clicking the link below



- Please note: If there is no response to CLICKING the link, please download this PDF first and then click on it.

CLICK HERE TO **DOWNLOAD** THE COMPLETE MANUAL

| 組立名称 Assembly Name | | ワイヤリングマテリアルズ WIRING MATERIALS | | FIG. PN140-0011-00 | | | | | | | | | | | | | | | | |
|-----------------------------|------------------|----------------------------------|---------------------|--------------------|---|---|---|---|---|---|---|---|---------------|---------------------------|-------------|---|---|---|---|---|
| スペック番号 Specification No. | | A < TG-500E-1-90501 > | | | | | | | | | | | | | | | | | | |
| 指示番号 Key No. | 部品番号 Part No. | 部品名称 Part Name | Q'ty Per Section 個数 | | | | | | | | | | 実施号 (変更番号) | Serial No. Modifi. No. | ページ Page | | | | | |
| | | | A | B | C | D | E | F | G | H | I | J | | | | K | L | M | N | O |
| 1 | 821-000-00193 | CONNECTOR | N | | | | | | | | | | | | | | | | | |
| 2 | 821-000-00224 | CONNECTOR | N | | | | | | | | | | | | | | | | | |
| 3 | 821-000-00225 | CONNECTOR | N | | | | | | | | | | | | | | | | | |
| 4 | 821-000-00226 | CONNECTOR | N | | | | | | | | | | | | | | | | | |
| 5 | 821-000-00227 | CONNECTOR | N | | | | | | | | | | | | | | | | | |
| 6 | 821-000-00228 | CONNECTOR | N | | | | | | | | | | | | | | | | | |
| 7 | 821-000-00229 | CONNECTOR | N | | | | | | | | | | | | | | | | | |
| 8 | 821-000-00268 | CONNECTOR ASSY | N | | | | | | | | | | | | | | | | | |
| 9 | 821-000-00269 | CONNECTOR ASSY | N | | | | | | | | | | | | | | | | | |
| 10 | 821-000-00270 | CONNECTOR ASSY | N | | | | | | | | | | | | | | | | | |
| 11 | 821-000-00271 | CONNECTOR ASSY | N | | | | | | | | | | | | | | | | | |
| 12 | 821-000-00272 | CONNECTOR ASSY | N | | | | | | | | | | | | | | | | | |
| 13 | 821-000-00273 | CONNECTOR | N | | | | | | | | | | | | | | | | | |
| 14 | 821-000-00274 | CONNECTOR ASSY | N | | | | | | | | | | | | | | | | | |
| 15 | 821-000-00275 | CONNECTOR ASSY | N | | | | | | | | | | | | | | | | | |
| 16 | 821-000-00276 | CONNECTOR ASSY | N | | | | | | | | | | | | | | | | | |
| 17 | 821-000-00277 | CONNECTOR ASSY | N | | | | | | | | | | | | | | | | | |
| 18 | 821-000-00278 | CONNECTOR | N | | | | | | | | | | | | | | | | | |
| 19 | 821-000-00279 | TERMINAL | N | | | | | | | | | | | | | | | | | |
| 20 | 821-000-00280 | CONNECTOR | N | | | | | | | | | | | | | | | | | |
| 21 | 821-000-00281 | CONNECTOR | N | | | | | | | | | | | | | | | | | |
| 22 | 821-000-00282 | CONNECTOR | N | | | | | | | | | | | | | | | | | |
| 23 | 821-000-00283 | CONNECTOR | N | | | | | | | | | | | | | | | | | |
| 24 | 821-000-00300 | CONNECTOR ASSY | N | | | | | | | | | | | | | | | | | |
| 25 | 821-000-00301 | CONNECTOR | N | | | | | | | | | | | | | | | | | |
| 26 | 821-000-00302 | CONNECTOR | N | | | | | | | | | | | | | | | | | |
| 27 | 821-000-00304 | CONNECTOR ASSY | N | | | | | | | | | | | | | | | | | |
| 28 | 821-000-00318 | CONNECTOR | N | | | | | | | | | | | | | | | | | |
| 29 | 821-000-00319 | CONNECTOR ASSY | N | | | | | | | | | | | | | | | | | |
| 30 | 821-000-00320 | CONNECTOR ASSY | N | | | | | | | | | | | | | | | | | |
| 31 | 821-000-00326 | CONNECTOR ASSY | N | | | | | | | | | | | | | | | | | |
| 32 | 821-000-00366 | CONNECTOR | N | | | | | | | | | | | | | | | | | |
| 33 | 821-000-00381 | CONNECTOR ASSY | N | | | | | | | | | | | | | | | | | |
| 34 | 821-000-00382 | CONNECTOR ASSY | N | | | | | | | | | | | | | | | | | |
| 35 | 821-000-00398 | CONNECTOR | N | | | | | | | | | | | | | | | | | |

| 組立名称 Assembly Name | | ワイヤリングマテリアルズ WIRING MATERIALS | | FIG. PN140-0011-00 | | | | | | | | | | | | | | | | |
|-----------------------------|------------------|----------------------------------|---------------------|--------------------|---|---|---|---|---|---|---|---|---------------|---------------------------|-------------|---|---|---|---|---|
| スペック番号 Specification No. | | A < TG-500E-1-90501 > | | | | | | | | | | | | | | | | | | |
| 指示番号 Key No. | 部品番号 Part No. | 部品名称 Part Name | Q'ty Per Section 個数 | | | | | | | | | | 実施号 (変更番号) | Serial No. Modifi. No. | ページ Page | | | | | |
| | | | A | B | C | D | E | F | G | H | I | J | | | | K | L | M | N | O |
| 36 | 821-000-00455 | CONNECTOR | N | | | | | | | | | | | | | | | | | |
| 37 | 821-000-00529 | HOUSING,CONNECTOR | N | | | | | | | | | | | | | | | | | |
| 38 | 821-000-00530 | HOUSING,CONNECTOR | N | | | | | | | | | | | | | | | | | |
| 39 | 821-000-00578 | TERMINAL | N | | | | | | | | | | | | | | | | | |
| 40 | 821-000-00579 | TERMINAL | N | | | | | | | | | | | | | | | | | |
| 41 | 821-000-00580 | TERMINAL | N | | | | | | | | | | | | | | | | | |
| 42 | 821-000-00581 | TERMINAL | N | | | | | | | | | | | | | | | | | |
| 43 | 821-000-00584 | CONNECTOR | N | | | | | | | | | | | | | | | | | |
| 44 | 821-000-00585 | CONNECTOR | N | | | | | | | | | | | | | | | | | |
| 45 | 821-000-00586 | CONNECTOR | N | | | | | | | | | | | | | | | | | |
| 46 | 821-000-00587 | CONNECTOR | N | | | | | | | | | | | | | | | | | |
| 47 | 821-000-00588 | CONNECTOR | N | | | | | | | | | | | | | | | | | |
| 48 | 821-000-00589 | CONNECTOR | N | | | | | | | | | | | | | | | | | |
| 49 | 821-000-00590 | CONNECTOR ASSY | N | | | | | | | | | | | | | | | | | |
| 50 | 821-000-00652 | HOUSING,CONNECTOR | N | | | | | | | | | | | | | | | | | |
| 51 | 821-000-00654 | CONNECTOR | N | | | | | | | | | | | | | | | | | |
| 52 | 821-000-00655 | CONNECTOR ASSY | N | | | | | | | | | | | | | | | | | |
| 53 | 821-000-00657 | CONNECTOR | N | | | | | | | | | | | | | | | | | |
| 54 | 821-000-00658 | CONNECTOR | N | | | | | | | | | | | | | | | | | |
| 55 | 821-000-00714 | CONNECTOR | N | | | | | | | | | | | | | | | | | |
| 56 | 821-000-00715 | HOUSING,CONNECTOR | N | | | | | | | | | | | | | | | | | |
| 57 | 821-000-00720 | CONNECTOR ASSY | N | | | | | | | | | | | | | | | | | |
| 58 | 821-000-00721 | SLEEVE | N | | | | | | | | | | | | | | | | | |
| 59 | 821-000-00820 | CONNECTOR ASSY | N | | | | | | | | | | | | | | | | | |
| 60 | 821-000-00821 | CONNECTOR ASSY | N | | | | | | | | | | | | | | | | | |
| 61 | 821-000-00822 | CONNECTOR ASSY | N | | | | | | | | | | | | | | | | | |
| 62 | 821-000-00823 | CONNECTOR ASSY | N | | | | | | | | | | | | | | | | | |
| 63 | 821-000-00824 | CONNECTOR ASSY | N | | | | | | | | | | | | | | | | | |
| 64 | 821-000-00825 | CONNECTOR ASSY | N | | | | | | | | | | | | | | | | | |
| 65 | 821-000-00826 | CONNECTOR ASSY | N | | | | | | | | | | | | | | | | | |
| 66 | 821-000-00834 | CONNECTOR ASSY | N | | | | | | | | | | | | | | | | | |
| 67 | 821-000-00959 | CONNECTOR | N | | | | | | | | | | | | | | | | | |
| 68 | 821-000-00960 | CONNECTOR | N | | | | | | | | | | | | | | | | | |
| 69 | 821-000-00961 | CONNECTOR | N | | | | | | | | | | | | | | | | | |
| 70 | 821-000-00962 | CONNECTOR | N | | | | | | | | | | | | | | | | | |

60

CLICK HERE TO **DOWNLOAD** THE COMPLETE MANUAL

- Thank you very much for reading the preview of the manual.
- You can download the complete manual from: www.heydownloads.com by clicking the link below



- Please note: If there is no response to CLICKING the link, please download this PDF first and then click on it.

CLICK HERE TO **DOWNLOAD** THE COMPLETE MANUAL