

AT-146-2A 42095900046 UPPER

**PB3000198-00 POWER UNIT
PD2000078-00 SWING UNIT
PF1000664-00 WINCH SYSTEM
PG2000086-01 BOOM UNIT
PH1000463-01 SAFETY DEVICES (MOTION CONTROLLER)
PJ3000272-00 BUCKET SYSTEM
PJ5000003-00 BOOSTER UNIT
PK2000898-00 FRAME UNIT
PO1000127-01 INDICATION PLATES
PW1000109-01 ACCESSORIES & TOOLS
PX1001084-00 MOUNTING PARTS
PY1000992-03 OPTIONS,1
PY2000059-06 OPTIONS,2
ASSEMBLY**

CLICK HERE TO **DOWNLOAD** THE COMPLETE MANUAL

- Thank you very much for reading the preview of the manual.
- You can download the complete manual from: www.heydownloads.com by clicking the link below



- Please note: If there is no response to CLICKING the link, please download this PDF first and then click on it.

CLICK HERE TO **DOWNLOAD** THE COMPLETE MANUAL

AT-146-2A 42095900046 UPPER

Pos No.	Parts No	Parts Name	Qty	Unit	Technical Data	Serial No (Start)	Serial No (End)	Remarks
1	36191070001	MOTION CONTROLLER (AMC)	1					

AT-146-2A 42095900046 UPPER

Pos No.	Parts No	Parts Name	Qty	Unit	Technical Data	Serial No (Start)	Serial No (End)	Remarks	Pages
1	(*****)	ACCESSORIES	1						000177

AT-146-2A 42095900046 UPPER

PH5031073-00 HARNESS
PH5031078-00 HARNESS
PH5031372-00 HARNESS (FOR DETECTOR,O/R LENGTH)
PH5031797-00 HARNESS
PH5032296-00 HARNESS
PH5032326-00 HARNESS
PH5032327-00 HARNESS
PH5032328-00 HARNESS
PH5032499-00 HARNESS
PH5032807-00 HARNESS
PH5034371-00 HARNESS
PH5034444-00 HARNESS
PI1010074-00 MOTOR,HYDRAULIC (SWING)
PI1010158-00 MOTOR,HYDRAULIC
PI1010177-00 MOTOR,HYDRAULIC
PI1100061-00 VALVE,RELIEF
PI1100135-00 VALVE,RELIEF
PI1120199-02 VALVE,SOLENOID
PI1120201-02 VALVE,SOLENOID
PI1120238-02 VALVE,SOLENOID
PI1140133-01 VALVE,CHECK
PI1140136-01 VALVE,CHECK
PI1140212-00 VALVE,CHECK
PI1140213-00 VALVE,CHECK
PI1140227-00 VALVE,CHECK
PI1240030-00 VALVE
PI1250141-00 VALVE,COUNTERBALANCE
PI1250153-00 VALVE,COUNTERBALANCE
PI1280041-01 VALVE,PILOT CHECK
PI1300031-00 FILTER,OIL
PI1300041-00 FILTER,OIL
PJ3010104-00 BUCKET
PJ3010107-00 BUCKET (INNER CASE)
PJ3020033-03 FRAME
PJ3040024-00 OPE.ASSY
PJ3110024-01 PIPING (BUCKET)
PJ3240003-00 COVER (CLOTH,WHITE)
PJ3240023-00 COVER (FRP,WHITE)
PJ3250009-01 PIPING,GREASE (WINCH)
PJ3250012-01 PIPING,GREASE
PJ3340007-00 CYLINDER,LIFT
PK1011246-00 FRAME
PK1100374-03 SWING FRAME
PK1200397-02 COVER,SWING FRAME
PK1330180-00 COVER (BOOM)
PK1330216-02 COVER (MOTOR UNIT)
PL1020056-02 LEVER,CONTROL
PM5210017-00 MOTOR ASSY,OIL
PN1013283-05 ELEC.ASSY (SWING FRAME)
PN1013300-01 ELEC.ASSY (BUCKET)
PN1013474-01 ELEC.ASSY (BOOM)
PN1013475-02 ELEC.ASSY (CHARGER)
PN1013507-00 ELEC.ASSY (MOTOR UNIT)
PN1013513-00 ELEC.ASSY (FRAME)
PN1013528-01 ELEC.ASSY (POWER UNIT)
PN1013741-00 ELEC.ASSY
PN1014135-00 ELEC.ASSY (MOTOR UNIT)
PN1030056-00 OPTICAL CABLE
PN1080104-04 LAMP (AML)
PN1080105-00 LAMP
PN1080106-00 LAMP (BUCKET)
PN1080107-02 LAMP (SWING FRAME)
PN1080225-01 LAMP (LEFT,TOOL BOX)
PN1080302-00 LAMP (O/R CONTROL PANEL)

**AT-146-2A 42095900046 UPPER
PB1320319-00 VALVE,MANUAL CONTROL**

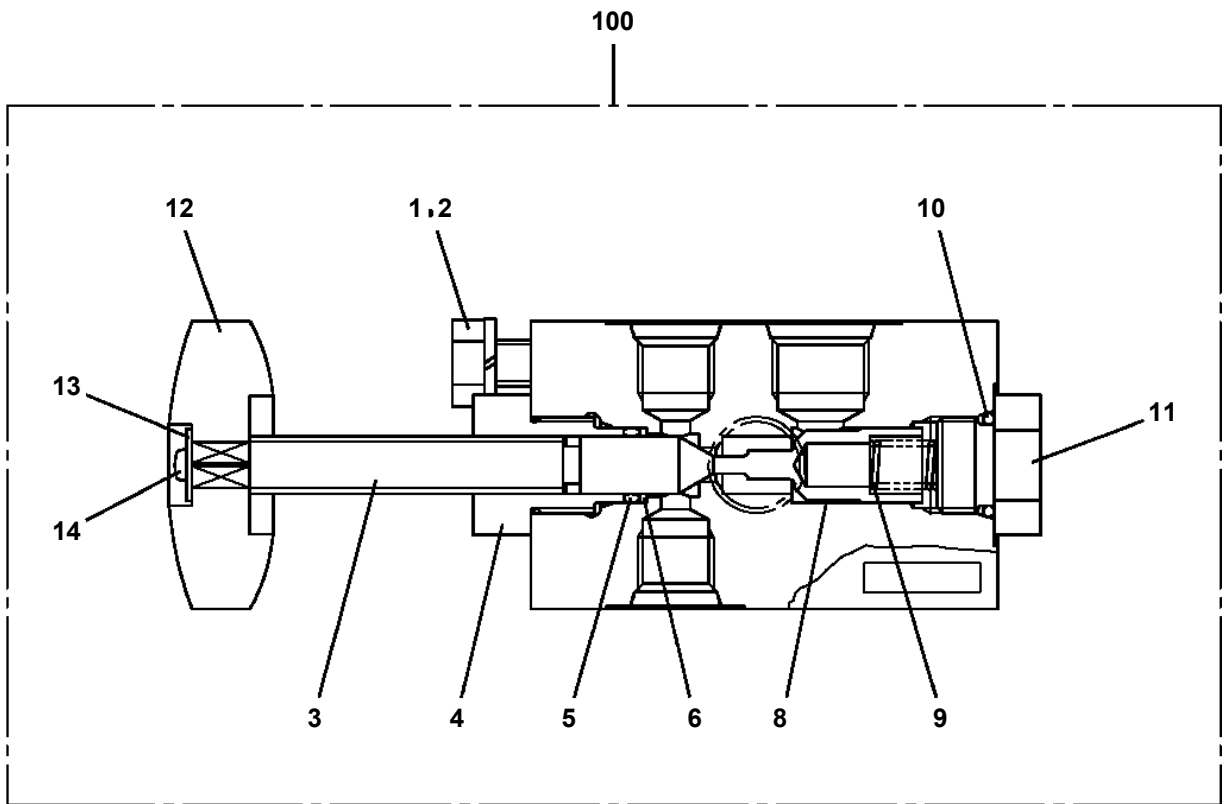

**AT-146-2A 42095900046 UPPER
PB1320572-01 VALVE,MANUAL CONTROL**

9

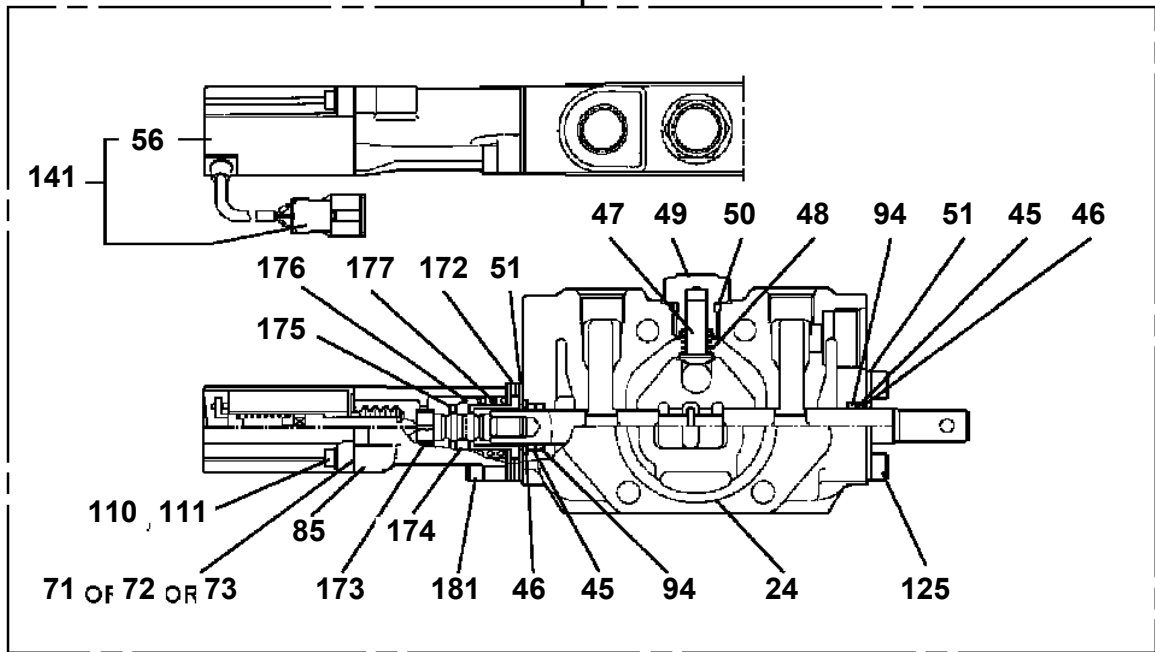

10

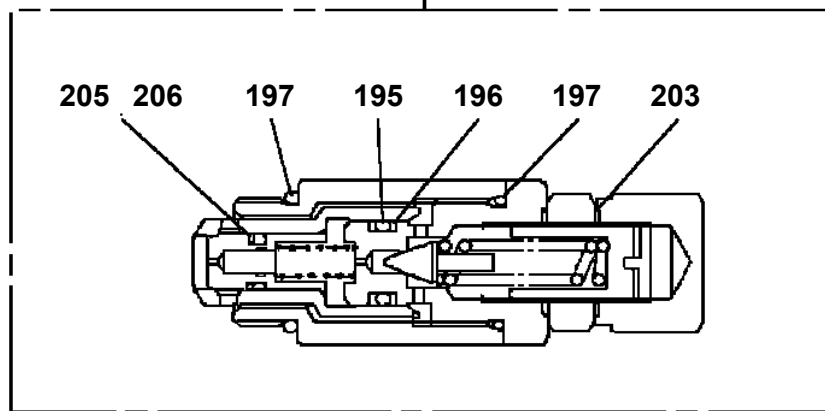

AT-146-2A 42095900046 UPPER

Pos No.	Parts No	Parts Name	Qty	Unit	Technical Data	Serial No (Start)	Serial No (End)	Remarks	Pages
1	36900330000	MOTOR,ELECTRIC	1						
2	42421653100	SUPPORT	1						
3	90101210020	BOLT	3		M10X20				
4	90302041001	WASHER,SPRING	3		10				
5	90303071001	WASHER,PLAIN	3		10				
6	42421653200	CUSHION	8						
7	42421694700	SUPPORT ASSY	1						
8	36654180000	PUMP,HYDRAULIC	1						00001
9	90103210035	BOLT	2		M10X35				
10	90171108020	BOLT	7		M8X20				
11	90302040801	WASHER,SPRING	7		8				
12	42421653300	SUPPORT	1						
31	42421653500	SUPPORT	1						
32	42421653600	CUSHION	1						
33	37000580520	PLATE	2						

AT-146-2A 42095900046 UPPER
PB1411723-00 PIPING,LOWER (TANK)

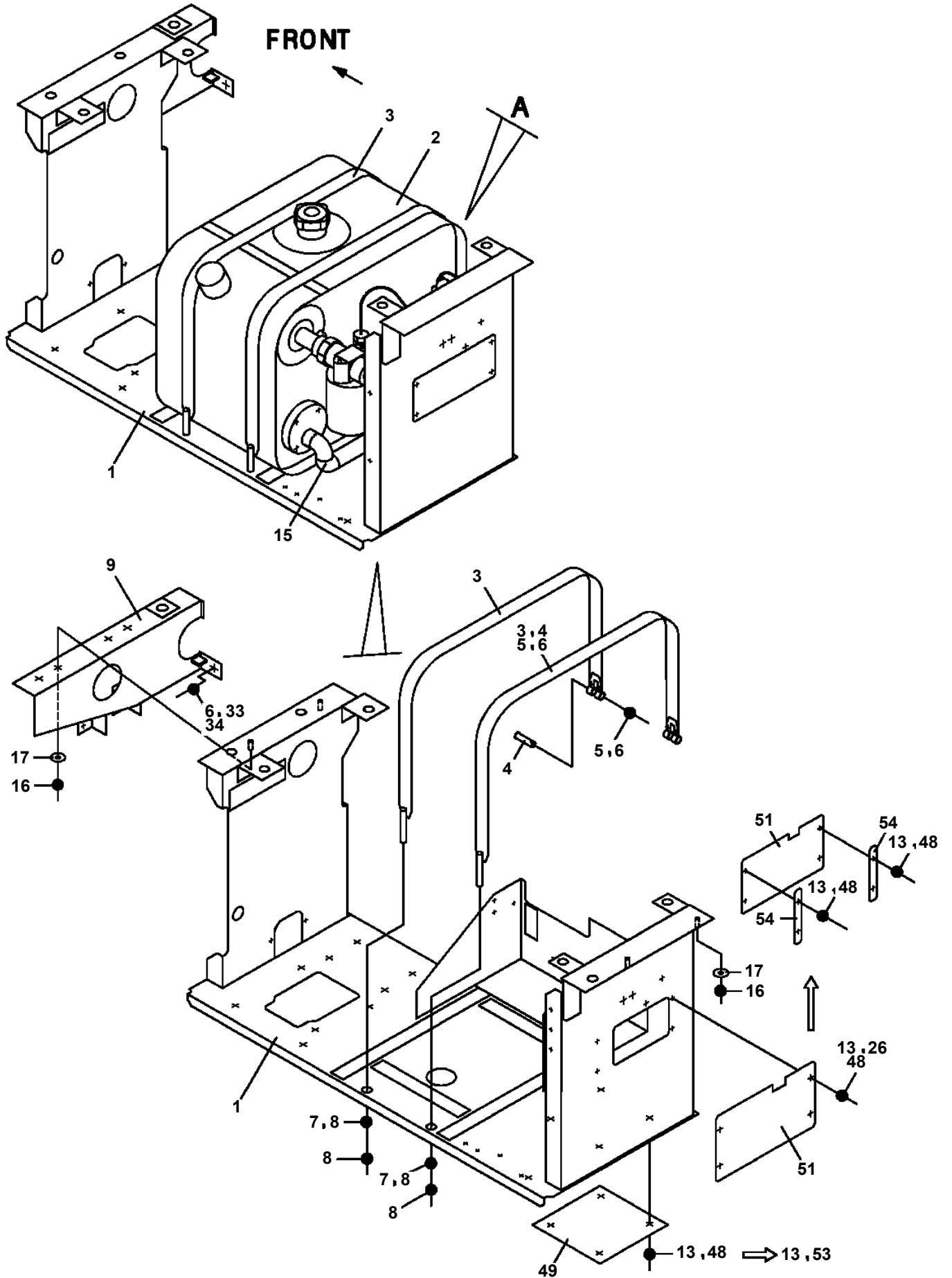

AT-146-2A 42095900046 UPPER
PC1011016-00 OUTRIGGER (REAR,REFCTOR)

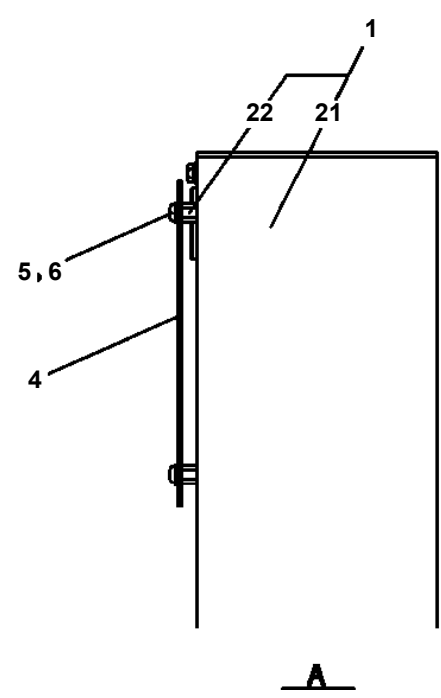
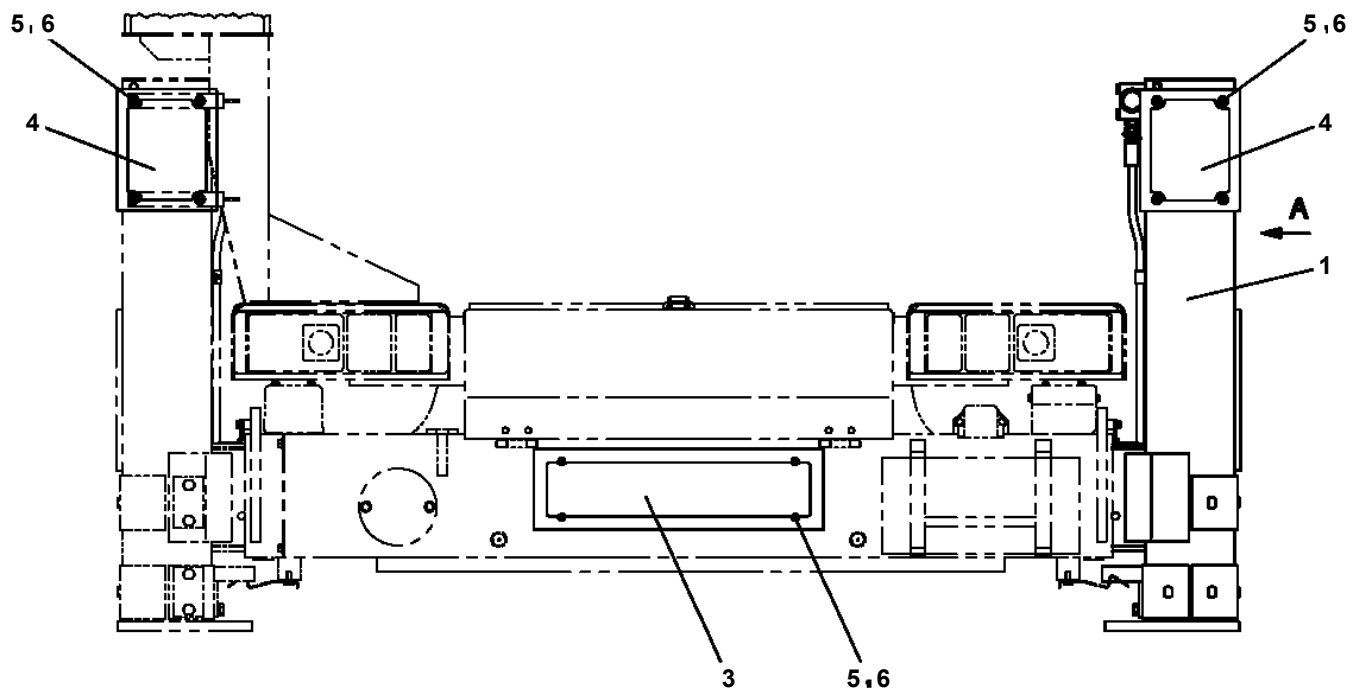

**AT-146-2A 42095900046 UPPER
PC1030346-00 CYLINDER,JACK**

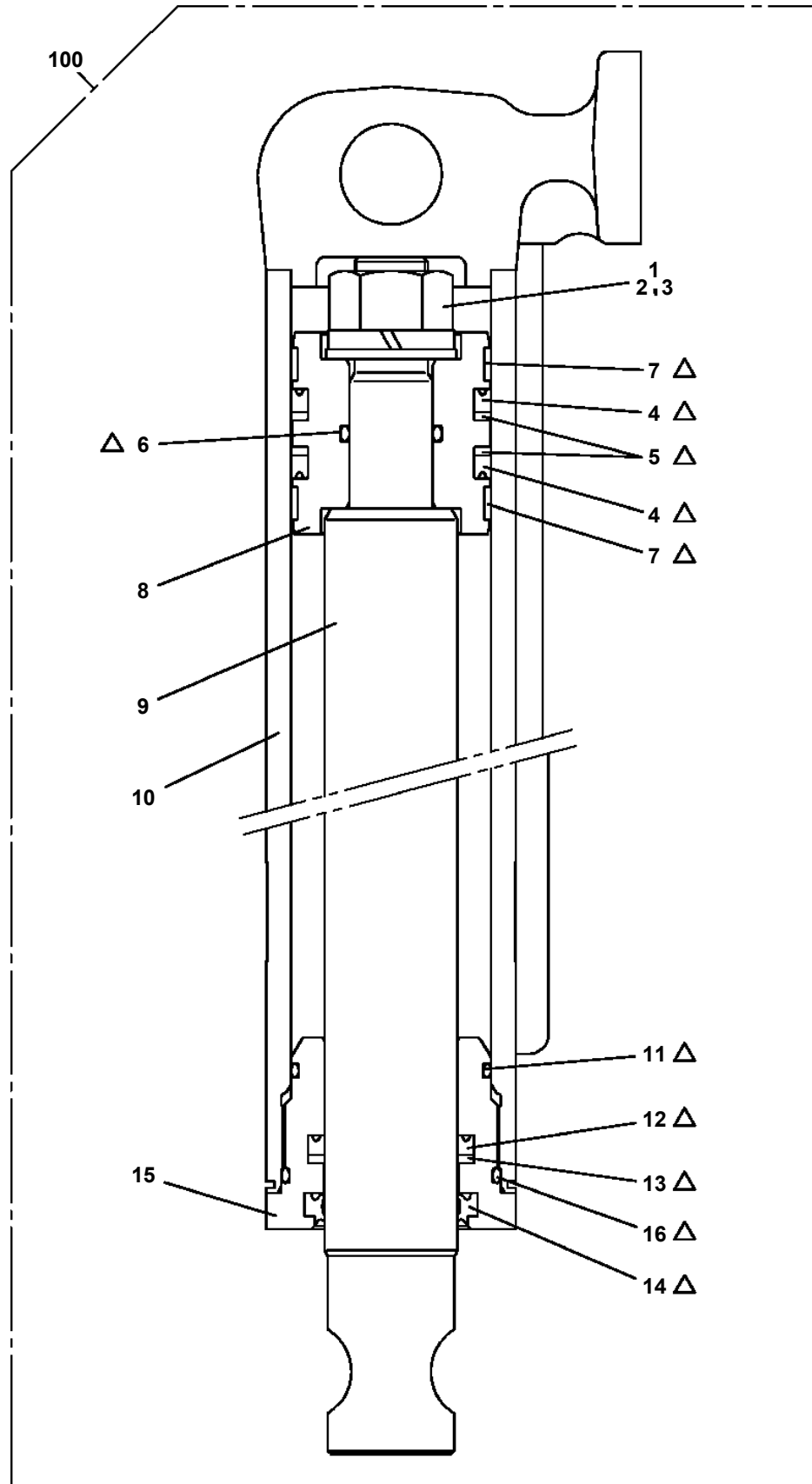

△:PACKING SET KEY NO.50 (KEY NO.4,5,6,7,11,12,13,14,16)

**AT-146-2A 42095900046 UPPER
PC1200516-02 PIPING,OUTRIGGER**

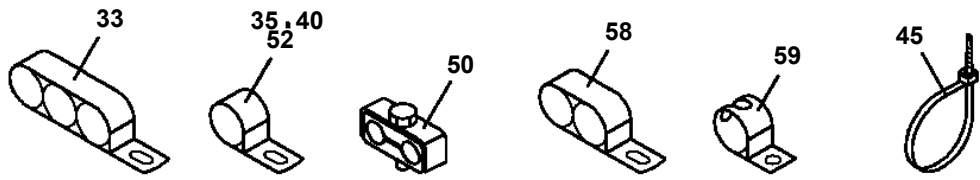
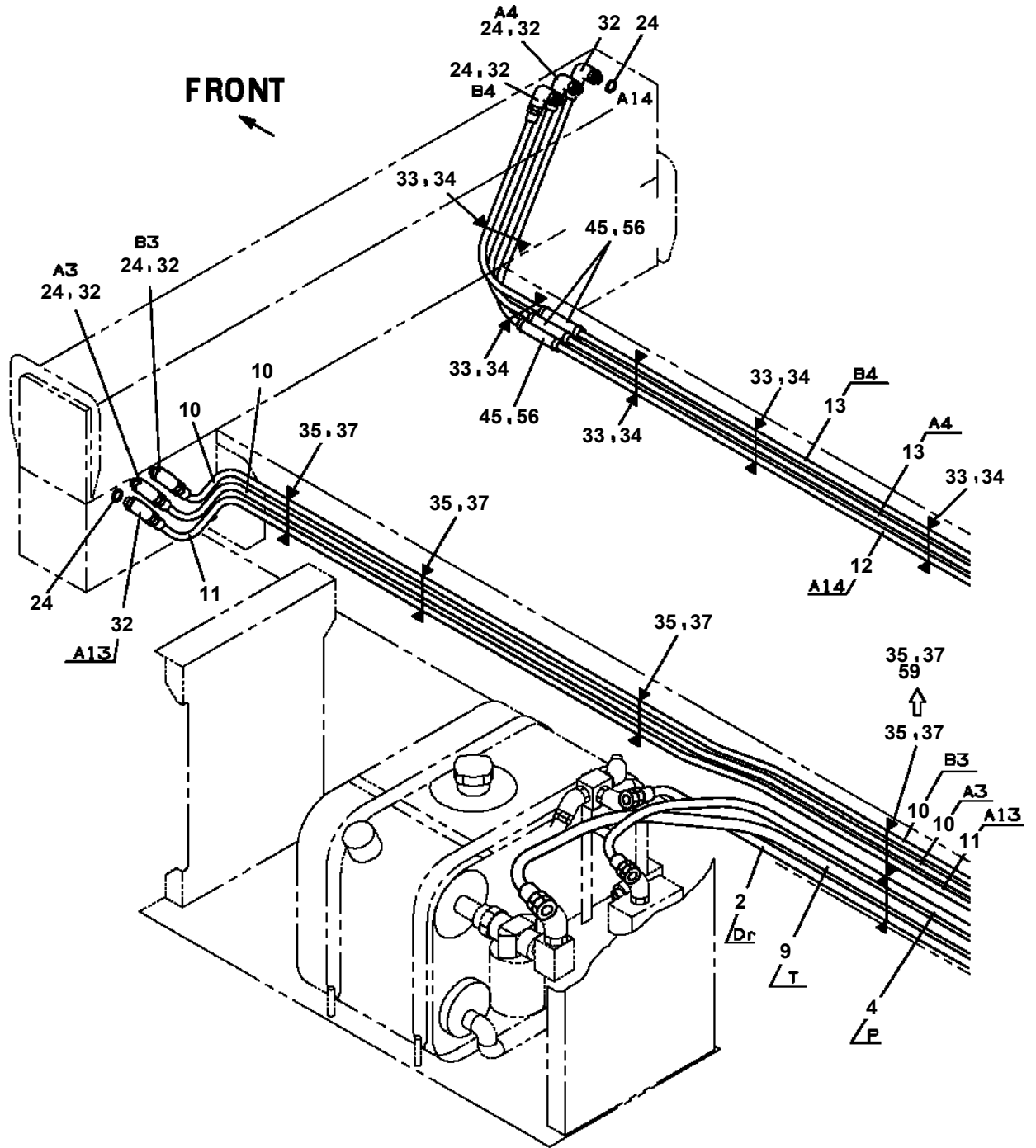

FRONT SIDE

AT-146-2A 42095900046 UPPER

Pos No.	Parts No	Parts Name	Qty	Unit	Technical Data	Serial No (Start)	Serial No (End)	Remarks	Pages
100	42652131301	CONTROLLER	1						

AT-146-2A 42095900046 UPPER

Pos No.	Parts No	Parts Name	Qty	Unit	Technical Data	Serial No (Start)	Serial No (End)	Remark
1	36026278010	CYLINDER,ELEVATING	1					
2	36605570000	VALVE,COUNTERBALANCE	1					
3	90171108125	BOLT	4		M8X125			
4	90302040801	WASHER,SPRING	4		8			
5	36625750000	VALVE,CHECK	1					
21	80801005025	BEARING,PLAIN	2					
22	82458102000	NIPPLE,GREASE	2		B-PT1/8			
23	82400000459	CAP	2					
24	80720105025	PIN,SPRING	1		5X25			
25	91302211500	BEARING,PLAIN	2					
26	91684011500	PACKING	2					
27	91411210001	RING,BACKUP	2					
28	91002804400	O-RING	1		1B P44			
29	36026081000	PISTON	1					
30	36026271000	ROD	1					
32	80612110860	RING,RITAINING	1		AR86			
33	91002810500	O-RING	1		1B P105			
34	37000400170	BEARING,PLAIN	1					
36	91001206500	O-RING	1		1A G65			
37	91694008000	PACKING	1					
38	91410208000	RING,BACKUP	1					
39	91002911500	O-RING	1		1B G115			
40	91660008000	SEAL,DUST	1					
41	80622000800	RING,RITAINING	1		SP80			
42	80720104020	PIN,SPRING	1		4X20			
43	80316030020	PLUG	2		PT1/8			
44	36023182000	END,ROD	1					
51	36026089510	CYLINDER ASSY	1					
52	36026089530	COVER,ROD	1					
53	36026089901	PACKING SET	1		80X115			
62	80541700050	BEARING,SPHERICAL	1					
64	82100000548	CONNECTOR	1					
67	82100001411	TUBE,SPIRAL	1	M	SE-08BK			
68	80316090020	PLUG	1		KKT PT1/8			
81	82100001155	CONNECTOR	1					

**AT-146-2A 42095900046 UPPER
PF1050285-00 HOOK (1-PART LINE WITH ROPE)**

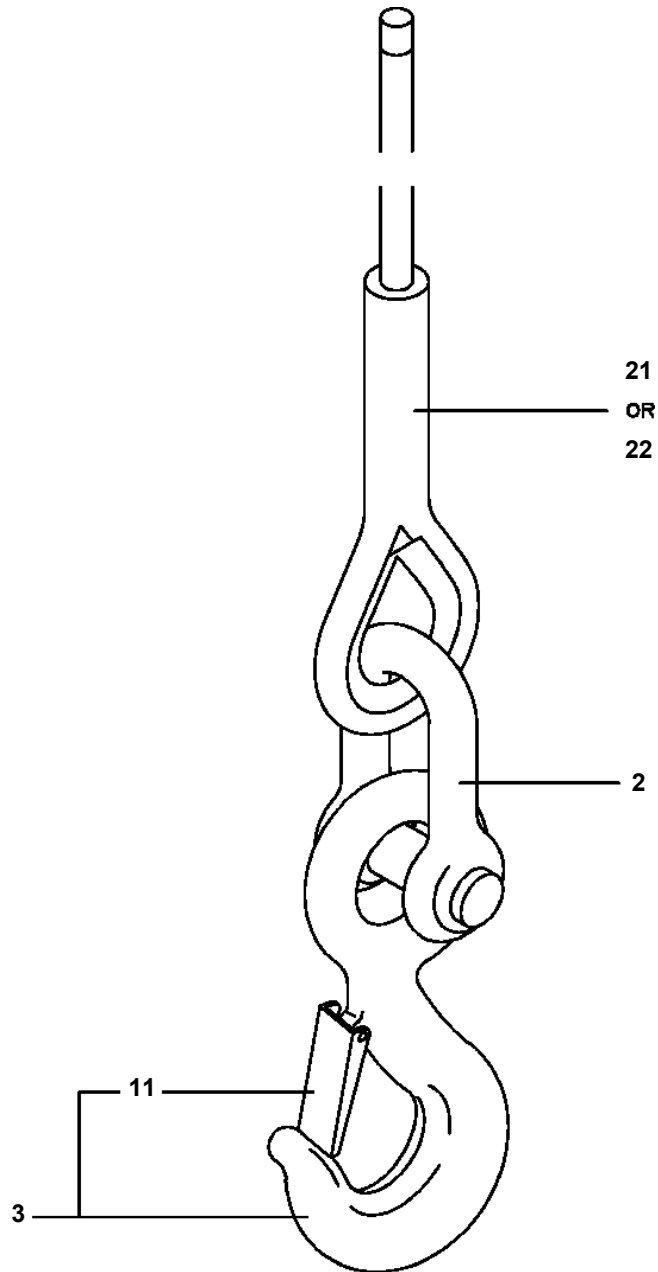

**AT-146-2A 42095900046 UPPER
PF1350084-02 WINCH, JIB (SUPPORT)**

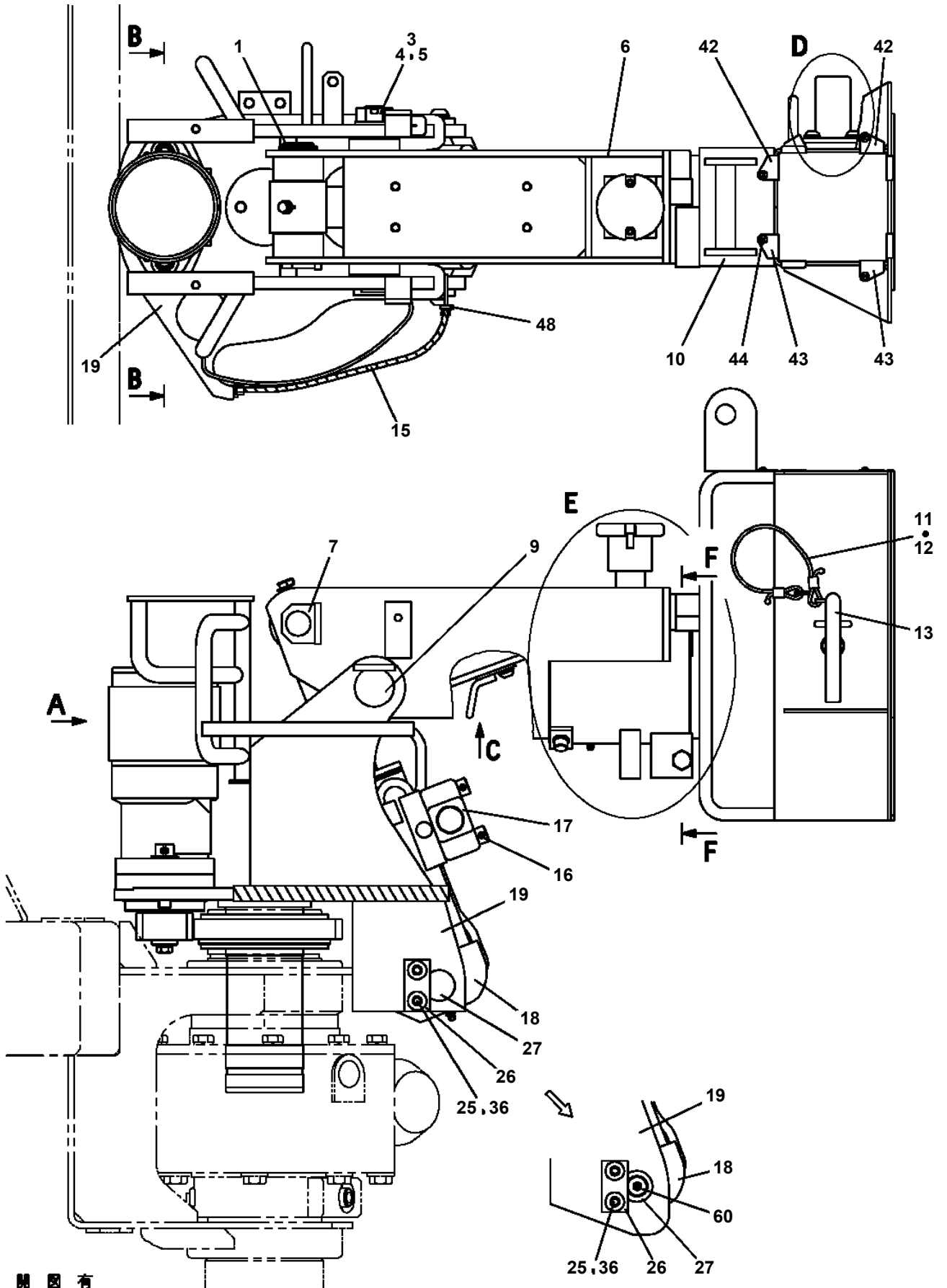

展開圖有
ILLUSTRATED BREAKDOWN NO. 6

AT-146-2A 42095900046 UPPER

Pos No.	Parts No	Parts Name	Qty	Unit	Technical Data	Serial No (Start)	Serial No (End)	Remarks	Pages
1	42220691001	SUPPORT	1						
2	42220692001	JIB	1				229146		
	42220692002	JIB	1			229147			
3	80601110350	RING,RITAINING	2		S35				
4	37000188130	PIN	1						
5	37001002260	SHEAVE	1						
6	90101216125	BOLT	1		M16X125				
7	90303071601	WASHER,PLAIN	2		16				
8	90302041601	WASHER,SPRING	1		16				
9	90240201600	NUT,CAP	1		M16				
10	37000314520	SPACER	2						
11	42220690100	PLATE	1		T=1.0				
12	42220690200	PLATE	1		T=2.0				
13	42220041050	PLATE,NAME	2						
31	80516006207	BEARING,BALL	1						

AT-146-2A 42095900046 UPPER

Pos No.	Parts No	Parts Name	Qty	Unit	Technical Data	Serial No (Start)	Serial No (End)	Re
64	37002014710	PLATE,SLIDE	2					
65	37000508520	PLATE	N		T=0.8			
66	80184306012	SCREW,MACHINE	6		M6X12			
67	37002006500	PLATE,SLIDE	2					
68	37002010340	PLATE,SLIDE	4					
69	90171110030	BOLT	16		M10X30			
70	37000176290	PIN	1					
71	37000312680	SPACER	2					
72	42201630400	SHEAVE ASSY	1					
73	80602110300	RING,RITAINING	2		R30			
74	31630482500	CAP	4					
75	37001007240	SHEAVE ASSY	2					
76	80602110400	RING,RITAINING	2		R40			
77	37000176300	PIN	2					
78	80601110400	RING,RITAINING	2		S40			
79	37000176310	PIN	1					
80	37000403580	BEARING,PLAIN (DAIDO METAL)	2					
81	42201630070	PLATE	2					
82	37000576030	PLATE	1					
83	37000574850	PLATE	2					
84	90171114040	BOLT	12		M14X40			
85	90309341401	WASHER,SPRING	28					
86	90171112030	BOLT	12		M12X30			
87	90302041201	WASHER,SPRING	12		12			
88	90202481200	NUT	4		M12			
90	37002014150	PLATE,SLIDE	2					
91	37002014160	PLATE,SLIDE	2					
92	90171114045	BOLT	16		M14X45			
93	37000574840	PLATE	8					
94	89631601000	HOSE,VINYL	1		15X20,1M			
95	91810130240	FASTENER	2					
96	90202481600	NUT	4		M16			
97	90174110030	BOLT	2		M10X30			
98	37000573180	PLATE	1					
99	37000144700	PIN	1					
100	90174110020	BOLT	2		M10X20			
101	37000524070	PLATE	1		T=6			
102	37000168250	PIN	1					
103	42202050020	ROLLER	2					
104	42200383280	PLATE	2					
105	90171110018	BOLT	4		M10X18			
106	90303071001	WASHER,PLAIN	8		10			
109	42202230300	SUPPORT	4					
161	42201700110	ROLLER ASSY	1					
162	37000184170	PIN	1					
163	90238402408	NUT,CASTLE	1		M24			
164	90303072401	WASHER,PLAIN	1		24			
165	80136350045	PIN,SPLIT	1		5X45			
171	42201700250	ROLLER ASSY	2					
172	42201700210	SUPPORT	1					
173	37000179830	PIN	2					
174	37000312280	SPACER	8					
182	42201700310	SUPPORT	1					
202	80513006012	BEARING,BALL	2					
203	80612110950	RING,RITAINING	2		AR95			
211	37002011650	PLATE,SLIDE	2					
212	42201460370	PLATE	N		T=0.8			
213	80184306016	SCREW,MACHINE	2		M6X16		228251	
	80184306020	SCREW,MACHINE	2		M16X20	228252		
214	42202050310	RETAINER	2					
222	80612110620	RING,RITAINING	2		AR62		228034	
	80602110620	RING,RITAINING	2		R62	228035		
223	80513006206	BEARING,BALL	4					

AT-146-2A 42095900046 UPPER

Pos No.	Parts No	Parts Name	Qty	Unit	Technical Data	Serial No (Start)	Serial No (End)
1	81408000130	PIPE,STEEL	4	M	10X1.8T		
2	81408000130	PIPE,STEEL	4	M	10X1.8T		
3	81408000241	PIPE,STEEL	4	M	18X1.9T		
4	81408000160	PIPE,STEEL	4	M	12X1.4T		
5	81408000210	PIPE,STEEL	4	M	15X2.0T		
6	80400160201	JOINT	2				
7	37002458200	HOSE	2		L=1850		
8	80320010090	FITTING	1		KUD15-030N		
9	80320010080	FITTING	1		KUD12-030N		
10	80320010140	FITTING	1		KUD18-040N		
11	37000578940	PLATE	4		T=3.0		
12	37002472240	HOSE	3		L=9940		
13	80400160127	JOINT	4				
14	91002801100	O-RING	4		1B P11		
15	37002478990	HOSE	2		L=9580		
16	80430620600	JOINT (WITH O-RING)	1		L,G3/8-G3/8		
17	42345161000	JOINT	1				
18	42343740100	COVER	1				
19	80192486014	SCREW,MACHINE (WITH WASHER)	4		M6X14		
20	90101210020	BOLT	10		M10X20		
21	90302041001	WASHER,SPRING	10		10		
22	42345162000	JOINT	1				
23	80320020080	FITTING	1		KUF12-030N		
24	80320020090	FITTING	1		KUF15-030N		
25	80320020050	FITTING	2		KUF10-020N		
26	37000919790	JOINT	2				
27	91002801400	O-RING	2		1B P14		
28	42344970500	CLAMP	3				
29	42345860100	SUPPORT	1				
30	90180208020	BOLT,BUTTON	2		M8X20		
31	90302040801	WASHER,SPRING	16		8		
32	90171108018	BOLT	4		M8X18		
33	42344970200	ROLLER ASSY	1				
34	42345860300	CLAMP	1				
35	37000556580	PLATE	2				
36	42345860500	CLAMP	1				
37	42344971000	SHEAVE ASSY (MARUCH)	1				
39	90101208045	BOLT	2		M8X45		
40	90101208012	BOLT	2		M8X12		
41	42344970800	SUPPORT	1				
42	37000714020	CLAMP ASSY	1		12X2		
43	37000573430	PLATE	6		T=1		
44	90203201200	NUT	4		M12		
45	90101208020	BOLT	6		M8X20		
46	37000312510	SPACER	2		L=27.5		
47	90303071201	WASHER,PLAIN	4		12		
48	90302041201	WASHER,SPRING	2		12		
49	37000564680	PLATE	1				
50	37000576570	PLATE	1				
51	90303070801	WASHER,PLAIN	2		8		
52	42345860200	SUPPORT	1				
54	37002418410	HOSE	1		L=9940		
75	80316070060	PLUG	2		PF3/8		
76	91002801400	O-RING	5		1B P14		
81	42344970210	SUPPORT	1				
82	37000174180	PIN	1				
83	42340234240	ROLLER	3		W=9		
84	44340392420	ROLLER	4				
85	90303100801	WASHER,PLAIN	14		8		
86	80136320016	PIN,SPLIT	2		2X16		
91	42344971100	SHEAVE (MARUCH)	1				
92	42344971110	PIN	1				
93	80136363050	PIN,SPLIT	2		6.3X50		

AT-146-2A 42095900046 UPPER

Pos No.	Parts No	Parts Name	Qty	Unit	Technical Data	Serial No (Start)	Serial No (End)	Remarks
1	44550527580	SWITCH,MICRO	1					
2	44550527570	COVER	1					
3	44350247560	SPRING (FOR PEDAL)	1					
4	82109901050	PEDAL	1					
5	82109905010	PACKING	1					
6	44350247580	PLATE (WITH SCREW)	1					
22	82116920408	CONNECTOR	1					
23	82122910100	CAP	1					
100	42476260000	FOOT SWITCH (OPTION)	1					

AT-146-2A 42095900046 UPPER

Pos No.	Parts No	Parts Name	Qty	Unit	Technical Data	Serial No (Start)	Serial No (End)	Remarks	Pages
100	42614053350	HARNESS	1						

AT-146-2A 42095900046 UPPER

Pos No.	Parts No	Parts Name	Qty	Unit	Technical Data	Serial No (Start)	Serial No (End)	Remarks	Pages
100	42612851350	HARNESS	1						

AT-146-2A 42095900046 UPPER

Pos No.	Parts No	Parts Name	Qty	Unit	Technical Data	Serial No (Start)	Serial No (End)	Remarks	Pages
100	42354820200	HARNESS	1						

AT-146-2A 42095900046 UPPER

Pos No.	Parts No	Parts Name	Qty	Unit	Technical Data	Serial No (Start)	Serial No (End)	Remarks	Pages
3	16025153030	SPRING	1						
4	91000501500	O-RING	1		AS568-015				
5	91002802200	O-RING	1		1B P22				
6	91002801001	O-RING	1		1B P10A				
10	16025153020	SPRING	1						
14	91001001600	O-RING	2		1A S16				
30	36604750000	VALVE,RELIEF	1						

AT-146-2A 42095900046 UPPER
PI1140133-01 VALVE,CHECK

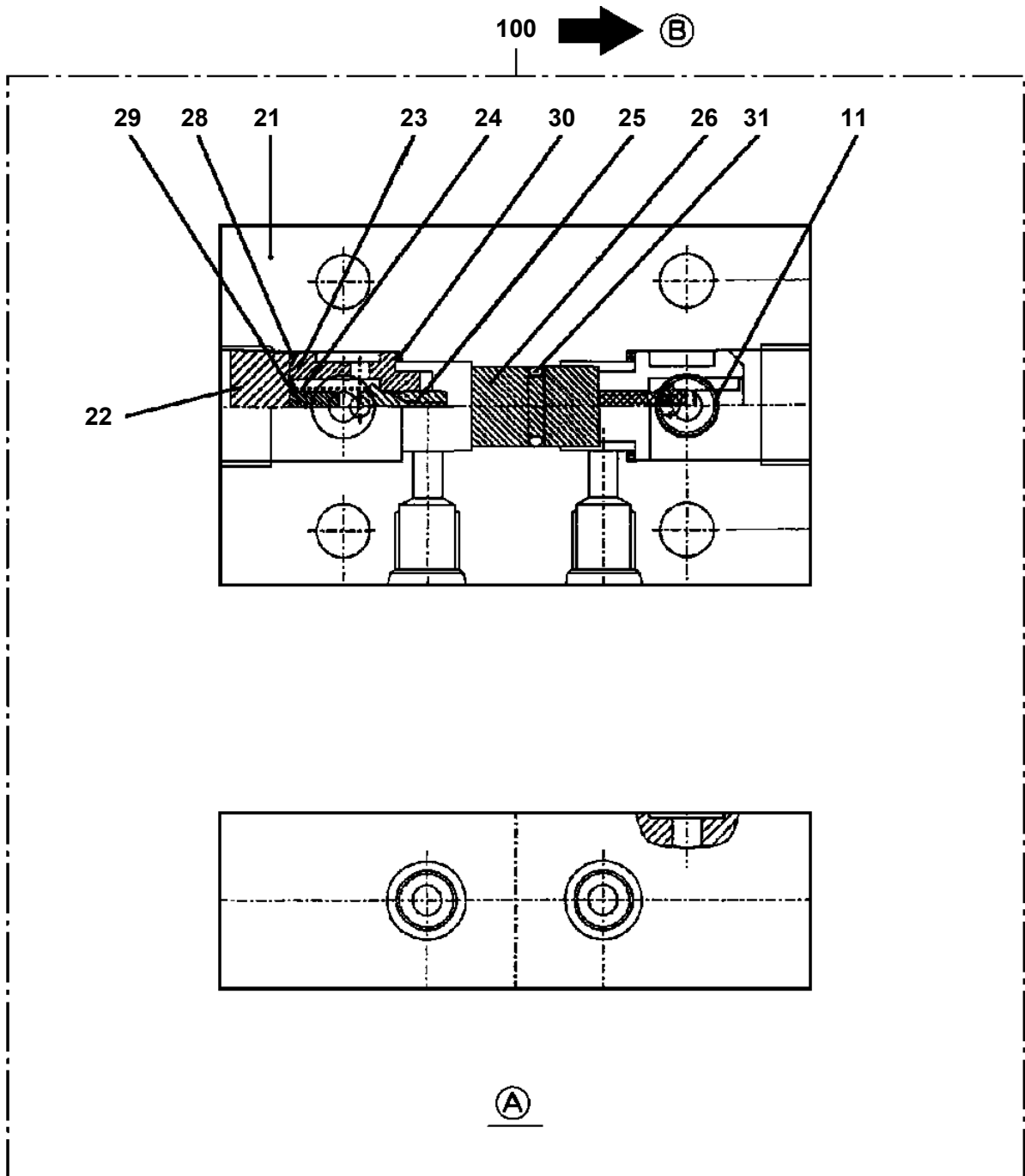

AT-146-2A 42095900046 UPPER

Pos No.	Parts No	Parts Name	Qty	Unit	Technical Data	Serial No (Start)	Serial No (End)	Remarks	Pages
12	91002801400	O-RING	2		1B P14				
100	36625740001	VALVE,CHECK	1						

AT-146-2A 42095900046 UPPER

Pos No.	Parts No	Parts Name	Qty	Unit	Technical Data	Serial No (Start)	Serial No (End)	Remarks	Pages
1	36672765020	BODY ASSY	1						
3	36672765030	CASE (LOWER)	1						
4	36672765080	ELEMENT	1						
5	36672765040	SPRING	1						
6	36672765050	PLUG (DRAIN)	1						
8	36672765060	PLUG	1						
9	91002908000	O-RING	1		1B G80				
10	91001103200	O-RING	1		1A P32				
11	91002801100	O-RING	1		1B P11				
12	91002801800	O-RING	1		1B P18				
13	91001101400	O-RING	1		1A P14				
14	91410108000	RING,BACKUP	1		T3 G80				
30	36672760000	FILTER,OIL	1						

**AT-146-2A 42095900046 UPPER
PJ3040024-00 OPE.ASSY**

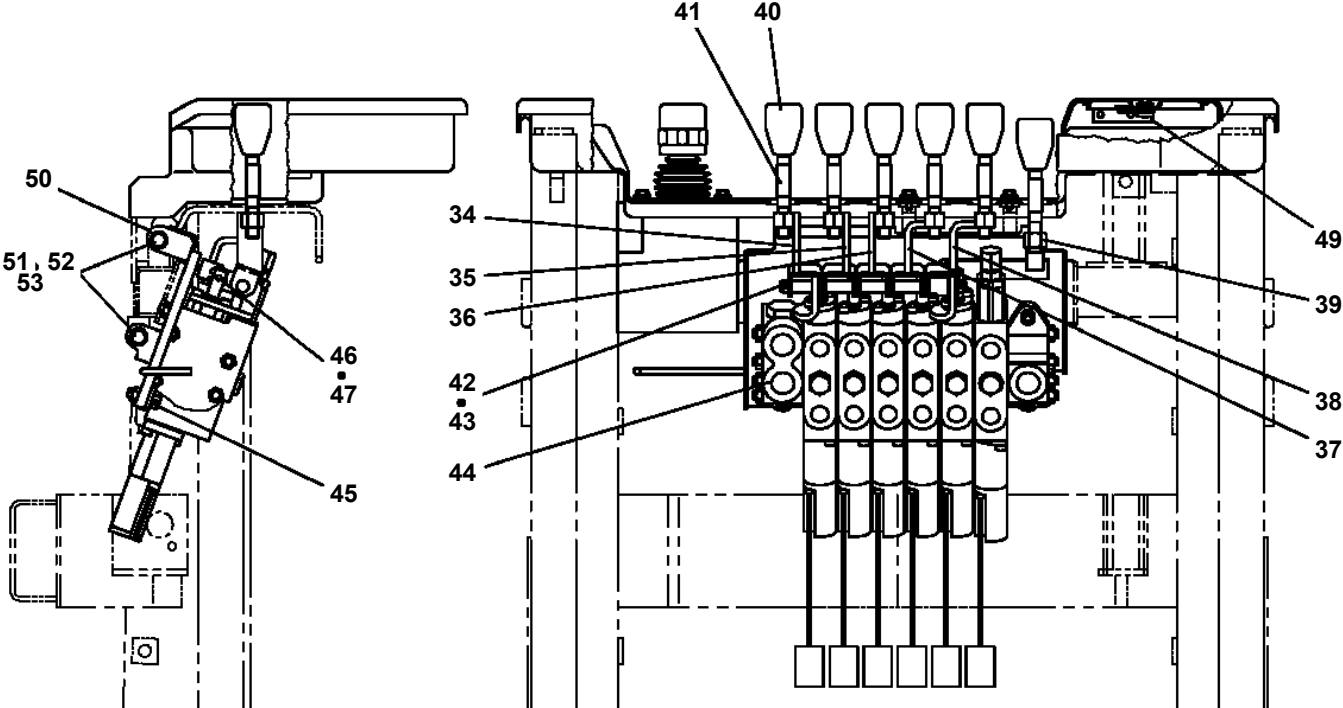
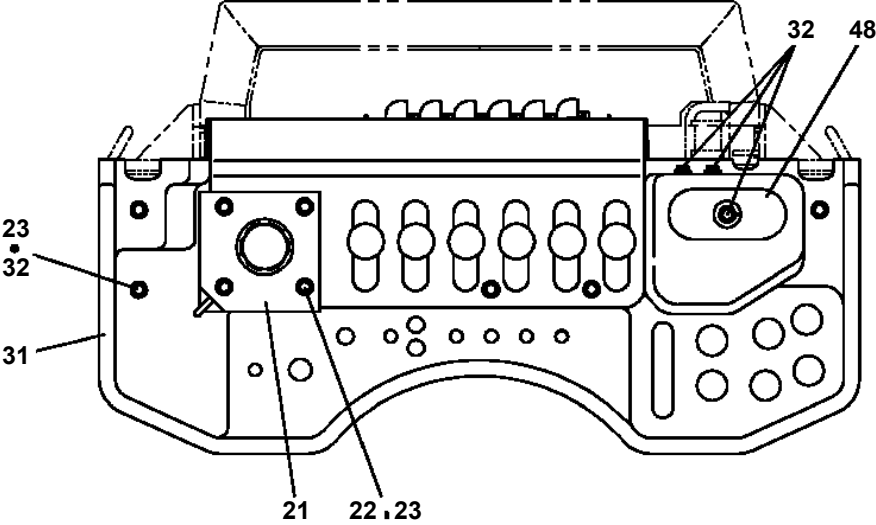

AT-146-2A 42095900046 UPPER

Pos No.	Parts No	Parts Name	Qty	Unit	Technical Data	Serial No (Start)	Serial No (End)	Remarks	Pages
1	42264601501	COVER	1						
2	90183108015	BOLT	23		M8X15				
3	42264601601	COVER	1						
4	42264601801	COVER	1						
5	42264601010	SUPPORT	1						
6	42264601701	COVER	1						
8	42265712100	COVER	1						
10	42263072100	COVER	1						
11	42264601101	COVER	1						
12	90183108020	BOLT	2		M8X20				
13	90183108030	BOLT	1		M8X30				
14	37000517000	PLATE	4						
22	82400000312	GROMMET	1	M	L=1000				

AT-146-2A 42095900046 UPPER

Pos No.	Parts No	Parts Name	Qty	Unit	Technical Data	Serial No (Start)	Serial No (End)	Remarks	Pages
1	42231711002	TABLE,SLEWING	1						
2	31630482500	CAP	1						
3	37001500250	BOLT	15		M16X70				
4	90303501601	WASHER,PLAIN	15		16				
5	37000507560	PLATE	1						
6	90171110022	BOLT	3		M10X22				
7	90302041001	WASHER,SPRING	7		10				
8	37000112690	PIN	1						
9	37000509190	PLATE	1						
10	90171112030	BOLT	2		M12X30				
11	90302041201	WASHER,SPRING	2		12				
12	37000175720	PIN	1						
13	42230210010	PIN	1						
14	37000505950	PLATE	1		T=3.2				
15	37000507730	PLATE	1						
16	90171320045	BOLT	1		M20X45				
17	90302042001	WASHER,SPRING	1		20				
18	42231270010	GROMMET	2						
19	42340240700	GROMMET	2						
20	82400000204	GROMMET	1		L=320				
21	82459103000	NIPPLE,GREASE	1		C-PT1/8				
22	82400000459	CAP	1						
23	42231713001	SUPPORT ASSY	1						
24	90101210022	BOLT	4		M10X22				
25	90201201000	NUT	4		M10				
26	90303071001	WASHER,PLAIN	4		10				

AT-146-2A 42095900046 UPPER

Pos No.	Parts No	Parts Name	Qty	Unit	Technical Data	Serial No (Start)	Serial No (End)	Remark
1	36661585030	SCREW	4					
2	36072725270	FLANGE	1					
7	36660375050	RACE (BEARING)	1					
8	36660375060	BEARING,THRUST NEEDLE	1					
15	36340345700	PLATE (SPACER)	1					
17	36081605280	COVER,END	1					
19	36663475020	SCREW	7					
24	36660375070	KEY	1		7X7X31.5			
32	36081605320	SPRING	1					
33	36660375160	PLUG (CAP)	2					
34	91001101100	O-RING	1		1A P11			
41	36663475030	SEAL KIT	1					
100	36663470001	MOTOR ASSY,OIL	1					

**AT-146-2A 42095900046 UPPER
PN1013475-02 ELEC.ASSY (CHARGER)**

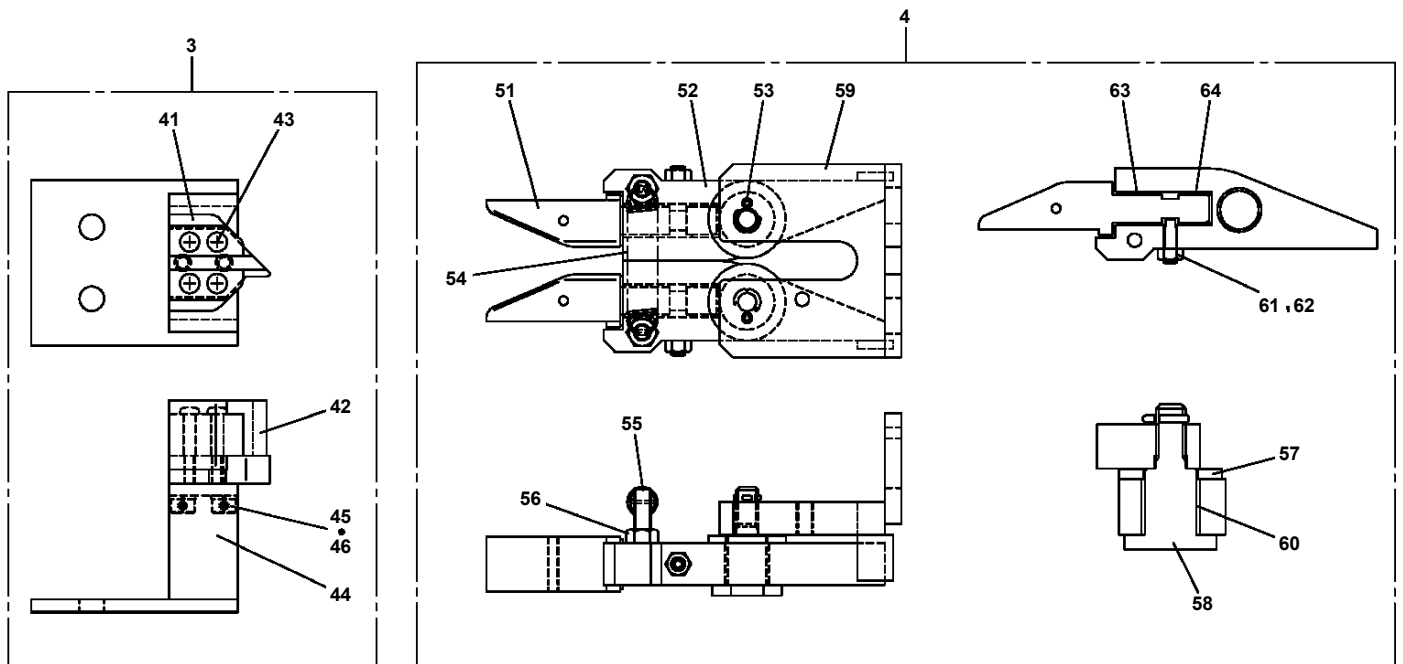

CLICK HERE TO **DOWNLOAD** THE COMPLETE MANUAL

- Thank you very much for reading the preview of the manual.
- You can download the complete manual from: www.heydownloads.com by clicking the link below



- Please note: If there is no response to CLICKING the link, please download this PDF first and then click on it.

CLICK HERE TO **DOWNLOAD** THE COMPLETE MANUAL

AT-146-2A 42095900046 UPPER

Pos No.	Parts No	Parts Name	Qty	Unit	Technical Data	Serial No (Start)	Serial No (End)	Rem
1	42736712100	SWITCH ASSY	1					
2	42501022100	HARNESS	1					
3	42501022200	HARNESS	1					
4	42420623600	LAMP ASSY (RED)	1					
5	91810132530	FASTENER	10					
6	42736712300	HARNESS	1					
7	82197518114	CAP (MATSUSHITA/BLACK)	1					
	82197518119	CAP (PLUS ONE MFG./BLACK)	1					
27	82105220236	SWITCH,TOGGLE	1					
34	82100002486	LAMP,PILOT	1					

**AT-146-2A 42095900046 UPPER
PN1080106-00 LAMP (BUCKET)**

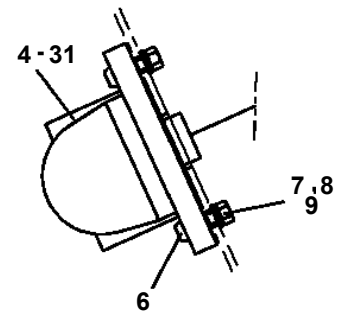
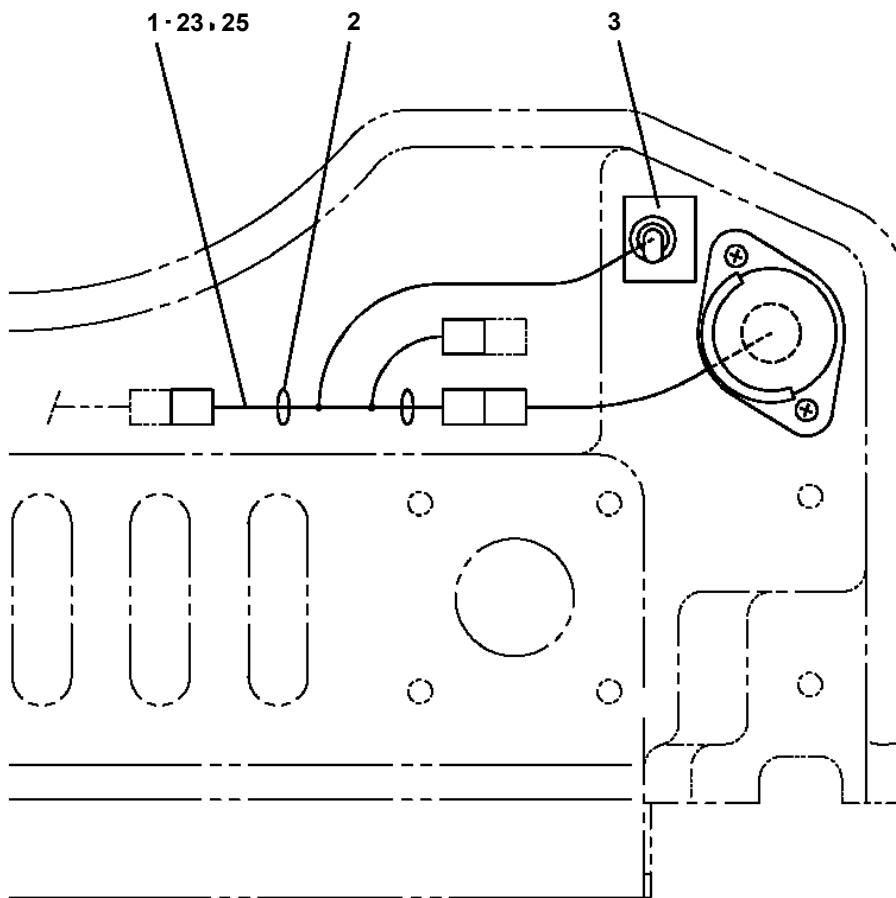

**AT-146-2A 42095900046 UPPER
PN1110364-00 RELAY ASSY**

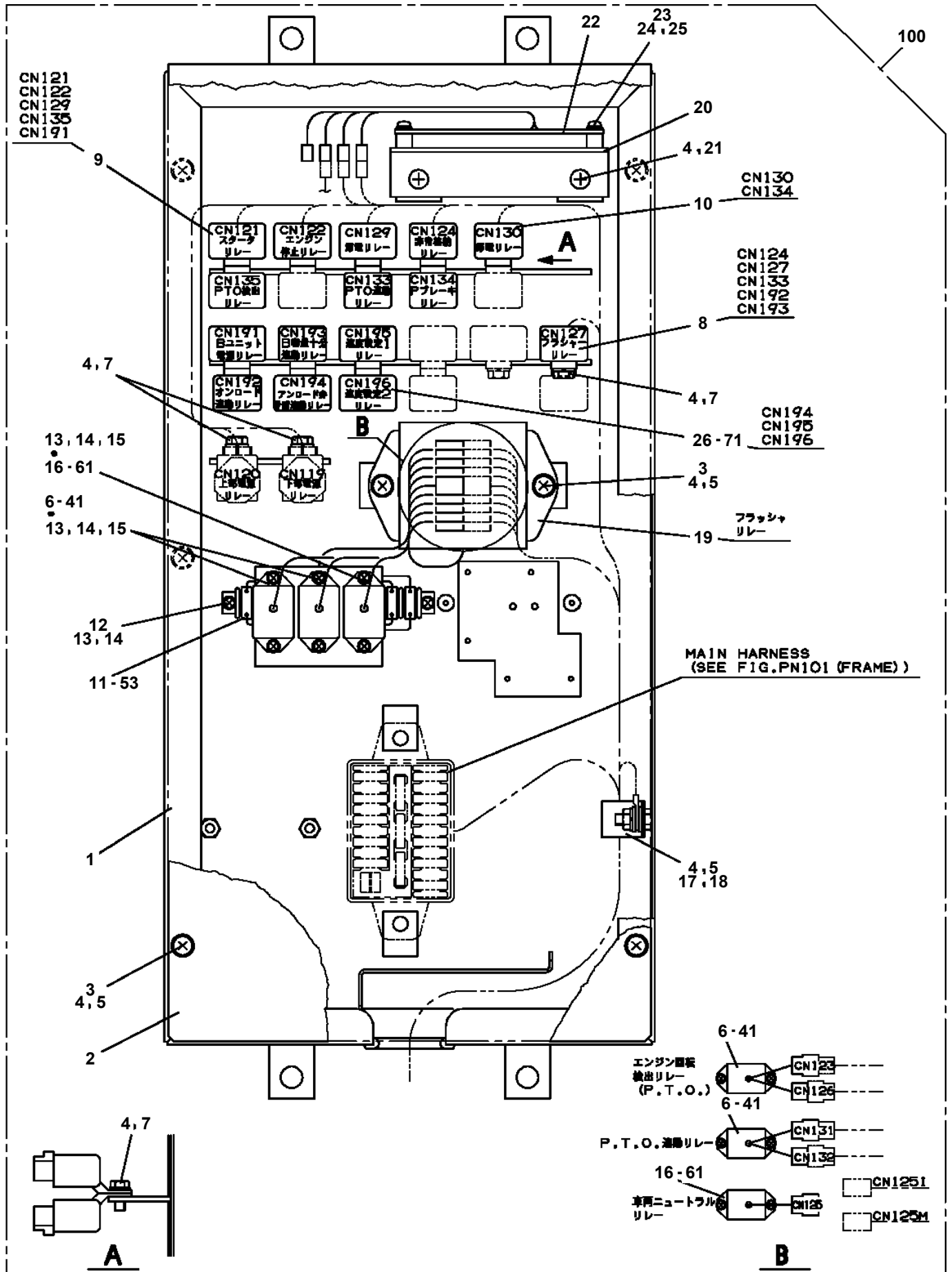

AT-146-2A 42095900046 UPPER
PN1350032-02 REEL, CORD

50

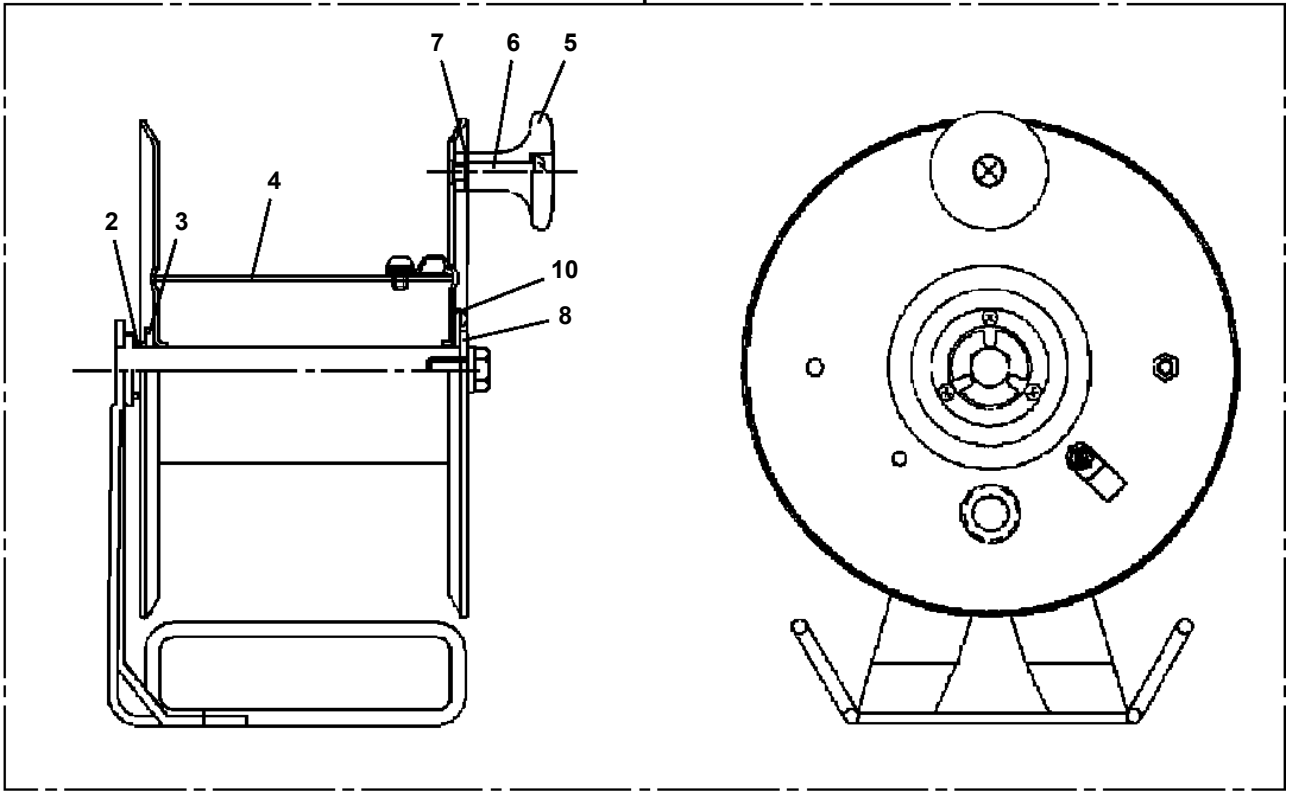

50

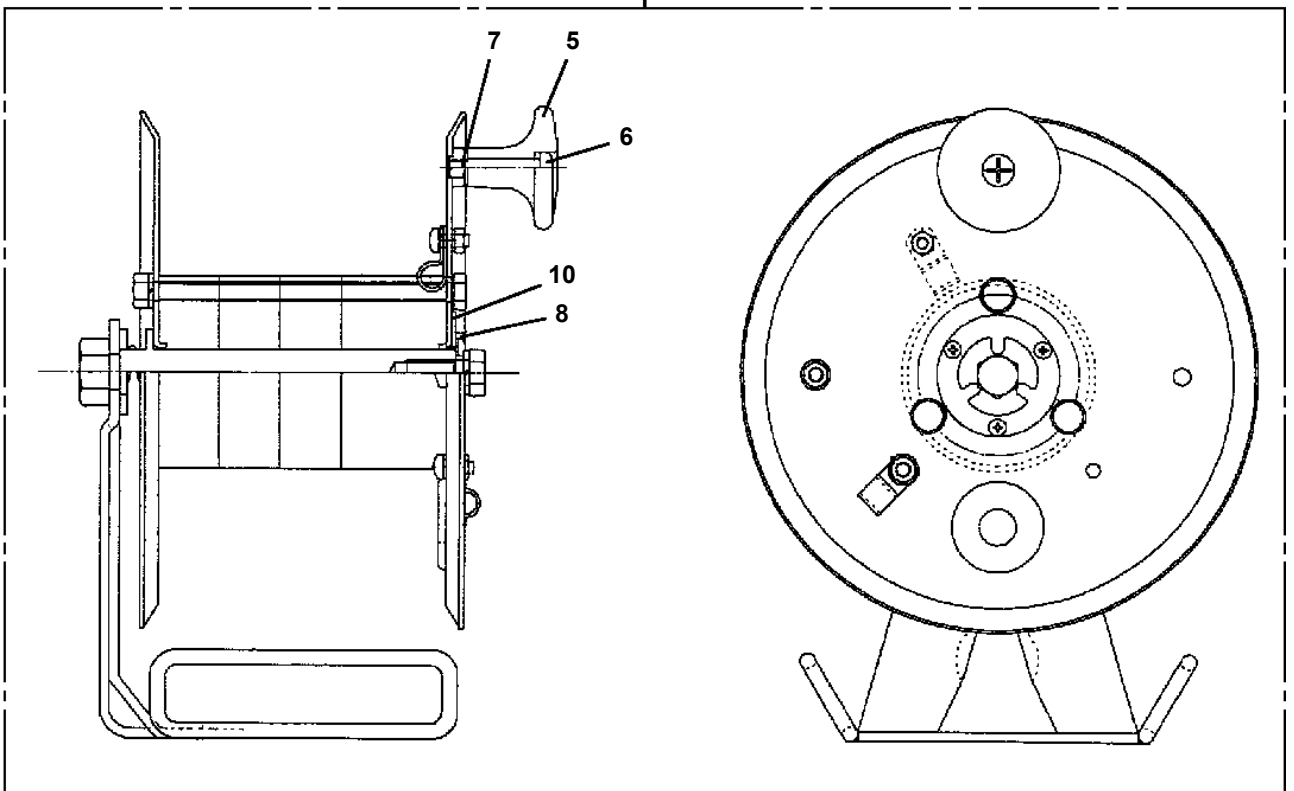

**AT-146-2A 42095900046 UPPER
PO1013871-01 PLATE ASSY,NAME (OUTRIGGER CONTROL)**

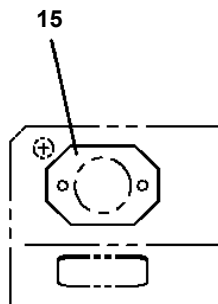
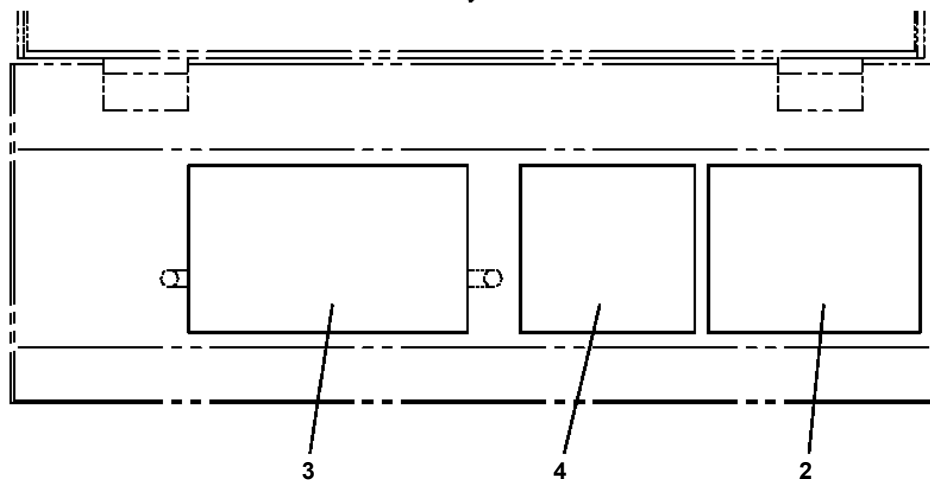
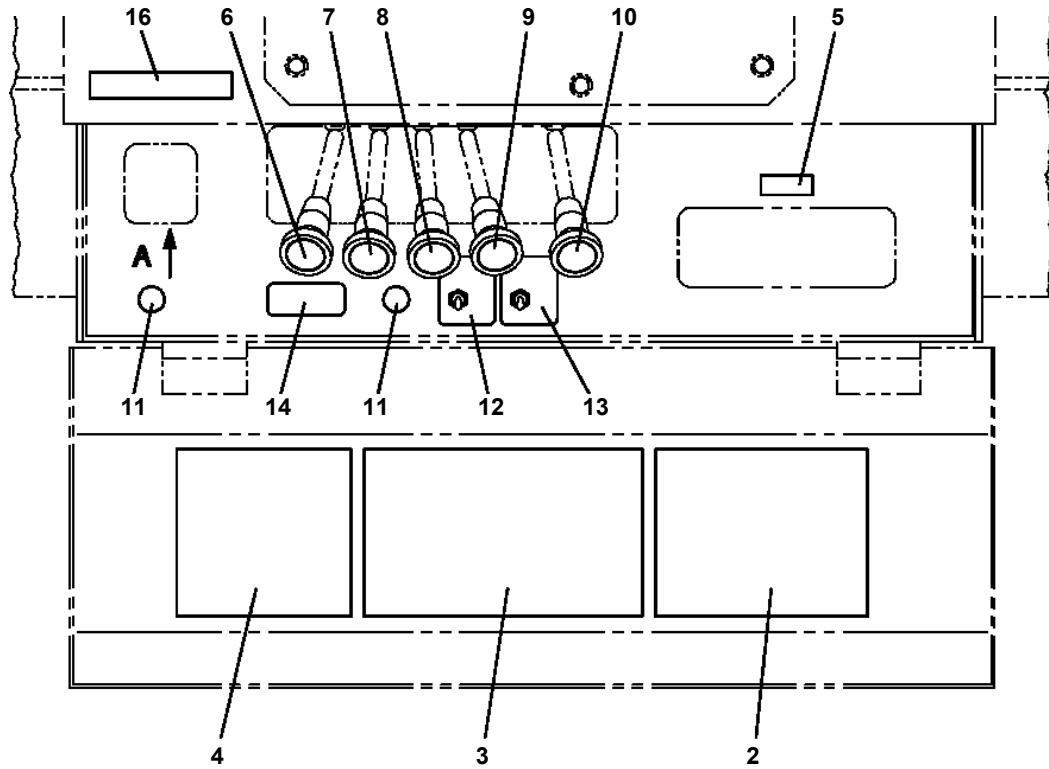

A

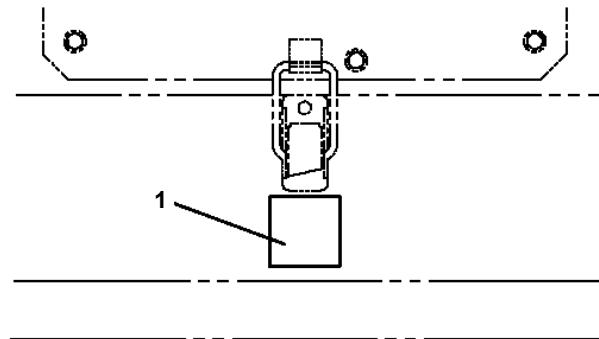

屏上面

AT-146-2A 42095900046 UPPER
PO1014245-00 PLATE ASSY,NAME

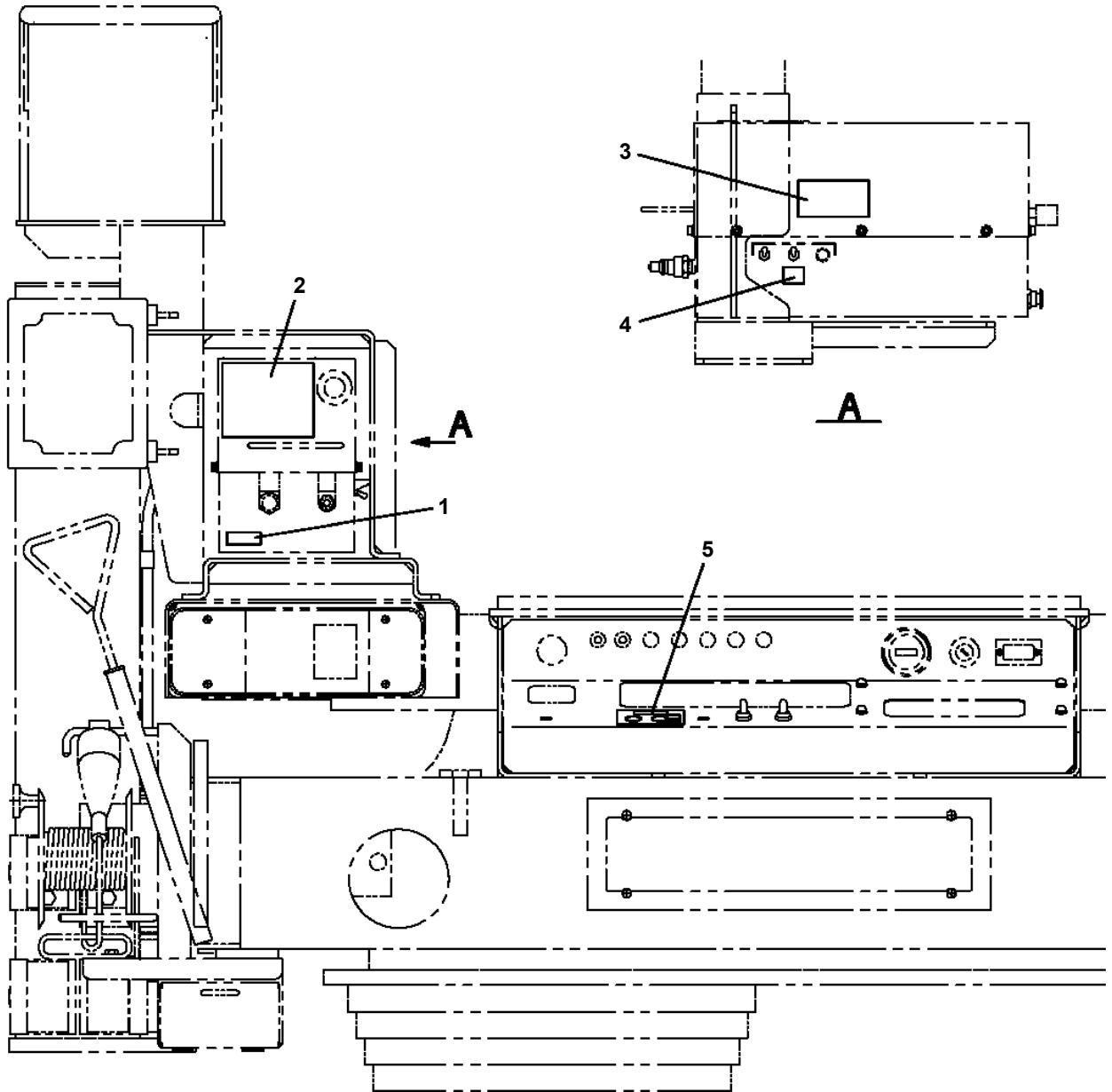

AT-146-2A 42095900046 UPPER

Pos No.	Parts No	Parts Name	Qty	Unit	Technical Data	Serial No (Start)	Serial No (End)	Ren
10	42738987600	HOSE ASSY	1					
100	42738981000	TANK ASSY (BATTERY,WATER)	1					

AT-146-2A 42095900046 UPPER

Pos No.	Parts No	Parts Name	Qty	Unit	Technical Data	Se
1	42470980100	SWITCH,PUSH	1			
2	82100002220	CABLE	5	M		
3	82100002173	CONNECTOR	1			
10	42470985000	SWITCH BOX (ELECTRIC BOOSTER, 5M,NANABOSI,SINKOU DENKI)	1			

AT-146-2A 42095900046 UPPER

Pos No.	Parts No	Parts Name	Qty	Unit	Technical Data	Serial No (Start)	Serial No (End)	Remarks
1	91991601013	ACCESSORIES (WRENCH)	1					

AT-146-2A 42095900046 UPPER

Pos No.	Parts No	Parts Name	Qty	Unit	Technical Data	Serial No (Start)	Serial No (End)	Remarks	Pages
1	42697861000	FENDER	1						
2	42697862000	FENDER	1				228135		
	42697865000	FENDER	1			228136			
3	42697863000	FENDER	1						
4	42697864000	FENDER	1				228135		
	42697866000	FENDER	1			228136			
5	42696894000	FENDER	1						
6	42696386000	FENDER	1						
7	90280200800	NUT,FLANGE	25		M8				
8	37000547660	PLATE	47		T=2.3				
9	90186208020	BOLT,FLANGE	2		M8X20				
25	82420102413	TRIM	2	M					

AT-146-2A 42095900046 UPPER

Pos No.	Parts No	Parts Name	Qty	Unit	Technical Data	Serial No (Start)	S
1	42738221000	WOOD BLOCK (KANSAI DENRYOKU/DETACHABLE)	1				

AT-146-2A 42095900046 UPPER
PX1350716-00 BOX, TOOL

100

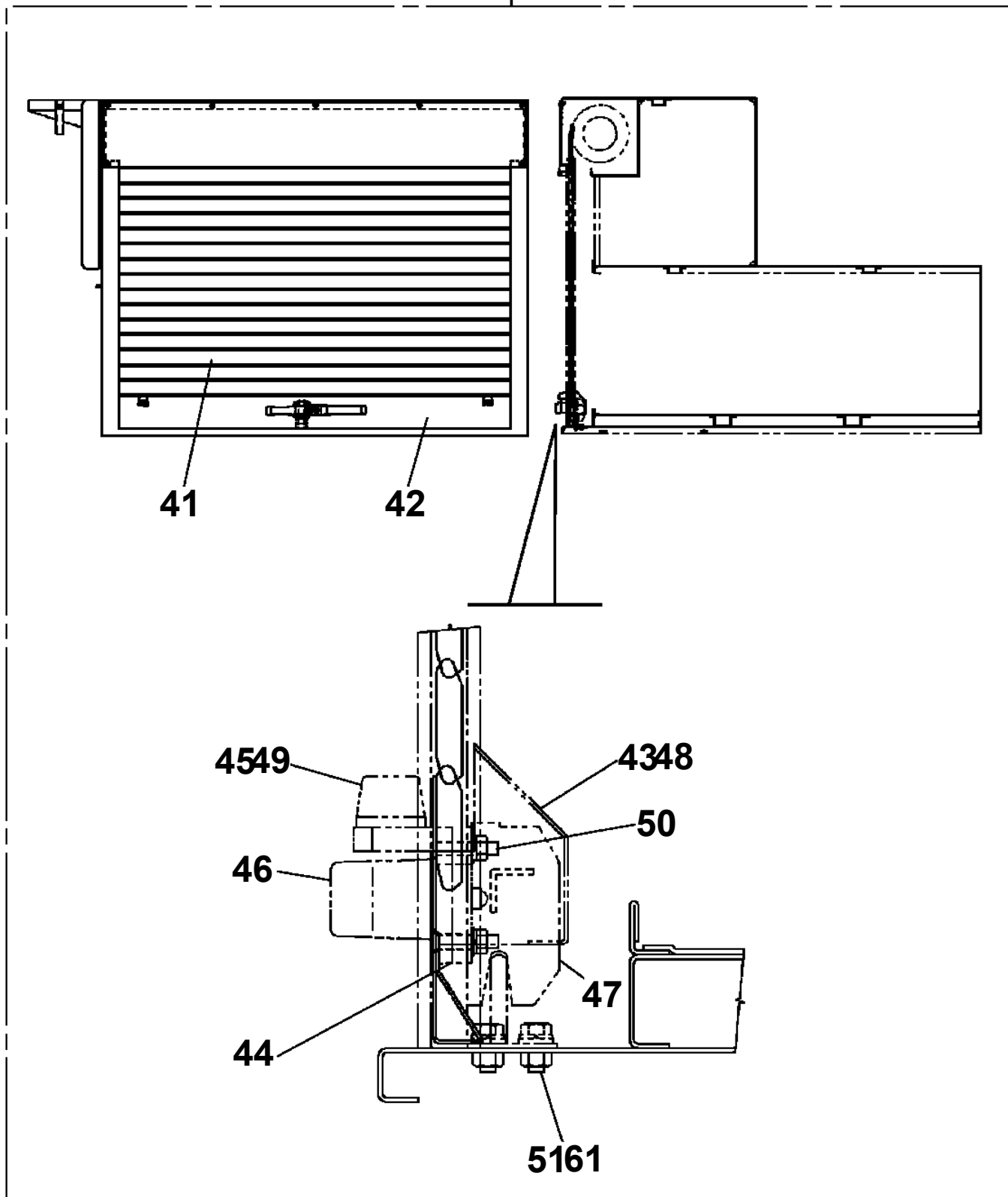

AT-146-2A 42095900046 UPPER

Pos No.	Parts No	Parts Name	Qty	Unit	Technical Data	Serial No (Start)	Serial No (End)	Remarks	Pages
1	42736872100	SUPPORT	1						
2	90101210020	BOLT	4		M10X20				
3	90302041001	WASHER,SPRING	4		10				

AT-146-2A 42095900046 UPPER

Pos No.	Parts No	Parts Name	Qty	Unit	Technical Data	Serial No (Start)	Serial No (End)	Re
1	42473857510	SCREW	4					
2	42473857515	SPRING	4					
3	80560053000	BALL,STEEL	4		1/8			
4	42470027510	HEAD (SCM)	1					
5	42473857530	SPRING	1					
6	42473857535	PIN	1					
7	42470027520	COLLAR	1					
8	42473857545	SPRING	1					
9	42473857550	PISTON	1					
10	91411003500	RING,BACKUP	1					
11	91001103500	O-RING	1		1A P35			
12	42470027530	CYLINDER	1					
13	42473857570	HOLDER	1					
14	42473857575	CAP	1					
15	91001101400	O-RING	1		1A P14			
16	42473857580	CAP	1					
17	42473857590	COVER	1					
18	42473857595	BUTTON (PUSH)	1					
19	42473857600	SPRING	1					
20	42473857605	SWITCH	1					
21	42473857610	HOLDER (SWITCH)	1					
22	42473857615	SCREW	1					
24	42473857620	BINDER	4					
25	42473857625	TUBE	1					
26	42473857630	TUBE	1					
27	42473857635	TUBE	1					
28	42473857640	BINDER	6					
29	42473857645	HOSE	1					
30	42473857650	JOINT	1					
31	42473857655	CABLE	1					
32	82100002173	CONNECTOR	1					
38	80136320010	PIN,SPLIT	1		2X10			
39	42473857675	SEPARATOR	1					
61	42473857670	PROTECTOR ASSY	1					
62	42473857690	CLAMP ASSY	1					
100	42470020000	CLAMP HEAD (IZUMI 8TON,2.5M)	1					

AT-146-2A 42095900046 UPPER

Pos No.	Parts No	Parts Name	Qty	Unit	Technical Data	Serial No (Start)	Serial No (End)
1	42470367510	HOOK	1				
2	42470367520	CYLINDER	1				
3	42470367530	HOLDER (DIES)	1				
4	42470367540	STEM	1				
5	42470367550	SPRING (RETURN)	1				
6	42470367560	SEAT,SPRING	1				
7	42470367570	RING,STOP	1				
8	80720103006	PIN,SPRING	1		3X6		
9	91001104000	O-RING	1		1A P40		
10	42470367580	RING (B)	1				
12	42470367590	NOTCH	1				
13	42470367600	PIECE (B)	1				
14	42470367610	PIN (SCREW)	1				
15	42470367620	SPRING ASSY	1				
16	42470367630	PIECE (AL)	1				
17	42470367640	SPRING	1				
18	42470367650	KNOB	1				
19	80720102012	PIN,SPRING	1		2X12		
20	80720103008	PIN,SPRING	1		3X8		
21	42470367660	GUIDE	1				
22	90131505008	BOLT,HEXAGON SOCKET	1		M5X8		
23	90304110501	WASHER (LOCK)	1		5		
24	42470367670	SCRAPER	1				
25	42470367680	SPACER	1				
26	42470367690	BOLT,HEXAGON SOCKET	1				
27	42470367700	NIPPLE	1				
28	42470367710	JOINT,SELF SEALING (WITH CAP)	1				
29	42470367720	GRIP	1				
30	42470367730	PLATE,NAME	1				
31	42470367740	COVER (SAFETY)	1				
50	42470361000	CLAMP HEAD ASSY (SANWA,12TON)	1				

AT-146-2A 42095900046 UPPER

Pos No.	Parts No	Parts Name	Qty	Unit	Technical Data	Serial No (Start)	Serial No (End)	F
1	42470530000	CUTTER HEAD (IZUMI 6.4TON AIR)	1					
2	42470537510	BOLT	2					
3	42470537520	NUT	2		M8			

AT-146-2A 42095900046 UPPER

Pos No.	Parts No	Parts Name	Qty	Unit	Technical Data	Serial No (Start)	Serial No (End)	R
1	42470050000	ROPE (SAFETY,1.5M,WITH HOOK)	1					

AT-146-2A 42095900046 UPPER

Pos No.	Parts No	Parts Name	Qty	Unit	Technical Data	Serial No (Start)	Serial No (End)	Remarks	Pages
1	42470121000	ARM ASSY	1						
2	42470421000	HOLDER	3						
3	42470123000	CLAMP ASSY	1						
4	42470044000	HOT STICK	1						
5	42470045000	SUPPORT	1						
6	90101216130	BOLT	1		M16X130				
7	90303071601	WASHER,PLAIN	2		16				
8	90201201600	NUT	2		M16				
9	42220011200	SUPPORT	1						
21	42470121100	ARM	1						
22	42470121200	CAP	2						

AT-146-2A 42095900046 UPPER

Pos No.	Parts No	Parts Name	Qty	Unit	Technical Data	Serial No (Start)	Serial No (End)	Remarks	Pages
1	42470121000	ARM ASSY	1						
2	42470421000	HOLDER	3						
3	42470123000	CLAMP ASSY	1						
4	42475751001	SUPPORT	1						
5	90101216150	BOLT	1		M16X150				
6	90303071601	WASHER,PLAIN	2		16				
7	90201201600	NUT	2		M16				
8	42220011200	SUPPORT	1						
21	42470121100	ARM	1						
22	42470121200	CAP	2						

AT-146-2A 42095900046 UPPER

Pos No.	Parts No	Parts Name	Qty	Unit	Technical Data	Serial No (Start)	Serial No (End)	Re
1	42478182010	PLATE,NAME	1					
2	42736070100	SWITCH ASSY (WITH HARNESS)	1					
3	42476321100	CABLE ASSY	1		L=1000			
4	42392583090	PLATE,CAUTION	1					
5	82100001802	TUBE,CORRUGATE	1	M	10			
6	42478151100	HARNESS	1					
7	82100000665	CAP (BLACK)	1					
8	91810132530	FASTENER	20					
9	42478171100	HARNESS	1					
10	42475521300	CABLE ASSY	1		L=1000			
11	82100001411	TUBE,SPIRAL	1	M	SE-08BK	228070		
31	82105220112	SWITCH,TOGGLE	1					
46	82117732504	CONNECTOR	2					
47	82100001655	CAP	2					

AT-146-2A 42095900046 UPPER

Pos No.	Parts No	Parts Name	Qty	Unit	Technical Data	Serial No (Start)	Serial No (End)	Remarks
1	80316070060	PLUG	1		PF3/8			
2	91002801400	O-RING	1		1B P14			
3	80316070040	PLUG	2		PF1/4			
4	91002801100	O-RING	2		1B P11			
5	44320516500	PLUG (12 POLES,FEMALE)	1					
6	42475910010	PLATE,NAME	1					
7	90101208016	BOLT	4		M8X16			
8	90302040801	WASHER,SPRING	4		8			
9	42478190100	WEIGHT	1					

AT-146-2A 42095900046 UPPER

Pos No.	Parts No	Parts Name	Qty	Unit	Technical Data	Serial No (Start)	Serial No (End)	Re
1	(*****)	BOOSTER (AIR&ELECTRIC)	1					
2	(*****)	BOOSTER (WIRING/ELECTRIC)	1					
3	(*****)	BOOSTER (PIPING/AIR&ELECTRIC)	1					

AT-146-2A 42095900046 UPPER

Pos No.	Parts No	Parts Name	Qty	Unit	Technical Data	Serial No (Start)	Serial No (End)	R
1	42503770100	SUPPORT	1				228026	
	42501020100	SUPPORT	1			228027		
3	90101208025	BOLT	9		M8X25			
4	90302040801	WASHER,SPRING	9		8			
5	42502730301	SUPPORT	1					
6	(*****)	PIPING	1					
7	(*****)	ELEC.ASSY	1					
10	42501020400	SUPPORT	1					
11	(*****)	PLATE ASSY,NAME	1					
12	(*****)	MOUNT,SUPPORT (COLOR CONE)	1					
15	42736631000	CABLE ASSY	1					
16	42772470100	WEIGHT	1					
17	90171110025	BOLT	4		M10X25			
18	42503770200	PLATE	2					
41	82100002173	CONNECTOR	1					
43	82117920411	CONNECTOR	1					
44	82100001219	INSULATOR	8					
45	82122910400	CAP	1					

AT-146-2A 42095900046 UPPER

Pos No.	Parts No	Parts Name	Qty	Unit	Technical Data	Serial No (Start)	Serial No (End)	Remarks	Pages
1	42476201000	LAMP	1		12V 60W				
2	90101212020	BOLT	1		M12X20				
3	37000159530	PIN	1						
4	80620210160	PIN,SNAP	1						
5	90302041201	WASHER,SPRING	1		12				
10	42476200000	LAMP ASSY	1						

AT-146-2A 42095900046 UPPER

Pos No.	Parts No	Parts Name	Qty	Unit	Technical Data	Serial No (Start)	Serial No (E
1	(*****)	BOOSTER (AIR&ELECTRIC)	1				
2	(*****)	BOOSTER (WIRING/ELEC.SELECTOR)	1				
3	(*****)	BOOSTER (PIPING/AIR ELEC.,NANABOSHI)	1				

AT-146-2A 42095900046 UPPER

Pos No.	Parts No	Parts Name	Qty	Unit	Technical Data	Serial No (Start)	Serial No (E
1	80456210600	JOINT,SELF SEALING	1				
2	42470367750	HOSE ASSY	1		3M		
3	42470362100	JOINT,SELF SEALING	1				
4	42470367770	HOSE,AIR	1		3M		
5	42470362200	PUMP	1				
6	80456240600	JOINT,SELF SEALING (WITH DUST CAP)	1				
7	42470367840	TUBE	2		25X0.15M		
8	42470367780	JOINT	1				
21	42471437520	CAP	1				
50	42470362000	HOSE,BOOSTER	1		L=3000		

AT-146-2A 42095900046 UPPER

Pos No.	Parts No	Parts Name	Qty	Unit	Technical Data	Serial No (Start)	Serial No (E
5	80456210600	JOINT,SELF SEALING	1				
6	80456240600	JOINT,SELF SEALING (WITH DUST CAP)	1				
11	42471437520	CAP	1				
30	42471085000	HOSE,BOOSTER (MALE-FEMALE,5M)	1				

AT-146-2A 42095900046 UPPER

Pos No.	Parts No	Parts Name	Qty	Unit	Technical Data	Serial No (Start)	Serial No (End)	Remarks
2	42460011010	EARTH	1					
3	90101208012	BOLT	2		M8X12			
4	90302040801	WASHER,SPRING	2		8			
5	90101210016	BOLT	4		M10X16			
6	90302041001	WASHER,SPRING	4		10			
7	42738760100	SUPPORT	1					
21	36160650000	REEL,CORD	1					
22	42733030100	CABLE ASSY	1		L=20100			
23	82124331000	CLIP (WITH CAP/BLACK)	1					
24	90201200500	NUT	1		M5			
25	90302040501	WASHER,SPRING	1		5			
26	90303070501	WASHER,PLAIN	1		5			
41	42733317510	CAP	1					

AT-146-2A 42095900046 UPPER

Pos No.	Parts No	Parts Name	Qty	Unit	Technical Data	Serial No (Start)	Serial No (End)	Remarks	Pages
1	42474970100	PLATE	2						

AT-146-2A 42095900046 UPPER

Pos No.	Parts No	Parts Name	Qty	Unit	Technical Data	Serial No (Start)	Serial No (End)	Remarks
1	42475930000	HANGER (FOR BUCKET,FRP)	1					

CLICK HERE TO **DOWNLOAD** THE COMPLETE MANUAL

- Thank you very much for reading the preview of the manual.
- You can download the complete manual from: www.heydownloads.com by clicking the link below



- Please note: If there is no response to CLICKING the link, please download this PDF first and then click on it.

CLICK HERE TO **DOWNLOAD** THE COMPLETE MANUAL