

LASER 130

ACCESSORIES

GENERAL

AUXILIARY HYDRAULIC DISTRIBUTOR.....	0E.00.1
AUXILIARY HYDRAULIC DISTRIBUTOR.....	0E.00.2
AUXILIARY HYDRAULIC DISTRIBUTOR.....	0E.00.3
HYDRAULIC DISTRIBUTOR-PARTS.....	0E.00.4
HYDRAULIC DISTRIBUTOR-PARTS.....	0E.00.5
HYDRAULIC DISTRIBUTOR-PARTS.....	0E.00.6
HYDRAULIC DISTRIBUTOR-PARTS.....	0E.00.7
HYDRAULIC CYLINDERS.....	0E.00.8
HYDRAULIC CYLINDERS.....	0E.00.10
3 POINT HITCH.....	0E.00.18
3 POINT HITCH.....	0E.00.19
3 POINT HITCH.....	0E.00.20
3 POINT HITCH.....	0E.00.21
3 POINT HITCH.....	0E.00.22
3 POINT HITCH.....	0E.00.23
TOWING BAR.....	0E.00.24
PERMANENT REAR TOWING HITCH.....	0E.00.25
FRONT TOWING HITCH.....	0E.00.26
BALLAST.....	0E.00.27
FRONT BALLAST.....	0E.00.29
REAR BALLAST.....	0E.00.30
REAR OSCILLATING HITCH.....	0E.00.32
REAR OSCILLATING HITCH.....	0E.00.33
P.T.O. GUARD.....	0E.00.34
PREARRANGED FOR RADIO INSTALLATION.....	0E.00.35
PREARRANGED FOR RADIO INSTALLATION.....	0E.00.36
HYDRAULIC BREAKING FOR TRAILER.....	0E.00.37
VALVE PARTS.....	0E.00.38
TOOL POUCH.....	0E.00.39

CLICK HERE TO **DOWNLOAD** THE COMPLETE MANUAL

- Thank you very much for reading the preview of the manual.
- You can download the complete manual from: www.heydownloads.com by clicking the link below



- Please note: If there is no response to CLICKING the link, please download this PDF first and then click on it.

CLICK HERE TO **DOWNLOAD** THE COMPLETE MANUAL

Section: ACCESSORIES
HYDRAULIC CYLINDERS

Fig.	Code	QTY	Name
19	0.98609.50.3/10	1	tube (...) <- " A "
19	0.98609.50.3/20	1	tube -> (...) " B "
20	2.1560.014.0	1	gasket 18.2 x 24 x 1.5

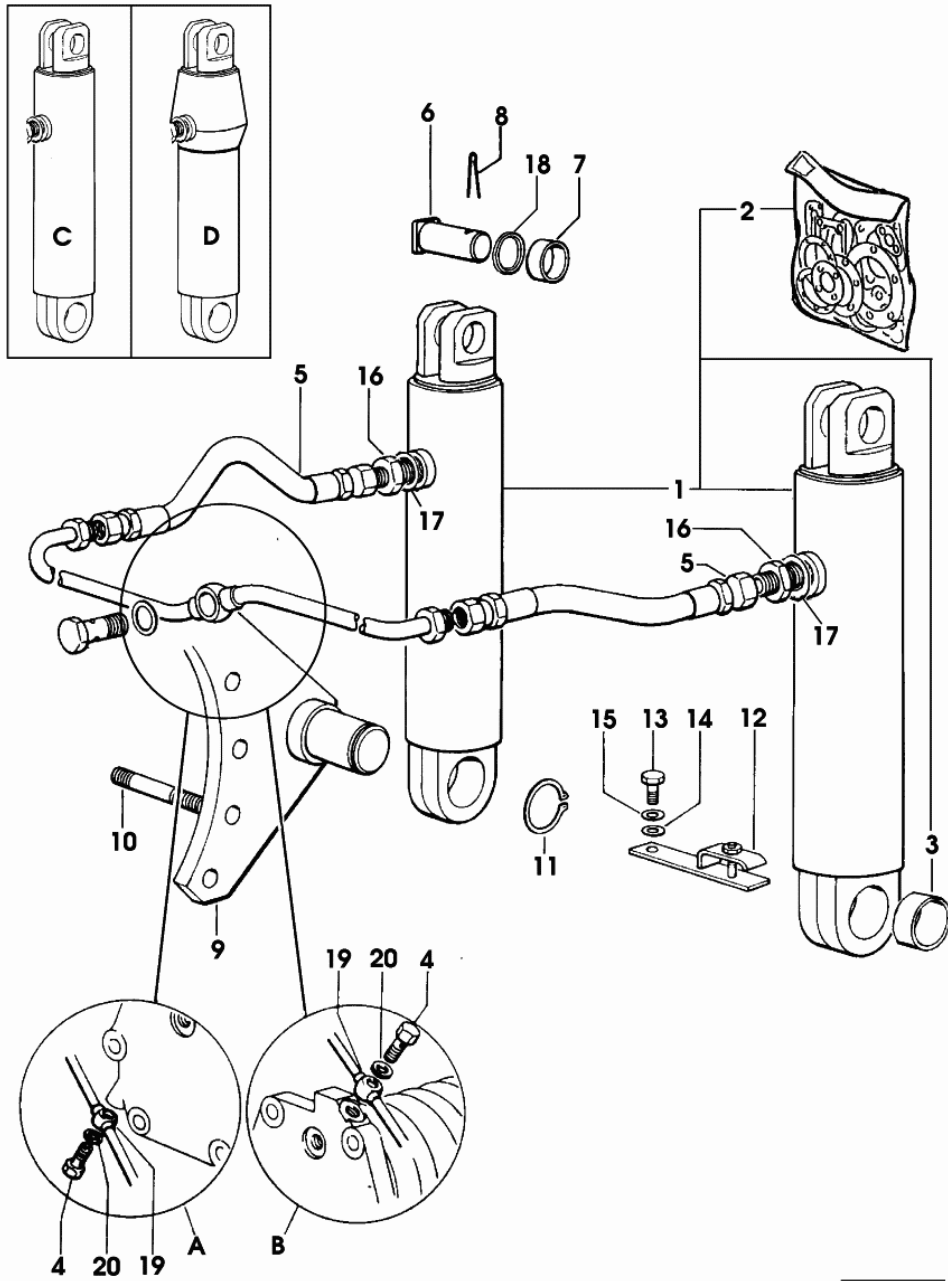

258_369

3 POINT HITCH

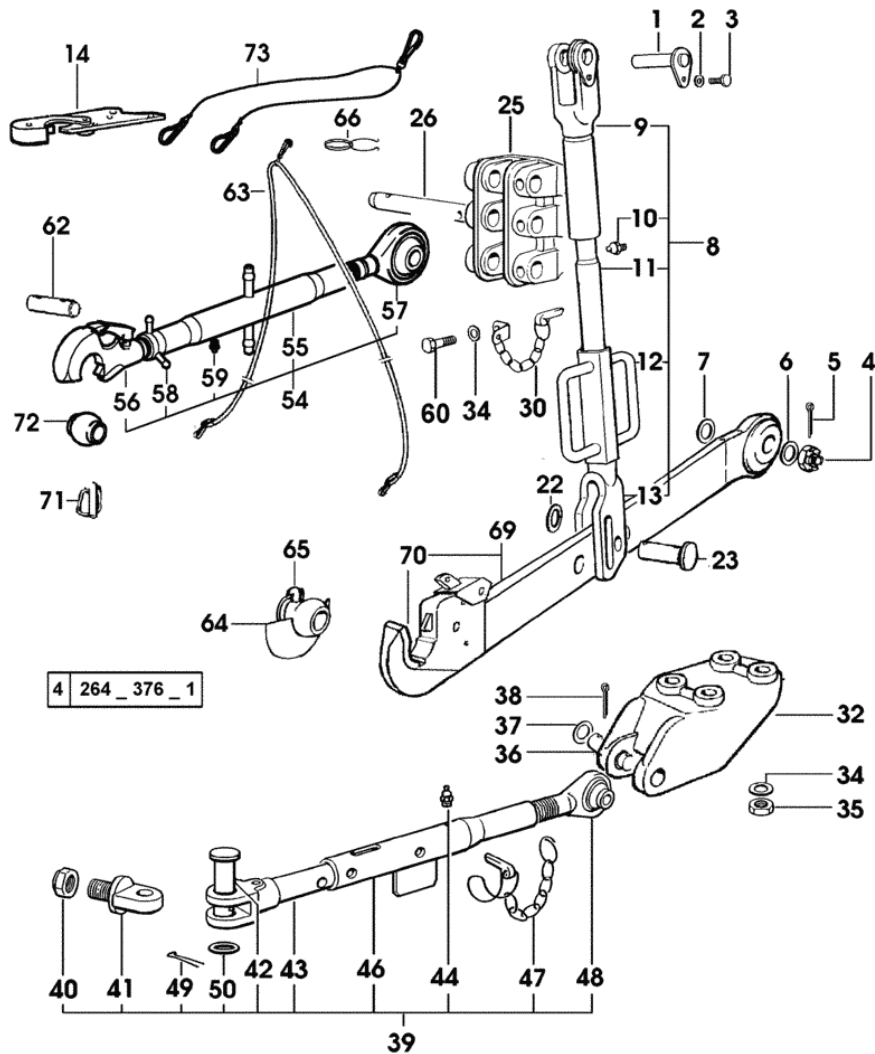

Fig.	Code	QTY	Name
------	------	-----	------

Notes:

-> 4179 X 130HP -> 3796 X 150HP

1	0.009.3144.2	2	pin
2	2.1470.007.2	2	lock washer 12
3	2.0112.409.2	2	screw m 12 p.1.75 x 25
4	2.1021.209.2	1	castellated nut m 20 p.1.5
5	2.1690.413.2	2	split pin 4 x 36
6	0.96081.52.0/10	2	snoulder
7	0.96081.53.0	2	snoulder
8	0.010.4798.4/10	2	adjustable tensioner
9	0.010.4789.3/10	1	rod
10	2.3820.105.2	1	lubricator m 10 p.1 x 7
11	0.010.4797.2/10	1	sleeve
12	0.010.4008.2	1	tube
13	0.010.4009.3/10	1	rod
14	0.760.3856.3/10	1	stop
22	2.1311.015.2	4	flat washer 28
23	2.1679.082.2	2	pin
25	0.760.3810.0/50	1	flange
26	0.760.2212.0	1	piston pin
30	0.760.2257.3	1	pin
32	0.010.6427.0	1	bracket sx/lh/li
32	0.010.6426.0	1	bracket dx/rh/re
34	2.1470.010.2	8	lock washer 18
34	2.1470.009.2	6	lock washer 16
35	2.1011.410.2	8	nut m 18 p.1.5
36	2.1679.031.2/10	2	pin mm 25.4 x 143
37	2.1311.015.2	4	flat washer 28
38	2.1690.413.2	2	split pin 4 x 36
39	0.010.5222.4/10	2	stabiliser
40	2.1011.412.2	1	nut m 24 p.2
41	0.96063.52.0/10	1	pin
42	2.1679.085.2	1	pin
43	0.010.5217.3	1	rod
44	2.3820.105.2	1	lubricator m 10 p.1 x 7
46	0.010.5228.2	1	tube
47	0.009.7076.4	1	small chain
48	0.010.5226.3/10	1	rod dx/rh/re
49	2.1690.513.2	1	split pin 5 x 36
50	2.1311.014.2	1	flat washer Ø 25
54	0.011.3995.4/10	1	top link 3 cat.- WALTERSCHEID
55	0.011.3995.3	1	sleeve
56	0.011.3996.3	1	rod 3 cat.- WALTERSCHEID

Section: ACCESSORIES
REAR OSCILLATING HITCH

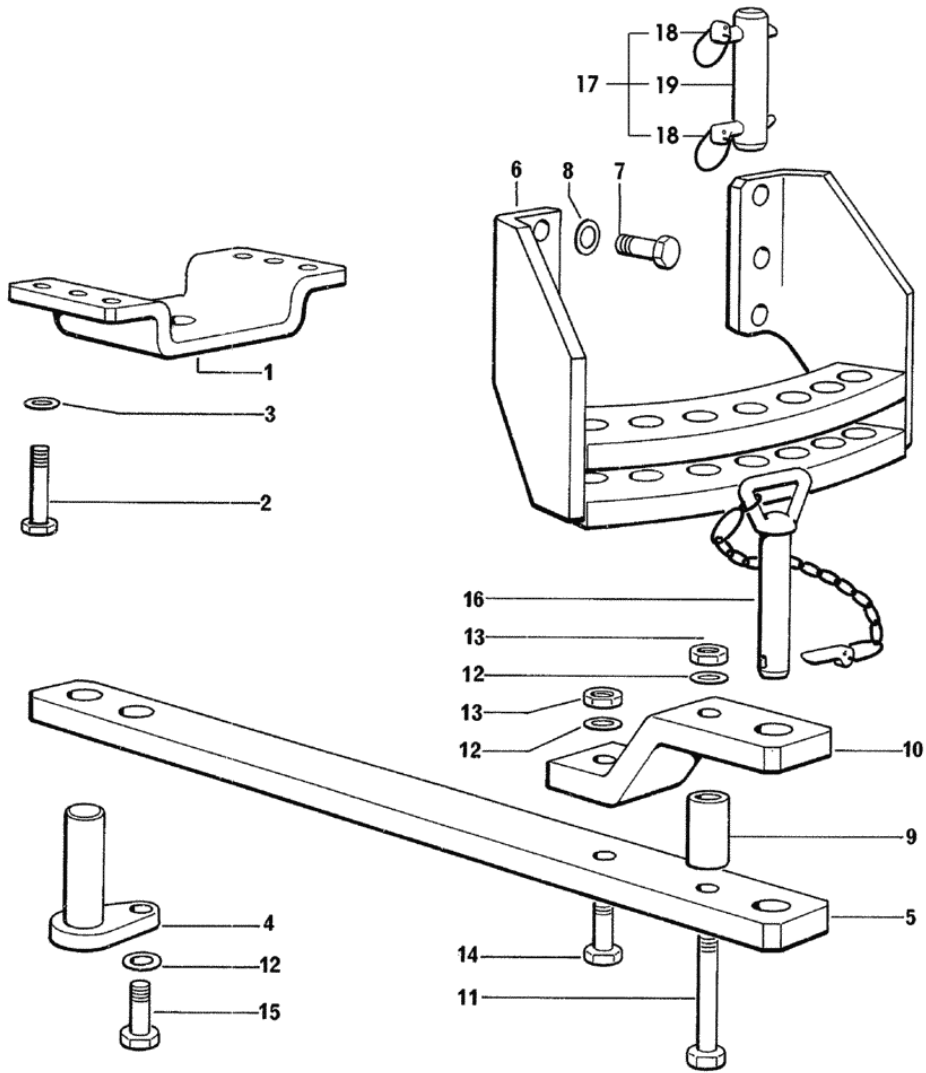

Fig.	Code	QTY	Name
------	------	-----	------

Notes:
 (...) <-

1	0.97317.50.0	1	support
2	2.0112.615.2	6	screw m 16 p.2 x 40
3	2.1470.009.2	6	lock washer 16
4	0.97317.51.2	1	pin
5	0.97308.20.0	1	draw bar
6	0.97318.10.2	1	sector
7	2.0112.620.2	6	screw m 16 p.2x55
8	2.1470.009.2	6	lock washer 16
9	2.1579.233.2	1	spacer 18x35x75
10	0.97308.52.0	1	plate
11	2.0112.641.2	1	screw m 16 p.2x160
12	2.1470.009.2	3	lock washer 16
13	2.1011.109.2	2	nut m 16 p.2
14	2.0112.626.2	1	screw m 16 p.2x85
15	2.0122.609.2	1	screw m 16 p.1.5x25
16	0.97306.30.3	1	pin
17	0.97306.32.6	2	pin
18	0.010.9322.4	4	pin Ø 11
19	2.1669.031.2	2	pin

258_385

Section: BODY WORK
HOOD

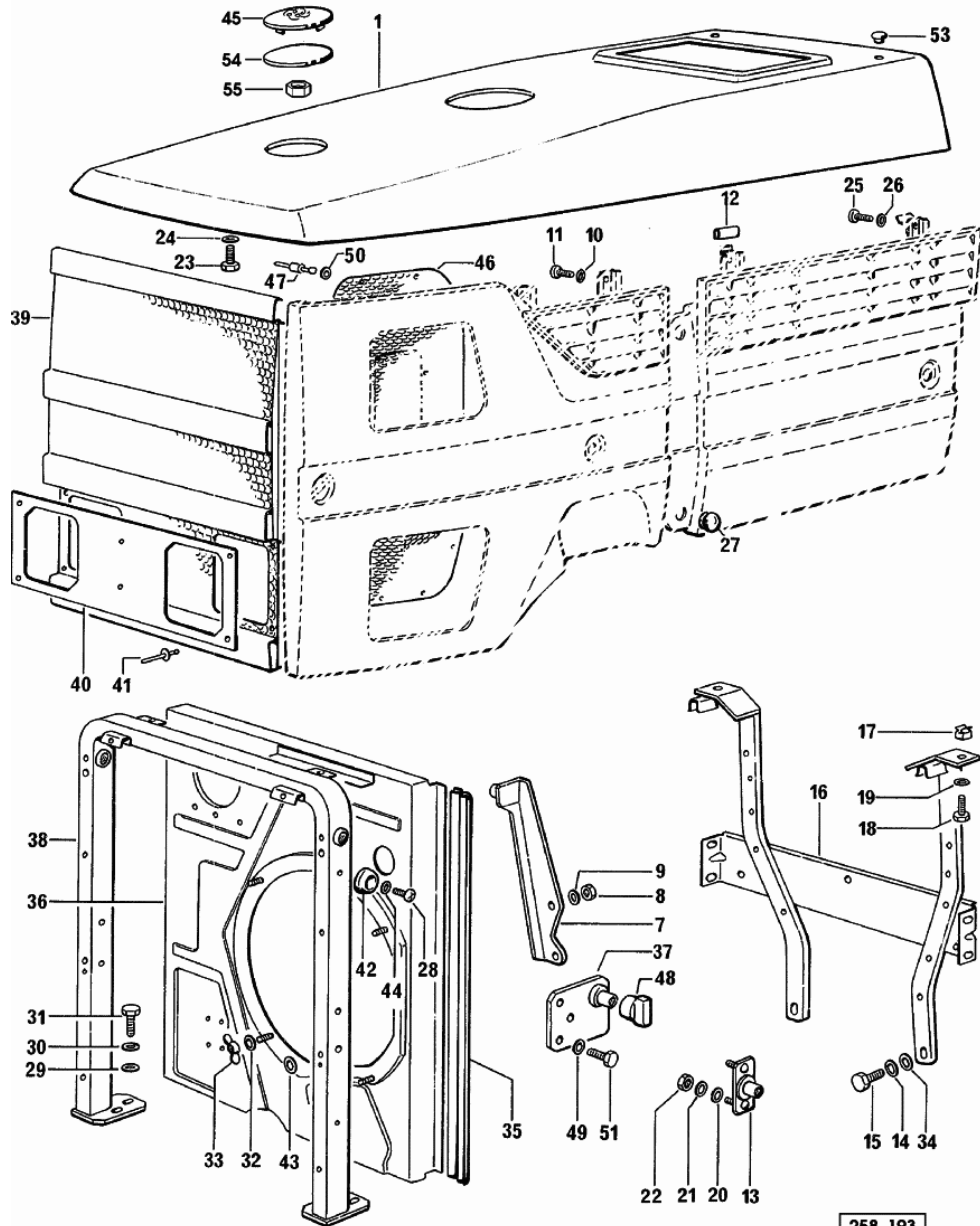
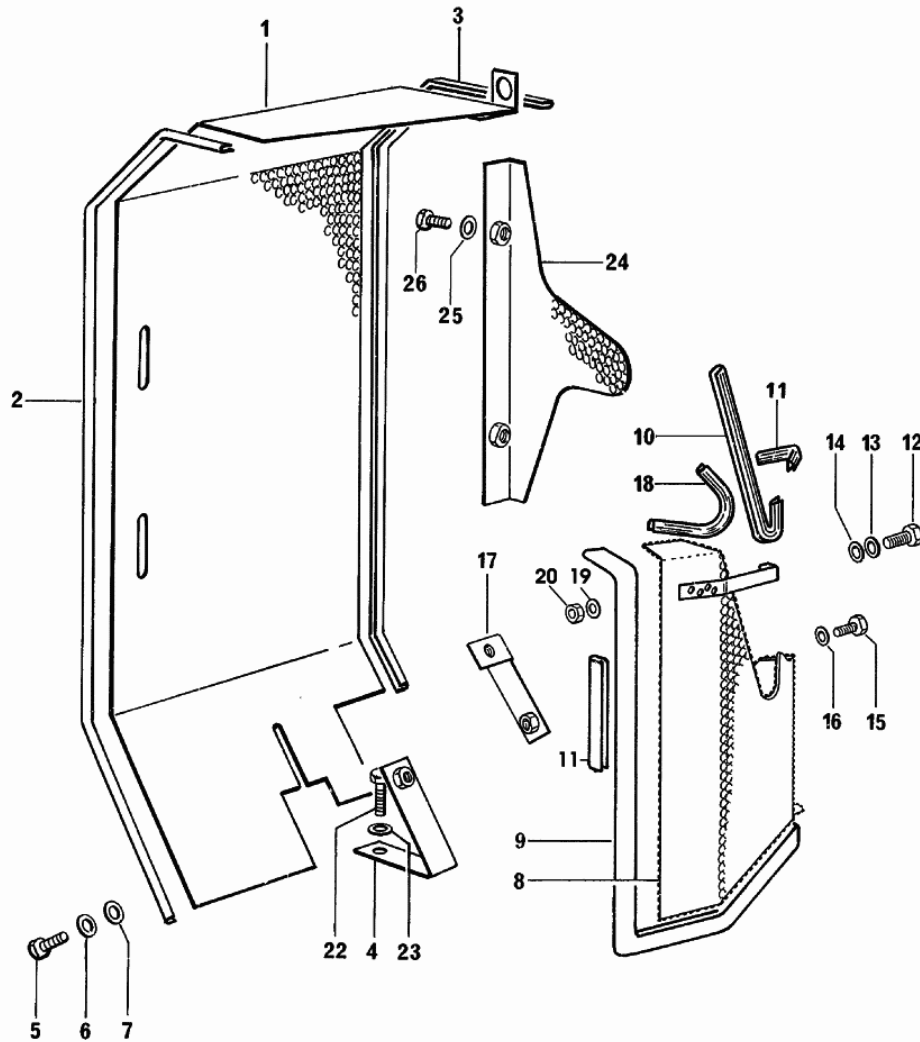

Fig.	Code	QTY	Name
1	0.258.7210.3/30	1	bonnet
1	0.258.7252.3/20	1	upper hood
			- IN TYPES WITH CAB
7	0.264.7266.3	1	bracket
8	2.1011.105.2	2	nut m 8 p.1.25
9	2.1470.004.2	2	washer 8
10	2.1312.002.2	8	washer 5
11	2.0350.455.2	8	screw 4.2x16
12	0.98503.69.0	2	guard
13	0.264.7270.3/10	2	small plate
14	2.1470.007.2	2	lock washer 12
15	2.0112.413.2	2	screw m 12 p.1.75x35
16	0.257.7276.2/40	1	chassis frame
17	2.6999.008.2	2	special nut m 8 p.1.25
18	2.0112.207.2	2	screw m 8 p 1.25 x 20
19	2.1470.004.2	2	washer 8
20	2.1310.004.2	4	flat washer 8.5
21	2.1470.004.2	4	washer 8
22	2.1011.105.2	4	nut m 8 p.1.25
23	2.0112.307.2	4	screw m 10 p.1.5 x 20
24	2.1470.006.2	4	lock washer 10
25	2.0350.455.2	8	screw 4.2x16
26	2.1312.002.2	8	washer 5
27	0.264.7265.0/20	4	plug
28	2.0350.406.2	4	screw m 4.2 x 19 -AB-
29	2.1310.006.2	8	flat washer 10.5
30	2.1470.006.2	8	lock washer 10
31	2.0112.311.2	8	screw m 10 p.1.5 x 30
32	2.1312.003.2	4	washer 6
33	2.1110.004.2	4	wing nut m 6
34	2.1310.007.2	2	flat washer 13.5
35	0.264.7261.0	2	gasket
36	0.264.7233.3/10	1	division
			1384 <- X 110HP
			1160 <- X 130HP
36	0.257.7270.3/70	1	division
			-> 1385 X 110HP
			-> 1161 X 130HP
37	0.264.7268.3/20	1	bracket
38	0.264.7242.3	1	chassis frame
39	0.264.7215.2/40	1	front grille

258_193

Section: BODY WORK
HOOD - GUARDS

Fig.	Code	QTY	Name
1	0.269.7282.2	1	shield
2	0.444.7291.0	1	gasket
3	0.269.7284.0	1	gasket
4	0.273.7265.2	1	bracket
5	2.0112.205.2	1	screw m 8 p.1.25 x 16
6	2.1470.004.2	1	washer 8
7	2.1310.004.2	1	flat washer 8.5
8	0.258.7260.2/40	1	shield
9	0.212.7271.0/30	1	gasket
10	0.238.7684.0	1	gasket
11	0.226.7270.0	2	gasket
12	2.0112.219.2	1	screw m 8 p.1.25x50
13	2.1470.004.2	1	washer 8
14	2.1310.004.2	1	flat washer 8.5
15	2.0112.205.2	1	screw m 8 p.1.25 x 16
16	2.1310.004.2	1	flat washer 8.5
17	0.273.7266.2	1	bracket
18	0.212.7281.0	1	gasket mm 170
19	2.1470.004.2	1	washer 8
20	2.1011.105.2	1	nut m 8 p.1.25
22	2.0112.305.2	1	screw m 10 p.1.5 x 16
23	2.1470.006.2	1	lock washer 10
24	0.269.7285.2	1	shield
25	2.1310.002.3	2	flat washer 6.4 x 12 x 1.6
26	2.0112.005.2	2	screw m 6 p.1 x 16



Section: BODY WORK
PLATFORM

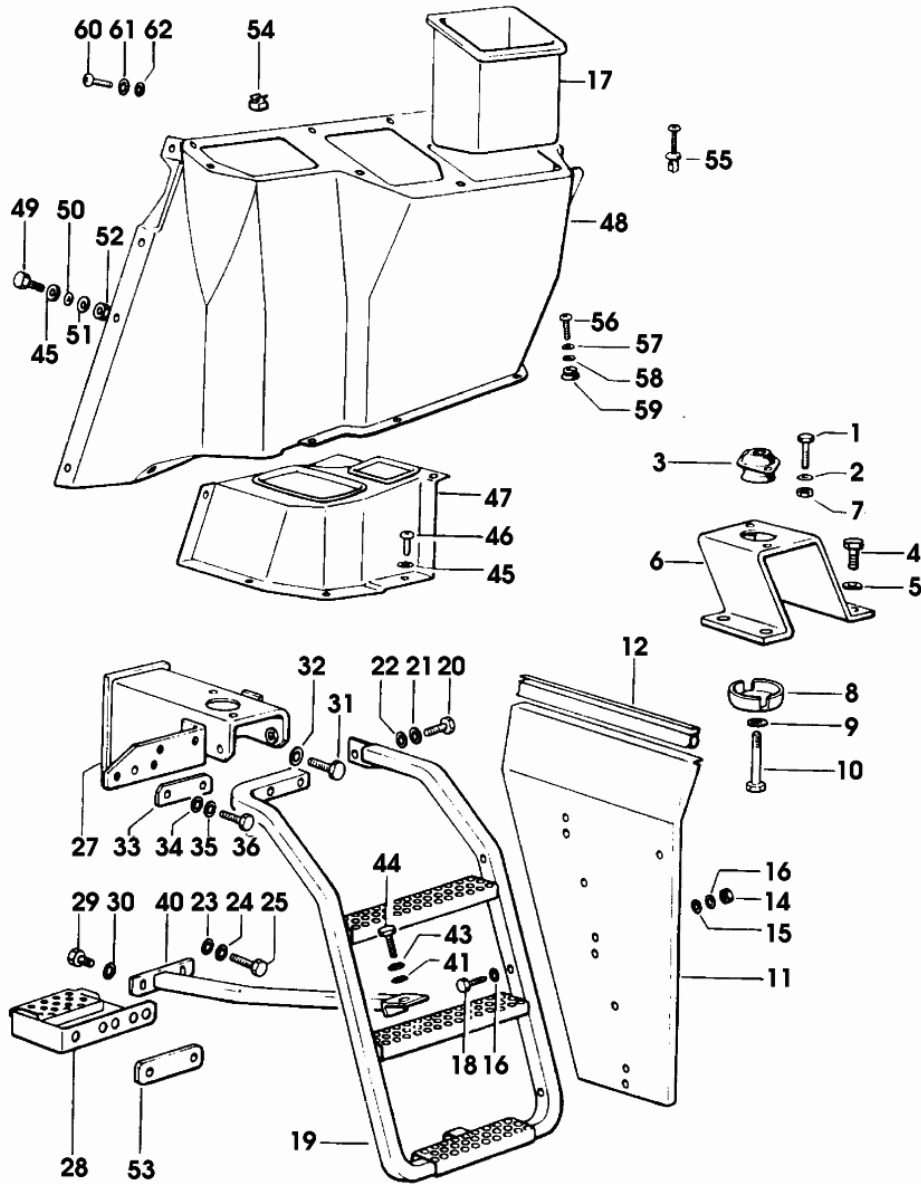
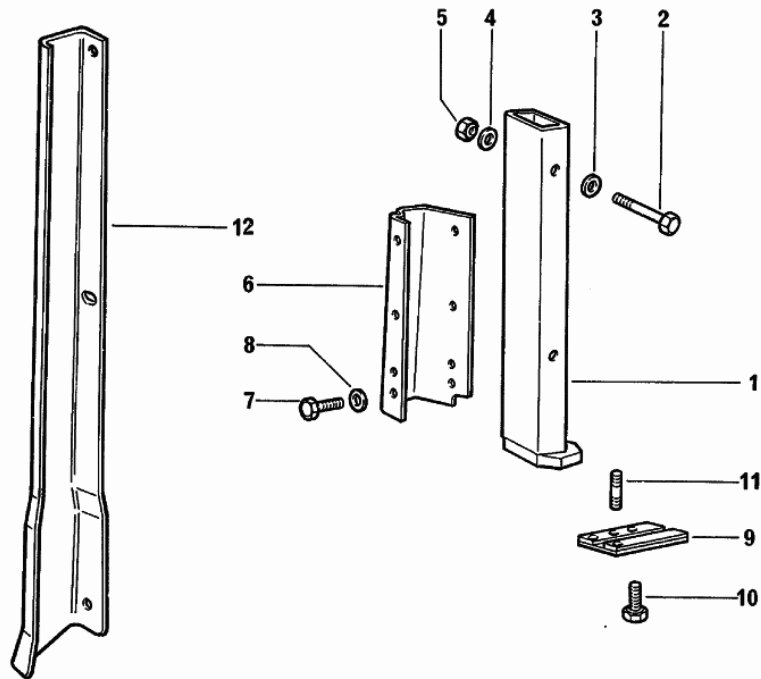

Fig.	Code	QTY	Name
1	2.0112.309.2	8	screw m 10 p.1.5 x 25
2	2.1470.006.2	8	lock washer 10
3	0.169.7686.0	4	silent-block
4	2.0112.613.2	8	screw m 16 p.2x35
5	2.1470.009.2	8	lock washer 16
6	0.258.7637.0/20	2	support - X 130HP
6	0.264.7637.0/10	2	support - X 150HP
7	2.1011.106.2	8	nut m 10 p.1.5
8	0.257.7650.2	4	spacer - X 130HP
8	0.264.7665.2	4	spacer - X 150HP
9	2.1470.009.2	4	lock washer 16
10	2.0122.623.2	4	screw m 16 p.1.5x70
11	0.264.7666.0/30	1	guard dx/rh/re
11	0.264.7667.0/30	1	guard sx/lh/li
12	0.269.7660.0	2	gasket
14	2.1011.105.2	1	nut m 8 p.1.25
15	2.1312.004.3	6	washer 8,4x24x2
16	2.1470.004.2	12	washer 8
17	0.257.7656.0/10	1	glove pocket
18	2.0112.215.2	6	screw m 8 p.1.25 x 40
19	0.264.7642.3/30	1	climbing steps dx/rh/re
19	0.264.7643.3/30	1	climbing steps sx/lh/li
20	2.0112.311.2	2	screw m 10 p.1.5 x 30 - X 130HP
20	2.0112.313.2	4	screw m 10 p.1.5 x 35 - X 130HP
20	2.0112.319.2	4	screw m 10 p.1.5 x 50
21	2.1470.006.2	6	lock washer 10
22	2.1310.006.2	6	flat washer 10.5
23	2.1310.006.2	4	flat washer 10.5
24	2.1470.006.2	4	lock washer 10
25	2.0112.311.2	4	screw m 10 p.1.5 x 30
27	0.258.7635.2	1	support dx/rh/re - X 130HP
27	0.258.7636.2	1	support sx/lh/li - X 130HP
27	0.264.7635.2/10	1	support dx/rh/re - X 150HP
27	0.264.7636.2/10	1	support sx/lh/li - X 150HP

258_229

REINFORCEMENTS FOR EXPORT F

Fig.	Code	QTY	Name
1	0.9233.175.3	1	brace dx/rh/re
1	0.9233.177.3	1	brace sx/lh/li
2	2.0112.327.2	4	screw m 10 p.1.5 x 90
3	2.1310.006.2	4	flat washer 10.5
4	2.1470.006.2	4	lock washer 10
5	2.1011.106.2	4	nut m 10 p.1.5
6	0.9233.173.2	1	plate dx/rh/re
6	0.9233.174.2	1	plate sx/lh/li
7	2.0112.205.2	12	screw m 8 p.1.25 x 16
8	2.1470.004.2	12	washer 8
9	0.258.7667.3	1	brace dx/rh/re
9	0.258.7670.3	1	brace sx/lh/li
10	2.0112.515.6	2	screw m 14 p.2 x 40
11	2.0422.511.7	4	stud bolt m14 x 40
12	0.9233.357.0/20	1	cover dx/rh/re
12	0.9233.358.0/20	1	cover sx/lh/li



258_235

Section: BODY WORK
SEAT

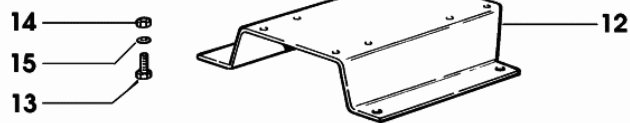
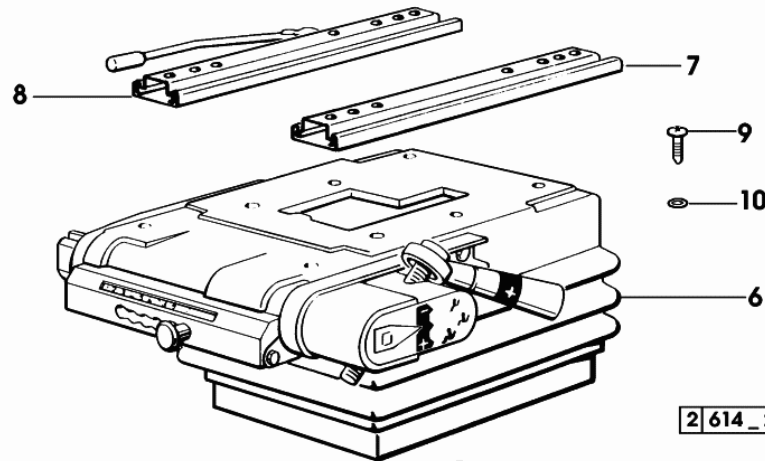
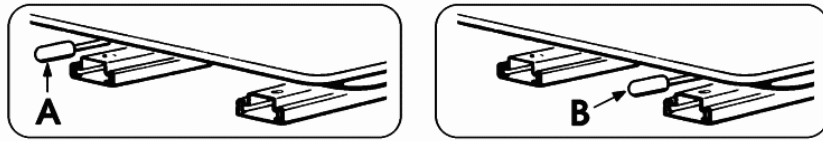
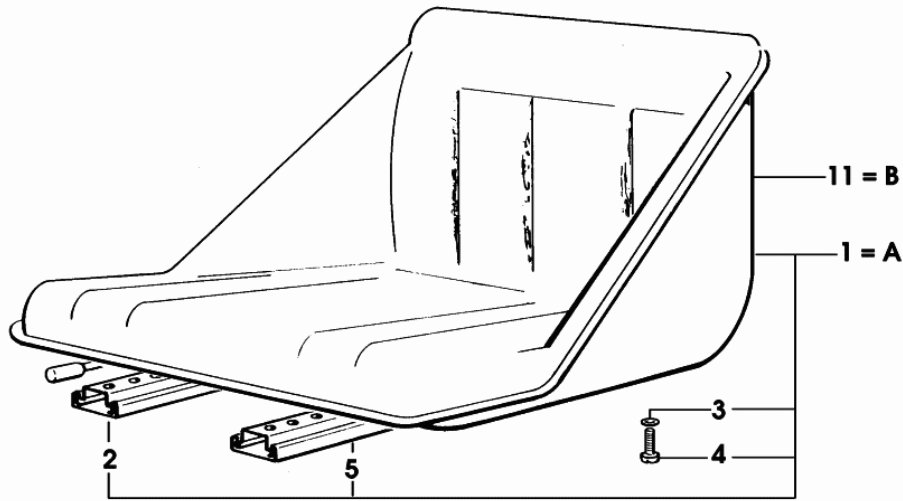
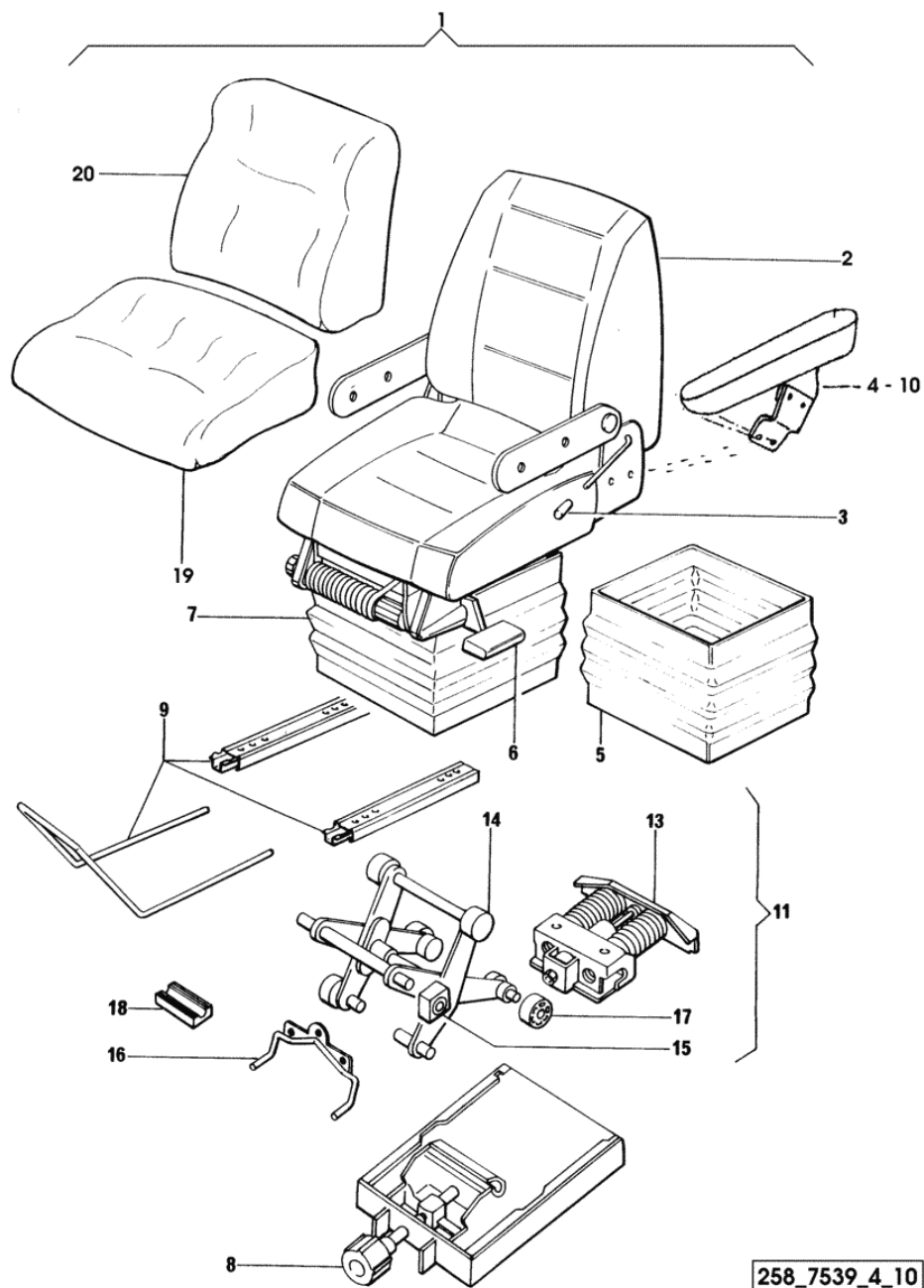

Fig.	Code	QTY	Name
Notes:			
-> (...)			
1	0.154.7524.4/20	1	seat (...) <- = A
1	0.269.7524.4	1	seat (...) <- = A - IN FABRIC
2	0.201.7550.3	1	seat guide dx/rh/re
3	2.1470.004.2	4	washer 8
4	2.0312.206.2	4	screw m 8 p 1.25 x 20
5	0.201.7551.3	1	seat guide sx/lh/li
6	0.164.7534.4/20	1	seat springs F 255/2 (...) <- X A - FOR PREVIOUS VERSION-SEE REF.255/1 ☞ 0.164.7534.4/20 ☞ 07.00.70
6	0.010.5356.4	1	seat springs KAB XH2 F 257 -> (...) X B - FOR PREVIOUS VERSION-SEE REF.255/1 ☞ 0.010.5356.4 ☞ 0.164.7534.4/20 ☞ 07.00.70
7	0.201.7551.3	1	seat guide sx/lh/li
8	0.201.7550.3	1	seat guide dx/rh/re
9	2.0332.406.2	4	screw m 6 p.1.0 x 16
10	2.1310.002.2	4	washer 6.6, d125
11	0.010.5358.4	1	seat -> (...) = B
12	0.264.7536.0/10	1	plate
13	2.0119.164.3	4	screw m 8 p.1.25 x 20
14	2.1011.105.2	4	nut m 8 p.1.25
15	2.1499.096.3	4	washer 8

Section: BODY WORK
SEAT-COMPONENTS

Fig.	Code	QTY	Name
1	0.258.7539.4/10	1	sprung seat ☞ 0.258.7539.4/10
2	0.258.7552.1	1	cushion
3	0.177.7565.0	1	handle
4	0.009.4474.0	1	small arm dx/rh/re
5	0.264.7556.1	1	guard
6	0.264.7557.1	1	knob
7	0.264.7559.1	1	seat springs
8	0.243.7553.0	1	knob
9	0.264.7560.1	1	guide
10	0.009.4473.2	1	small arm sx/lh/li
11	0.264.7555.1	1	spring
13	0.264.7563.1	1	spring
14	0.264.7564.1	1	arm
15	0.174.7570.0	4	small block
16	0.264.7565.1	1	pointer
17	0.243.7554.0	6	roller
18	0.264.7561.1	1	grip
19	0.009.4473.1	1	cover
20	0.009.4473.0	1	cover



258_7539_4_10

Section: CAB
GLASSES AND SEALS

Fig.	Code	QTY	Name
------	------	-----	------

Notes:

- IN MODELS WITH OPENABLE REAR WINDOW, WITH 7 HOLES

1	0.9234.210.0/30	1	stratified glass
2	0.9234.211.0/30	2	stratified glass
3	0.9234.230.0	1	gasket
4	0.9234.250.0	2	gasket
5	0.9234.255.0	1	gasket
6	0.9234.268.3	1	chassis frame
7	2.6569.019.0	7	rubber plug
8	2.1579.826.2	7	spacer 9x14x17
9	2.1599.495.2	5	washer 8.5
10	2.1474.009.2	5	spring washer 8
11	2.0112.215.2	4	screw m 8 p.1.25 x 40
12	0.9234.276.0	5	cap
13	0.9234.274.0/10	2	hinge
14	2.0332.510.2	2	screw m 8 x 35
15	0.9231.266.0/10	2	hinge
16	2.0342.307.2	4	screw m 8 p.1.25 x 25
17	2.1699.221.2	2	pin 8x90 * 2306 <- X 100HP * 2724 <- X 110HP * 1990 <- X 130HP * 1559 <- X 150HP - N.2 2.1630.210.0
18	2.1430.007.7	4	circlip 6, d128 2306 <- X 100HP 2724 <- X 110HP 1990 <- X 130HP 1559 <- X 150HP
19	0.9234.273.0	1	bronzed glass
20	0.9234.254.0	1	gasket
21	0.9234.216.0/20	1	bronzed glass
22	0.9234.242.0/10	1	gasket
23	0.9234.246.0/10	1	profile
24	0.9234.267.0	1	gasket
25	2.1630.210.2	2	roll pin 3 x 20 -> 2307 X 100HP -> 2725 X 110HP -> 1991 X 130HP -> 1560 X 150HP
26	2.1312.004.2	2	washer 8.4
32	2.1699.216.2	2	pin (...)<

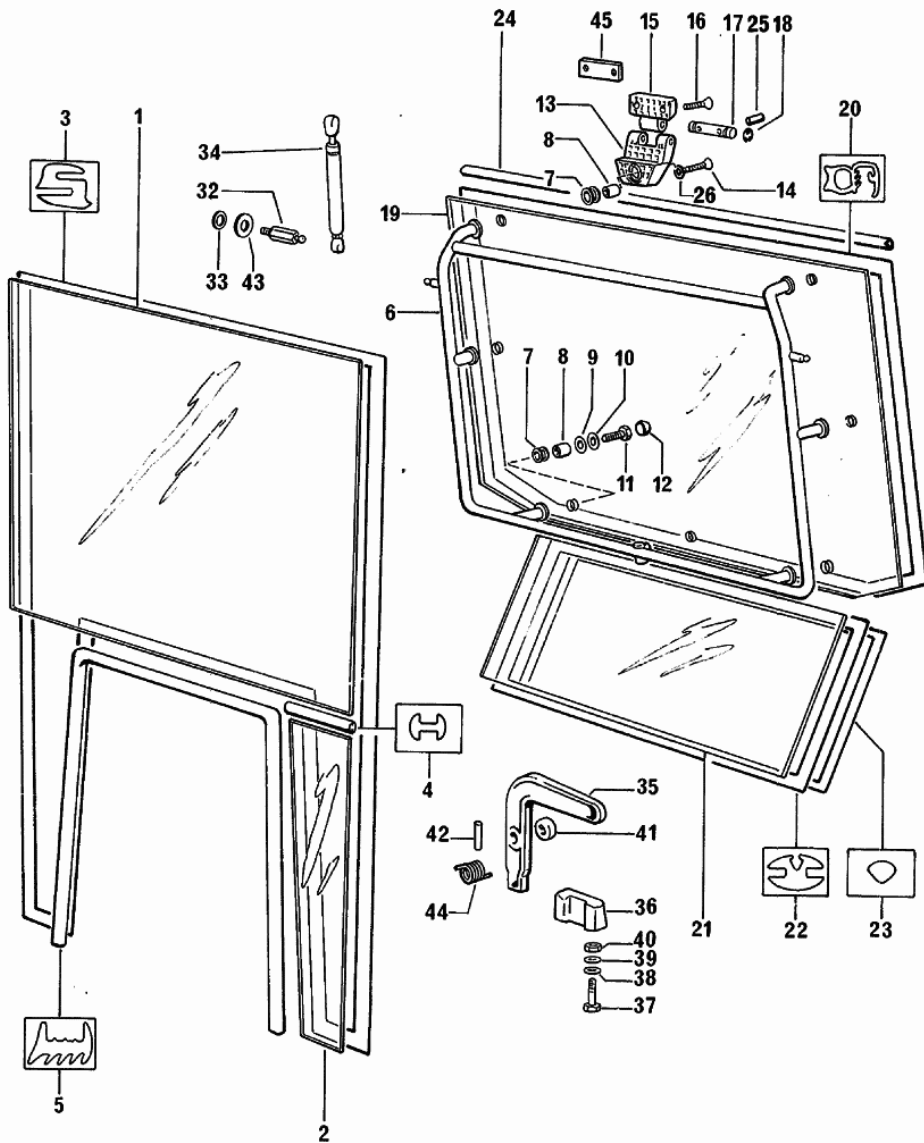

258_299

Section: CAB

INTERIOR TRIM FOR UNDER ROOF POSITIONED HEATING-SYSTEM TYPES

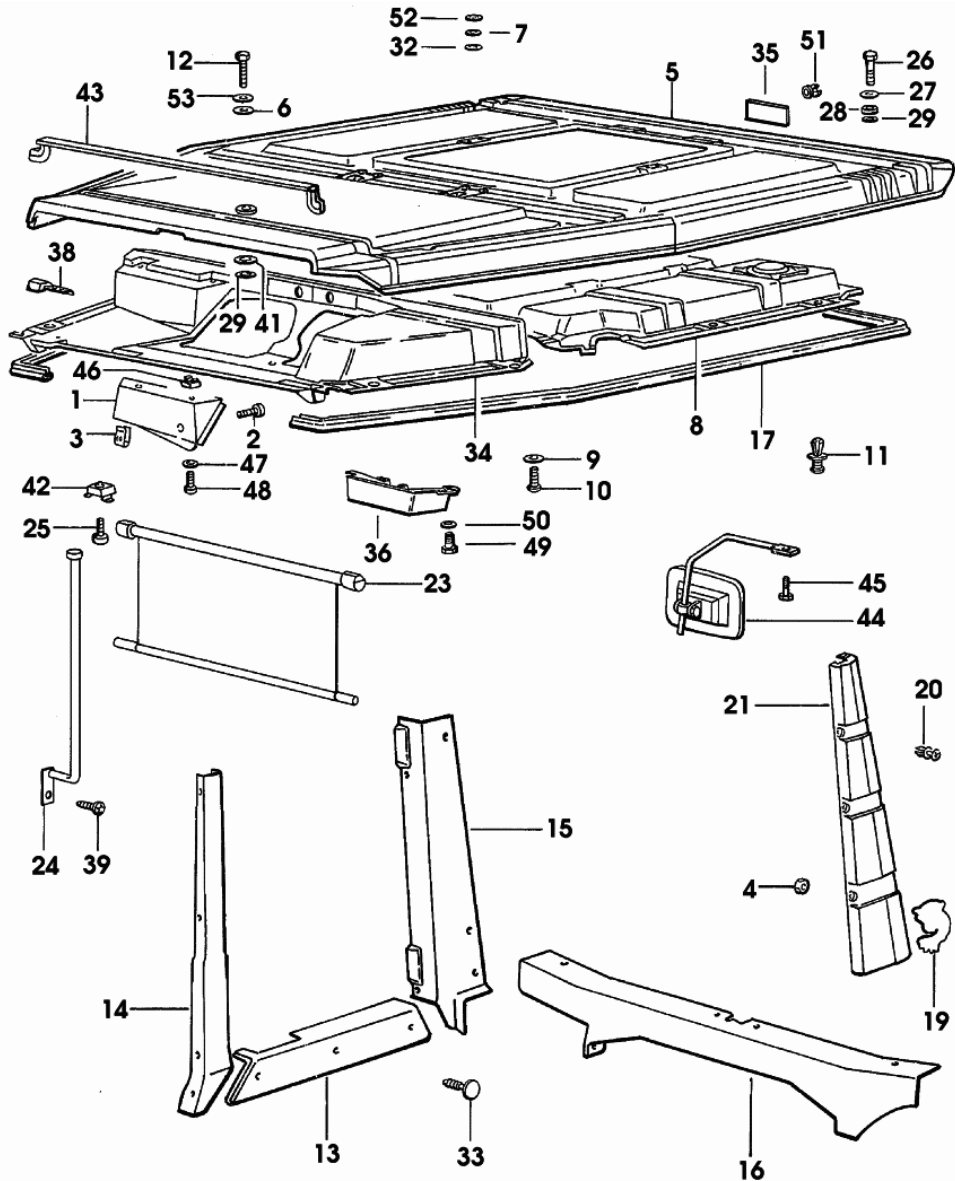
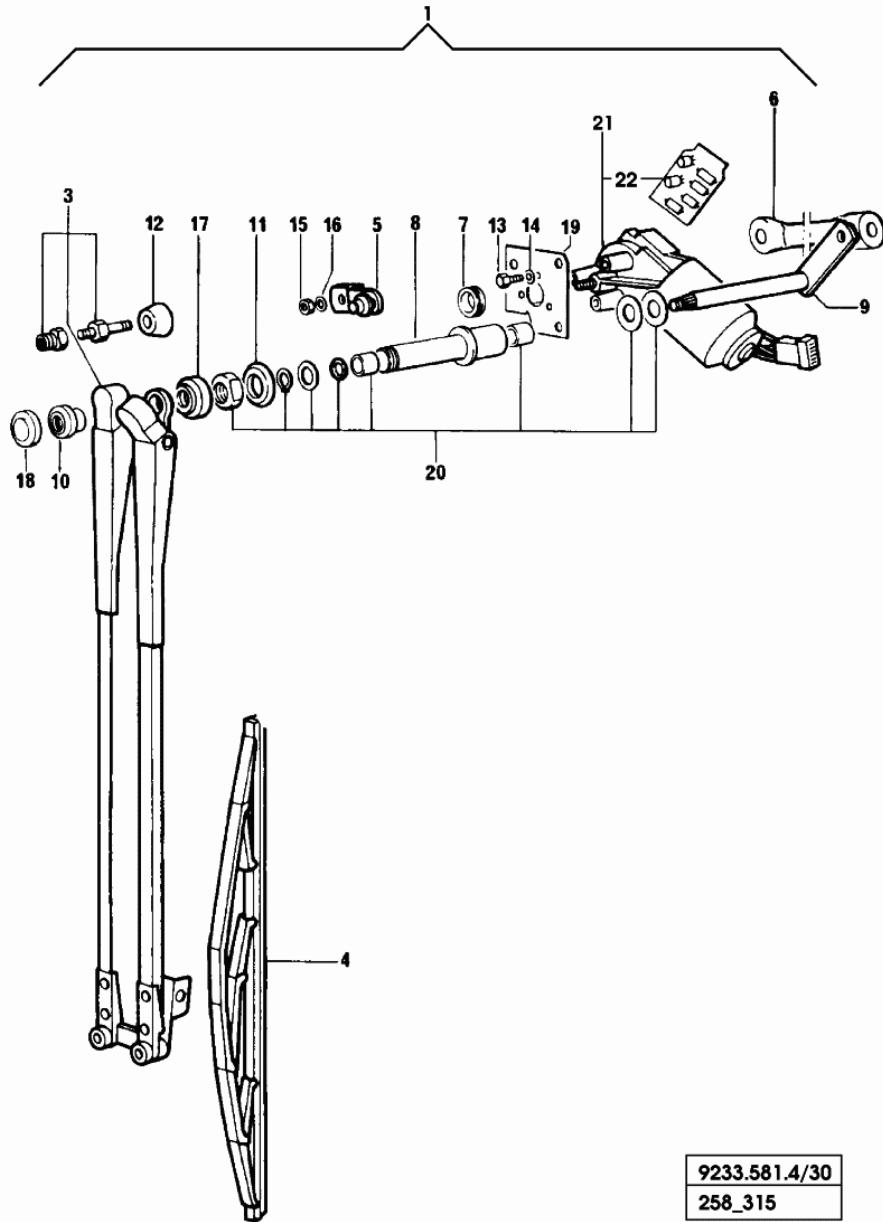

Fig.	Code	QTY	Name
1	0.9233.385.0/20	1	front grille (...) <-
1	0.9233.385.0/30	1	front grille -> (...)
2	2.0351.456.2	2	screw m 4.2 x 19 -AB-
3	2.6999.061.0	2	small spring 4.2
4	2.1129.004.0	4	selflock nut m 4
5	0.9233.178.3/10	1	roof
6	2.1312.006.2	1	washer 14.5
7	2.1579.846.0/10	1	spacer 12.5x40x2
8	0.9233.310.0	1	inner cab roof panel
9	0.9200.358.0	8	washer 5.4x10x15.8
10	2.0350.555.6	4	screw 4.8x16
10	2.0350.506.2	4	screw 4.8x19
11	2.1899.061.0	44	rivet
12	2.0112.209.2	4	screw m 8 p 1.25 x 25
13	0.9233.363.0/10	1	cover dx/rh/re
14	0.9233.379.0	1	guard dx/rh/re
14	0.9233.380.0	1	guard sx/lh/li
15	0.9233.359.0/20	1	cover dx/rh/re
15	0.9233.360.0/20	1	cover sx/lh/li
16	0.9233.366.0/20	1	cover
17	0.9237.354.0	1	gasket
19	0.264.7227.2	2	plate
20	2.1899.058.0	12	rivet 8 x 21
21	0.9234.363.0	1	cover dx/rh/re
21	0.9234.364.0	1	cover sx/lh/li
23	0.9237.343.4/10	1	roll-up sun-shade
24	0.9237.357.4	2	rod
25	2.0220.209.2	2	screw m 4x0.7x14
26	2.0112.411.2	4	screw m 12 p.1.75 x 30
27	2.1470.007.2	4	lock washer 12
28	2.1579.582.2	3	spacer 14.5 x 28 x 4
29	2.1311.012.2	3	flat washer 20
32	2.1579.847.0/10	1	spacer 20.5x40x2
33	2.3199.133.0	2	plug 11
34	0.9233.381.0/20	1	inner cab roof panel
35	0.9234.193.2	1	plate
36	0.9237.355.0	1	terminal dx/rh/re
36	0.9237.356.0	1	terminal sx/lh/li
38	0.9231.379.2	1	stopper dx/rh/re
38	0.9231.380.2	1	stopper sx/lh/li
39	2.0350.454.2	2	screw 4.2x13
41	2.1579.847.0/10	1	spacer 20.5x40x2

258_306

WINDSCREEN WIPER PARTS

Fig.	Code	QTY	Name
1	0.9233.581.4/30	1	windscreen wiper ☞ 0.9233.581.4/30
3	0.9233.575.3/10	1	arm
4	0.9233.585.3	1	wiper blade
5	0.9233.578.2	1	crank
6	0.9233.577.2	1	connecting rod
7	2.6569.022.0	1	rubber plug 18
8	0.9233.579.2/10	1	sleeve
9	0.9233.580.3	1	pin
10	0.9233.586.1	1	nut
11	0.9233.574.0	1	spacer
12	0.9233.573.0	1	spacer
13	2.0112.005.2	3	screw m 6 p.1 x 16
14	2.1472.003.2	3	washer 6, d128
15	2.1011.103.2	1	nut m 6 p.1
16	2.1472.003.2	1	washer 6, d128
17	0.9233.587.1	1	cap
18	0.9233.588.1	1	cap
19	0.9233.572.2	2	plate
20	0.000.0000.1	0	not serviceable
21	2.9019.070.0/10	1	wiper motor
22	0.010.2222.0	1	intermitent switch



Section: CAB

**VENTILATION AIR CONDITIONING FOR UNDER BONNET POSITIONED
AIR-CONDIT.SYSTEM TYP.**

Fig.	Code	QTY	Name
			-> (...)
10	0.98537.65.4	1	clamp
12	2.0112.005.2	4	screw m 6 p.1 x 16
13	2.1470.002.2	4	washer 6, d128
14	2.1310.002.3	4	flat washer 6.4 x 12 x 1.6
15	0.98570.61.4	1	rotor blade
17	0.98570.21.3/10	1	condenser 2226 <- X 100HP 2659 <- X 110HP 1990 <- X 130HP 1559 <- X 150HP
17	0.98570.21.3/20	1	condenser -> 2227 X 100HP -> 2660 X 110HP -> 1991 X 130HP -> 1560 X 150HP
18	2.0112.005.2	4	screw m 6 p.1 x 16
19	2.1470.002.2	4	washer 6, d128
20	2.0112.209.2	2	screw m 8 p 1.25 x 25
21	2.1470.004.2	2	washer 8
22	2.1599.006.2	8	snoulder 8.4x25x2
23	0.021.1560.0	8	rubber plug
24	2.1579.764.2	4	spacer
25	0.98535.75.0/30	2	bracket
26	0.98535.63.0/10	2	bracket
27	2.0112.211.2	2	screw m 8 p.1.25 x 30
28	2.1470.004.2	2	washer 8
29	2.0112.202.2	4	screw m 8 p.1.25 x 10
30	2.1470.004.2	4	washer 8
31	0.98570.51.0	2	bracket
32	2.1011.105.2	2	nut m 8 p.1.25
33	0.98503.59.0	8	small spring
34	0.98581.52.3	1	tube - X 100HP
34	0.98560.34.3	1	tube - X 110HP - X 130HP
34	0.98544.34.3/10	1	tube - X 150HP
35	0.98544.32.3	1	tube 1384 <- X 110HP 1160 <- X 130HP

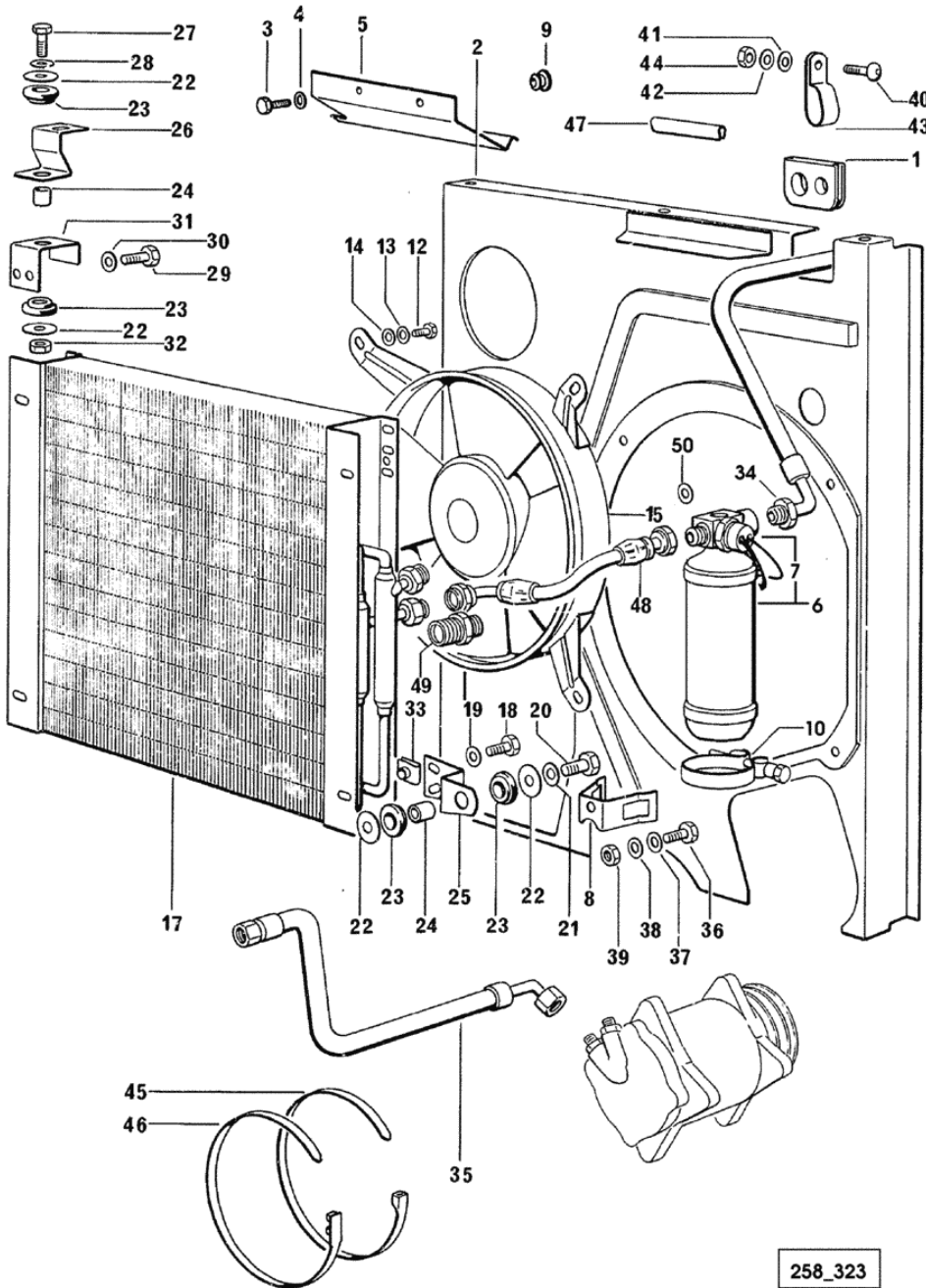

258_323

Section: CAB

**VENTILATION-HEATING-AIR CONDITIONING FOR UNDER-BONNET POS.
AIR-COND. SYSTEM**

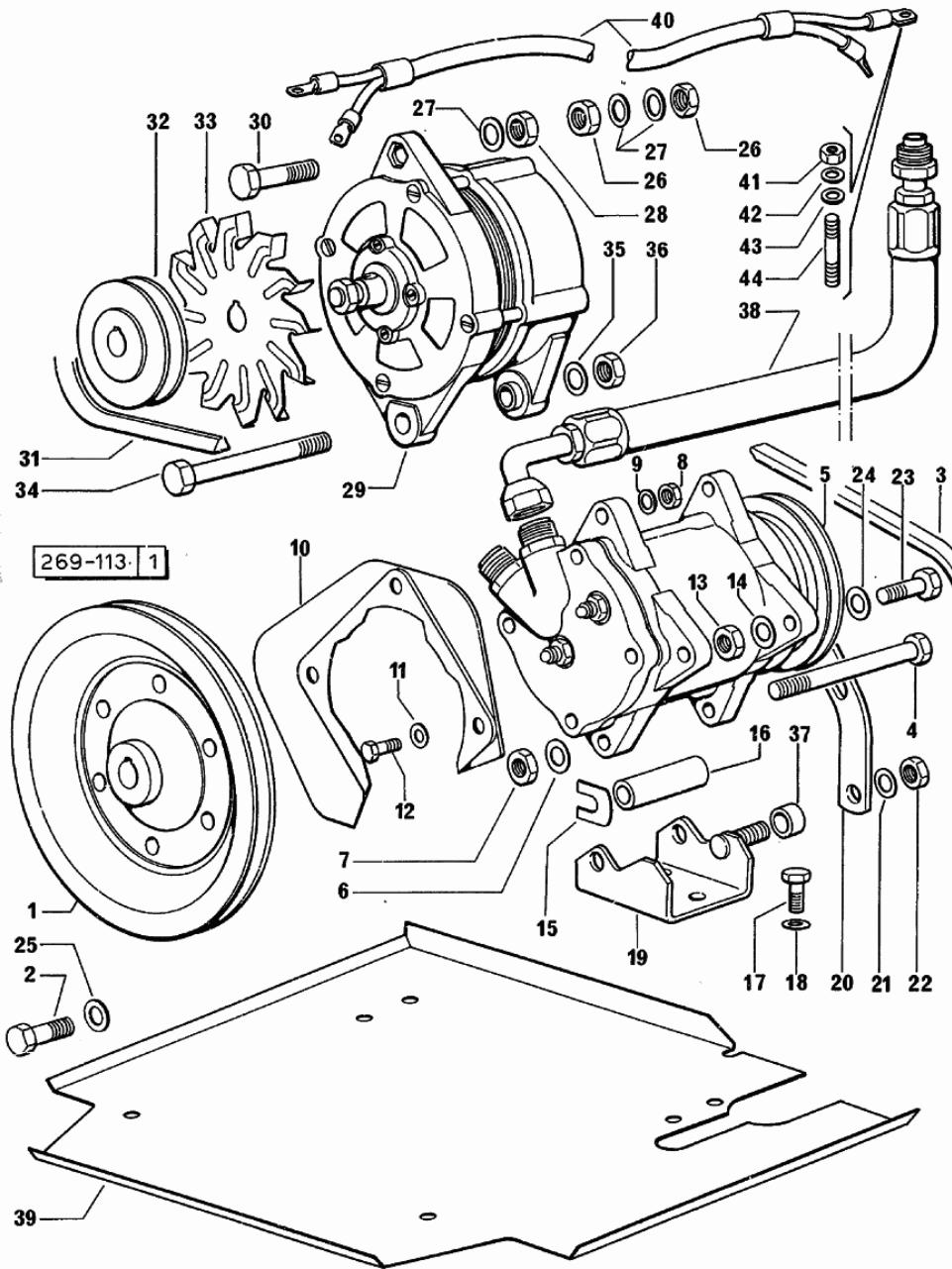

Fig.	Code	QTY	Name
15	0.167.8462.0	3	small plate mm 2.00
16	2.1579.760.2	1	spacer
17	2.0112.309.2	3	screw m 10 p.1.5 x 25
18	2.1470.006.2	3	lock washer 10
19	0.98535.65.2/10	1	bracket 1384 <- X 110HP 1160 <- X 130HP 1098 <- X 150HP
19	0.98535.84.2/10	1	bracket <- X 100HP >- 1385 X 110HP >- 1161 X 130HP >- 1099 X 150HP
20	0.98535.64.0/10	1	rod 1390 <- X 100HP 1974 <- X 110HP 1445 <- X 130HP 1199 <- X 150HP
20	0.98535.86.0	1	rod >- 1391 X 100HP >- 1975 X 110HP >- 1446 X 130HP >- 1200 X 150HP
21	2.1470.006.2	1	lock washer 10
22	2.1011.321.2	1	nut m 10 p.1.25
23	2.0112.313.2	1	screw m 10 p.1.5 x 35
24	2.1310.006.2	1	flat washer 10.5
25	2.1474.011.2	6	spring washer 12
26	2.1011.521.2	2	nut m 10 p.1.25
27	2.1310.006.2	3	flat washer 10.5
28	2.1011.321.2	1	nut m 10 p.1.25
29	2.9439.190.0	1	alternator 55 A F 328 ☞ 2.9439.190.0 ☞ 0B.00.34
29	2.9439.480.0	1	alternator 65A MARELLI F 329 ☞ 2.9439.480.0 ☞ 0B.00.35
29	2.9439.490.0	0	alternator 65A F 329/1 ☞ 2.9439.490.0

AIR CONDITIONING FOR UNDER ROOF POSITIONED AIR-CONDITIONING SYSTEM TYPES

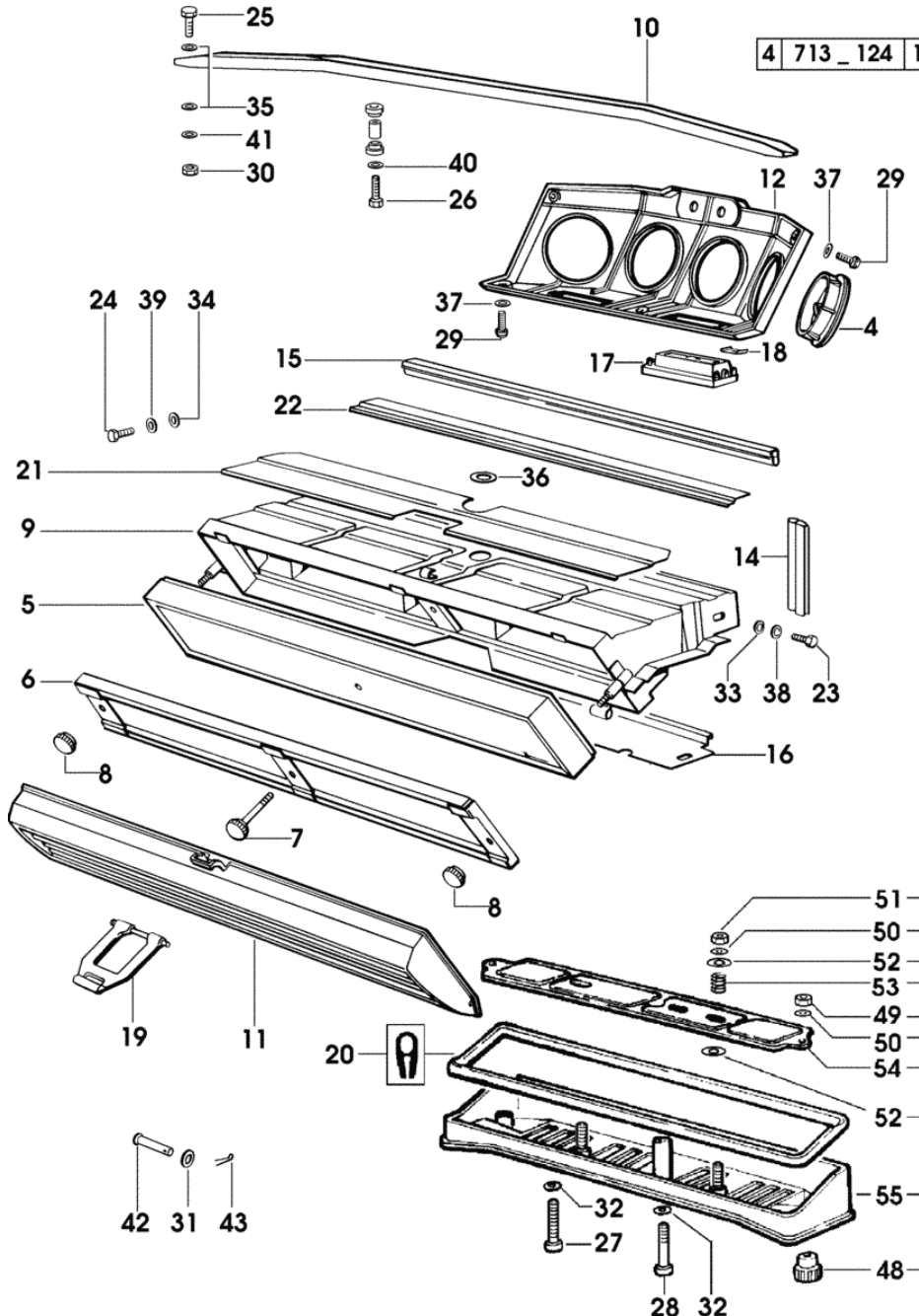

Fig.	Code	QTY	Name
4	0.98537.59.4/10	4	blower
5	0.98706.51.2	1	air filter
6	0.98706.52.2/10	1	frame
			(...) <-
7	0.98706.53.2/10	1	knob
8	0.98706.54.2/10	2	knob
9	0.98706.55.3/30	1	duct
10	0.98706.57.3	1	crosspiece
11	0.98706.69.0	1	grille
12	0.98706.70.0/10	1	front grille
14	0.98706.76.0/10	2	gasket
15	0.98706.77.0/20	1	gasket
16	0.98706.78.0/40	1	gasket
17	0.98706.83.4	2	tongue
18	0.98706.85.0	8	small spring
19	0.98706.86.4/10	1	small belt
20	0.98706.87.0	1	gasket
21	0.98706.88.0/10	1	panel
22	0.98706.89.0/10	1	panel
23	2.0112.005.2	2	screw m 6 p.1 x 16
24	2.0112.207.2	6	screw m 8 p 1.25 x 20
25	2.0112.207.2	2	screw m 8 p 1.25 x 20
26	2.0112.211.2	4	screw m 8 p.1.25 x 30
27	2.0312.116.2	1	screw m 6 p.1 x 50
28	2.0312.120.2	4	screw m 6 p.1x70
29	2.0332.307.2	5	screw m 5 p.0.8 x 20
30	2.1011.105.2	2	nut m 8 p.1.25
31	2.1310.002.3	4	flat washer 6.4 x 12 x 1.6
32	2.1310.002.3	5	flat washer 6.4 x 12 x 1.6
33	2.1310.002.3	2	flat washer 6.4 x 12 x 1.6
34	2.1310.004.2	6	flat washer 8.5
35	2.1310.004.2	4	flat washer 8.5
36	2.1311.012.2	1	flat washer 20
37	2.1312.002.2	5	washer 5
38	2.1470.002.2	2	washer 6, d128
39	2.1470.004.2	6	washer 8
40	2.1470.004.2	4	washer 8
41	2.1470.004.2	2	washer 8
42	2.1670.113.2	2	pin 6x45
43	2.1690.205.2	2	split pin 2x12
47	0.98706.72.4/20	1	grille
48	0.9030.664.0/10	3	knob

Section: CAB

**VENTILATION-AIR-CONDITIONING, FOR UNDER ROOF POSITIONED
AIR-CONDIT.SYSTEM TYPES**

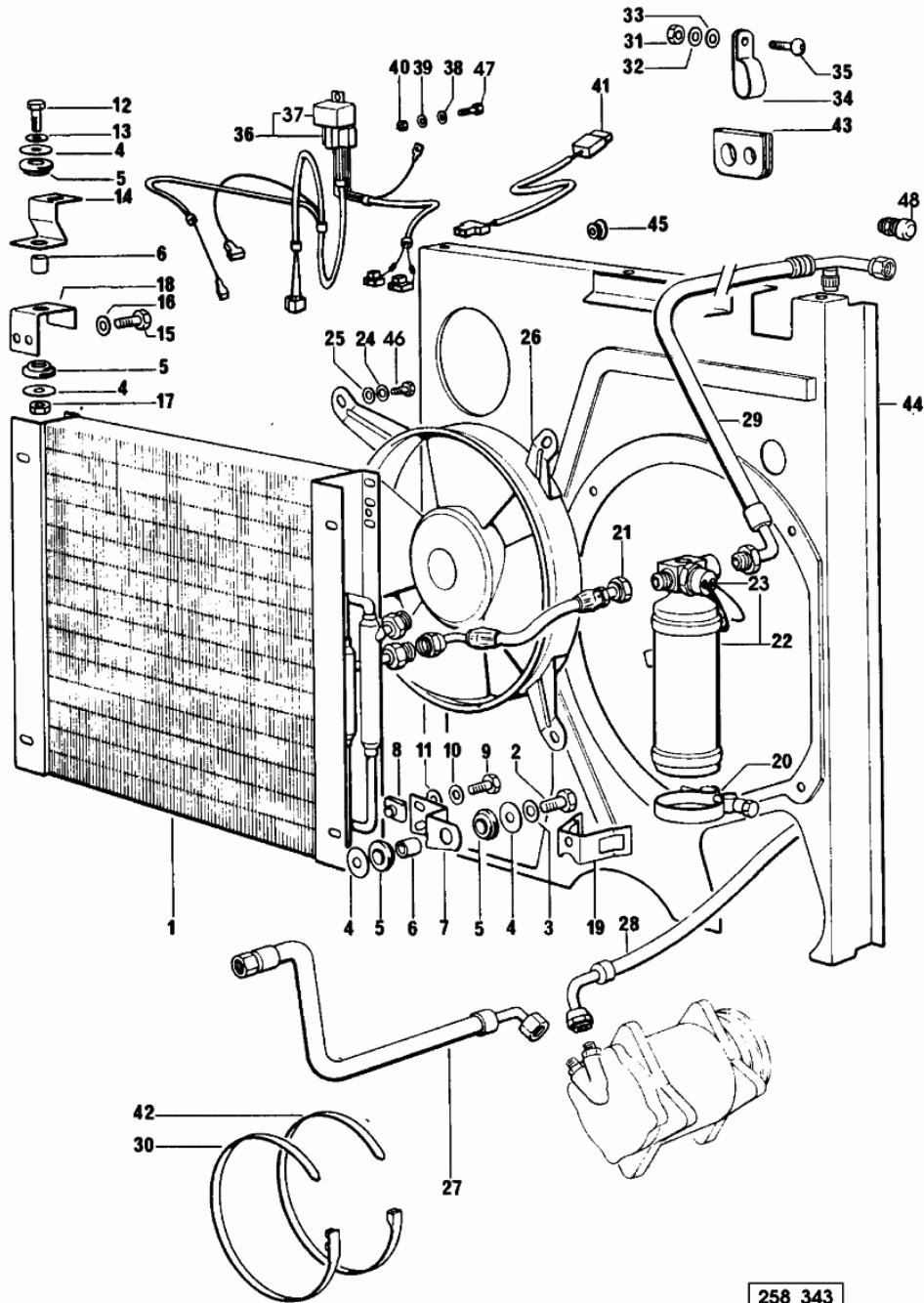

Fig.	Code	QTY	Name
			-> 3052 X 150HP
24	2.1470.002.2	4	washer 6, d128
25	2.1310.002.3	4	flat washer 6.4 x 12 x 1.6
26	0.98570.61.4	1	rotor blade
27	0.98560.51.3/10	1	tube 3702 <- X 100HP (...) <- X 110HP (...) <- X 130HP
27	0.98560.51.3/30	1	tube -> 3703 X 100HP -> (...) X 110HP -> (...) X 130HP
28	0.98717.51.3	1	tube 3702 <- X 100HP (...) <- X 110HP (...) <- X 130HP
28	0.98717.51.3/30	1	tube -> 3703 X 100HP -> (...) X 110HP -> (...) X 130HP
29	0.98717.50.3/20	1	tube
30	2.6859.030.0	1	clamp
31	2.1011.103.2	1	nut m 6 p.1
32	2.1470.002.2	1	washer 6, d128
33	2.1310.002.3	1	flat washer 6.4 x 12 x 1.6
34	2.6859.035.2/10	1	clamp
35	2.0020.103.2	1	screw m 6 p.1 x 16
36	0.98537.93.3/30	1	wire
37	2.7659.101.0	1	relay 12V-30A
38	2.1470.001.2	2	lock washer 5
39	2.1310.001.2	1	flat washer 5.3
40	2.1011.102.2	1	nut m 5 p.0.7
41	0.98712.58.3	1	wire mm 2320
42	0.98503.67.0	10	clamp
43	0.98535.62.0	1	rubber plug
44	0.257.7269.3/60	1	division 3236 <- X 100HP 3650 <- X 110HP (...) <- X 130HP
44	0.98710.80.3/10	1	division -> 3237 X 100HP -> 3651 X 110HP

258_343

CLICK HERE TO **DOWNLOAD** THE COMPLETE MANUAL

- Thank you very much for reading the preview of the manual.
- You can download the complete manual from: www.heydownloads.com by clicking the link below



- Please note: If there is no response to CLICKING the link, please download this PDF first and then click on it.

CLICK HERE TO **DOWNLOAD** THE COMPLETE MANUAL

Section: ELECTRIC AL SYSTEM
ELECTRIC LIGHTING SYSTEM

Fig.	Code	QTY	Name
------	------	-----	------

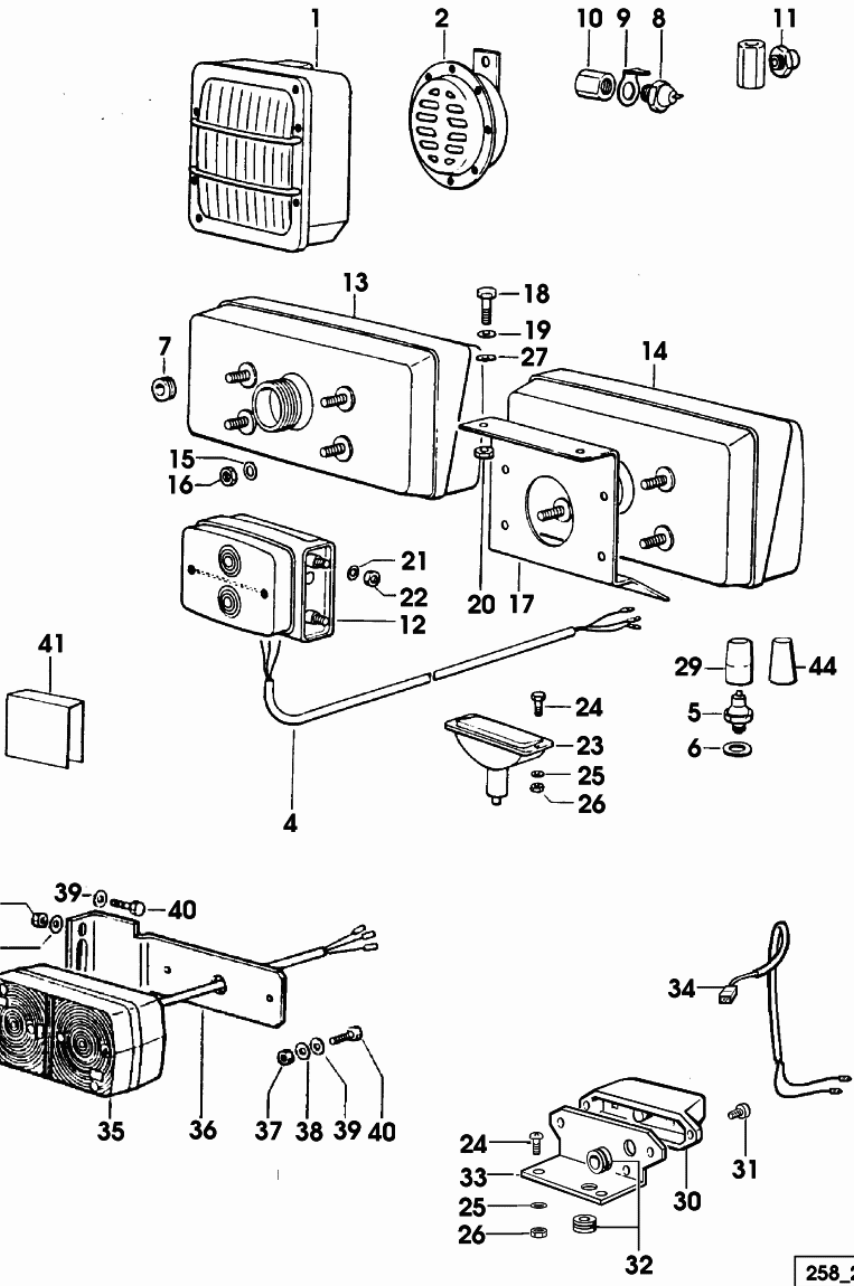

			☞ 2.8019.970.0
			☞ 2.8019.960.0
			☞ 2.8019.990.0/20
			☞ 2.8019.980.0/20
			☞ 08.00.7
13	2.8059.130.0	1	side lamp dx/rh/re - EXPORT D
			☞ 2.8029.460.0
			☞ 2.8029.670.0
			☞ 2.8029.240.0/10
			☞ 2.8019.970.0
			☞ 2.8019.960.0
			☞ 2.8019.990.0/20
			☞ 2.8019.980.0/20
			☞ 08.00.7
14	2.8019.990.0/20	1	lamp sx/lh/li F 272
			☞ 2.8029.460.0
			☞ 2.8029.670.0
			☞ 2.8029.240.0/10
			☞ 2.8019.970.0
			☞ 2.8019.960.0
			☞ 2.8019.990.0/20
			☞ 2.8019.980.0/20
			☞ 08.00.7
14	2.8059.140.0	1	side lamp sx/lh/li - EXPORT D
			☞ 2.8029.460.0
			☞ 2.8029.670.0
			☞ 2.8029.240.0/10
			☞ 2.8019.970.0
			☞ 2.8019.960.0
			☞ 2.8019.990.0/20
			☞ 2.8019.980.0/20
			☞ 08.00.7
			☞ 2.1474.007.2
			☞ 2.1011.103.2
			☞ 0.264.8550.0
			☞ 2.0099.014.0/20
			☞ 2.1470.002.2
			☞ 2.1011.103.2
			☞ 2.1011.102.2
			☞ 0.000.0000.1
		8	washer 6, d128
		8	nut m 6 p.1
		2	support
		8	screw m 6 x 25
		8	washer 6, d128
		8	nut m 6 p.1
		4	lock washer 5
		4	nut m 5 p.0.7
		0	not serviceable

258_265

Section: ELECTRIC AL SYSTEM
ELECTRIC STARTING SYSTEM

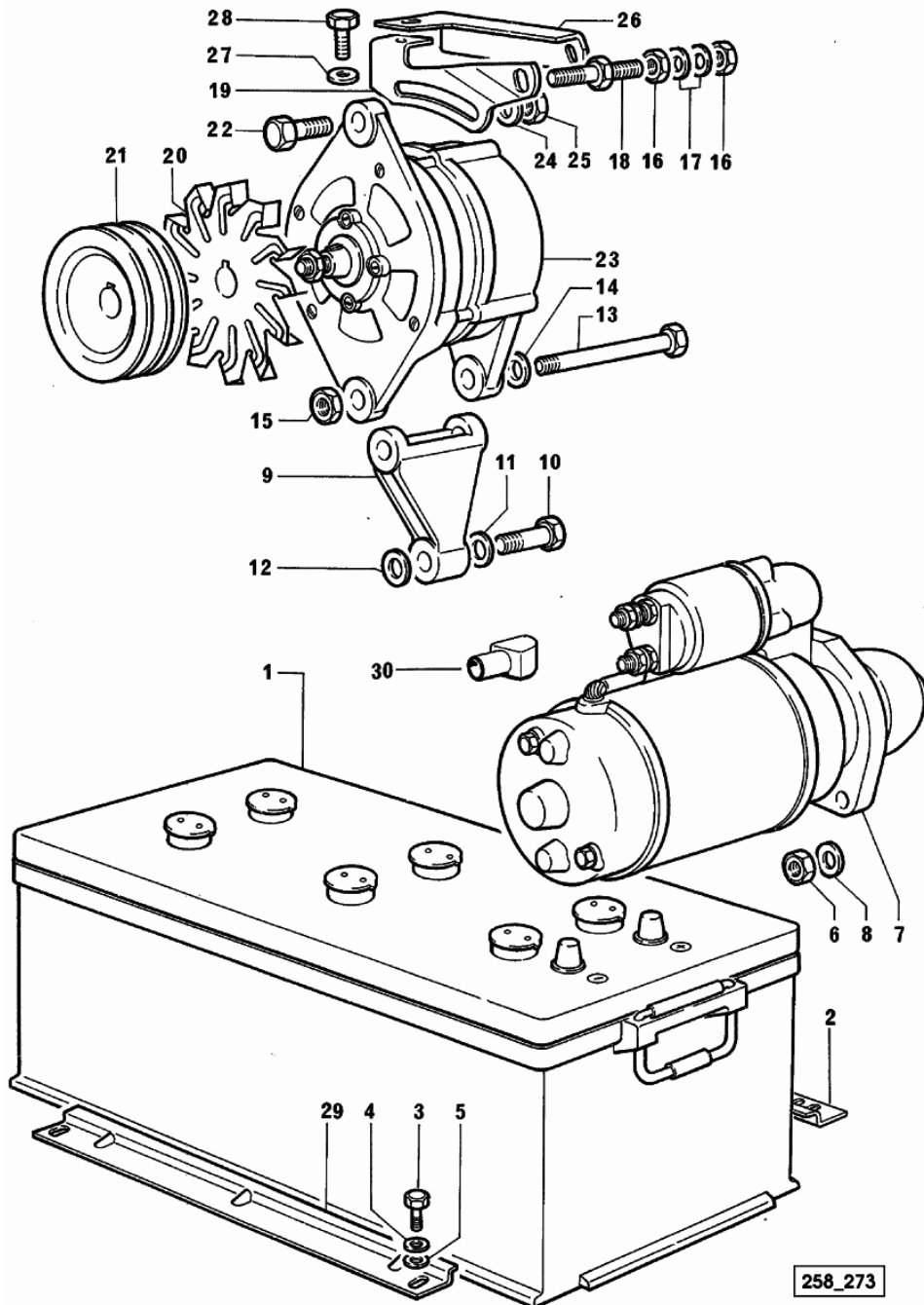

Fig.	Code	QTY	Name
18	0.264.8450.0/10	1	register
19	0.264.8452.2	1	rod
20	0.190.8452.0	1	rotor blade
21	0.174.8440.0/10	1	pulley - X 100HP - X 130HP
21	0.273.8440.0/10	1	pulley - X 110HP
21	0.264.8440.0/10	1	pulley - X 150HP
22	2.0112.311.2	1	screw m 10 p.1.5 x 30
23	2.9439.550.0	1	alternator 55A MARELLI F 282 - FOR PREVIOUS VERSION-SEE REF.284 - 285 - 286 ☞ 2.9439.550.0 ☞ 08.00.23
23	2.9439.560.0	1	alternator 55A F 282/1 - FOR PREVIOUS VERSION-SEE REF.284 - 285 - 286 ☞ 2.9439.560.0 ☞ 08.00.24
23	2.9439.570.0	1	alternator 55A F 282/2 - FOR PREVIOUS VERSION-SEE REF.284 - 285 - 286 ☞ 2.9439.570.0 ☞ 08.00.25
24	2.1470.006.2	1	lock washer 10
25	2.1011.106.2	1	nut m 10 p.1.5
26	0.264.8451.0	1	bracket
27	2.1470.006.2	1	lock washer 10
28	2.0112.307.2	1	screw m 10 p.1.5 x 20
29	0.264.8463.0	1	crosspiece
30	0.243.8455.0	1	guard

258_273

STARTER PARTS

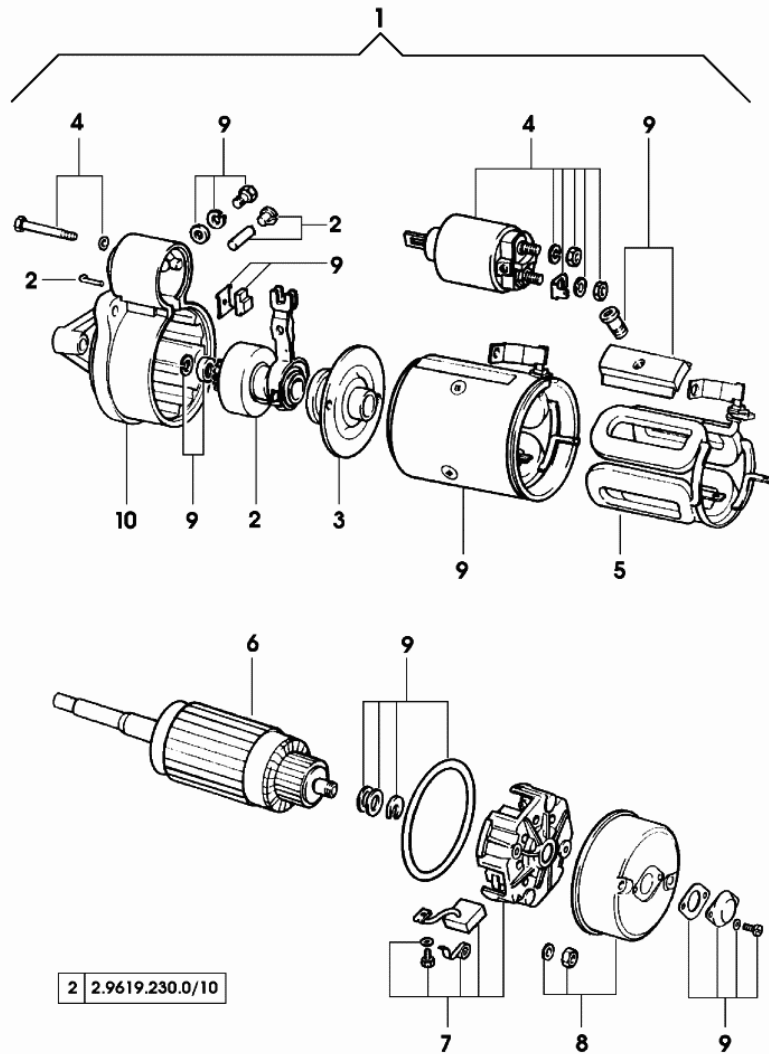

Fig.	Code	QTY	Name
1	0.000.0000.1	0	not serviceable - MARELLI - (2.9619.340.0)
2	0.009.4274.1	1	coupling
3	2.9619.160.2	1	support
4	2.9619.270.1	1	electromagnet
5	0.009.4274.0	1	field winding
6	0.009.4273.2	1	armature
7	0.009.4273.1	1	brush holder
8	0.009.4272.2	1	support
9	0.000.0000.1	0	not serviceable
10	0.009.4273.0	1	support

Section: ENGINE
CRANKCASE

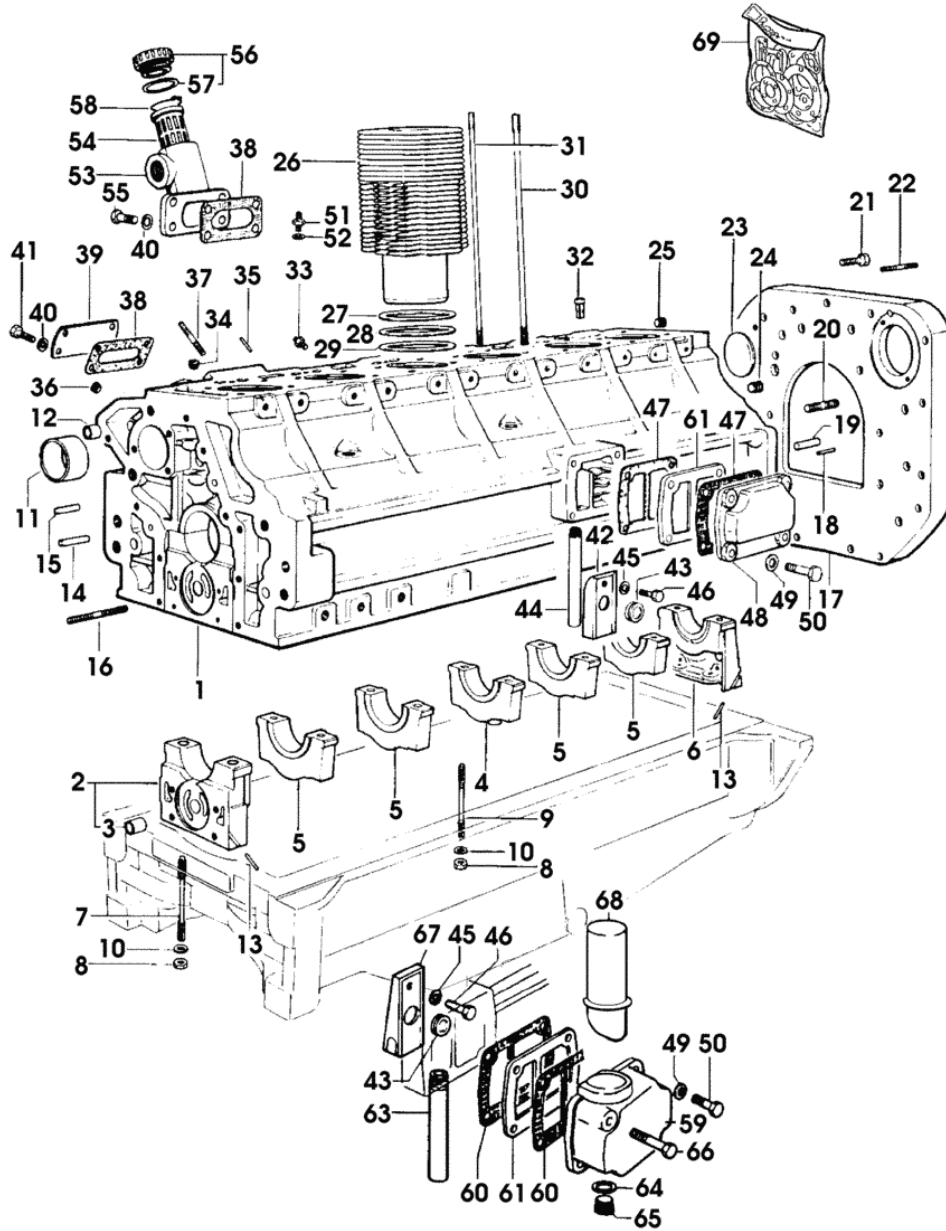
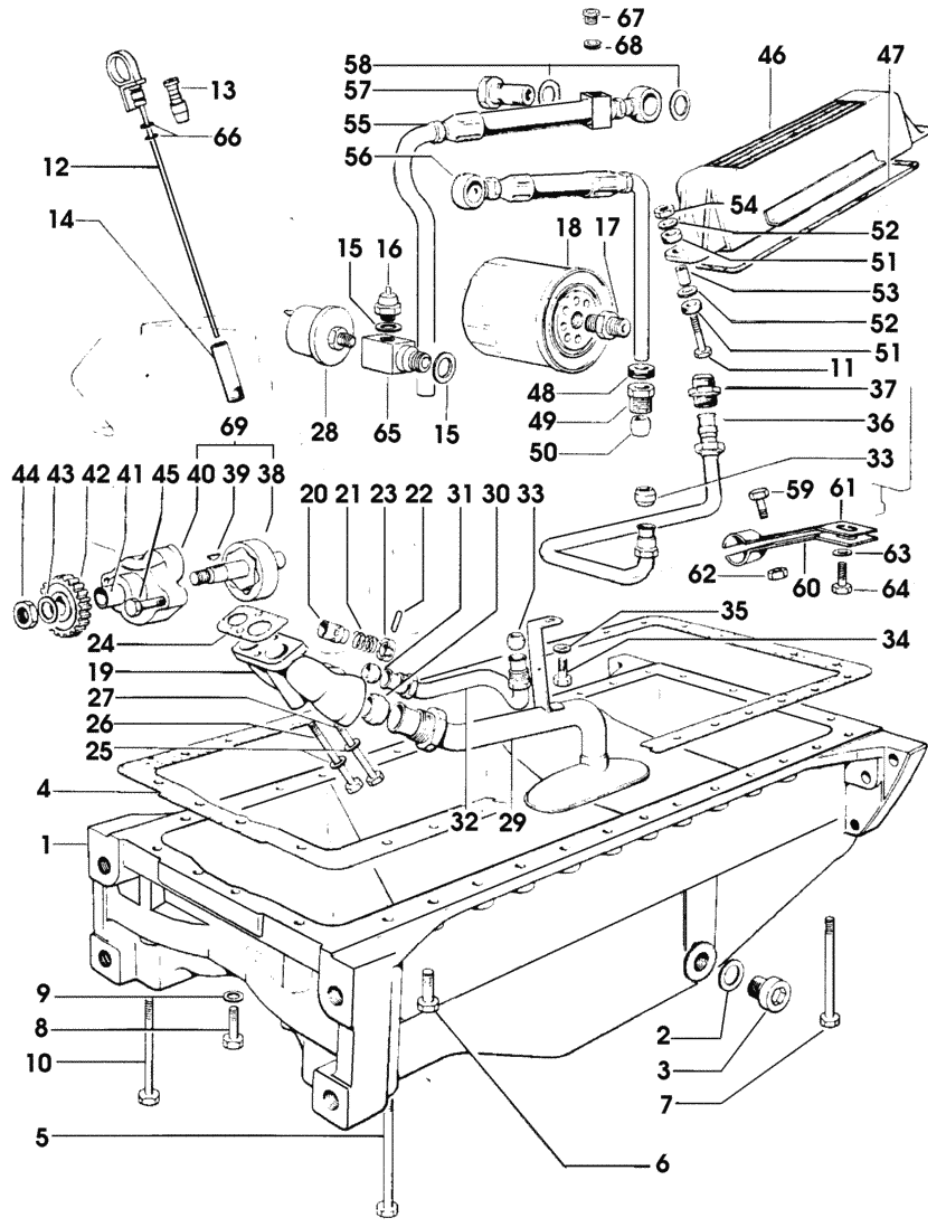

Fig.	Code	QTY	Name
1	0.047.1110.4/80	1	crankcase * 10564 <= X 110HP * 20306 <= X 130HP - N.1 045.1240.0 - N.2 2.0112.309.2 - N.2 2.1474.010.0
1	0.047.1150.4/20	1	crankcase - EXPORT U.S.A. * 10564 <= X 110HP - N.1 045.1240.0 - N.2 2.0112.309.2 - N.2 2.1474.010.0 * => 10565 - (...) <= X 110HP - N.1 071.1153.0 - N.1 071.1154.0 - N.1 044.1153.0/10 - N.1 071.1156.0 - N.1 071.1155.2 - N.4 2.0112.211.2 * (...) <= X 130
2	0.004.8774.3	1	support
3	2.1559.090.0/10	1	bushing 14.24x19.06x27
4	0.037.1114.0	2	support
5	0.029.1113.0	3	support
6	0.029.1116.0	1	support
7	0.021.1157.0	4	stud bolt
8	2.1019.026.7	14	special nut m 12 p.1.5
9	0.029.1117.0	10	stud bolt
10	2.1599.144.7	14	snoulder 12.5x23x4
11	0.037.1155.0	1	bushing
12	2.1559.111.0/10	2	bushing 11.5x14.1x10 - EXPORT U.S.A.
12	2.1559.149.0	1	bushing
13	0.029.1154.0/10	4	gasket
14	2.1699.114.0	1	pin 8x55
15	2.1651.711.0	1	pin 8 x 14
16	2.0432.025.7	2	stud bolt m 8 p.1.25 - 1.00 x 100
17	0.071.1150.0	1	flange
18	2.1653.708.0	2	pin 20306 <= X 130HP 10564 <= X 110HP
19	2.1651.911.0	2	cylindrical plug 12 x 24
20	2.0432.153.7	2	stud bolt m 10 p.1.5 / p.1.25 x 20
21	2.0112.513.2	11	screw m 14 p.2 x 35
22	2.0432.257.7	2	stud bolt m 12 p.1.75 - 1.25 x 30
23	2.3170.022.1	1	expansion plug 60
24	2.3130.003.1	2	plug 3/8" gas
25	2.3130.002.1	1	plug 1/4" gas

258_002

Section: ENGINE
LUBRICATION

Fig.	Code	QTY	Name
1	0.047.1510.0	1	oil pan
2	2.1560.054.0	1	gasket 21 x 26
3	2.3199.001.2	1	plug 1/2" gas
4	0.037.1512.0	1	gasket
5	2.0112.244.2	2	screw m 8 p.1.25 x 180
6	2.0112.215.2	30	screw m 8 p.1.25 x 40
7	2.0112.237.2	4	screw m 8 p.1.25x140
8	2.0112.219.2	2	screw m 8 p.1.25x50
9	2.1560.004.0	4	gasket 8.2 x 14
10	2.0112.231.2	2	screw m 8 p.1.25 x 110
11	2.0122.213.2	2	screw m 8 p.1x35
12	0.042.1513.2	1	dipstick
13	0.034.1551.0	1	gasket
14	0.044.1555.0	1	spacer
15	2.1560.008.0	2	gasket 12.2 x 18
16	2.7099.460.0	1	pressure switch
17	2.3339.094.1/10	1	pipe fitting m 20 p.1.5-3/4 gas
18	0.041.1556.0	1	oil filter element
19	0.052.1530.0	1	tip
20	0.052.1571.0	1	small piston
21	2.4019.270.1	1	spring 9.7x54x2
22	2.1630.213.0	1	roll pin 3x32
23	0.054.1558.0/10	1	stop
24	0.037.1557.0/20	1	gasket
25	2.1480.014.1	2	washer 8
26	2.0112.225.2	1	screw m 8 p.1.25 x 80
27	2.0112.231.2	1	screw m 8 p.1.25 x 110
28	2.7099.270.0	1	device
29	0.046.1531.3	1	tube
30	2.3359.017.1	1	nosepiece
31	2.3359.016.1	1	nosepiece
32	0.044.1560.2	1	tube
33	2.3359.015.1	2	nosepiece
34	2.0112.205.2	1	screw m 8 p.1.25 x 16
35	2.1310.004.2	1	flat washer 8.5
36	0.046.1543.2/10	1	tube
37	2.3339.159.1/10	1	pipe fitting
38	0.040.1524.3/50	1	oil pump => 14218 X 110HP => 25099 X 130HP
39	2.1720.005.0	1	key 4x5
40	0.047.1520.3/20	1	pump casing => 14218 X 110HP



258_012

Section: ENGINE
INJECTION PUMP PARTS

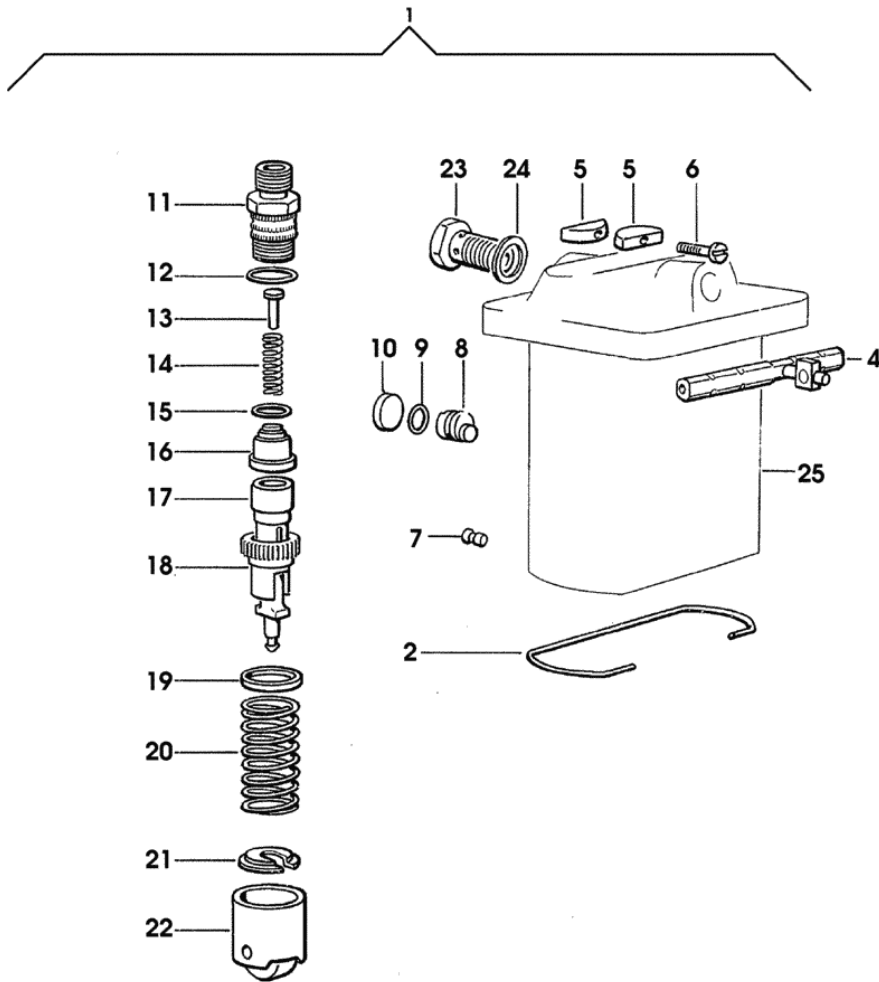
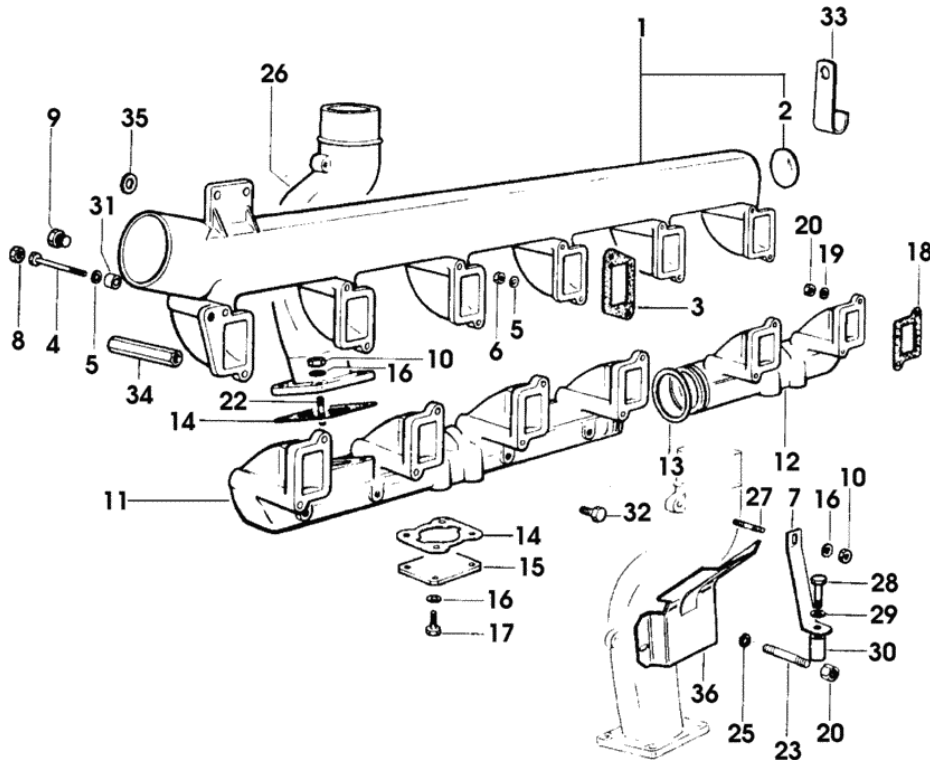

Fig.	Code	QTY	Name
1	2.4639.090.0/10	1	injector pump ☞ 2.4639.090.0/10
2	2.4639.060.2	1	spring
4	2.4639.060.1	1	rod
5	2.4629.010.2	4	terminal
6	2.0220.415.2	2	screw m 6 p.1x28
7	2.4649.281.0	3	pin
8	2.4649.280.7	3	pin
9	2.4649.280.8	3	'o' ring
10	2.4649.280.9	3	plug
11	2.4639.090.3	3	pipe fitting
12	2.4669.070.7	3	gasket
13	0.000.0000.1	0	not serviceable
14	0.002.1710.0	3	spring
15	2.4629.150.6	3	gasket
16	2.4639.090.2	3	valve
17	2.4639.090.1	3	pumping element
18	2.4639.090.4	3	sleeve
19	0.000.0000.1	0	not serviceable
20	2.4639.090.5	3	spring
21	2.4639.090.6	3	cap-washer
22	2.4639.090.7	3	tappets
23	2.3339.118.1	1	pipe union m 12 p.1.5
24	2.1560.008.0	2	gasket 12.2 x 18
25	0.000.0000.1	0	not serviceable

2.4639.090.0/10
 258_027

Section: ENGINE
INTAKE AND EXHAUST

Fig.	Code	QTY	Name
25	2.1310.004.2	4	flat washer 8.5 -> 2105 X 110HP -> 1651 X 130HP
26	0.072.1850.0/10	1	exhaust manifold
27	2.0432.153.7	1	stud bolt m 10 p.1.5 / p.1.25 x 20
28	2.0119.098.2	1	screw m 12 p.1.5x50
29	2.1310.007.2	1	flat washer 13.5
30	2.1579.140.2	1	spacer 13.3x20x29
31	2.1579.986.2	1	spacer 12x16x40
32	2.0122.211.2	2	screw m 8 p.1x30 2104 <- X 110HP 1650 <- X 130HP -> 2105 X 110HP -> 1651 X 130HP
33	2.6859.071.2	1	clamp
34	2.1099.103.2	5	special nut m 8 p.1x58,5 -> 2105 X 110HP -> 1651 X 130HP
34	2.1099.111.2	1	nut -> 2105 X 110HP -> 1651 X 130HP
35	2.1311.006.2	4	flat washer 8 -> 2105 X 110HP -> 1651 X 130HP
36	0.045.1850.0/20	1	shield -> 2105 X 110HP -> 1651 X 130HP



Section: FRONT AND REAR P.T.O.
P.T.O. - HYDRAULIC CONTROL

Fig.	Code	QTY	Name
36	2.1411.013.7	1	circlip Ø 32
37	0.264.8462.0	1	cap (...) <-
37	0.008.1331.0	1	guard -> (...) - (...) <-
43	0.9023.152.0	0	gasket
44	2.6519.029.0	1	cap -> (...)

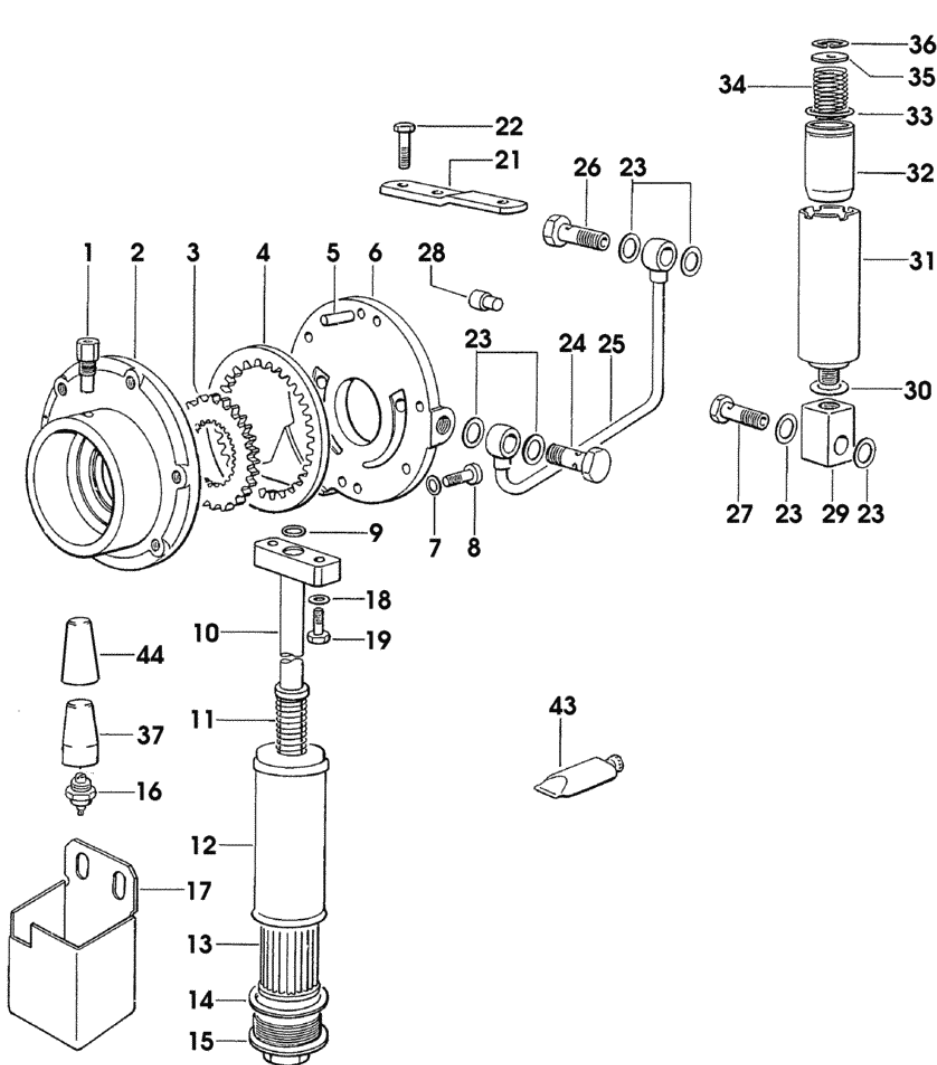

258_158

LASER 130

FRONT AXEL

GENERAL

4WD - FRONT SUPPORT.....	04.00.4
4WD - FRONT DRIVE AXLE.....	04.00.11
4WD - FRONT BRAKES.....	04.00.13
4WD - FRONT BRAKING SYSTEM.....	04.00.16
4WD - POWER STEERING CYLINDER.....	04.00.21
4WD - POWER STEERING CYLINDER.....	04.00.22
4WD - POWER STEERING CYLINDER.....	04.00.23
4WD - POWER STEERING CYLINDER - COMPONENTS.....	04.00.24
4WD - DIFFERENTIAL.....	04.00.30
DIFFERENTIAL LOCK CONTROL.....	04.00.32
4WD - AXLESHAFTS.....	04.00.35
4WD - DIFFERENTIAL LOCK CONTROL-FRONT.....	04.00.37
4WD - DIFFERENTIAL LOCK CONTROL-FRONT.....	04.00.38
4WD - DIFFERENTIAL LOCK CONTROL-FRONT.....	04.00.39
4WD - TRANSMISSION SHAFT.....	04.00.43
4WD - ENGAGEMENT CONTROL.....	04.00.45

Section: FRONT AXEL
4WD - POWER STEERING CYLINDER

Fig.	Code	QTY	Name
1	0.264.6342.4	1	jack
2	0.176.6371.0	2	ball joint
3	2.1423.026.7	4	circlip 35 x 1.5
4	0.009.4734.2	1	seal ring kit
5	0.176.6372.0	1	ring nut M 45X1.5 D.56/9
6	2.1421.019.1	1	circlip b 48
7	0.176.6377.1	1	piston mm 48
8	0.176.6376.1	1	bushing
9	2.1120.209.2	1	nut m 16 p.1.5
10	0.000.0000.1	0	not serviceable
11	0.275.6352.0	1	arm

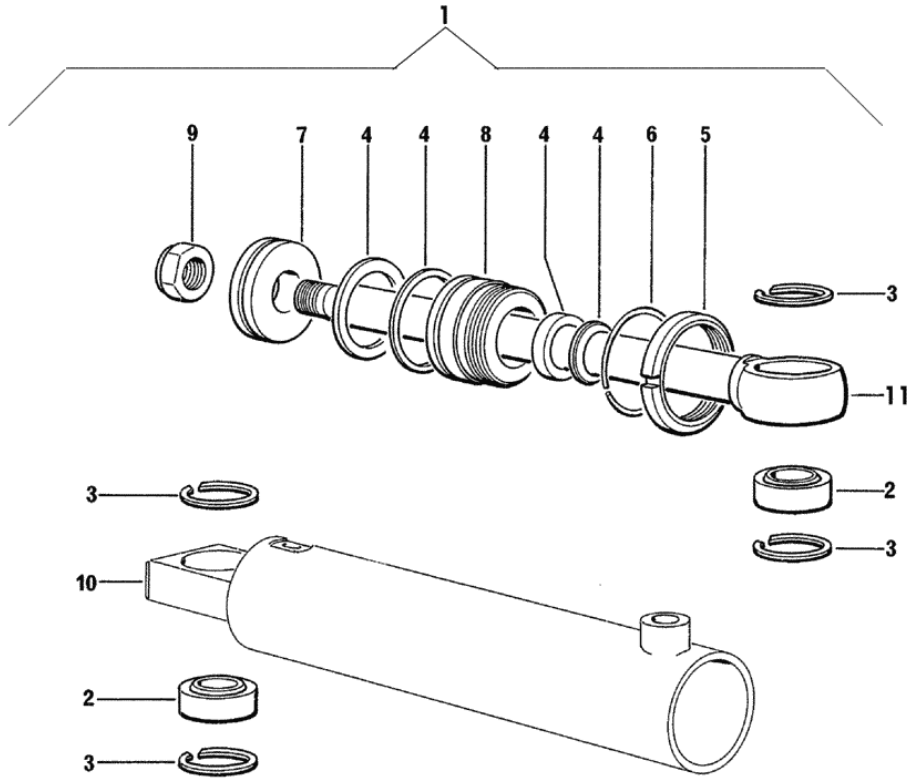

264.6342.4
264.6342.4/10
258_126

Section: FRONT AXEL
4WD - TRANSMISSION SHAFT

Fig.	Code	QTY	Name
1	0.269.2612.0	1	transmission shaft
2	0.163.2630.0	1	support
3	2.0112.315.2	2	screw m 10 p.1.5 x 40
4	2.1470.006.2	2	lock washer 10
5	2.1470.006.2	4	lock washer 10
6	2.2030.008.0	1	ball bearing 35x62x14
7	2.1420.022.0	2	circlip a 60
8	2.1520.217.0	2	oil seal 35x62x12
9	0.163.2614.0/10	1	tube
10	2.1631.819.0	1	roll pin 10x50
11	0.163.2620.0	1	flange
12	2.0129.038.1	4	screw m 10 p.1.25 x 25
13	2.1011.321.2	4	nut m 10 p.1.25
14	2.0112.307.2	4	screw m 10 p.1.5 x 20
15	2.3820.105.2	1	lubricator m 10 p.1 x 7
16	0.269.2632.2/10	1	guard
17	2.0112.205.2	9	screw m 8 p.1.25 x 16
18	2.1470.004.2	12	washer 8
19	0.236.2653.2	1	guard
20	0.236.2654.2	2	square
21	2.1579.901.2	2	spacer 12x20x5

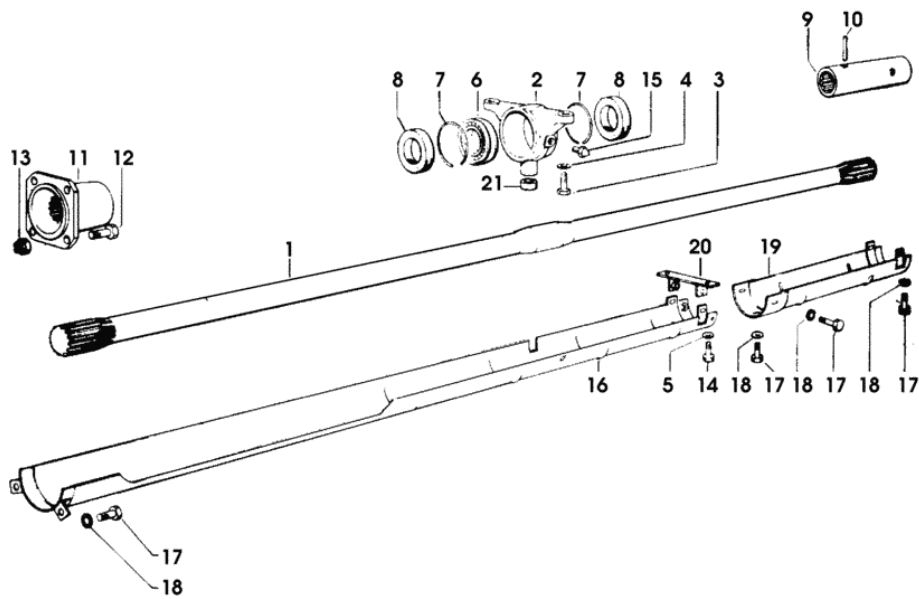

Section: GEAR
PUMP-COMPONENTS

Fig.	Code	QTY	Name
1	0.257.6538.4/10	1	pump
2	0.235.6557.6	1	seal ring kit
3	0.003.5099.0	1	rubber plug
4	0.257.6564.1	1	rod
5	0.000.0000.1	0	not serviceable
6	0.257.6691.1	1	coupling

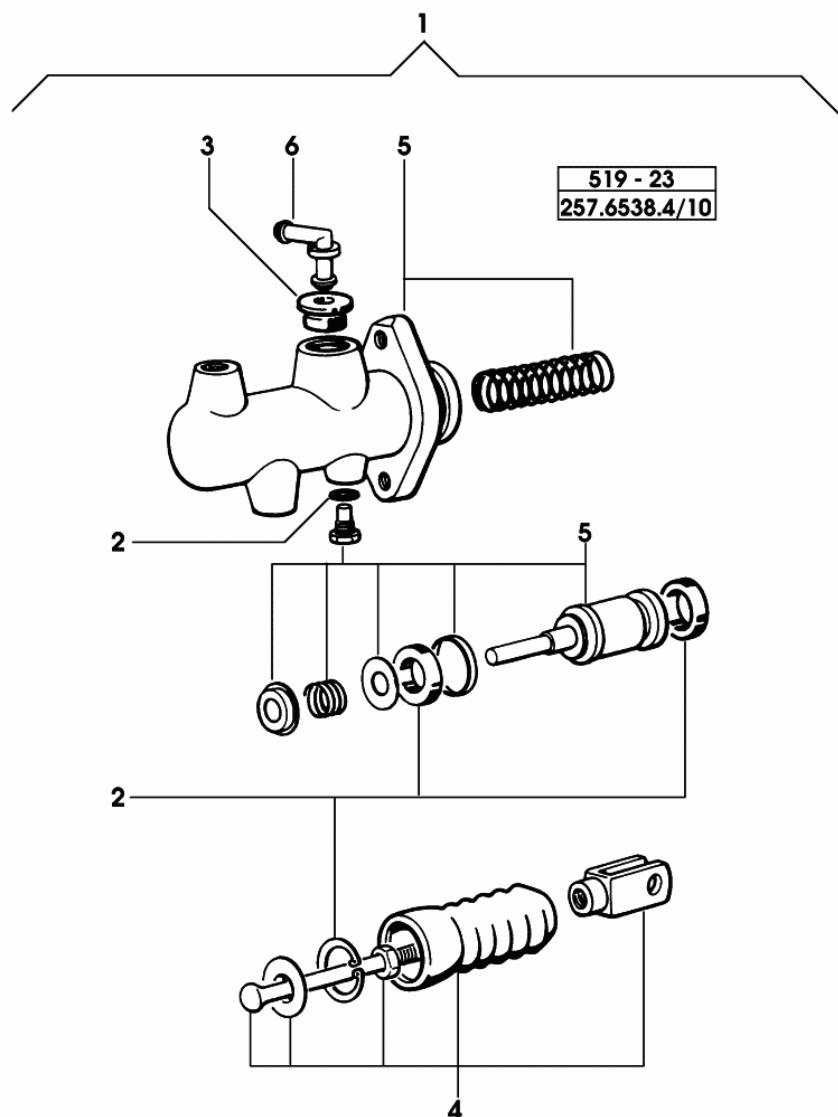

REVERSING GEAR AND SUPER REDUCTION GEAR UNITS

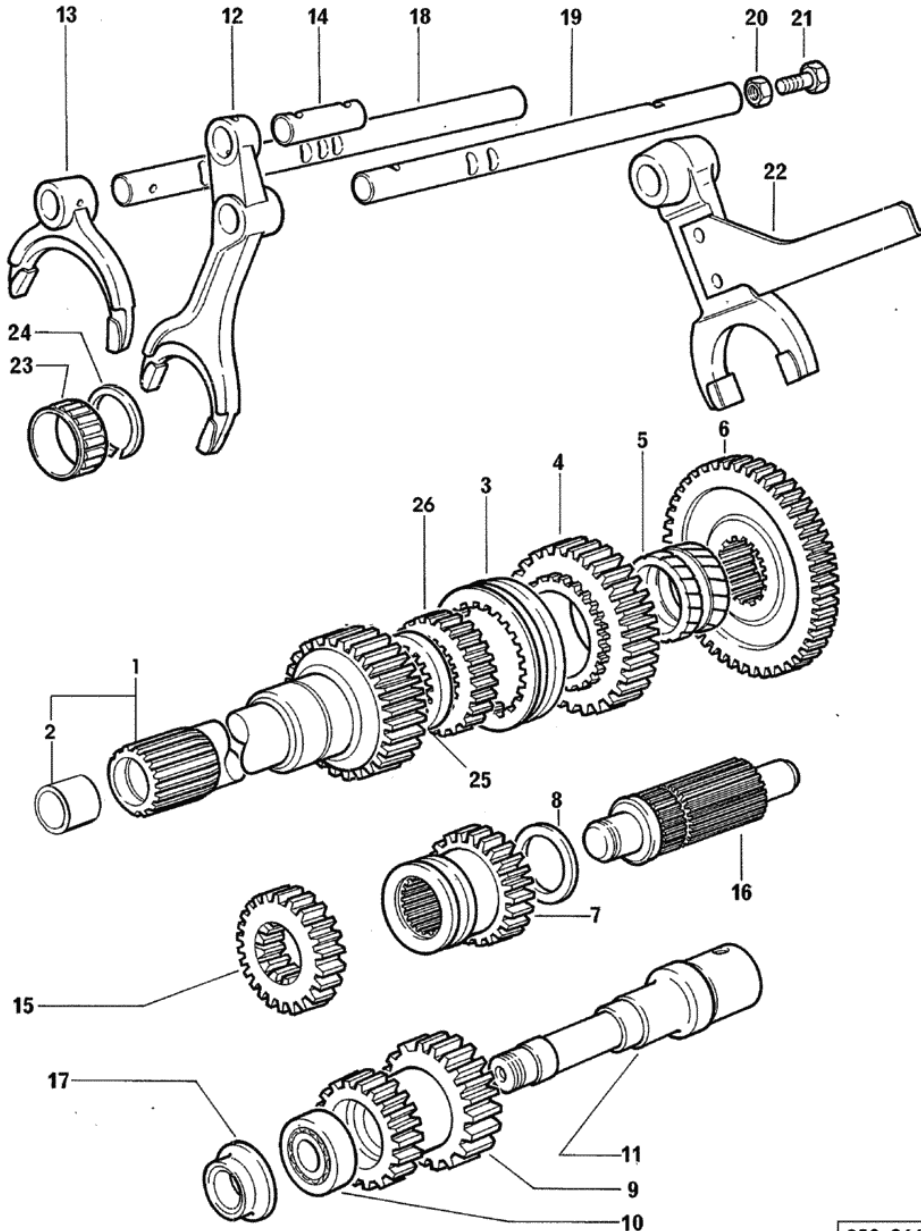

Fig.	Code	QTY	Name
1	0.258.3750.3	1	shaft
2	2.1555.515.0	1	bushing 30x34x30
3	0.264.3267.0	1	sleeve
4	0.264.3261.0	1	gear z = 27
5	0.264.3262.0	1	sleeve
6	0.264.3263.0	1	gear Z = 31
7	0.264.3264.0	1	gear z = 26
8	2.1599.250.0	1	snoulder 35x54x4
9	0.258.3751.0	1	gear
10	2.2999.177.0	1	bearing
11	0.258.3752.0	1	shaft
12	0.264.6485.0	1	fork
13	0.264.6486.0/10	1	fork
14	0.264.6487.0	1	rod
15	0.258.3753.0	1	gear
16	0.258.3755.0	1	shaft
17	0.258.3757.0	1	snoulder
18	0.264.6489.0	1	rod
19	0.258.3754.0	1	rod
20	2.1011.405.2	1	nut m 8 p.1
21	2.0122.211.2	1	screw m 8 p.1x30
22	0.188.6452.3/10	1	fork
23	2.2770.083.0	1	roller cage
24	2.1423.039.7	1	circlip
25	0.258.3756.0	1	spacer
26	0.264.3268.0	1	hub z = 27

258_066

Section: GEAR
DIFFERENTIAL

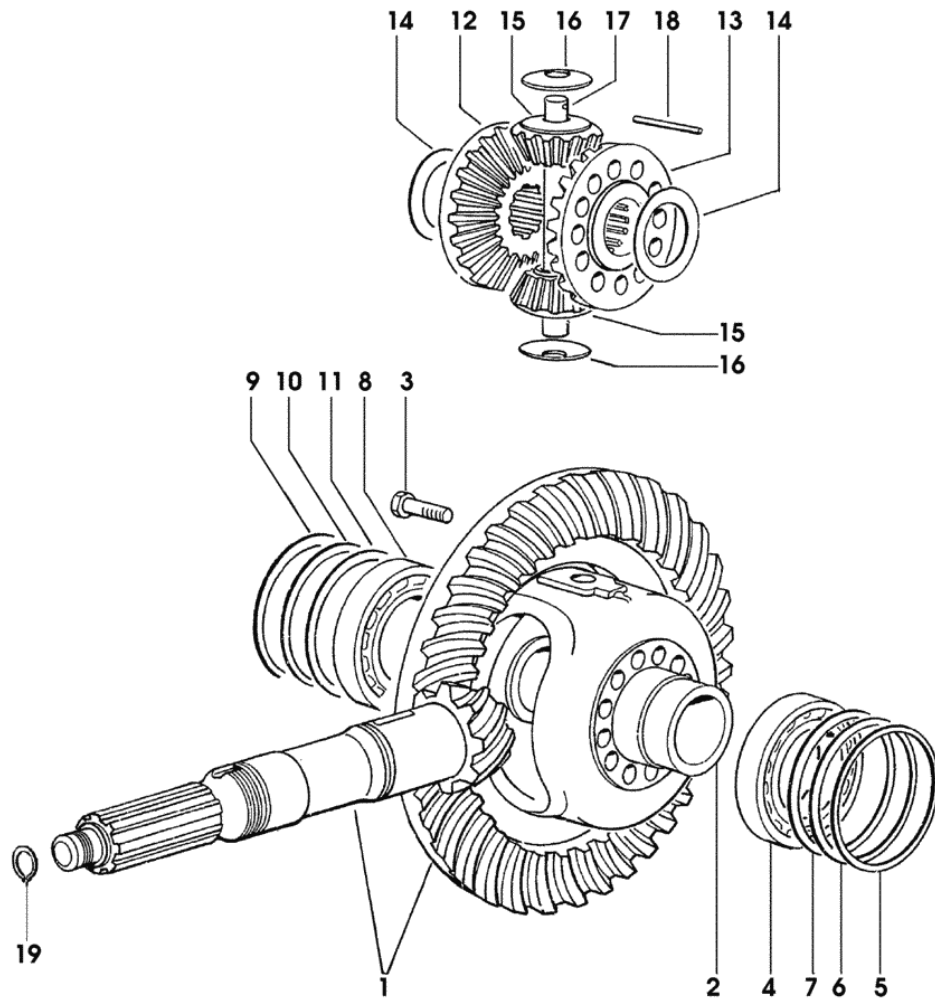

Fig.	Code	QTY	Name
1	0.232.3520.3/10	1	bevel gear Z = 10 / Z = 47
1	0.232.3551.3	1	bevel gear z=50 - z=9 25 Km/h
2	0.232.3510.0/10	1	differential carrier
3	2.0139.029.7	16	screw m 12 p.1.25x25
4	2.2521.015.0	1	roller bearing 70x125x26.25
5	2.1580.421.0	4	shim 108x124x0.15
6	2.1580.420.0	2	shim 108x124x0.50
7	2.1580.419.0	4	shim 108x124x0.20
8	2.2520.018.0	1	roller bearing 85x150x30.5
9	2.1589.089.0	4	snoulder 130x149x0.10
10	2.1589.090.0	2	snoulder 130x149x0.20
11	2.1589.091.0	4	snoulder 130x149x0.50
12	0.269.3522.0	1	crown wheel Z = 18
13	0.269.3523.0	1	crown wheel Z = 18
14	0.154.3551.0	2	snoulder
15	0.232.3524.0	2	planet gear Z = 10
16	0.232.3550.0	2	shim
17	0.258.3525.0/10	1	pin
18	2.1630.717.2	1	roll pin 8 x 50
19	2.1422.016.0	1	circlip 20

Section: S.A.C.

HYDRAULIC PUMP

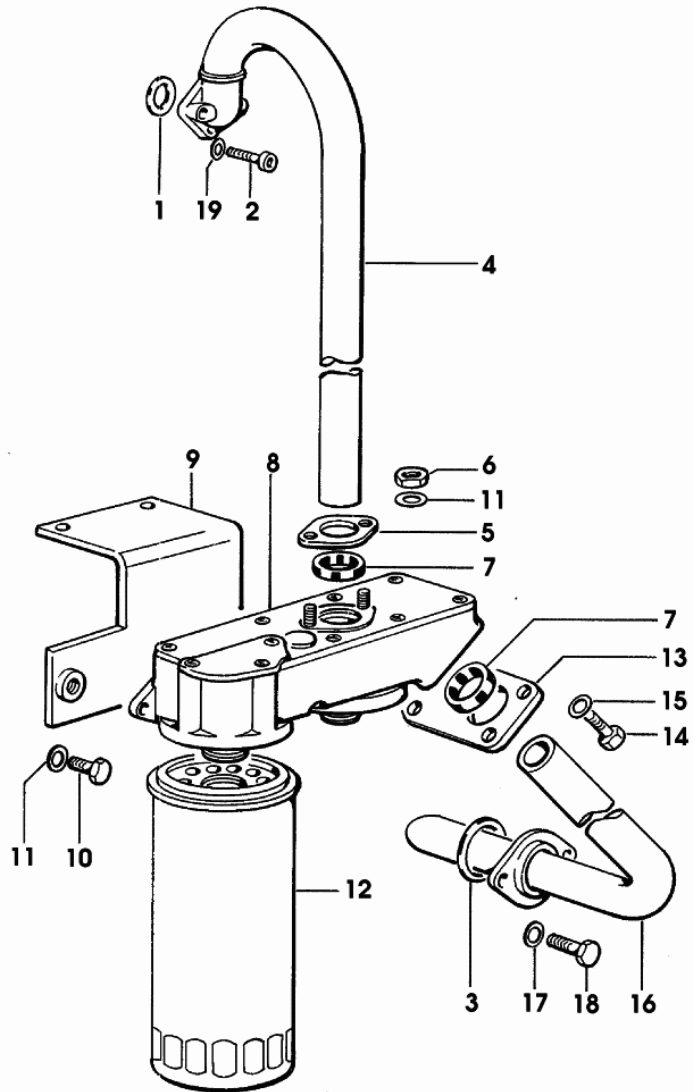

Fig.	Code	QTY	Name
1	2.1530.062.0	1	'o' ring 23.81 x 2.62
2	2.0312.206.2	3	screw m 8 p 1.25 x 20
3	2.1530.120.0	1	'o' ring 47.30x2.62
4	0.9107.252.3	1	tube
5	0.9107.253.0	1	flange
6	2.1011.105.2	2	nut m 8 p.1.25
7	0.255.8255.0/40	2	gasket
8	0.9107.259.3	1	head
9	0.9107.255.2/10	1	bracket
10	2.0112.209.2	2	screw m 8 p 1.25 x 25
11	2.1470.004.2	4	washer 8
12	2.4419.280.0	2	hydr.oil filter elem FT 4948
13	0.9107.254.0	1	flange
14	2.0112.207.2	4	screw m 8 p 1.25 x 20
15	2.1470.004.2	4	washer 8
16	0.9107.219.3	1	tube
17	2.1470.006.2	2	lock washer 10
18	2.0112.307.2	2	screw m 10 p.1.5 x 20
19	2.1480.014.1	4	washer 8

258_350

CONTROL TIE RODS AND LEVERS

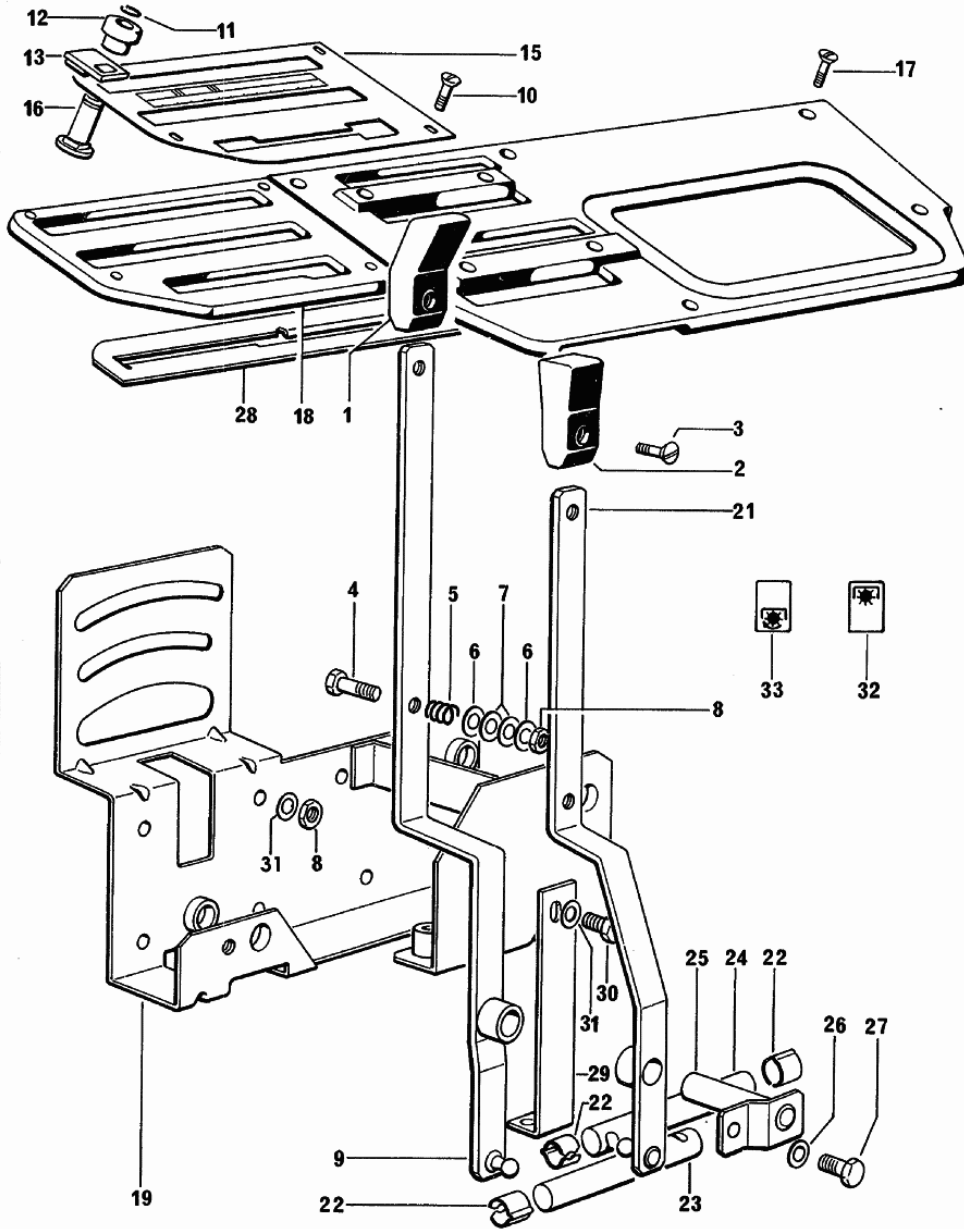
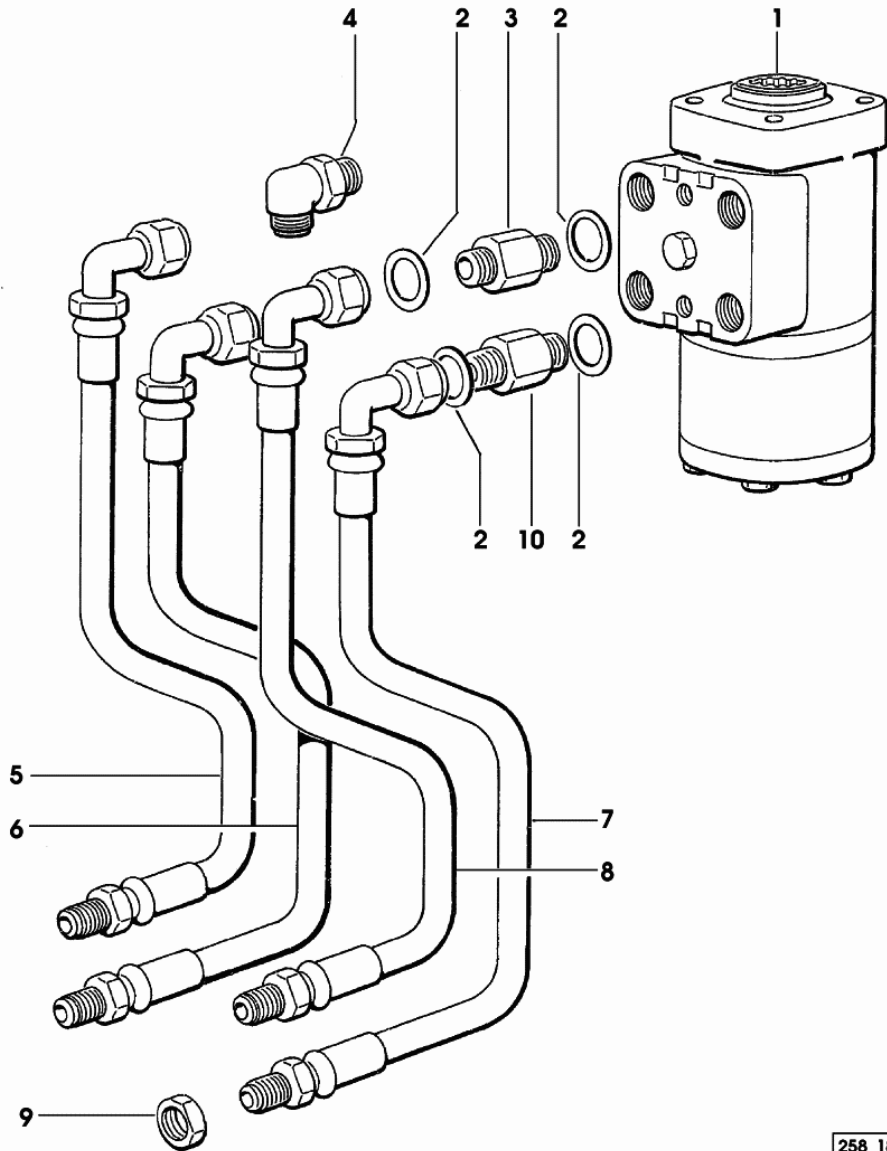

Fig.	Code	QTY	Name
1	0.9030.669.0	1	knob
2	0.9050.652.0	1	knob
3	2.0322.405.2	2	screw m 6 x 15
4	2.0112.215.2	2	screw m 8 p.1.25 x 40
5	2.4019.219.0	2	spring
6	2.1599.245.0	4	snoulder 8.5 x 32 x 2.0
7	0.9030.672.0	4	ring 8.5 x 32 x 3.0
8	2.1011.105.2	5	nut m 8 p.1.25
9	0.9107.652.3	1	lever
10	2.0322.409.6	2	screw m 6 p.1x30
10	2.0322.403.2	2	screw m 6 p.1 x 10
11	2.1430.007.7	2	circlip 6, d128
12	0.9107.669.2	2	knob
13	0.9107.668.0	2	stop
15	0.000.0000.1	0	not serviceable
			1871 <- X 100HP
			2434 <- X 110HP
			1750 <- X 130HP
			1434 <- X 150HP
15	0.9107.666.0/30	1	small plate
			-> 1872 X 100HP
			-> 2435 X 110HP
			-> 1751 X 130HP
			-> 1435 X 150HP
16	0.9107.667.0/10	2	screw
17	2.0332.409.2	6	screw m 6 x 30
18	0.9107.665.2/10	1	front grille
19	0.9107.654.2/50	1	support
21	0.9107.653.3	1	lever
22	0.257.6757.0	4	spring
23	0.9107.636.0	1	rod
24	0.9107.626.0	1	rod
25	0.9107.660.2	1	pin
26	2.1470.002.2	1	washer 6, d128
27	2.0112.007.2	1	screw m 6 p.1 x 20
28	0.9107.680.0/10	1	small plate
29	0.9107.672.0/20	1	brace
30	2.0112.207.2	2	screw m 8 p 1.25 x 20
31	2.1470.004.2	10	washer 8
32	2.9919.887.0	1	plate
			- EXPORT SF
33	2.9919.888.0	1	plate
			- EXPORT SF

258_358

POWER STEERING

Fig.	Code	QTY	Name
7	0.257.6352.3/10	1	2304 <- X 110HP 1750 <- X 130HP 1324 <- X 150HP tube dx/rh/re -> 1872 X 100HP -> 2305 X 110HP -> 1751 X 130HP -> 1325 X 150HP
8	0.257.6351.3	1	tube sx/lh/li
9	2.1099.077.2	4	special nut 3/4" - 16
10	2.3339.341.2	2	pipe fitting m 18 p.1.5 1871 <- X 100HP 2304 <- X 110HP 1750 <- X 130HP 1324 <- X 150HP
10	2.3339.400.2	2	pipe fitting 3/4"-16 - m 18p.1.5 -> 1872 X 100HP -> 2305 X 110HP -> 1751 X 130HP -> 1325 X 150HP



258_182

CLICK HERE TO **DOWNLOAD** THE COMPLETE MANUAL

- Thank you very much for reading the preview of the manual.
- You can download the complete manual from: www.heydownloads.com by clicking the link below



- Please note: If there is no response to CLICKING the link, please download this PDF first and then click on it.

CLICK HERE TO **DOWNLOAD** THE COMPLETE MANUAL