

1A2

9501 PULL-TYPE COMBINE

H41820 -UN-01JAN94



JOHN DEERE 9501 PULL-TYPE COMBINE WITH BELT PICKUP AND PICKUP PLATFORM

(635401-645700)

(SPECIFICATIONS AND DESIGN SUBJECT TO CHANGE WITHOUT NOTICE)

CLICK HERE TO **DOWNLOAD** THE COMPLETE MANUAL

- Thank you very much for reading the preview of the manual.
- You can download the complete manual from: www.heydownloads.com by clicking the link below



- Please note: If there is no response to CLICKING the link, please download this PDF first and then click on it.

CLICK HERE TO **DOWNLOAD** THE COMPLETE MANUAL

1A12

9501 PULL-TYPE COMBINE

ALPHABETICAL INDEX - CONTINUED

GRID	PAGE	GRID	PAGE
2C9	SIEVE ELEMENT	120-42	
2C11	SIEVE FRAME	120-44	
1E6	SINGLE ACCUMULATOR	70-20	
1I7	SLIP CLUTCH, FEEDER HOUSE	110-26	
1E21	SOLENOID CONTROL VALVE BI-DIRECTIONAL MODULE POPPET KIT	70-37	
1E22	SOLENOID CONTROL VALVE BI-DIRECTIONAL MODULE RELIEF KIT	70-38	
1E19	SOLENOID CONTROL VALVE BI-DIRECTIONAL MODULE, CYLINDER SPEED	70-35	
1F6	SOLENOID CONTROL VALVE BRACKETS	70-48	
1E23	SOLENOID CONTROL VALVE DOUBLE PILOTED MODULE, AUGER SWING	70-39	
1F1	SOLENOID CONTROL VALVE DOUBLE PILOTED MODULE, GRAIN TANK UNLOADING	70-42	
1F4	SOLENOID CONTROL VALVE MODULE ASSEMBLY AND MOUNTINGS	70-46	
1F5	SOLENOID CONTROL VALVE MODULE ASSEMBLY AND MOUNTINGS	70-47	
1E14	SOLENOID CONTROL VALVE UNBALANCED LOAD MODULE (HEADER LIFT MODULE)	70-30	
1E13	SOLENOID CONTROL VALVE UNLOAD MODULE	70-28	
1E16	SOLENOID CONTROL VALVES, ADJUSTABLE STOP KIT	70-32	
1E17	SOLENOID CONTROL VALVES, ARMATURE KIT, HEADER LIFT MODULE	70-33	
2E9	SPEED CONTROL LINKAGE, FAN DRIVE (-640400)	120-90	
2E11	SPEED CONTROL LINKAGE, FAN DRIVE (640401-)	120-92	
2E13	SPEED CONTROL, FAN DRIVE SHEAVE LINKAGE	120-94	
1D10	SPINDLE, HOUSING, AND WHEEL	50-19	
2D1	SPREADER CURTAIN	120-58	
2G15	SPREADER, CHAFF, MOTOR, LINES AND HOSES	120-144	
2F23	SPREADER, STRAW	120-128	
2K9	SPREADER, STRAW, BELTS	170-3	
2I5	SPROCKET, UPPER CLEAN GRAIN ELEVATOR	130-10	
2H5	SPROCKETS, TAILINGS ELEVATOR CONVEYOR	120-158	
1C20	STAND, JACK, HITCH BEAM	50-4	
2A22	STONE TRAP, DOOR AND FEEDER HOUSE/ SEPARATOR SEAL	120-6	
2K9	STRAW CHOPPER BELTS	170-3	
2F3	STRAW CHOPPER DECK, SUPPORTS AND FINS	120-108	
2F19	STRAW CHOPPER DOOR	120-124	
2E23	STRAW CHOPPER DRIVE SHIELDS (-640400)	120-104	
2F1	STRAW CHOPPER DRIVE SHIELDS (640401-)	120-106	
2E19	STRAW CHOPPER DRIVES (FRONT)	120-100	
2E21	STRAW CHOPPER DRIVES (REAR)	120-102	
2F11	STRAW CHOPPER HOUSING AND KNIFEBACK (-640400)	120-116	
2F9	STRAW CHOPPER HOUSING AND KNIFEBANK (-640400)	120-114	
2F13	STRAW CHOPPER HOUSING AND KNIFEBANK (640401-)	120-118	
2F15	STRAW CHOPPER HOUSING AND KNIFEBANK (640401-)	120-120	
2F5	STRAW CHOPPER ROTOR AND SHEAVE	120-110	
1B8	STRAW CHOPPER SENSOR BRACKET	40-20	
2F23	STRAW SPREADER	120-128	
2C21	STRAW SPREADER DRIVE, SHIELD AND STRAW WALKER CRANKS	120-54	
2F21	STRAW SPREADER MOUNTING AND GUARD	120-126	
1B12	STRAW WALKER (PLUGGING) SENSING SWITCH	40-24	
2C17	STRAW WALKER BEARING CONVERSION (-1990)	120-50	
2C21	STRAW WALKER CRANKS, STRAW SPREADER DRIVE AND SHIELD	120-54	
2D23	STRAW WALKER DRIVE GEARCASE	120-80	
2E1	STRAW WALKER DRIVE GEARCASE	120-82	
2E3	STRAW WALKER, CONVEYOR AUGERS, SIEVE AND CHAFFER DRIVE	120-84	
2C19	STRAW WALKERS	120-52	
2C15	STRAW WALKERS (-1990)	120-48	
2J23	STRAWCHOPPER TOP BELT GUIDE (TRAP)	130-54	
1C15	SUPPLEMENTARY TERMINALS AND CONNECTORS	40-52	
2J7	SUPPORT AND BRACES, AUGER	130-36	
1I5	SUPPORT, FEED PLATE	110-24	
1G5	SUPPORT, LANDING	80-10	
2H6	SUPPORT, LOWER TROUGH	120-159	
2D5	SUPPORTS AND VARIABLE SHEAVE, PRIMARY COUNTERSHAFT	120-62	
1F15	SWING, UNLOADING AUGER, HYDRAULIC CYLINDER KIT	70-58	
1B12	SWITCH, SENSING, STRAW WALKER PLUGGING	40-24	
2J7	SWIVEL SUPPORT AND BRACES, AUGER	130-36	
2J7	SWIVEL, AUGER SUPPORT	130-36	
2J5	SWIVEL, HORIZONTAL UNLOADING AUGER	130-34	
1D18	SYSTEM, HYDRAULIC, REEL DRIVE FRONT AND L.H. SIDE	70-6	
1D16	SYSTEM, TRACTOR RETURN	70-4	
1D16	SYSTEM, TRACTOR SUPPLY	70-4	
1F11	SYSTEM, UNLOADING AUGER ENGAGE	70-54	
T			
1B22	TAIL LIGHTS	40-34	
2H6	TAILINGS DRIVE BRACKET	120-159	
2H5	TAILINGS ELEVATOR CONVEYOR BEARINGS	120-158	
2H5	TAILINGS ELEVATOR CONVEYOR CHAIN	120-158	
2H5	TAILINGS ELEVATOR CONVEYOR SPROCKETS	120-158	
2H3	TAILINGS ELEVATOR HOUSING	120-156	
2J24	TANK, GRAIN, SAMPLING TROUGH	130-56	
1C21	TELESCOPING POWERSHAFT AND SHIELD	50-5	
1C13	TERMINAL AND WIRING KIT	40-50	
1C7	TERMINALS, ELECTRICAL, WEATHERPACK	40-44	
1C15	TERMINALS, SUPPLEMENTARY, AND CONNECTORS	40-52	
2A20	THRESHING CYLINDER COVER	120-4	
2B3	THRESHING CYLINDER, RASP BAR	120-12	
2E5	TIGHTENER AND BEATER DRIVE SHEAVES	120-86	
2D13	TIGHTENER, CYLINDER DRIVE, DUAL-RANGE	120-70	
2E15	TIGHTENER, FEEDER HOUSE DRIVE	120-96	
1I3	TIGHTENER, GUIDES AND FEEDER CONVEYOR DRIVE CHAIN	110-22	
2G23	TIGHTENER, LOWER TAILINGS AUGER	120-152	
2H7	TIGHTENER, LOWER TAILINGS AUGER CHAIN	120-160	
2H8	TIGHTENER, LOWER TAILINGS AUGER DRIVE	120-162	
1H5	TOOL BOX	80-36	
2I19	TOP, TANK, GRAIN	130-24	
1D16	TRACTOR RETURN SYSTEM	70-4	
1D16	TRACTOR SUPPLY SYSTEM	70-4	
2A22	TRAP, STONE	120-6	
1B22	TURN LIGHTS	40-34	
U			
1D9	UNIVERSAL JOINT SHIELD (REAR)	50-18	
1C22	UNIVERSAL JOINT, REAR	50-6	
1D9	UNIVERSAL SHIELD, GEAR CASE	50-18	
2K9	UNLOADING AUGER BELTS	170-3	

1A23

FC: 5285

ELECTRICAL

CONTROL BOX HARDWARE KIT - CONTINUED

KEY	PART NO.	PART NAME	QTY	SERIAL NO.	REMARKS
1	SCREW	2		4-48NF X 3/8 PAN HEAD
2	SCREW	4		4-40NC X 3/8 PAN HEAD
3	SCREW	2		SPECIAL TAPPING
4	SCREW	4		8-32 X 3/8 SELF TAPPING FL HD
5	SPACER	2		8-32NC X 7/8
6	SPACER	2		4-40NC X 3/4
7	SCREW	2		10-24NC X 3/8 SELF TAPPING PN HD
8	SCREW	2		8-32NC X 3/8 PN HD
9	SPACER	2		4-40NC X 7/8
10	SPACER	2		4-40NC X 1-1/2
11	SPACER	2		4-40NC X 1-3/4
12	CLIP	1		RELAY
13	AH200816	PACKAGE OF PARTS	1		

1B7

FC: 5281

ELECTRICAL

L.H. MAIN WIRING HARNESS, L.H. CENTER - CONTINUED

KEY	PART NO.	PART NAME	QTY	SERIAL NO.	REMARKS
1	AH200280	WIRING HARNESS	1		
2	AH130222	CLAMP	3		
3	14M7299	FLANGE NUT	3	M12	
4	37M7083	SCREW	3	M8 X 12	
5	AH90990	CLIP	4		
6	AH89557	CLIP	8		
7	19M7865	SCREW	4	M8 X 16	
	14M7298	FLANGE NUT	5	M8	
8	AH200648	MODULE	1		
9	AH89486	CLIP	1		
10	37M7083	SCREW	1	M8 X 12	
	24M7055	WASHER	1	8.400 X 16 X 1.600 MM	
11	12M7032	LOCK WASHER	2	8.400 MM	
12	24M7055	WASHER	1	8.400 X 16 X 1.600 MM	
13	RE12363	CONNECTOR	1	(PKG OF 3) - TO FAN SPEED CONTROL MOTOR	
	R78048	TERMINAL NIPPLE	1	(PKG OF 5)	
14	AE44392	CONNECTOR	1	4 HOLES, FEMALE - TO REEL SPEED CONTROL MOTOR	
	R77465	SOCKET CONTACT	1		
15	AH135787	ELECTRICAL PLUG	1		
	H141325	CONNECTOR	1		

1B17

FC: 5234

ELECTRICAL

HARVESTRAK MONITOR SYSTEM AND WIRING HARNESS - CONTINUED

KEY	PART NO.	PART NAME	QTY	SERIAL NO.	REMARKS
1	03M7183	BOLT	10		M8 X 16
	14M7298	FLANGE NUT	10		M8
2	AH135047	BRACKET	2		(SUB AH141038)
	AH141038	SUPPORT	2		
3	AH126272	SENSOR	4		
4	12H295	LOCK WASHER	16		0.190", (INTERNAL TOOTH)
5	21H1427	SCREW	16		0.190" X 1/2"
6	H132812	RETAINER	1		RIGHT-HAND
	H132813	RETAINER	1		LEFT-HAND
7	37M7083	SCREW	2		M8 X 12, (SELF-TAPPING)
8	H114411	FINGER	2		
9	19M7863	SCREW	2		M6 X 25
	14M7303	FLANGE NUT	2		M6
10	AH125672	DEFLECTOR	2		
11	19M7162	CAP SCREW	4		M8 X 16
	14M7298	FLANGE NUT	4		M8
12	T74410	CLAMP	2		
13	19M7784	SCREW	4		M10 X 20
	14M7298	FLANGE NUT	8		M8
14	AH89557	CLIP	7		
15	AH128422	WIRING HARNESS	1		
16	AH77724	CLIP	6		
17	37M7089	SCREW	2		M6 X 12, (SELF-TAPPING)
18	H140074	PLATE	2		(SUB H87268)
19	H118422	ELECTRICAL PLUG	1		9 HOLES, FEMALE (TO PRE-AMP)
	R77465	SOCKET CONTACT	AR		
20	H140414	DEFLECTOR	2		
21	03M7184	BOLT	8		M8 X 20
22	14M7396	LOCK NUT	8		M8
23	AH77279	CLIP	2		
24	AH200061	SUPPORT	1		

1C2

FC: 5245

ELECTRICAL

SEPARATOR FAN DRIVE ADJUSTING MOTOR - CONTINUED

KEY	PART NO.	PART NAME	QTY	SERIAL NO.	REMARKS
1A	AH124567	MOTOR	1		ADAPTER HARNESS AH143997 PLUS TWO ADAPTER AH106612 RELAYS MUST BE ORDERED WITH MOTOR AH143903 WHEN INSTALLED IN COMBINATION WITH EXISTING POWER DISTRIBUTION BOARD AND L.H. WIRING HARNESS.
1B	AH143903	MOTOR	1		(USE WITH AH143904, 19M8321 AND 14M7165)

1C12

FC: 5281

ELECTRICAL

ELECTRICAL CONNECTOR SERVICE KIT - CONTINUED

KEY	PART NO.	PART NAME	QTY	SERIAL NO. OR YEAR	REMARKS
35	R77469	TERMINAL	1		(PKG. OF 5) 18 GA.
36	RE11156	TERMINAL	1		(B) MALE
37	RE11157	TERMINAL	1		(B) FEMALE
38	R70222	PIN CONTACT	1		(D) (H)
39	R70221	ELECTRICAL PLUG	1		(E)
40	R70219	PLUG	1		(PKG. OF (2) R70218 AND (2) R70219) 10 WAY
	R70217	PLUG	1		(PKG. OF (2) R70216 AND (2) R70217) 7 WAY
	R70215	PLUG	1		(PKG. OF (2) R70214 AND (2) R70215) 4 WAY
	R70213	PLUG	1		(PKG. OF (2) R70212 AND (2) R70213) 3 WAY
41	R70211	CONNECTOR	1		(PKG. OF (2) R70210 AND (2) R70211) 2 WAY
	R70218	RECEPTACLE	1		ORDER R70219 WHICH CONTAINS (2) R70218 AND (2) R70219
	R70216	RECEPTACLE	1		ORDER R70217 WHICH CONTAINS (2) R70216 AND (2) R70217
	R70214	RECEPTACLE	1		ORDER R70215 WHICH CONTAINS (2) R70214 AND (2) R70215
	R70212	RECEPTACLE	1		ORDER R70213 WHICH CONTAINS (2) R70212 AND (2) R70213
	R70210	RECEPTACLE	1		(ORDER R70211) ORDER R70211 WHICH CONTAINS (2) R70210 AND (2) R70211
42	AR91793	SOCKET CONTACT	1		(D)
43	R30378	SPRING	1		(C)
44	R77474	CONNECTOR	1		(A) 6 WAY
45	R77470	TERMINAL	1		SPLICE (PKG. OF 15) 16-18-20 OR 22 GA. WIRE
	R77471	TERMINAL	1		(C) (G) SPLICE
	R77472	TERMINAL	1		(A) SPLICE (8 GA. WIRE)
	R77473	TERMINAL	1		(A) SPLICE (6 GA. WIRE)
46	R65607	TERMINAL	1		(C) (18 OR 20 GA. WIRE)
47	U46664	TERMINAL	1		(C) (F)
48	R32026	TERMINAL	1		(D) (F)
49	R65602	SOCKET CONTACT	1		(C) 16 OR 18 GA. WIRE
50	R70220	TERMINAL	1		(C) 18 OR 20 GA. WIRE
51	R77489	TERMINAL	1		(D) 14-16-18 OR 20 GA. WIRE; NO. 10 EYELET
	R77493	TERMINAL	1		(D) (G) NO. 10 EYELET
	R77488	TERMINAL	1		(D) 14-16-18 OR 20 GA. WIRE; 3/8" EYELET
	R77490	TERMINAL	1		(D) (G) (1/2" EYELET)
52	R77496	TERMINAL	1		(D) (F) NO. 8 SPADE
	R77495	TERMINAL	1		(D) 18 GA. WIRE; NO. 10 SPADE
53	R77497	TERMINAL	1		(D) (F) NO. 6 SPADE
54	R77491	TERMINAL	1		(D) (G) 3/8" EYELET
	R77492	TERMINAL	1		(D) (G) 1/4" EYELET
55	R77494	TERMINAL	1		(D) 6 OR 8 GA. WIRE; 1/4" EYELET
56	R77502	TUBE	1		(PKG. OF 8) 3/8", HEAT SHRINK
	R77503	TUBE	1		(PKG. OF 8) 3/16", HEAT SHRINK
57	RE11154	KIT	1		(SUB PM797NA)
	PM797NA	KIT	1		

- (A) PKG. OF 2
- (B) PKG. OF 3
- (C) PKG. OF 10
- (D) PKG. OF 20
- (E) PKG. OF 25
- (F) 14 OR 16 GA. WIRE
- (G) 10 OR 12 GA. WIRE
- (H) 14-16 OR 18 GA. WIRE

1C23

FC: 5314

POWER TRAIN

MAIN POWERSHAFT - CONTINUED

KEY	PART NO.	PART NAME	QTY	SERIAL NO.	REMARKS
1	N166516	PRESSED FLANGED HOUSING	2		
2	JD9305	BALL BEARING	4		
3	AH200111	BRACKET	1		
4	22H979	SET SCREW	4	3/8" X 3/8"	
5	JD8579	ECCENTRIC LOCKING COLLAR	4		
6	19H1974	CAP SCREW	2	1/2" X 2-3/4"	
	12H301	LOCK WASHER	2	1/2"	
	14H809	NUT	2	1/2", (SUB 14H1040)	
	14H1040	NUT	2	1/2"	
7	H94998	CLAMP	2		
8	19H1815	CAP SCREW	4	1/2" X 1-1/4"	
	12H301	LOCK WASHER	4	1/2"	
	14H809	NUT	4	1/2", (SUB 14H1040)	
	14H1040	NUT	4	1/2"	
9	19H1732	CAP SCREW	12	3/8" X 1-1/4"	
	12H304	LOCK WASHER	12	3/8"	
	14H812	NUT	12	3/8"	
10	19H1731	CAP SCREW	2	3/8" X 1"	
	12H304	LOCK WASHER	2	3/8"	
11	AH93304	BRACKET	2	(SUB AH139138)	
12	AH200122	SHAFT	1		
13	19H1731	CAP SCREW	9	3/8" X 1"	
	12H304	LOCK WASHER	9	3/8"	
	14H812	NUT	9	3/8"	
14	AH200144	BRACKET	3		
15	24H1305	WASHER	6	13/32" X 13/16" X 0.065"	
16	H94997	UNIVERSAL JOINT YOKE	1		
17	JD7760	LUBRICATION FITTING	1	65° X 21.336 MM LONG (0.840" LONG) 65°, 1/8"	
18	E50613	SNAP RING	1		
19	AE30034	CROSS AND BEARING ASSEMBLY	1		
20	19H3131	CAP SCREW	2	5/16" X 2"	
	T16464	LOCK NUT	2	7.925 MM (5/16")	
21	R27899	BUSHING	1		
22	AH93141	UNIVERSAL JOINT YOKE	1		
23	H95100	HUB	1		
24	19H1912	CAP SCREW	1	3/8" X 3-1/2"	
	H99923	LOCK NUT	1	9.525 MM (3/8")	
25	P37172	WASHER	1	25.806 X 38.100 X 1.905 MM (1-1/64" X 1-1/2" X 0.075")	
26	W23122	SNAP RING	1		
27	JD7760	LUBRICATION FITTING	1	65° X 21.336 MM LONG (0.840" LONG)	
28	H94995	PRESSED FLANGED HOUSING	6		

1D8

FC: 5339

POWER TRAIN

MAIN POWERSHAFT SHIELDS AND HOSE HOLDER - CONTINUED

KEY	PART NO.	PART NAME	QTY	SERIAL NO.	REMARKS
1	AH200201	SHIELD	1		
2	AH200145	SHIELD	1		
3	19H1732	CAP SCREW	2	3/8" X 1-1/4"	
	24H1305	WASHER	2	13/32" X 13/16" X 0.065"	
	12H304	LOCK WASHER	2	3/8"	
	14H812	NUT	2	3/8"	
4	19H1765	CAP SCREW	2	3/8" X 1-3/4"	
	24H1305	WASHER	2	13/32" X 13/16" X 0.065"	
	14H812	NUT	2	3/8"	
5	H125860	ISOLATOR	2		
6	AH200200	SHIELD	1		
7	19H1731	CAP SCREW	18	3/8" X 1"	
	12H304	LOCK WASHER	18	3/8"	
	14H812	NUT	18	3/8"	
8	AH200803	BRACKET	1		
9	AH200141	BRACKET	1		
10	AH200827	HOUSING	1		
11	GN11175	DECAL	1	"CAUTION"	
12	E74026	DECAL	2	(SUB E82514) "DANGER" (DRIVE LINE ENTANGLEMENT)	
13	19H1936	CAP SCREW	16	3/8" X 3/4"	
	12H304	LOCK WASHER	16	3/8"	
	14H812	NUT	16	3/8"	
14	AH200003	HOUSING	1		
15	AH200142	BRACKET	1		
16	AH200112	SHIELD	1		
17	19H2038	CAP SCREW	6	3/8" X 1/2"	
	12H304	LOCK WASHER	6	3/8"	
	14H812	NUT	6	3/8"	

1D19

FC: 5916

HYDRAULICS

REEL DRIVE SYSTEM - FRONT AND LEFT-HAND SIDE

KEY	PART NO.	PART NAME	QTY	SERIAL NO.	REMARKS
1	AH130563	HYDRAULIC HOSE	1		3/4" X 2 852 MM (112-1/4") X 13/16", PRESSURE
2	R26375	O-RING	2		
3	AH75167	HYD. QUICK-CONNECT COUPLER	1		
4	AR94522	INTERNAL HALF COUPLER	1		
5	AH130564	HYDRAULIC HOSE	1		3/4" X 2 927 MM (115-1/4") X 1", RETURN
6	H112567	PLATE	2		
7	H122772	CLAMP	4		
8	03M7245	BOLT	2		M8 X 55
	14M7298	FLANGE NUT	2		M8
9	T77857	O-RING	1		
10	AH200522	LINE	1		
11	AH200523	LINE	1		
12	T77932	O-RING	1		
13	AH200310	SUPPORT	3		
14	03H1495	BOLT	4		3/8" X 1-1/2"
	H99923	LOCK NUT	4		9.525 MM (3/8")
15	03H1540	BOLT	6		5/16" X 3/4"
	T16464	LOCK NUT	6		7.925 MM (5/16")
16	AH200514	BRACKET	1		
17	38H1162	ADAPTER	1		
18	R26906	O-RING	1		
19	AH200516	LINE	1		PRESSURE
20	AH200517	LINE	1		RETURN
21	AH200415	CLIP	4		
22	14M7296	FLANGE NUT	2		M10
23	12M7066	LOCK WASHER	2		10.200 MM

1E3

FC: 5921

HYDRAULICS

HEADER LIFT HYDRAULIC LINES AND HOSES - CONTINUED

KEY	PART NO.	PART NAME	QTY	SERIAL NO.	REMARKS
1	R26375	O-RING	3		
2	38H1161	ADAPTER	2		
3	T77857	O-RING	10		
4	AH121605	HYDRAULIC HOSE	2		13/16" X 515 MM (20-1/4") X 13/16"
5	H117937	CLAMP	4		
6	03M7189	BOLT	4		M8 X 45 (RD. HEAD)
	14M7298	FLANGE NUT	4		M8
7	AH131378	OIL LINE	1		
8	03M7280	BOLT	1		M6 X 45 (RD. HEAD)
	14M7303	FLANGE NUT	1		M6
9	H116706	CLAMP	1		
10	03M7262	BOLT	2		M6 X 50 (RD. HEAD)
	14M7303	FLANGE NUT	2		M6
11	H121168	PLATE	4		
12	H108291	CLAMP	8		
13	AH130113	HYDRAULIC LINE	1		
14	38H1206	TEE FITTING	1		
15	19M8317	SCREW	1		M8 X 40
	14M7298	FLANGE NUT	1		M8
16	H135974	BRACKET	1		
17	19M8318	SCREW	1		M8 X 45
	14M7298	FLANGE NUT	1		M8
18	AH131576	HYDRAULIC LINE	1		
19	H131115	BRACKET	1		
20	38H1017	TEE FITTING	1		
21	AH128753	HYDRAULIC LINE	1		
22	38H1173	ADAPTER	1		
23	R26448	O-RING	1		
24	03M7184	BOLT	4		M8 X 20 (RD. HEAD)
	14M7396	LOCK NUT	4		M8

1E12

FC: 5931

HYDRAULICS

CYLINDER SPEED HYDRAULIC LINES AND HOSES - CONTINUED

KEY	PART NO.	PART NAME	QTY	SERIAL NO.	REMARKS
1	19M8317	SCREW	6		
	14M7298	FLANGE NUT	6		M8 X 40
2	H127589	CLAMP	12		M8
3	AH127892	HYDRAULIC LINE	1		
4	T77613	O-RING	3		
5	AH128853	HYDRAULIC LINE	1		
6	R26448	O-RING	1		
7	AH130629	FITTING	1		
8	AH128640	HYDRAULIC LINE	1		
9	T77814	O-RING	2		
10	AH128639	HYDRAULIC HOSE	1		9/16" X 410 MM (16-1/4") X 9/16"

1E21

FC: 5921

HYDRAULICS

SOLENOID CONTROL VALVE KIT FOR CYLINDER SPEED POPPET
 HP2940 -UN-01JAN94

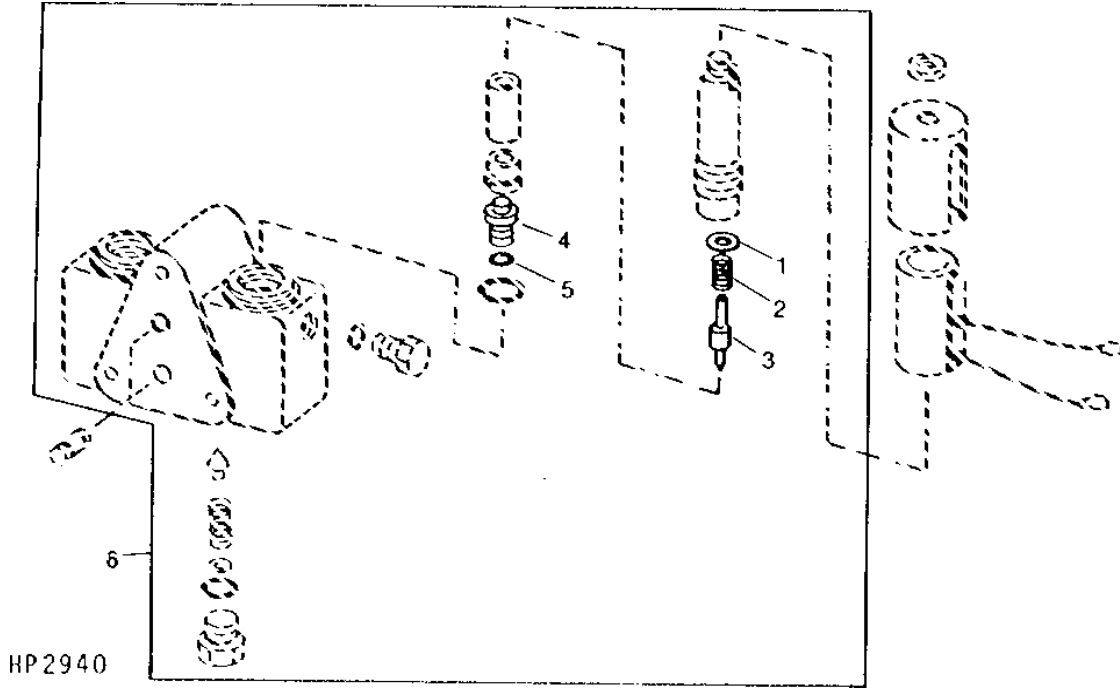

KEY	PART NO.	PART NAME	QTY	SERIAL NO.	REMARKS
1	WASHER	1		
2	E62089	SPRING	1		
3	POPPET	1		
4	ORIFICE	1		
5	U40962	O-RING	1		
6	AH131420	SEAT KIT	1		POPPET

1F5

FC: 5921

HYDRAULICS

SOLENOID CONTROL VALVE MODULE ASSEMBLY AND MOUNTINGS - CONTINUED

KEY	PART NO.	PART NAME	QTY	SERIAL NO.	REMARKS
1	R77175	COVER	1		
2	AH125760	HYD. QUICK-CONNECT COUPLER	1		
3	R26448	O-RING	1		
4	14H786	NUT	6	1/4"	
5	12H297	LOCK WASHER	6	1/4"	
6	E62892	STUD	3	1/4" X 11-3/4" 1/4" X 11-3/4"	(CUT TO LENGTH)
7	H139513	BRACKET	1		
8	AH131405	SEAL	2		
9	AH131326	SEAL	8		(WITH 5 MODULES-USE 9; WITH 4 MODULES-USE 7)
10	AH131461	SOLENOID VALVE	1		AUGER SWING, (SUB AZ47075)
	AZ47075	VALVE	1		
11	AH137199	VALVE	1		CYLINDER SPEED, (SUB AH139062, E62917, H145052 AND 38H1309)
	AH139062	VALVE	1		
12	AH131404	VALVE	1		(HEADER LIFT) (SUB AH142450)
13	AH137198	VALVE	1		VALVE PORT
14	H139512	BRACKET	1		
16	H135776	ORIFICE	2		1.06MM DIA.
17	R77464	PIN CONTACT	AR		(PACKAGE OF 50)
18	AH124731	ELECTRICAL COIL	7		(WITH 5 MODULES-USE 9; WITH 4 MODULES-USE 7)
19	E62942	COVER	7		(WITH 5 MODULES-USE 9; WITH 4 MODULES-USE 7)
20	H135898	COVER	1		
21	A4655R	NUT	7		(WITH 5 MODULES-USE 9; WITH 4 MODULES-USE 7)
22	57M7199	PIN CONTACT	1		(24 WAY)
23	21H1290	SCREW	4		0.138" X 1/2"
	14H1026	NUT	4		0.138"
24	H139515	MANIFOLD	2		
25	AH134733	SEAL	2		
26	R26375	O-RING	1		
27	R39112	FITTING	1		
28	AH137200	VALVE	1		UNLOADING AUGER ENGAGE
29	AH200250	VALVE	1		(SUB AH139061) (5 MODULES) REMANUFACTURED
	AH139061	VALVE STACK	1		

1F14

FC: 5933

HYDRAULICS

UNLOADING AUGER SWING CYLINDER AND MOUNTING - CONTINUED

KEY	PART NO.	PART NAME	QTY	SERIAL NO.	REMARKS
1	H137225	END	1		
2	W13288	NUT	1		
3	RING	1	(KIT AH129245)	
4	SNAP RING	1	(KIT AH129245)	
5	SEAL	1	(KIT AH129245)	
6	SEAL	1	(KIT AH129245)	
7	WASHER	1	(KIT AH129245)	
8	O-RING	1	(KIT AH129245)	
9	BEARING	1		
10	H135154	ROD	1		
11	O-RING	1	(KIT AH129245)	
12	RING	1	(KIT AH129245)	
13	PISTON	1		
14	LOCK NUT	1		
15	HYDRAULIC CYLINDER BARREL	1		
16	AH132210	HYDRAULIC CYLINDER	1		
17	R56930	PIN	1		
18	11H218	COTTER PIN	1	3/16" X 1-1/2"	

1F24

FC: 5441

SEPARATOR SHELL

ACCESS DOOR AND SIDE PANELS

KEY	PART NO.	PART NAME	QTY	SERIAL NO.	REMARKS
1	19M7785	SCREW	2	M10 X 25	
	14M7296	FLANGE NUT	2	M10	
2	H200343	BRACKET	1		
3	AH200262	PANEL	1		
4	H200372	BRACKET	1		
5	H200342	BRACKET	1		
6	03M7184	BOLT	7	M8 X 20	
	14M7298	FLANGE NUT	7	M8	
7	19M7865	SCREW	4	M8 X 16	
	14M7298	FLANGE NUT	4	M8	
8	19M7866	SCREW	4	M8 X 20	
9	AH126015	PANEL	1		
10	H130968	ANGLE	2		
11	03M7185	BOLT	4	M8 X 25	
	14M7298	FLANGE NUT	4	M8	
12	14M7296	FLANGE NUT	1	M10	
13	H200373	BRACKET	1		
14	AH125574	DOOR	1	(SUB AH133830)	
15	H200346	SUPPORT	1		
16	H200347	SUPPORT	1		
17	H200379	BRACE	1		
18	19M7866	SCREW	4	M8 X 20	
	14M7298	FLANGE NUT	4	M8	

1G10

FC: 5659

SEPARATOR SHELL

AUGER DRIVE SHIELDS (R.H. SIDE) - CONTINUED

KEY	PART NO.	PART NAME	QTY	SERIAL NO.	REMARKS
1A	H128884	SHIELD	1	-635400	
1B	H141772	SHIELD	1	635401-	
2	19M3131	CAP SCREW	2		M8 X 25
	14M7298	FLANGE NUT	2		M8
3	H135860	SHIELD	1	-640400	AUGER DRIVE IDLER
4	19M7865	SCREW	3	-640400	M8 X 16, (INTO WELDNUTS)
5	19M7865	SCREW	4		M8 X 16
	14M7298	FLANGE NUT	4		M8
6	AH135633	SHIELD	1		AUGER DRIVE
7	14M7299	FLANGE NUT	1		M12
8	H134383	SHIELD	1	-640400	(SUB H141770) SHOE DRIVE
	H141770	SHIELD	1		
9	03M7184	BOLT	2		M8 X 20
	14M7298	FLANGE NUT	2		M8
10	H134414	STRAP	1	-640400	
	H143331	STRAP	1	640401-	(SUB H146756)
11	03M7183	BOLT	2		M8 X 16
	14M7298	FLANGE NUT	2		M8
..	H141771	SUPPORT	1		

1G19

FC: 5659

SEPARATOR SHELL

R.H. GULL WING DOORS - CONTINUED

KEY	PART NO.	PART NAME	QTY	SERIAL NO.	REMARKS
1	AH125306	CHANNEL	1		
2	14M7296	FLANGE NUT	10	M10	
3	19M7784	SCREW	10	M10 X 20	
4	H125537	PLATE	2		
5	H139056	BRACKET	2		
6	14M7298	FLANGE NUT	4	M8	
7	AH128596	SPRING	2		
	AH143219	SPRING	2		
8	H135965	STOP	1		
9	AH127716	DOOR	1		
10	M68701	GROMMET	1		
11	H130039	DEFLECTOR	1		
12	H132822	ANGLE	2		
13	H143453	FOAM PAD	2		
14	H143454	BRACKET	2		
15	37M7083	SCREW	4	M8 X 12	

1H4

FC: 5263

SEPARATOR SHELL

LEFT-HAND LANDING AND LADDER - CONTINUED

KEY	PART NO.	PART NAME	QTY	SERIAL NO.	REMARKS
1	AH200520	HANDRAIL	1		
2	AH200576	BRACKET	1		
3	14H809	NUT	2	1/2", (SUB 14H1040)	
	14H1040	NUT	2	1/2"	
4	12H301	LOCK WASHER	2	1/2"	
5	24H1111	WASHER	2	17/32" X 1-1/16" X 0.090"	
6	AH200435	SUPPORT	1		
7	AH200437	SUPPORT	1		
8	19H1733	CAP SCREW	2	3/8" X 2-1/2"	
	24H1305	WASHER	4	13/32" X 13/16" X 0.065"	
	H99923	LOCK NUT	2	9.525 MM (3/8")	
9	AH200441	GUARD	1		
10	03H1709	BOLT	4	5/16" X 1"	
	24H1136	WASHER	4	11/32" X 11/16" X 0.065"	
	12H303	LOCK WASHER	4	5/16"	
	14H785	NUT	4	5/16"	
11	AH200677	LADDER	1		
12	19H2021	CAP SCREW	5	3/8" X 5/8"	
	12H304	LOCK WASHER	5	3/8"	
	14H812	NUT	5	3/8"	
13	H65108	SCREW	4	7.938 X 12.700 MM (5/16" X 1/2") (SUB H78354)	
14	AH200678	SUPPORT	1		
15	19H1721	CAP SCREW	2	1/2" X 1-1/2"	
	24H1111	WASHER	2	17/32" X 1-1/16" X 0.090"	
	U12622	LOCK NUT	2	12.700 MM (1/2") (SUB BP12214)	

1H14

FC: 5173

FEEDER HOUSE

FEEDER HOUSE FRAME - CONTINUED

KEY	PART NO.	PART NAME	QTY	SERIAL NO.	REMARKS
1	19M7814	SCREW	4		
2	H93556	CLAMP	2		
3	H136013	MAT	2		
4	H133843	STRAP	4		
5	H141835	REINFORCEMENT	2		
6	H136015	MAT	4		
7	AH125514	FRAME	1		(SUB AH137831)
8	03M7192	BOLT	4		M10 X 30
9	H134896	ANGLE	2		
10	03M7190	BOLT	1		M10 X 20, (SUB H75985)
11	H123636	DEFLECTOR	1		
12	H141713	WEAR PLATE	2		(SUB H141713)
13	19M7784	SCREW	6		M10 X 20
14	14M7296	FLANGE NUT	6		M10
15	124424	SPRING	2		
16	H134140	BOLT	2		
17	H130826	PIN	2		
18	14M7296	FLANGE NUT	4		
19	H123637	DEFLECTOR	1		
20	H141713	WEAR PLATE	2		FIXED SPEED
21	H123638	EXTENSION	2		RICE OPT.- REQUIRES TWO MORE H134896
22	03M7191	BOLT	4		M10 X 25, REMOVED, THIS APPLICATION ONLY
23	03M7190	BOLT	4		M10 X 20
24	H87765	STRIPPER	2		(SUB H141713) REMOVED, THIS APPLICATION ONLY
	H141713	WEAR PLATE	2		
25	H123633	SHIELD	1		

1H24

FC: 5173

FEEDER HOUSE

FEEDER HOUSE FLOOR - CONTINUED

KEY	PART NO.	PART NAME	QTY	SERIAL NO.	REMARKS
1	AH128073	FLOOR	1	-640400	
	AH137733	FLOOR	1	640401-	
2	03M7190	BOLT	8		M10 X 20
3	H131452	SEAL	1		
4	14M7296	FLANGE NUT	8		M10
5	19M7895	SCREW	6		M20 X 50
6	14M7300	FLANGE NUT	6		M20
7	19M7789	SCREW	20		M12 X 30
8	14M7299	FLANGE NUT	20		M12
9	AH128239	SUPPORT	1		(SUB AH140113)
	AH140113	SUPPORT	1		
10	AH141780	SUPPORT	1	640401-	
11	AH141782	ARM	1	640401-	
12	AH141781	ARM	1	640401-	
13	H97322	CAM	1	640401-	
14	14M7299	FLANGE NUT	4	640401-	M12
15	19M7790	SCREW	1	640401-	M12 X 35
16	AH131303	PAN	1		
17	19M7865	SCREW	2		M8 X 16
18	14M7298	FLANGE NUT	2		M8
19	19M7784	SCREW	2		M10 X 20
20	AH89557	CLIP	1		
21	14M7296	FLANGE NUT	2		M10

1110

FC: 5276

FEEDER HOUSE

REVERSER ACTUATOR - CONTINUED

KEY	PART NO.	PART NAME	QTY	SERIAL NO.	REMARKS
1	AH200412	SPRING ASSEMBLY	1		
2	34H294	SPRING PIN	1		7/32" X 3/4"
3	H35481	PIN	1		4.928 X 25.400 MM (0.194" X 1")
4	11H267	COTTER PIN	1		1/16" X 3/4", (SUB 11M6686)
	11M6686	COTTER PIN	1		1.600 X 25 MM (0.063" X 0.984")
5	AH200413	COUPLING	1		
6	19H1898	CAP SCREW	2		1/4" X 1-1/2"
	M40333	LOCK NUT	2		6.350 MM (1/4")
7	AH200643	ACTUATOR	1		
8	14H809	NUT	1		1/2", (SUB 14H1040)
	14H1040	NUT	1		1/2"
9	12H301	LOCK WASHER	3		1/2"
10	AH200779	PLATE	1		
11	AH200429	BRACKET	1		
12	19H1815	CAP SCREW	1		1/2" X 1-1/4"
13	19H1777	CAP SCREW	1		1/2" X 1-3/4"
14	24H1111	WASHER	1		17/32" X 1-1/16" X 0.090"

2A25

FC: 5652

SEPARATOR

CYLINDER DOOR - CONTINUED

KEY	PART NO.	PART NAME	QTY	SERIAL NO.	REMARKS
1	H134160	SUPPORT	1	(SUB H148063)	
	H148063	SUPPORT	1		
2	14M7298	FLANGE NUT	24	M8	
3	H134157	SEAL	1	(SUB H148061)	
4	14M7396	LOCK NUT	2	M8	
5	24M7207	WASHER	2	8.400 X 24 X 2 MM	
6	H134654	HANDLE	2		
7	03M7247	BOLT	2	M10 X 90	
8	14M7296	FLANGE NUT	4	M10	
9	H134165	SUPPORT	1		
10	E50096	BUSHING	2		
11	19M7944	SCREW	2	M10 X 120	
12	03M7185	BOLT	8	M8 X 25	
13	AH130202	DOOR	1		
14	H134154	REINFORCEMENT	1		
15	H134163	SEAL	1		
16	H134151	ISOLATOR	1		
17	03M7183	BOLT	16	M8 X 16	
18	H134164	SUPPORT	1		

2B10

FC: 5773

SEPARATOR

CONCAVE INDICATOR AND BRACKETS - CONTINUED

KEY	PART NO.	PART NAME	QTY	SERIAL NO.	REMARKS
1	AH200506	ARM	1		
2	24H1136	WASHER	6		8.738 X 17.475 X 1.651 MM
3	AH133156	CAM	1		
	11M7081	COTTER PIN	3		2.500 X 20 MM (0.098" X 0.787")
4	AH200509	LINK	1		(SUB H146389)
5	AH200820	GUARD	1		FOR REAR OF CONCAVE
6	AH200505	DECAL	1		
7	14H785	NUT	4		7.925 MM (5/16")
8	12H303	LOCK WASHER	4		7.938 MM (5/16")
9	03H1540	BOLT	2		7.925 X 19.050 MM (5/16" X 3/4")
10	AH200486	COVER	1		APPLY ON 03M7218 (6 ML HIGH-STRENGTH)
11	AH200504	BRACKET	1		FOR BOTTOM FRONT OF CONCAVE
12	19H1900	CAP SCREW	2		7.925 X 19.050 MM (5/16" X 3/4") USE ONE PER H134773

CLICK HERE TO **DOWNLOAD** THE COMPLETE MANUAL

- Thank you very much for reading the preview of the manual.
- You can download the complete manual from: www.heydownloads.com by clicking the link below



- Please note: If there is no response to CLICKING the link, please download this PDF first and then click on it.

CLICK HERE TO **DOWNLOAD** THE COMPLETE MANUAL

2B20

FC: 5886

SEPARATOR

CLEANING FANS AND SHROUDS - CONTINUED

KEY	PART NO.	PART NAME	QTY	SERIAL NO.	REMARKS
1	19M7867	SCREW	AR	M8 X 25	
2	AH126214	AIR DUCT	1		
3	14M7298	FLANGE NUT	AR	M8	
	AH126213	AIR DUCT	1		
4	AH125692	HOUSING	4		
5	19M7865	SCREW	AR	M8 X 16	
6	AH128618	DIFFUSER	4		
7	19M7818	SCREW	AR	M12 X 80	
8	19M7866	SCREW	AR	M8 X 20	
9	14M7396	LOCK NUT	AR	M8	
10	28H2611	SPACER	18	0.546" X 0.840" X 2"	
11	14M7299	FLANGE NUT	AR	M12	
12	19M7789	SCREW	4	M12 X 30	
13	AH128307	SUPPORT	1		
14	H134996	PLATE	1	(FOR CORN AND GRAIN ONLY)	
	H134996	PLATE	1	(FOR CORN AND GRAIN ONLY)	
	H137389	PLATE	1	(FOR RICE ONLY)	
15	19M7898	SCREW	4	M10 X 130	
16	19M8039	SCREW	AR	M8 X 80	
17	AH130477	AIR DUCT	1		
18	19M7800	SCREW	2		
..	H143594	COVER	3	(SUB AH138384)	
..	AH138384	MOUNTING PARTS	1		

2C6

FC: 5882

SEPARATOR

CHAFFER EXTENSION ELEMENT - CONTINUED

KEY	PART NO.	PART NAME	QTY	SERIAL NO.	REMARKS
1	AH127469	LOUVER	12		SEMI-DEEP TOOTH LOUVER
2	H132293	LEAF SPRING	2		
3	H132290	STRIP	2		
4	AH130189	STRIP	1		SEMI-DEEP TOOTH LOUVER
5	H110178	SCREW	1		
6	H126933	WASHER	1		
7	AH122080	LINK	1		
8	H126934	WASHER	2		
9	H126932	NUT	1		
10	AH127435	CHAFFER	1		SEMI-DEEP TOOTH LOUVER
	AH130996	CHAFFER	1		FIXED LOUVER
11	H132160	FINGER	2		
12	19M7866	SCREW	4		M8 X 20
13	14M7396	LOCK NUT	4		M8
14	AH131213	HANDLE	1		(SUB H149997)
15	19M7785	SCREW	4		M10 X 25
16	24H1308	WASHER	4		13/32" X 1" X 0.134"

2C16

FC: 5871

SEPARATOR

STRAW WALKERS (-1990) - CONTINUED

KEY	PART NO.	PART NAME	QTY	SERIAL NO.	REMARKS
1	AH128735	SEAL	2		OUTSIDE WALKERS ONLY
2	H135225	STRIP	AR		BETWEEN WALKERS ONLY, (SUB H135923)
	H135923	STRIP	AR		
3	H131516	RISER	1		ONE PER WALKER EXCEPT R.H. OUTSIDE WALKER, (GRAIN)
4	14M7303	FLANGE NUT	3		M6
5	H131604	SEAL	2		OUTSIDE WALKERS ONLY
6	H131608	SEAL	2		OUTSIDE WALKERS ONLY
7	H131607	SEAL	2		OUTSIDE WALKERS ONLY
8	AH128530	STRAW WALKER	4	-FEB90	(SUB AH135380, (4) H140677, (2) H141313, (4) H141314, (8) 03M7192, (4) 03M7267, (8) 14M7400, (4) 14M7396) (USE H87268 W/LOSS MONITOR)
	AH135380	STRAW WALKER	4		
9	03M7251	BOLT	3		M6 X 12
10	03M7190	BOLT	1		M10 X 20
11	14M7298	FLANGE NUT	1		
12	H140019	RETAINER	1	-FEB90	(SUB AH136572) ON REAR BEARINGS ONLY
13	14M7296	FLANGE NUT	2		M10 ON REAR BEARINGS ONLY
14	H140070	BEARING	16	-FEB90	(SUB AH136572)
15	H140074	PLATE	2	-FEB90	(SUB AH136572)
16	14M7400	LOCK NUT	8		M10
17	H140072	PLATE	2	-FEB90	
18	H131661	PAN	1		
19	14M7396	LOCK NUT	2		M8 WITH EXTENSION PAN ONLY
	H131531	NUT	2	-JUL93	8 MM (0.315") (SUB M84309) RETAINS M8 BOLTS BEFORE EXTENSION PAN INSTALL
	M84309	NUT	2		7.925 MM (5/16")
20	03M7184	BOLT	AR		M8 X 20 WITH EXTENSION PAN ONLY
21	H85233	RIVET	2		4.750 MM
22	03M7333	BOLT	4		M10 X 110
23	03M7221	BOLT	AR		M6 X 16
24	H139667	STRAP	16		(SUB AH136572)
25	H128082	WASHER	1	-645400	
	H143615	REINFORCEMENT	1		
26	24H1292	WASHER	AR		11/32" X 3/4" X 0.120"
27	H140218	FLAP	4		
28	H141883	RISER	1		
29	19M7865	SCREW	1		M8 X 16
..	AH136572	BEARING	1		SUB. TO: (1) H140677 BEARING OR (1) H146078 PLATE OR (1) H141313 COVER OR (1) H141314 RETAINER AS REQUIRED

BH79481 (COMPLETE GOODS) CENTER RISERS

BH78364 (COMPLETE GOODS) STRAW WALKER FLAPS

2D2

FC: 5842

SEPARATOR

SPREADER CURTAIN - CONTINUED

KEY	PART NO.	PART NAME	QTY	SERIAL NO.	REMARKS
1	H131865	PIN	2		
2	11H229	COTTER PIN	2		
3	AH135658	LIMIT CURTAIN	1		3/32" X 2", (SUB 11M7086)
4	H135209	BRACKET	2		
	19M7865	SCREW	2		M8 X 16
	14M7298	FLANGE NUT	2		M8

2D12

FC: 5731

SEPARATOR

DUAL-RANGE LOCKOUT ARM - CONTINUED

KEY	PART NO.	PART NAME	QTY	SERIAL NO.	REMARKS
1	H139709	RETAINER	1		
2	19M7867	SCREW	2		M8 X 25
3	M45123	EXTENSION SPRING	1		
4	AH80384	ISOLATOR	1		
	AH143746	RUBBER MOUNT	1	MAR94-	
5	AH131070	ARM	1		(SUB AH143747)
	AH143747	ARM	1		
6	H110542	PIN	1		
7	19M7826	SCREW	1		M16 X 70
8	03M7184	BOLT	1		M8 X 20
9	14M7291	FLANGE NUT	1		M16
10	AH139180	KIT	1		
11	M63707	LOCK NUT	3		6.350 MM
12	H127732	GUIDE	1		
13	14M7298	FLANGE NUT	1		M8
14	19H2151	CAP SCREW	3		1/4" X 3", SHEAR BOLTS
15	H114001	QUICK LOCK PIN	1		
16	34M7036	SPRING PIN	1		5 X 45 MM
17	H200149	ANGLE	1		

2D22

FC: 5833

SEPARATOR

SECONDARY COUNTERSHAFT DRIVE - CONTINUED

KEY	PART NO.	PART NAME	QTY	SERIAL NO.	REMARKS
1	H128010	BELT	1		
2	AH124826	STUD	1		
3	B10604	SPRING	1		
4	H97513	BUSHING	1		
5	24H1625	WASHER	1	17/32" X 1" X 0.120"	
6	11M7028	COTTER PIN	1	5 X 32 MM	
7	24M7047	WASHER	2	13 X 24 X 2.500 MM	
8	H133667	CLEVIS	1		
9	H748DA	PIN	1		
10	19M7824	SCREW	1	M16 X 60	
11	AH97031	SHEAVE	1		
12	14M7291	FLANGE NUT	1	M16	
13	P46402	SNAP RING	1		
14	24M7091	WASHER	1	26 X 44 X 4 MM	
15	AA5607R	SEAL	2		
16	H99147	BUSHING	2		
17	AH124828	ARM	1		
18	H129207	PIVOT	1		
19	14M7275	NUT	2	M12	
20	AH104783	PULLEY	1		
21	AH109197	PIN	1		
22	H129101	SHEAVE	1	-640400	
	H142143	SHEAVE	1	640401-	
23	19M7784	SCREW	3	M10 X 20	

2E8

FC: 5838

SEPARATOR

SEPARATOR FAN DRIVE - CONTINUED

KEY	PART NO.	PART NAME	QTY	SERIAL NO.	REMARKS
1	19M7786	SCREW	1	M10 X 30	
2	24H1314	WASHER	1	13/32" X 1-3/4" X 7/64"	
3	AH124050	THROW-OUT BEARING	1		
4	AH127496	SHEAVE	1	401 MM O.D.(750-1350 RPM)	
	AH131979	SHEAVE	1	289 MM O.D. (490-980 RPM) OPT.	
5	JD7759	LUBRICATION FITTING	2		
6	AH14080	SEAL	4		
7	H132298	SHEAVE	1	401 MM O.D. (750-1350 RPM) (SUB AH134873)	
	H137266	SHEAVE	1	289 MM O.D. (490-980 RPM) OPT.	
8	19M8112	SCREW	1	M12 X 55	
9	24H1512	WASHER	8	1-13/32" X 2" X 0.032"	
10	26M6787	SHAFT KEY	1	10 X 32 MM	
11	AH129420	PRESSED FLANGED HOUSING	1		
12	JD39104	BALL BEARING	1		
	AH139296	BALL BEARING	1		
13	H135410	PRESSED FLANGED HOUSING	1		
14	14M7296	FLANGE NUT	3	M10	
15	JD7846	LUBRICATION FITTING	1		
16	03M7191	BOLT	3	M10 X 25	
17	22M7081	SET SCREW	1	M10 X 10	
18	AH133191	ECCENTRIC LOCKING COLLAR	1		
19	H132208	JACKSHAFT	1		
20	14M7299	FLANGE NUT	1	M12	
21	H140404	BELT	1	631211-	(750-1350 RPM) STD. SPEED
	H137264	BELT	1		(490-980 RPM) OPT. SPEED
22	H100796	SPRING PIN	2		
23	26M6731	SHAFT KEY	1	WOODRUFF	
24	14M7396	LOCK NUT	4	M8	
25	H135599	WASHER	1		
26	H93399	SPRING	4		
27	H133489	BUSHING	4		
28	AH131248	SHEAVE	1		
29	H138435	SET SCREW	2	M10 X 25	
30	14M7152	NUT	2	M10	
31	AH131249	SHEAVE	1		
32	19M7873	SCREW	4	M8 X 110	
33	24H1307	WASHER	AR	13/32" X 1" X 1/16"	
34	H137817	STRIPPER	1		
35	14M7397	LOCK NUT	6	M6	
36	H137815	CLAMP	6		
37	19M7862	SCREW	6	M6 X 20	
38	AH134873	SHEAVE	1	(INCLUDES KEYS 7, 8 AND 20)	
..	AH138893	KIT	1	-640400	(SUB (2) H137817)
..	AH138895	KIT	1	-640400	(SUB (2) H137817)
..	H137817	STRIPPER	2		

2E18

FC: 5181

SEPARATOR

REEL / BELT PICKUP CHARGE PUMP MOUNTING AND SHEAVE - CONTINUED

KEY	PART NO.	PART NAME	QTY	SERIAL NO.	REMARKS
1	H128098	ARM	1		
2	03M7185	BOLT	1		M8 X 25
3	19M7865	SCREW	4		M8 X 16 (NOT FOR USE WITH MUDSHIELD)
4	H78340	STRAP	1		
5	24M7207	WASHER	2		8.400 X 24 X 2 MM
6	14M7298	FLANGE NUT	4	-FEB94	M8
	14M7396	LOCK NUT	2	FEB94-	M8
7	H128111	BRACKET	1		NOT FOR USE WITH MUDSHIELD
8	19M7867	SCREW	1		M8 X 25
9	JD10312	BALL BEARING	1		
10	E59406	FLANGE NUT	1		3/8"
11	H132937	SHEAVE	1		
12	03M7186	BOLT	2		M8 X 30
13	BP13616	SNAP RING	1		
14	B2984R	PLUG	1		
15	AZ20216	BALL BEARING	1		(SUB JD10035)
16	H132938	HUB	1		
17	19M7785	SCREW	4		M10 X 25
18	JD7788	LUBRICATION FITTING	1		

2F4

FC: 5841

SEPARATOR

STRAW CHOPPER DECK, SUPPORTS AND FINS - CONTINUED

KEY	PART NO.	PART NAME	QTY	SERIAL NO.	REMARKS
1	H126335	PIPE	1		
2	H126334	LOCK WASHER	2		
3	14M7400	LOCK NUT	2		
4	19M7835	SCREW	2		M10
5	AH135721	SHEET	1	-640400	M10 X 35 (SUB AH138891)
	AH138891	SHEET	1		
6	H126336	PIPE	1		
7	AH125999	SUPPORT	1	-640400	(SUB AH137792)
	AH137792	SUPPORT	1		
8	H130949	VANE	1		
9	H114535	VANE	1		
10	H114537	VANE	2		
11	H144288	DECAL	2	-SEPT94	(SUB H149102) "WARNING" CHOPPER POSITION
	H149102	DECAL	2		"WARNING" CHOPPER POSITION
12	24M7207	WASHER	1		8.400 X 24 X 2 MM
13	03M7183	BOLT	2		M8 X 16
	E64256	LOCK NUT	2		M8
14	H114538	VANE	2		
15	H114536	VANE	1		
16	H130948	VANE	1		
17	03M7191	BOLT	2		M10 X 25
18	19M7167	CAP SCREW	2		M10 X 25
19	14M7298	FLANGE NUT	2		M8
20	03M7184	BOLT	2		M8 X 20
21	H128124	BRACKET	1		
22	14M7400	LOCK NUT	1		M10
23	14M7296	FLANGE NUT	1		M10
24	11M7009	COTTER PIN	1		2 X 16 MM (0.079" X 0.630")
25	24M7238	WASHER	1		8.700 X 17 X 2 MM (0.343" X 0.669" X 0.079")
26	45M7044	PIN	1		8 X 16 MM (0.315" X 0.630")

2F14

FC: 5841

SEPARATOR

STRAW CHOPPER HOUSING AND KNIFEBANK - CONTINUED
(640401-)

KEY	PART NO.	PART NAME	QTY	SERIAL NO.	REMARKS
1	AH138156	SHEET	1		L.H.
2	19M7866	SCREW	AR		M8 X 20
3	19M7785	SCREW	4		M10 X 25
4	11M7059	COTTER PIN	2		3.200 X 20 MM
5	14M7298	FLANGE NUT	AR		M8
6	24H1341	WASHER	2		17/32" X 15/16" X 0.060"
7	B28970	SPRING	2		
8	H136179	PIN	2		
9	H149026	SUPPORT	1		R.H.
	H149027	SUPPORT	1		L.H.
10	AH138157	SHEET	1		R.H.
11A	H141138	PIN	1	-AUG93	(SUB H149992)
11B	H149992	PIN	1	AUG93-	
12	AH140129	CHANNEL	1		
13	H142141	KNIFE	1		
14	03M7184	BOLT	AR		M8 X 20
15	H146308	SHIELD	1		
16	AH139791	SHEET	1		
17	H144288	DECAL	2	-SEPT94	(SUB H149102) "WARNING" CHOPPER POSITION
	H149102	DECAL	2		"WARNING" CHOPPER POSITION
18	H145857	LABEL	1		"IMPORTANT" CHOPPER POSITION
	H145858	LABEL	1		"WARNING" CHOPPER POSITION (FRENCH)
19	AH139680	SUPPORT	1		L.H.
20	AH139679	SUPPORT	1		R.H.
21A	11M7059	COTTER PIN	2	-AUG93	3.200 X 20 MM
21B	H114001	QUICK LOCK PIN	2	AUG93-	
22	H145778	RAIL	1		
23	AH138155	SHEET	1	-SEPT93	(SUB AH143048)
	AH143048	SHEET	1		

BH80127 (COMPLETE GOODS) STRAW CHOPPER WITH DRIVES

2F24

FC: 5842

SEPARATOR

STRAW SPREADER - CONTINUED

KEY	PART NO.	PART NAME	QTY	SERIAL NO.	REMARKS
1	AH14097	SHEAVE	1		
2	28H1600	SPACER	1		
3	19M7819	SCREW	1	M12 X 90	
4	AM103480	IDLER	1		
5	19M7825	SCREW	1	M16 X 65	
6	P44439	PRESSED FLANGED HOUSING	14		
7	JD8665	BALL BEARING	1		
8	H135493	SUPPORT	3		
9	03H1540	BOLT	20	5/16" X 3/4"	
10	14H785	NUT	8	5/16"	
11	JD8554	ECCENTRIC LOCKING COLLAR	4		
12	H91228	GEAR	2	(SUB AH139115)	SET OF TWO GEARS
13	19M7572	CAP SCREW	2	M10 X 45	
	14M7296	FLANGE NUT	2	M10	
14	M2300T	CLAMP	2	-640400	(SUB H145112)
	H145112	CLAMP	2		
15	H91796	GEAR	2	(SUB AH139115)	SET OF TWO GEARS
16	24H1433	WASHER	2	29/32" X 2-1/4" X 1/4"	
17	JD9442	BALL BEARING	4		
18	JD8563	ECCENTRIC LOCKING COLLAR	4		
19	AH131166	SUPPORT	2		
20	H64374	SHAFT KEY	3		
21	H134716	DRIVE SHAFT	1		
22	25H1182	GROOVE PIN	2		
23	H135494	PIN	2		
24	19M8318	SCREW	2	M8 X 45	
	14M7396	LOCK NUT	2	M8	
25	37M7058	SCREW	6	M8 X 20	
26	H83795	GUARD	2		
27	AH131165	PLATE	2	-FEB92	(SUB AH141184)
	AH141184	CAP	2		
28	H76933	BLADE	6		
29	24M7207	WASHER	12	8.400 X 24 X 2 MM	
30	19M7322	CAP SCREW	12	-AUG94	M8 X 35
	14M7396	LOCK NUT	12	M8	
31	24M7238	WASHER	10	8.700 X 17 X 2 MM	
32	H128234	BELT	1		
33	14M7291	FLANGE NUT	1	M16	
34	H127583	EYEBOLT	1		
35	24H1772	WASHER	1	21/32" X 1" X 0.105", (SUB 24H1365)	THIS APPLICATION ONLY
	24H1365	WASHER	1	21/32" X 1" X 0.090"	
36	Z33404	SPACER	1		
37	28H2514	BUSHING	1		
38	14M7299	FLANGE NUT	1	M12	
39	14M7291	FLANGE NUT	1	M16	
40	H135017	BRACKET	1		
41	AH130964	SHEAVE	2		
42	H138435	SET SCREW	4		
43	14M7152	NUT	1	M10	

BH80073 (COMPLETE GOODS) STRAW CHOPPER LOWER W/CHAFF SPREADER
 BH80007 (COMPLETE GOODS) STRAW SPREADER W/DRIVES

2G10

FC: 5835

SEPARATOR

CHOPPER DRIVE IDLER - CONTINUED

KEY	PART NO.	PART NAME	QTY	SERIAL NO.	REMARKS
1	AH200238	BASE	1		
2	19H1905	CAP SCREW	2	5/16" X 1"	
	24H1136	WASHER	2	11/32" X 11/16" X 0.065"	
	12H303	LOCK WASHER	2	5/16"	
	14H785	NUT	2	5/16"	
3	AH200231	PIN	1		
4	19H1801	CAP SCREW	1	3/8" X 2"	
	24H1305	WASHER	2	13/32" X 13/16" X 0.065"	
	K40003	LOCK NUT	1	9.525 MM (3/8")	
5	14H760	NUT	8	5/8"	
6	AH200234	STUD	1		
7	AH200205	SUPPORT	1		
8	19H1905	CAP SCREW	5	5/16" X 1"	
	12H303	LOCK WASHER	5	5/16"	
	14H785	NUT	5	5/16"	
9	AH200135	SHEAVE	1		
10	JD7798	LUBRICATION FITTING	1		
11	AH200232	SPACER	1		
12	AH200136	BALL BEARING	2		
13	40M7044	SNAP RING	2		
14	AH200239	BRACKET	1		
15	24M7091	WASHER	4	26 X 44 X 4 MM	
16	AA5607R	SEAL	2		
17	H99147	BUSHING	2		
18	AH200225	ARM	1		
19	AH200233	STUD	1		
20	24H1106	WASHER	2	11/16" X 1-3/4" X 0.134"	
21	N130666	LOCK NUT	1	25.400 MM (1") (SUB MG514101)	

2G20

FC: 5912

SEPARATOR

CHAFF SPREADER PUMP - CONTINUED

KEY	PART NO.	PART NAME	QTY	SERIAL NO.	REMARKS
1	E61791	BOLT	8		7.925 X 69.850 MM (5/16" X 2-3/4")
2	M41029	SNAP RING	1		(KIT AH131176)
3	AH131842	SEAL	1		
4	M48869	WASHER	1		(KIT AH131176)
5	PLATE	1		(SUB AH134555)
6	SEAL	1		(KIT AH131176)
7	GASKET	1		(KIT AH131176)
8	GASKET	1		(KIT AH131176)
9	WEAR PLATE	1		(KIT AH131176)
10	H116213	DOWEL PIN	4		
11	H80821	O-RING	2		(KIT AH131176)
12	AH134554	GEAR	1		
13	GEAR	1		(SUB AH134555)
14	HOUSING	1		(SUB AH134555)
15	PLATE	1		(SUB AH134555)
16	AH134555	PUMP	1		REMANUFACTURED (CESSNA NO. R25305 - RAL)
..	AH131176	SEAL KIT	1		

2H6

FC: 5514

SEPARATOR

LOWER TROUGH SUPPORT AND TAILINGS DRIVE BRACKET
HP3124 -UN-01JAN94

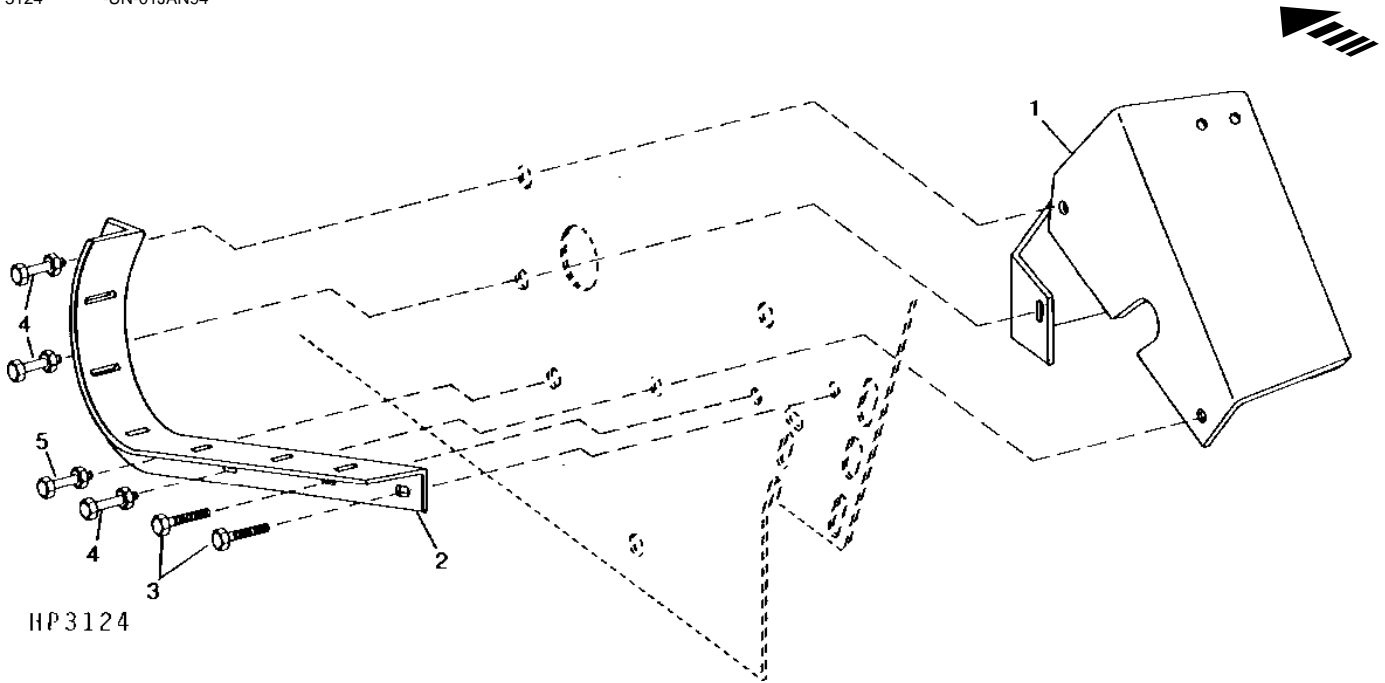

KEY	PART NO.	PART NAME	QTY	SERIAL NO.	REMARKS
1	AH131080	BRACKET	1		
2	H134317	SUPPORT	1		
3	19M7866	SCREW	2	M8 X 20	
4	19M7867	SCREW	3	M8 X 25	
	14M7298	FLANGE NUT	3	M8	
5	19M7866	SCREW	1	M8 X 20	
	14M7298	FLANGE NUT	1	M8	

2H14

FC: 5516

SEPARATOR

UPPER TAILINGS AUGER, DRIVE AND SHIELD - CONTINUED

KEY	PART NO.	PART NAME	QTY	SERIAL NO. OR YEAR	REMARKS
1	H138435	SET SCREW	2		
2	14M7274	NUT	2		M10
3	22M7079	SET SCREW	1	-MAR92	M6 X 6, (SUB 22M7111)
	22M7111	SET SCREW	1		M6 X 6
4	AZ10044	ECCENTRIC LOCKING COLLAR	1		
5	H103264	PRESSED FLANGED HOUSING	2		
6	JD39102	BALL BEARING	1		
7	H134055	END PLATE	1	-SEPT92	(SUB H148633)
	H148633	END PLATE	1		
8	SHAFT KEY	1		8 X 7 X 40 MM (IN AH141142 KEY STOCK KIT) (CUT FROM H150269)
9	AH125895	AUGER	1		
10	03M7184	BOLT	AR		M8 X 20
	14M7298	FLANGE NUT	AR		M8
11	19M8317	SCREW	AR		M8 X 40
12	H134962	BEARING	1		WOOD, BEARING
13	H134963	RETAINER	1		
14	28H3367	BUSHING	1		0.364" X 0.540" X 4-1/8", (SUB H140467)
	H140467	BUSHING	1		9.246 X 13.716 X 104.775 MM (0.364" X 0.540" X 4-1/8")
15	AH130982	SHIELD	1	-640400	
	AH135207	SHIELD	1	640401-	
16	19M8262	CAP SCREW	1		M8 X 130
	14M7298	FLANGE NUT	1		M8
17	19M7862	SCREW	1		M6 X 20
	14M7303	FLANGE NUT	1		M6
18	ROLLER CHAIN	1		ROLLER, TYPE 50, 16MM (5/8") PITCH, 124 LINKS, (ASSEMBLE FROM AH18484 OR AP22459 AND (1) P20351)
19	AH121046	CHAIN SPROCKET	1		22 TOOTH

2H25

FC: 5512

GRAIN TANK AND UNLOADING AUGER

CLEAN GRAIN LOWER ELEVATOR BOOT AND DOOR - CONTINUED

KEY	PART NO.	PART NAME	QTY	SERIAL NO.	REMARKS
1	H101297	LEVER	1		
2	11M7081	COTTER PIN	1		2.500 X 20 MM
	11H211	COTTER PIN	1	-OCT92	1/8" X 3/4", (SUB 11M1383) (STAINLESS STEEL)
	11M1383	COTTER PIN	1		3.200 X 20 MM (0.126" X 0.787")
3	RV810A	PIN	14		
4	03M7251	BOLT	14		M6 X 12
	14M7303	FLANGE NUT	14		M6
5	AH136484	BOOT	1		(SUB AH136485)
	AH136485	BOOT	1		(STAINLESS STEEL)
6	19M7865	SCREW	8		(SUB AH129357) (STANDARD)
7	H128877	U-BOLT	1		
8	14M7396	LOCK NUT	2		M8
9	AH129357	DOOR	1		(STAINLESS STEEL)
	AH127396	DOOR	1		(PERFORATED)
10	H75985	DOWEL PIN	1		(6.88 IN.) NO LONGER AVAILABLE (MAKE FROM H76083)

2110

FC: 5513

GRAIN TANK AND UNLOADING AUGER

CLEAN GRAIN LOADING AUGER - CONTINUED

KEY	PART NO.	PART NAME	QTY	SERIAL NO.	REMARKS
1	19M7818	SCREW	1		M12 X 80
2	24M7180	WASHER	1		13 X 37 X 3 MM
3	14M7298	FLANGE NUT	2		M8
4	N15764	PRESSED FLANGED HOUSING	2		
5	JD9219	BALL BEARING	1		
6	H137916	SHIM	2		
7	03M7185	BOLT	2		M8 X 25
8	AH136091	AUGER	1		
9	SHAFT KEY	1		6 X 32 MM (IN AH141142 KEY STOCK KIT) (CUT FROM H150268)
10	H136186	AUGER	1		
11	14M7291	FLANGE NUT	1		M16
12	H137919	BUSHING	1		

2120

FC: 5551

GRAIN TANK AND UNLOADING AUGER

GRAIN TANK TOP - CONTINUED

KEY	PART NO.	PART NAME	QTY	SERIAL NO. OR YEAR	REMARKS
1	H133584	BRACKET	1		
2	H127638	PANEL	1		
3	19M7865	SCREW	6		M8 X 16
4	AH136558	TANK	1	-640400	(SUB AH134765)
	AH134765	TANK	1		
5	03M7183	BOLT	6		M8 X 16
	14M7298	FLANGE NUT	2		M8
6	AH125644	LATCH	1		
7	H64584	RIVET	2		
8	AH122507	DOOR	1		
9	H132024	HINGE	2		
10	H120499	NUT	2		
11	AH80335	WEATHERSTRIP	AR		
12	B27370	WASHER	4		8.331 X 19.050 X 0.914 MM (21/64" X 3/4" X 0.036")
13	19M7866	SCREW	2		M8 X 20
14	AH126619	REINFORCEMENT	1		
15	H131675	WINDOWPANE	1		
16	14M7019	WING NUT	2		M6
17	H131674	LATCH	2		
18	19M7862	SCREW	4		M6 X 20
19	R50642	WASHER	4		
20	H131673	GASKET	2		
21	14M7303	FLANGE NUT	8		M6
22	14M7396	LOCK NUT	2		M8
23	H132542	ANGLE	2		
24	14M7298	FLANGE NUT	4		M8
25	H131531	NUT	4		(SUB M84309)
	M84309	NUT	4		
26	19M7866	SCREW	4		M8 X 20 M8
27	AH128554	LADDER	1		
28	19M7866	SCREW	5		M8 X 20
	14M7298	FLANGE NUT	5		M8
29	19M7865	SCREW	13		M8 X 16
	14M7298	FLANGE NUT	13		M8
30	37M7058	SCREW	21		M8 X 20
31	H130262	PANEL	1		ROLLING THREAD
32	H132666	PLATE	2		
33	19M7774	SCREW	4		M6 X 12
34	H121391	KNOB	1		

2J6

FC: 5552

GRAIN TANK AND UNLOADING AUGER

HORIZONTAL UNLOADING AUGER SWIVEL - CONTINUED

KEY	PART NO.	PART NAME	QTY	SERIAL NO. OR YEAR	REMARKS
1	AH131240	HOUSING	1	(SUB AH131241)	
	AH131241	HOUSING	1	(SUB AH145051)	
	AH145051	HOUSING	1		
2	JD7806	LUBRICATION FITTING	1	90 DEGREE	
3	H96228	SCREW	1		
4	AH123912	SUPPORT	1		
5	12H304	LOCK WASHER	4	3/8"	
6	19H2676	CAP SCREW	4	3/8" X 1"	
7	24H1305	WASHER	1	13/32" X 13/16" X 0.065"	
8	19H1732	CAP SCREW	1	3/8" X 1-1/4"	
	E55662	FLANGE NUT	1	3/8"	
9	H116351	STRAP	1		
10	24H1224	WASHER	4	11/32" X 1" X 1/16", (SUB 24M7207)	
11	14H785	NUT	4	5/16"	
12	H96652	DOOR	1		
13	WEATHERSTRIP	AR	(CUT FROM H81330)	
14	H133178	CLAMP	1		
15	AH136153	STRAP	1		
16	19M7786	SCREW	4	M10 X 30	
	24H1311	WASHER	4	13/32" X 1-1/4" X 0.220"	
	14M7296	FLANGE NUT	4	M10	
17	03M7190	BOLT	2	M10 X 20	
	14M7296	FLANGE NUT	2	M10	
18	11M7038	COTTER PIN	2	6.300 X 40 MM	
19	H138930	PIN	1		
20	H137225	END	1		
21	H137227	RING	1		
22	03M7198	BOLT	12	M12 X 30	
	14M7299	FLANGE NUT	12	M12	
23	H131356	SECTOR	3		
24	24H1308	WASHER	4	13/32" X 1" X 0.134"	
25	12H294	LOCK WASHER	1	5/8"	
26	19M7784	SCREW	12	M10 X 20	

2J15

FC: 5552

GRAIN TANK AND UNLOADING AUGER

HORIZONTAL UNLOADING AUGER - CONTINUED (14 AND 17 FT. (1) PIECE AUGERS)

KEY	PART NO.	PART NAME	QTY	SERIAL NO.	REMARKS
1	N72989	BUSHING	1		
2	AH122717	GUDGEON	1		(14 FT. ONLY) FOR AUGER REPAIR ONLY
	H127921	SPLINED COUPLING	1		W/O WASHER (17 FT. ONLY) FOR AUGER REPAIR ONLY
3	24H1300	WASHER	AR		25/64" X 2" X 0.220"
	24H1311	WASHER	AR		13/32" X 1-1/4" X 0.220"
4	H119566	STRIP	AR		100 MM (4") LONG
	H119567	STRIP	AR		120 MM (5") LONG
	H119568	STRIP	AR		150 MM (6") LONG
5	03H1495	BOLT	AR		3/8" X 1-1/2"
	03H1557	BOLT	AR		3/8" X 1-1/4"
	K40003	LOCK NUT	AR		
6	AH123436	AUGER	1	-JUL92	(14 FT.) INCLUDES AH122717 AND H127921
	AH132032	AUGER	1		(14 FT.) INCLUDES AH122717 AND H127921
	AH123437	AUGER	1	-640400	(17 FT.) INCLUDES AH122717 AND H127921
	AH132033	AUGER	1	640400-APR93	(17 FT.) INCLUDES AH122717 AND H127921
	AH143729	AUGER	1		
7	AH111354	SEAL	1	-640400	
8	H113717	CLIP	3	-640400	
9	H114709	CLIP	6	-640400	
10	21H1029	SCREW	3		5/16" X 3/4", (SUB 21H1304)
	12H303	LOCK WASHER	3	-640400	5/16"
	14H785	NUT	3	-640400	5/16"
11	03M7184	BOLT	3		M8 X 20
	14M7298	FLANGE NUT	3		M8
12	22H897	SET SCREW	1		1/4" X 1/4"
13	JD8554	ECCENTRIC LOCKING COLLAR	1		
14	H103264	PRESSED FLANGED HOUSING	2		
15	JD8665	BALL BEARING	1		
16	H96645	CAP	1		
17	19M7866	SCREW	5		M8 X 20
	14M7298	FLANGE NUT	5		M8
18	J18468	SPRING	2	640401-	
19	AH132230	DOOR	1	640401-	(INCLUDES Z24604)
20	19M7868	SCREW	1		M8 X 30
21	14M7298	FLANGE NUT	2		M8

FC: 0000

GRAIN TANK AND UNLOADING AUGER

MEMORANDA

2K6

FC: 5281

DIAL-A-MATIC HEADER HEIGHT CONTROL

ELECTRICAL HARNESS - CONTINUED (DIAL-A-MATIC HEADER HEIGHT CONTROL)

KEY	PART NO.	PART NAME	QTY	SERIAL NO.	REMARKS
1	37M7083	SCREW	1		M8 X 12
2	AH89557	CLIP	2		
3	AH200280	WIRING HARNESS	1		LH MAIN
4	AH89557	CLIP	3		
5	03M7189	BOLT	3		M8 X 45
	14M7298	FLANGE NUT	3		M8
6	H137939	LABEL	1		"IMPORTANT", (HARNESS AND HOSE STORAGE)
7	03M7183	BOLT	1		M8 X 16
	14M7298	FLANGE NUT	1		M8
8	H134417	BRACKET	1		
9	H130520	CAP	1		(SUB H130520)
10	AH128924	WIRING HARNESS	1		PIGTAIL TO CONNECT FEEDER HOUSE AND 200, 50,OR 50A SERIES ETC. ALSO REQUIRES AH89557 CLAMP, 19M7866 SCREW AND 14M7298 NUT
11	H132800	HOSE	1		SLEAVE FOR PROTECTION
12	19M7866	SCREW	1		
13	14M7298	FLANGE NUT	1		

2K14

FC: 0000

DECALS, BELTS AND CHAINS

LEFT-HAND DECALS - CONTINUED

KEY	PART NO.	PART NAME	QTY	SERIAL NO.	REMARKS
12	H110923	LABEL	1		HYDRAULIC RESERVOIR LABEL ON R.H. SIDE OF HYDRAULIC RESERVOIR
13	H137356	LABEL	1		"STYLING PANEL" CENTERED ON L.H. REAR PANEL
14	H120924	LABEL	1		"STYLING PANEL" CENTERED ON L.H. SIDE OF REAR HOOD
15	H138989	LABEL	1	-SEPT94	(SUB H149096) "PROJECTILE WARNING" ON R.H. SIDE OF REAR HOOD
	H149096	LABEL	1		"PROJECTILE WARNING" ON R.H. OF REAR HOOD
16	H139431	LABEL	1		(SUB H145857) "CHOPPER POSITION LABEL" OF CHOPPER HOUSING
17	H133643	LABEL	1	-SEPT94	(SUB H149067) "WARNING" ON MID SIL
	H149067	LABEL	1		"WARNING" ACCUMULATOR
18	H138423	LABEL	1		(SUB H149092) "CAUTION" ON ACCUMULATOR
19	H139948	LABEL	1		(SUB H149099) "WARNING" ON FRONT OF TAILINGS ELEVATOR
	H149099	DECAL	1		
20	JD5255	DECAL	1	-AUG94	(SUB E82510) "CAUTION" ON SIDE SHIELD
21	H135405	LABEL	1		"FEEDER HOUSE CHAIN LABEL" ON L.H. SIDE OF FEEDER HOUSE
22	H81662	DECAL	1		(SUB H149107) "WARNING" HITCH TUBE

1L15

9501 PULL-TYPE COMBINE

NUMERICAL INDEX - CONTINUED

PART NO.	GRID	KEY	PAGE	PART NO.	GRID	KEY	PAGE	PART NO.	GRID	KEY	PAGE
AH93918	1C21	19	50 - 5	AZ10044	2H14	4	120 - 169	E50096	2A25	10	120 - 9
AH93991	1C25	29	50 - 9	AZ10044	2H23	3	130 - 3	E50613	1C21	8	50 - 5
AH93991	1C25	34	50 - 9	AZ10045	2G24	3	120 - 153	E50613	1C23	18	50 - 7
AH93991	1C25	36	50 - 9	AZ10045	2H11	13	120 - 165	E52205	1C21	1	50 - 5
AH93991	1C25	37	50 - 9	AZ10045	2H23	9	130 - 3	E53699	1H8	12	110 - 3
AH93991	1C25	..	50 - 9	AZ10045	2I6	2	130 - 11	E55662	2J6	8	130 - 35
AH94450	1D2	5	50 - 11	AZ19427	2C22	5	120 - 55	E58144	2E4	22	120 - 85
AH94450	1H10	11	110 - 5	AZ20216	2E18	15	120 - 99	E59406	2E18	10	120 - 99
AH94450	2E4	14	120 - 85	AZ47075	1E23	24	70 - 39	E61791	2G20	1	120 - 149
AH94450	2E16	10	120 - 97	AZ47075	1F5	10	70 - 47	E62089	1E15	6	70 - 31
AH94450	2I14	5	130 - 19	A15146	1H12	8	110 - 7	E62089	1E18	2	70 - 34
AH94480	1D9	9	50 - 18	A15146	2I14	18	130 - 19	E62089	1E19	6	70 - 35
AH94480	1D9	..	50 - 18	A15147	2C24	2C	120 - 57	E62089	1E21	2	70 - 37
AH94661	2J11	3	130 - 40	A15898	1D15	1	70 - 3	E62089	1E23	6	70 - 39
AH94853	2D6	24	120 - 63	A15898	2G18	12	120 - 147	E62089	1E25	2	70 - 41
AH94854	2D18	15	120 - 75	A25695	1H10	16	110 - 5	E62089	1F1	6	70 - 42
AH96244	2D4	15	120 - 61	A31867	1H10	10	110 - 5	E62089	1F3	2	70 - 44
AH96249	1A25	6	40 - 11	A31867	2B8	19	120 - 17	E62092	1E23	17	70 - 39
AH96359	1E15	..	70 - 31	A31870	1I8	3	110 - 27	E62092	1F1	17	70 - 42
AH96359	1E17	4	70 - 33	A31870	2G24	23	120 - 153	E62092	1E23	15	70 - 39
AH96359	1E19	..	70 - 35	A3581R	2I14	18	130 - 19	E62094	1E23	14	70 - 39
AH96359	1E20	4	70 - 36	A4655R	1E13	2	70 - 28	E62094	1F1	14	70 - 42
AH96359	1E23	..	70 - 39	A4655R	1E15	1	70 - 31	E62892	1F5	6	70 - 47
AH96359	1E24	4	70 - 40	A4655R	1E19	1	70 - 35	E62917	1E19	22	70 - 35
AH96359	1F1	..	70 - 42	A4655R	1E23	1	70 - 39	E62917	1F5	11	70 - 47
AH96359	1F2	4	70 - 43	A4655R	1F1	1	70 - 42	E62942	1E13	3	70 - 28
AH96585	2J2	5	130 - 31	A4655R	1F5	21	70 - 47	E62942	1E15	2	70 - 31
AH97031	2D6	7	120 - 63	BP12214	1H4	15	80 - 35	E62942	1E19	2	70 - 35
AH97031	2D22	11	120 - 79	BP13616	2E18	13	120 - 99	E62942	1E23	2	70 - 39
AH97340	1H10	2	110 - 5	BP13620	1H8	22	110 - 3	E62942	1F1	2	70 - 42
AH97642	1H22	17	110 - 17	BP13620	2E2	1	120 - 83	E62942	1F5	19	70 - 47
AH98118	2J11	1	130 - 40	B10604	2D22	3	120 - 79	E64256	2F4	13	120 - 109
AH98176	2H12	7	120 - 166	B11182	1C19	6	50 - 3	E64256	2J22	14	130 - 53
AH98901	1B21	14	40 - 33	B27370	2I20	12	130 - 25	E66618	1E15	24	70 - 31
AL14674	2B22	22	120 - 31	B27370	2I24	2	130 - 29	E66619	1E15	19	70 - 31
AL14674	2E4	50	120 - 85	B27835	2F10	35B	120 - 115	E66620	1E15	18	70 - 31
AL2976T	1C14	20	40 - 51	B28970	2F10	29	120 - 115	E70736	2B6	8	120 - 15
AM103480	2F24	4	120 - 129	B28970	2F14	7	120 - 119	E73557	1E13	1B	70 - 28
AM1717T	2D4	40	120 - 61	B2984R	2E18	14	120 - 99	E73558	1E13	1A	70 - 28
AN113330	1H8	29	110 - 3	B3118R	1H8	13	110 - 3	E74026	1D8	12	50 - 17
AN12151	1H8	19	110 - 3	B3118R	2D18	8	120 - 75	E74026	2K13	1	170 - 8
AN122518	1E15	21	70 - 31	B32630	1C4	2	40 - 41	E76372	2F10	37A	120 - 115
AN15237	2E20	10	120 - 101	C10232	1I2	10	110 - 21	E82510	1G15	6	80 - 21
AN15237	2I14	8	130 - 19	C10232	1I2	35	110 - 21	E82510	2K14	20	170 - 9
AN31004	1C25	42	50 - 9	C10232	2H5	10	120 - 158	E82514	1D8	12	50 - 17
AN31004	1H8	37	110 - 3	C10232	2I2	10	130 - 7	E82514	2K13	1	170 - 8
AP23601	2F10	39	120 - 115	C10233	2H5	10	120 - 158	E83620	1E15	18	70 - 31
AR21837	2E2	10	120 - 83	C10233	2I2	10	130 - 7	GN11175	1D8	11	50 - 17
AR28339	1G25	7	80 - 31	C10263	2H5	10	120 - 158	GN11175	2K13	2	170 - 8
AR42591	1B21	12	40 - 33	C10263	2I2	10	130 - 7	HZ5621H	1H2	7	80 - 33
AR60499	2D4	17	120 - 61	C12152	1A17	18	40 - 3	H100334	1C21	18	50 - 5
AR60499	2D6	12	120 - 63	C16054	1E7	16	70 - 21	H100796	2E8	22	120 - 89
AR62407	1B22	1	40 - 34	C565R	1D10	12	50 - 19	H101161	1A17	15	40 - 3
AR65005	1C15	1	40 - 52	E10018	2B18	19	120 - 27	H101297	2H4	15	120 - 157
AR65006	1C15	2	40 - 52	E10018	2E4	42	120 - 85	H101297	2H25	1	130 - 5
AR82993	1C25	22	50 - 9	E10018	2G24	4	120 - 153	H101317	1A17	16	40 - 3
AR84006	1C14	40	40 - 51	E10018	2H5	5	120 - 158	H101677	1I8	8	110 - 27
AR90369	2E2	8	120 - 83	E10018	2H11	14	120 - 165	H102497	1I8	7	110 - 27
AR90583	1C19	30	50 - 3	E10018	2H23	10	130 - 3	H102533	2B18	21	120 - 27
AR90861	2D24	19	120 - 81	E10018	2I6	3	130 - 11	H102533	2D6	38	120 - 63
AR91793	1A25	3	40 - 11	E12305	2D10	22	120 - 67	H102533	2E4	43	120 - 85
AR91793	1C12	42	40 - 49	E12379	2B12	22	120 - 21	H102844	1G2	7	80 - 7
AR94522	1D15	2	70 - 3	E12379	2H16	4	120 - 171	H102909	2J19	7	130 - 49
AR94522	1D19	4	70 - 7	E12379	2H18	6	120 - 173	H103264	2B16	18	120 - 25
AR94522	2G18	13	120 - 147	E12379	2K2	1	130 - 59	H103264	2G2	15	120 - 131
AT25226	1D10	6	50 - 19	E18993	2D16	6	120 - 73	H103264	2H14	5	120 - 169
AZ10044	2B22	5	120 - 31	E47782	2B8	20	120 - 17	H103264	2H23	4	130 - 3

CLICK HERE TO **DOWNLOAD** THE COMPLETE MANUAL

- Thank you very much for reading the preview of the manual.
- You can download the complete manual from: www.heydownloads.com by clicking the link below



- Please note: If there is no response to CLICKING the link, please download this PDF first and then click on it.

CLICK HERE TO **DOWNLOAD** THE COMPLETE MANUAL