

# Parts Catalogue

## DFP6 Forward Plate

Engine : Honda GX 120 - CARB Phase III



No. DL00826137 | 2022-01-04

© 2022 Dynapac GmbH

*Your Partner  
on the Road Ahead*

CLICK HERE TO **DOWNLOAD** THE COMPLETE MANUAL

- Thank you very much for reading the preview of the manual.
- You can download the complete manual from: [www.heydownloads.com](http://www.heydownloads.com) by clicking the link below



- Please note: If there is no response to CLICKING the link, please download this PDF first and then click on it.

CLICK HERE TO **DOWNLOAD** THE COMPLETE MANUAL

# Forward Plate DFP6

Item	Part No.	Qty	Name	SN INFO
KIT	4812216977	1	Repair kit, transmission	
1	DL05650122	1	Centrifugal clutch	
2	DL92410581	1	V-belt	
3	DL09181604	1	Fitting key	
4	DL23010140	1	V-belt pulley	
5	DL23010132	1	Washer	
6	DL07230819	1	Socket-head cap screw	

# Forward Plate DFP6

Item	Part No.	Qty	Name	SN INFO
KIT	4812073594	1	Refurbishing kit - decals	
1	DL00833977	1	Decal,maintenance instr.	
2	DL00833000	1	Decal,operation	
3	DL00833833	1	Decal,indication	
4	DL00833226	1	Decal,indication	
5	DL05050358	1	Decal,indication	
6	DL05050359	1	Decal,indication	
7	DL00832651	1	Decal,indication	
8	DL00833653	1	Decal,indication	
9	DL92410409	1	Type designation	
10	DL92410221	1	Decal	
11	DL00833968	1	Warning sign	

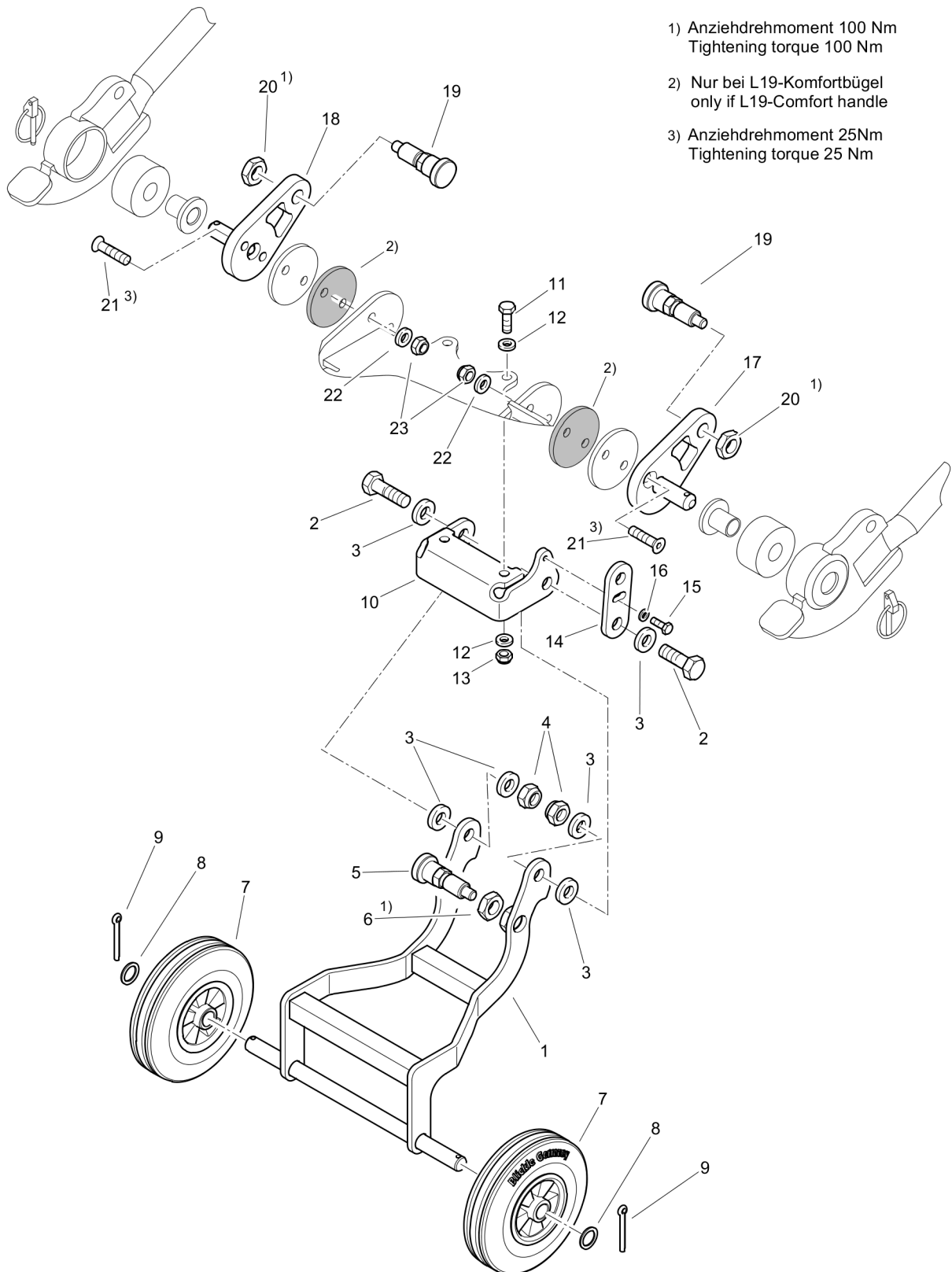

Refer to Parts Online for the most up to date information. The printed information might be outdated.

Thu Dec 30 11:51:27 UTC 2021

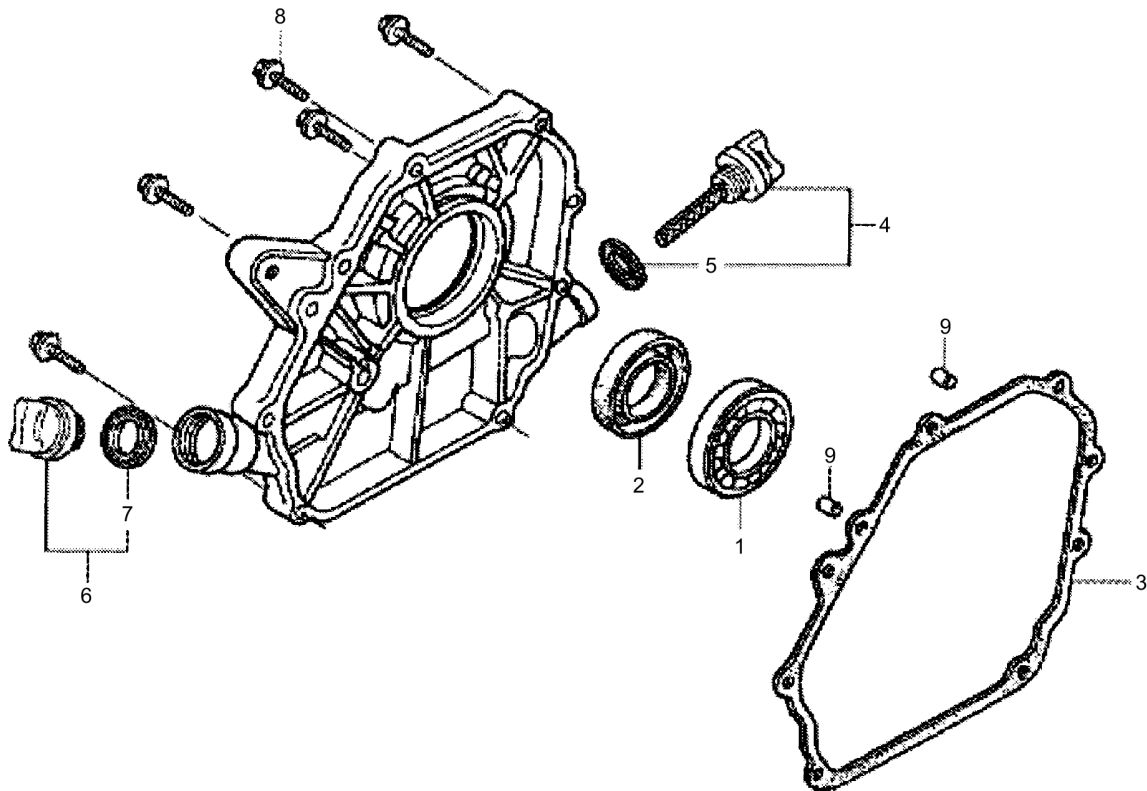

## 11.02

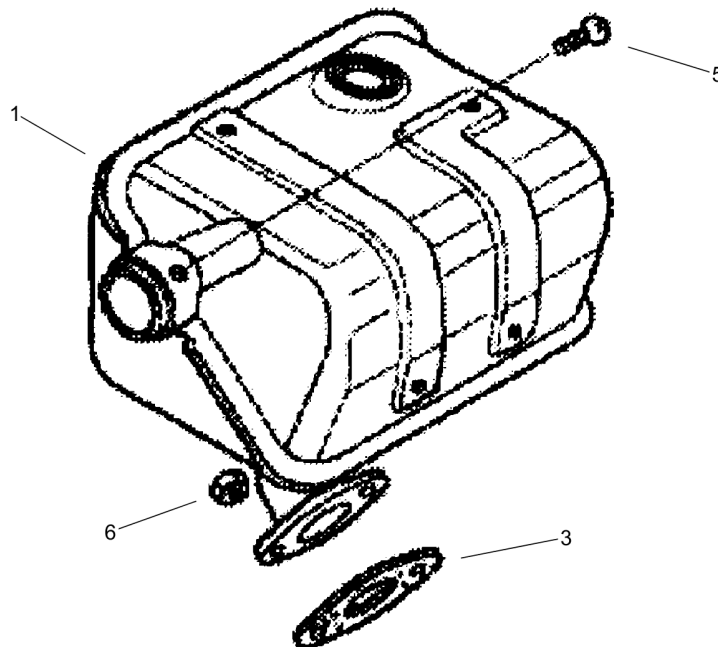
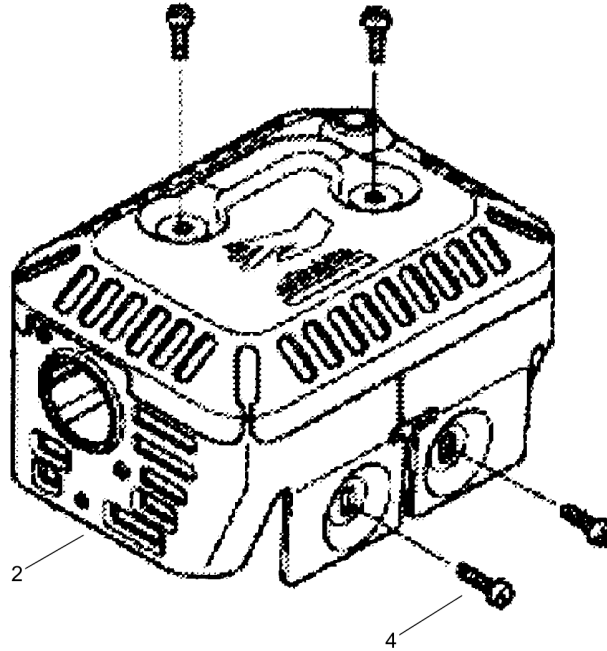

## 11.26

Refer to Parts Online for the most up to date information. The printed information might be outdated.

Thu Dec 30 11:51:32 UTC 2021

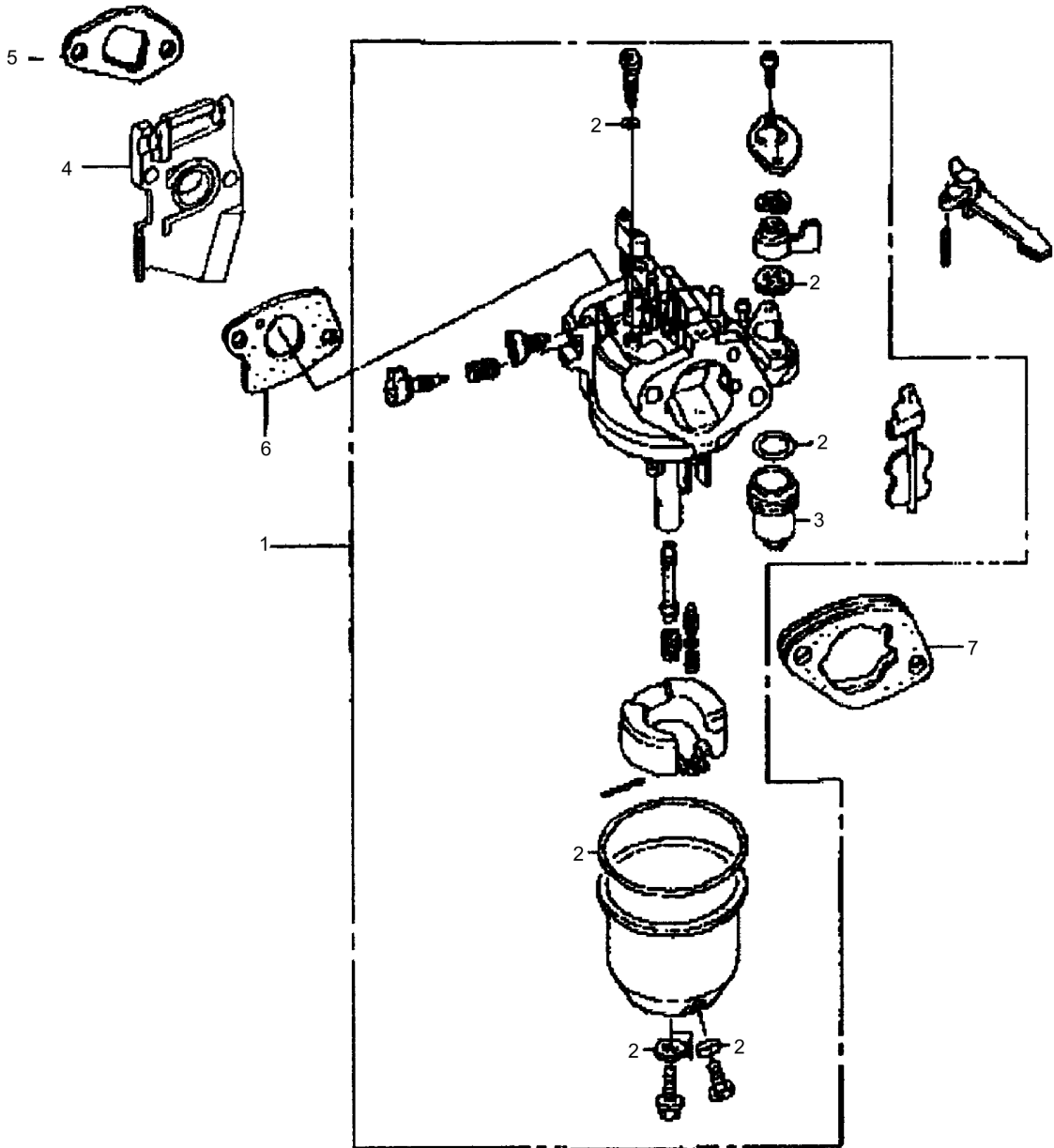

# 11.53

Refer to Parts Online for the most up to date information. The printed information might be outdated.

Thu Dec 30 11:51:34 UTC 2021

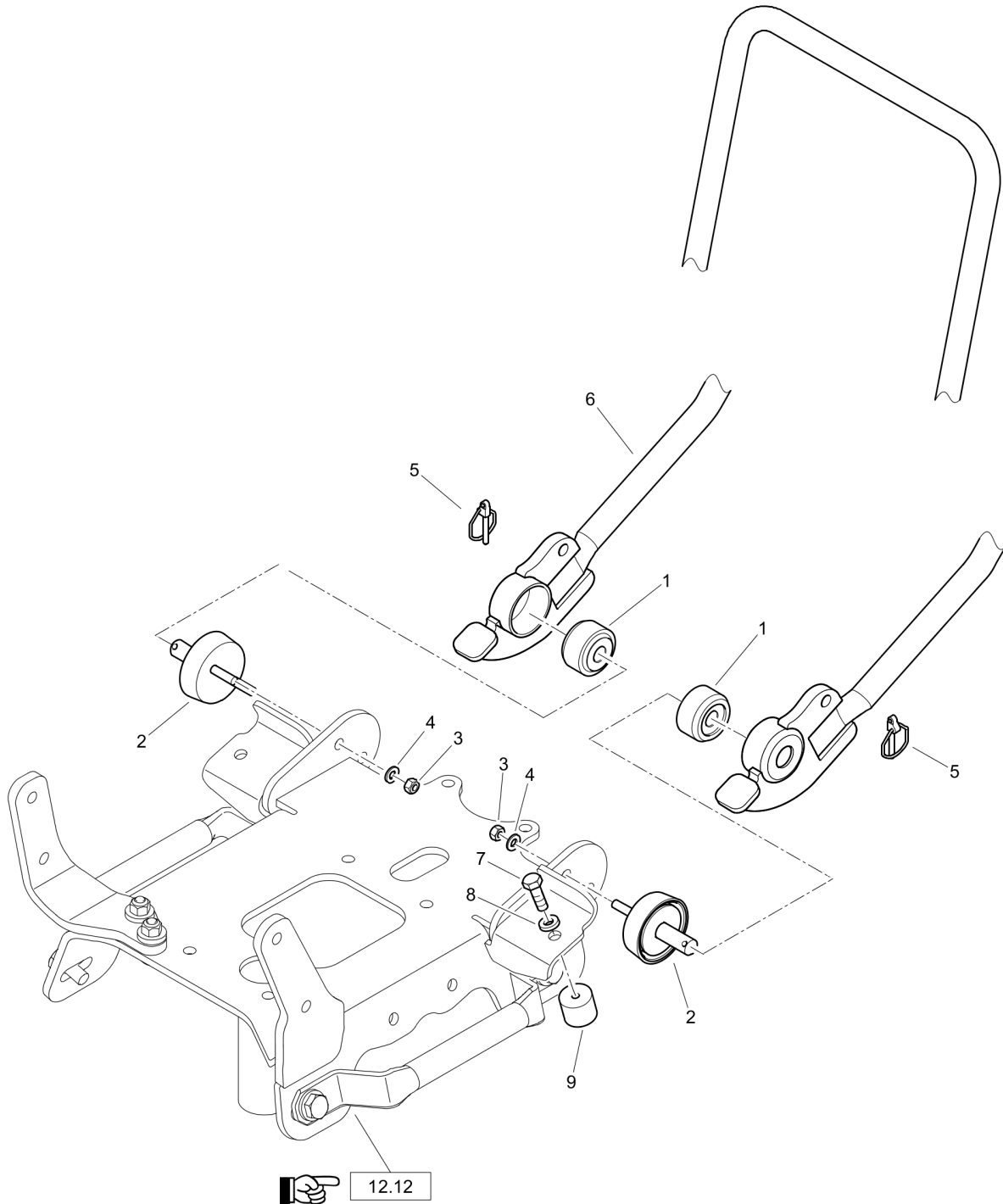

## 52.16

Refer to Parts Online for the most up to date information. The printed information might be outdated.

Thu Dec 30 11:51:36 UTC 2021

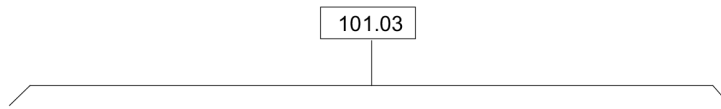

**Special Equipment** DL23003471\_00 Water tank, assembled

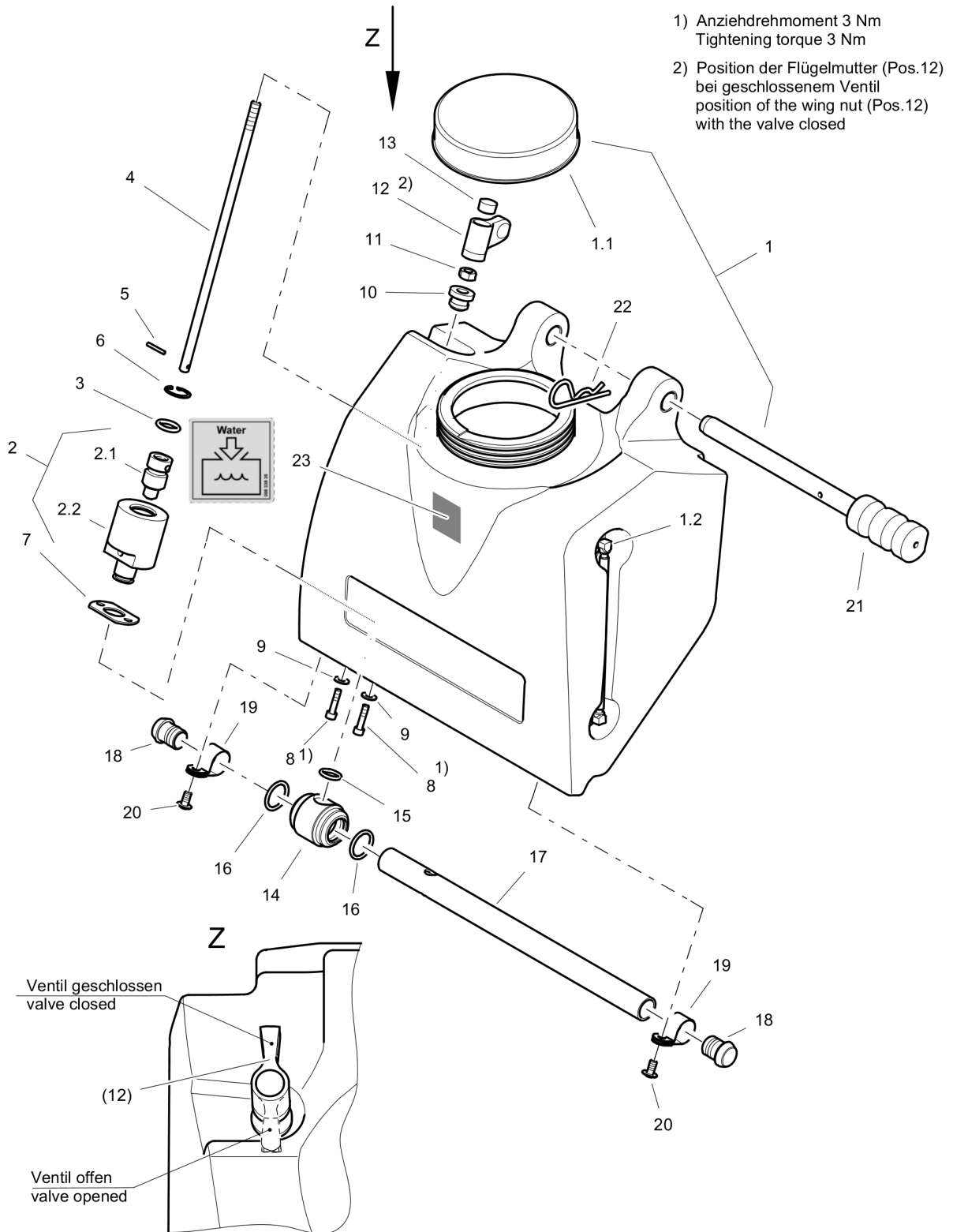

# 152.31

Refer to Parts Online for the most up to date information. The printed information might be outdated.

Thu Dec 30 11:51:41 UTC 2021

CLICK HERE TO **DOWNLOAD** THE COMPLETE MANUAL

- Thank you very much for reading the preview of the manual.
- You can download the complete manual from: [www.heydownloads.com](http://www.heydownloads.com) by clicking the link below



- Please note: If there is no response to CLICKING the link, please download this PDF first and then click on it.

CLICK HERE TO **DOWNLOAD** THE COMPLETE MANUAL