

6090 ->14500

HU - ATTACHMENTS AND ACCESSORIES

GENERAL

L.U.M. 6090.....	HU.00.3 (1)
ORIGINAL PARTS CATALOGUE 6090.....	HU.00.9 (1)
ORIGINAL PARTS CATALOGUE HMW 1124-1133.....	HU.00.15 (1)
ORIGINAL PARTS CATALOGUE RAPS.....	HU.00.21 (1)

CHAFF SPREADER

CHAFF SPREADER.....	HU.01.1 (1)
CHAFF SPREADER.....	0.016.8148.4.A
LOAD BEARING FRAME.....	0.016.8148.4.B
COOLING FAN.....	0.016.8148.4.C
TENSION ROLLER.....	0.016.8148.4.D
TENSION ROLLER.....	0.016.8148.4.E

STRAW CHOPPER

STRAW CHOPPER KPAB, STD.....	HU.02.2 (1)
STRAW CHOPPER KPAB, STD.....	HU.02.3 (1)
STRAW CHOPPER KPAB, STD.....	HU.02.7 (1)
PROTECTIVE COVER.....	HU.02.10 (1)
GUARD PLATE.....	HU.02.11 (1)
GUARD PLATE.....	HU.02.15 (1)
STRAW CHOPPER GEARBOX.....	HU.02.17 (1)
STRAW CHOPPER.....	0.016.8145.4.A
SHAFT WITH BLADES - MM. 4.00.....	0.016.8145.4.B
COUNTER-BLADE.....	0.016.8145.4.C
SIDE COVERS.....	0.016.8145.4.D
TENSION ROLLER.....	0.016.8145.4.E
COVER PLATE SX / LH / LI.....	0.016.8145.4.F
COVER PLATE DX / RH / RE.....	0.016.8145.4.G
BELT GUIDE.....	0.016.8145.4.H
ENGAGEMENT.....	0.016.8145.4.I
CLUTCH.....	0.016.8145.4.J
TENSION ROLLER.....	0.016.8145.4.K
STRAW DEFLECTORS.....	0.016.8145.4.L
STRAW DEFLECTORS W.....	0.016.8145.4.M
SHAFT WITH BLADES - MM 5.0.....	0.016.8145.4.N
SPECIAL EQUIPMENT FOR MAIZE.....	0.016.8712.4.A

REAR HITCHES

DRAWBAR COUPLING (CUNA C).....	HU.03.0 (1)
DRAWBAR COUPLING.....	HU.03.1 (1)
DRAWBAR COUPLING.....	HU.03.2 (1)
REAR TOWING HITCH.....	0.016.8447.3.A
DRAWBAR COUPLING.....	06500047.A

CLICK HERE TO **DOWNLOAD** THE COMPLETE MANUAL

- Thank you very much for reading the preview of the manual.
- You can download the complete manual from: www.heydownloads.com by clicking the link below



- Please note: If there is no response to CLICKING the link, please download this PDF first and then click on it.

CLICK HERE TO **DOWNLOAD** THE COMPLETE MANUAL

COOLING FAN

Fig.	Code	QTY	Name
3	0.900.1182.4	1	box dx/rh/re
4	0.900.1182.5	1	box sx/lh/li
15	0.900.1183.5	1	rotor blade dx/rh/re
16	0.900.1183.6	1	rotor blade sx/lh/li
27	16055969	2	washer
33	01108524	10	screw m 8 p.1.25 x 20
34	16023425	10	washer 8.4
35	01104944	10	nut m 8, d985
43	0.900.1184.5	12	kit
44	01112341	2	screw m 8 x 30, d933
45	01102799	2	washer 8, d128

0_016_8148_4_C

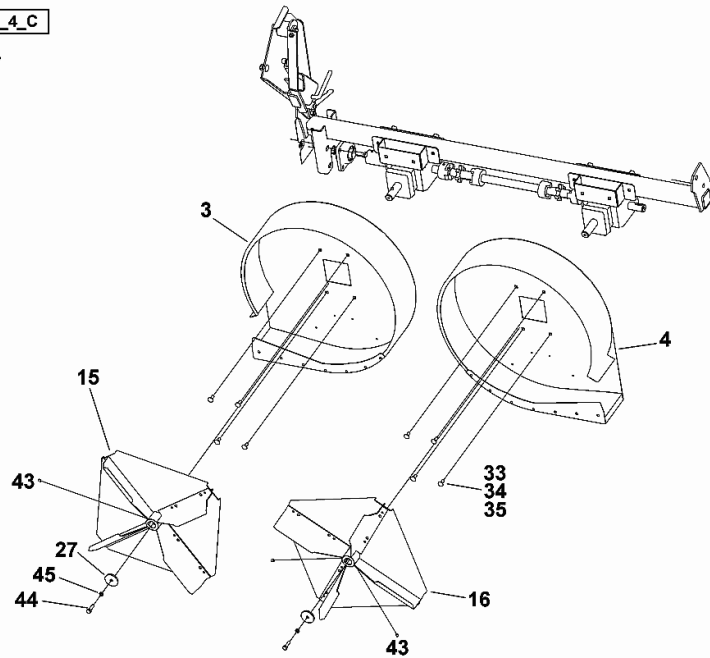

STRAW CHOPPER

Fig.	Code	QTY	Name
1	0.900.1191.0	1	chassis
2	16031588	1	rotor kpl.
3	0.900.1191.1	1	chopper knife kpl.
4	16023175	2	bearing 45 kpl.
5	06207555	2	screw m 12 x 45
6	0.900.1191.2	6	screw m 12 x 35
7	16023422	12	nut m12 loc-king
8	16039163	2	nut m 12
9	01120695	2	lubricator 1/8" d71412
10	01138811	2	screw m 12 x 30
11	16023427	4	washer 12,5 x 35
12	01102801	2	washer 12
13	16039120	2	guard
14	01108524	14	screw m 8 p.1.25 x 20
15	01104944	16	nut m 8, d985
16	06214246	11	washer 9.0 x 18 x 2.0
17	16039126	1	guard
18	16039129	1	support
19	16039130	1	rubber
20	16055841	1	support
21	16031426	1	pulley Ø 222
22	0.900.1185.9	2	kit
23	01118268	1	dowel 10 x 8.0 x 63, d6887
24	16023191	1	frame
25	01112407	5	screw m 10 x 20, d933
26	16023426	5	washer 10,5 x 26
27	06209768	5	nut m 10, d985
28	16039122	1	console
29	16039123	1	sump
30	16023425	3	washer 8.4
31	16023108	2	screw m 8, 4610
32	16052833	2	bushing
33	01112560	2	screw m 12 x 50

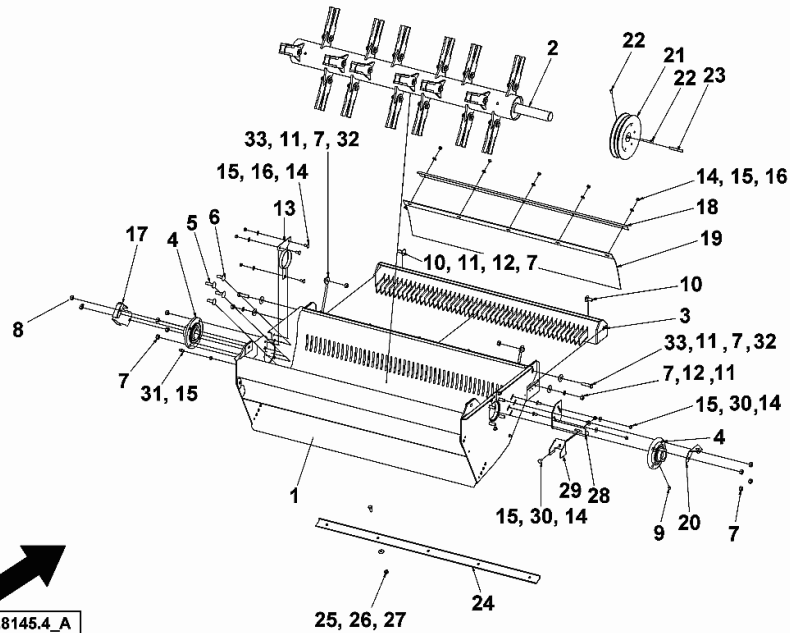

0.016.8145.4_A

CLUTCH

Fig.	Code	QTY	Name
1	16055860	1	shaft
2	16039151	1	pulley Ø 260
3	16055861	1	pulley Ø 206
4	0.900.0912.0	1	pulley
5	01118268	2	dowel 10 x 8.0 x 63, d6887
6	01120695	2	lubricator 1/8" d71412
7	16023193	2	bearing
8	0.900.1185.9	4	kit
9	01112456	6	screw m 10 x 50
10	06209768	6	nut m 10, d985
11	01107165	12	washer 10.5

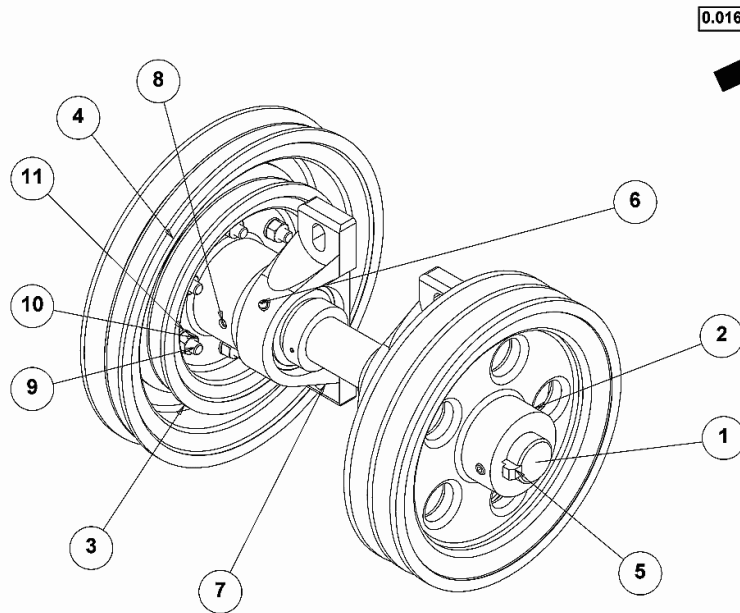

DRAWBAR COUPLING

Fig.	Code	QTY	Name
------	------	-----	------

Notes:

[6090 ->14500]

1	16044682	1	tow hook ☞ 16044682
2	16046248	1	power control
3	16063117	4	screw m 14x70
4	01115040	4	washer 15
5	06209770	4	nut m 14
6	01127856	4	nut m 16, d985
7	16063118	4	screw m 16 x 70
8	06214217	4	washer 17
10.1	01174711	1	socket 7 pol.
10.2	01123583	3	screw m 5 x 35
10.3	06209765	3	nut m 5, d985
10.5	01172065	5	clamp 4.6 x 146

H9_97498_60_0-A-001

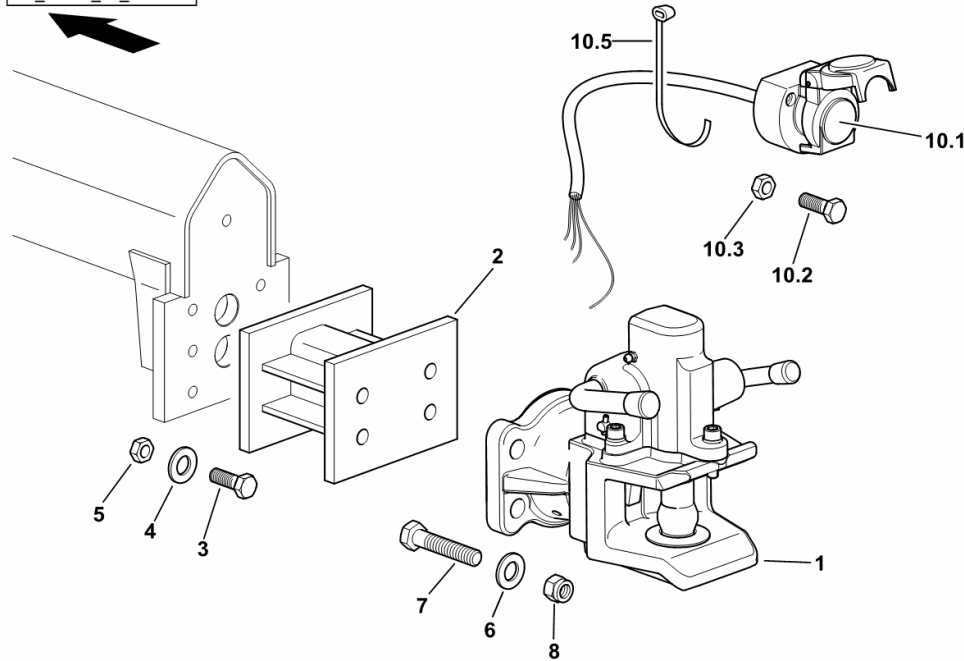

Section: HB - AXLES
SENSORS COVER

Fig.	Code	QTY	Name
------	------	-----	------

Notes:
 BALANCE/AUTOCONTROL [6090 ->14500]

17	16064237/10	1	sump
18	16064267/10	1	cover
19	16064246/10	1	support
20	16064242	3	disc
21	2.1310.004.2	11	flat washer 8.5
22	2.1474.009.2	7	spring washer 8
23	2.0114.209.2	4	screw m 8 x 25
24	2.0114.211.2	1	screw m 8 x 30
25	2.0114.207.2	2	screw m 8 p.1.25 x 20
26	16064244	4	hose clip
27	2.1120.005.2	2	nut m 8 p.1.25
28	2.0114.216.2	1	screw m 8 x 45
29	2.0114.213.2	1	screw m 8 x 35
30	16064243	1	disc

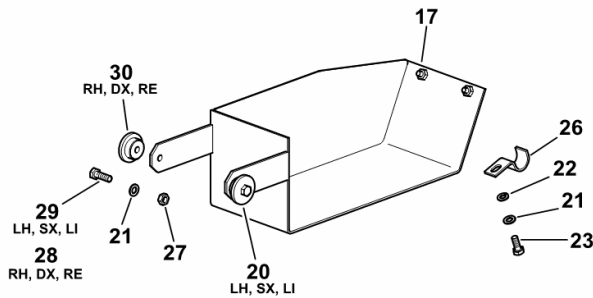
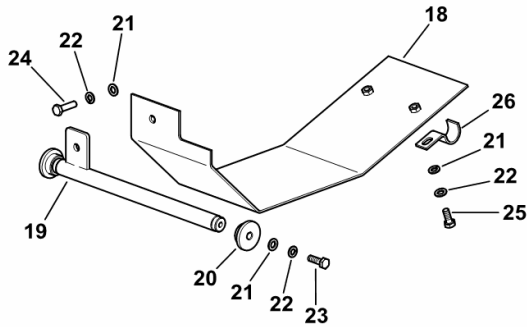

H9_Z75B2_10_0-B-001

DRIVE SHAFT TRANSMISSION

Fig.	Code	QTY	Name
1	16052943	1	cover dx/rh/re
2	16052944	1	'o' ring
3	01107755	1	ring 40 x 1,75, d471
4	01109132	1	ball bearing
5	16052945	1	ring
6	16052946	1	gear z=40
7	01168769	1	workshop tool k 65x73x30
8	16052947	1	ring
9	16052948	1	hub
10	16052949	1	sleeve
11	16052950	1	gear Z = 29
12	01145355	1	ring k 58x65x36
13	16052952	1	transmission shaft
14	2.2062.013.0	1	ball bearing 45x100x25
15	01107760	1	circlip 45x1.75
16	16052953	1	cover sx/lh/li
17	01107747	1	ring
18	16052954	1	gasket
19	16052955	1	cylindrical plug 12x20
20	16052956	1	body
21	01107105	15	washer 10.5
22	01148457	10	screw
23	01153355	1	screw 10 x 25
24	01127084	1	nut
25	01110653	4	screw
26	01102800	4	washer 10.2
27	01148130	4	screw

1604_0895_30_2

WHEEL HUB

Fig.	Code	QTY	Name
------	------	-----	------

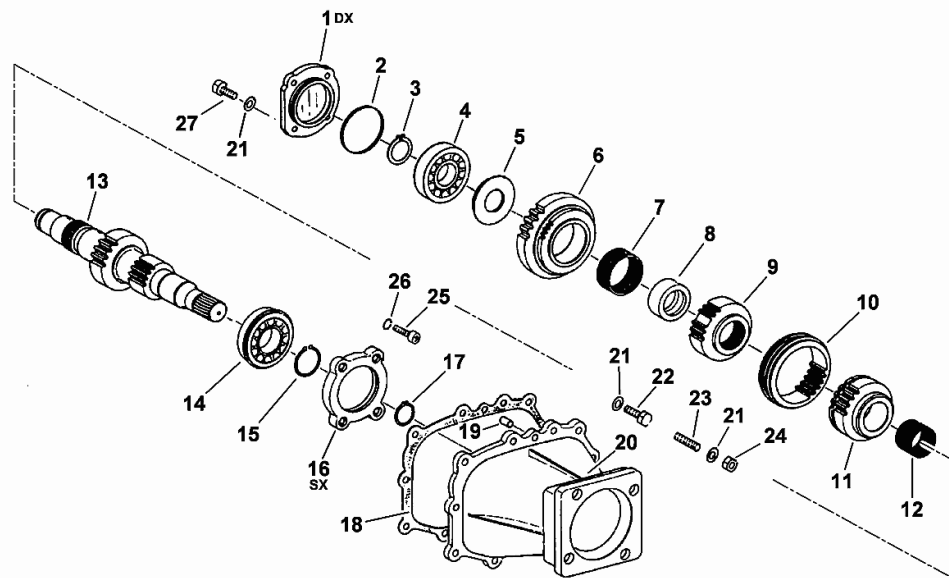
Notes:

[6090 ->14500]

1	16057142	1	wheel spindle kpl. (sx/lh/li)
1.2	16050726	1	'o' ring
1.3	01145966	1	bearing 33112
1.4	01110001	1	bearing 32207
1.5.1	16053719	1	hub
1.5.16	06238986	6	screw m 18 p.1.5
1.6	06514957	1	small cover
1.7	01143009	1	split pin 6.3 x 50
1.8	06209574	1	nut m 30 p.1.5
1.9	06214372	1	washer 30
1.11	16057140	1	wheel spindle sx/lh/li
2	0.016.7163.4	1	wheel spindle kpl. (dx/rh/re)
2.1	16050726	1	'o' ring
2.2	01145966	1	bearing 33112
2.3	01110001	1	bearing 32207
2.4.1	16053719	1	hub
2.4.16	06238986	6	screw m 18 p.1.5
2.5	06514957	1	small cover
2.6	01143009	1	split pin 6.3 x 50
2.7	06209574	1	nut m 30 p.1.5
2.8	06214372	1	washer 30
2.10	0.016.7163.3	1	wheel spindle dx/rh/re

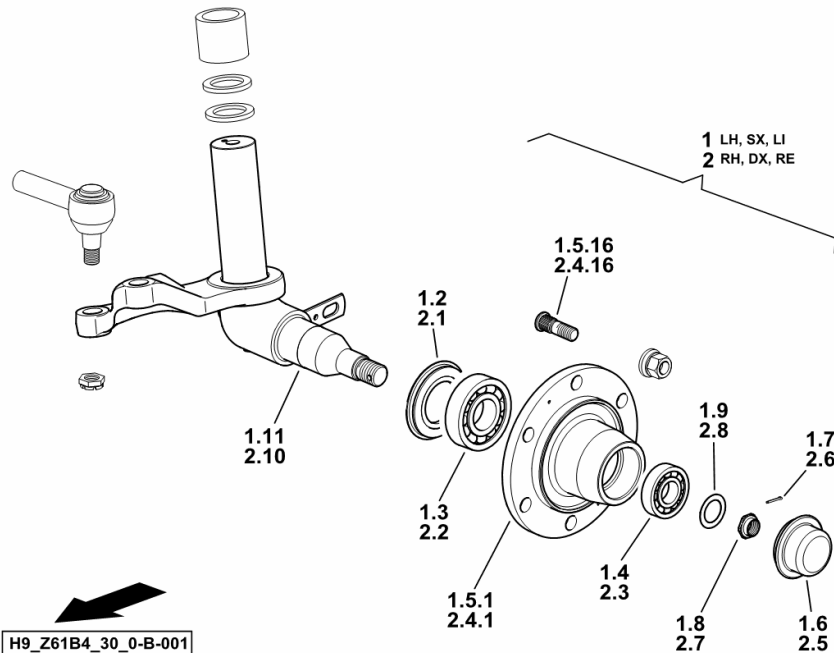

FRONT WHEELS 650/75 R32" 172A

Fig.	Code	QTY	Name
------	------	-----	------

Notes:
 ET+10 L, ET-30 R [6090 ->14500]

1	01146097	2	tyre 650/75 R32"
2	01141855	1	rim DWW 21Bx32" RIGHT-HAND SIDE
3	06212941	2	valve 50 msw
4	0.016.4689.3	1	rim DWW 21Bx32" LEFT-HAND SIDE

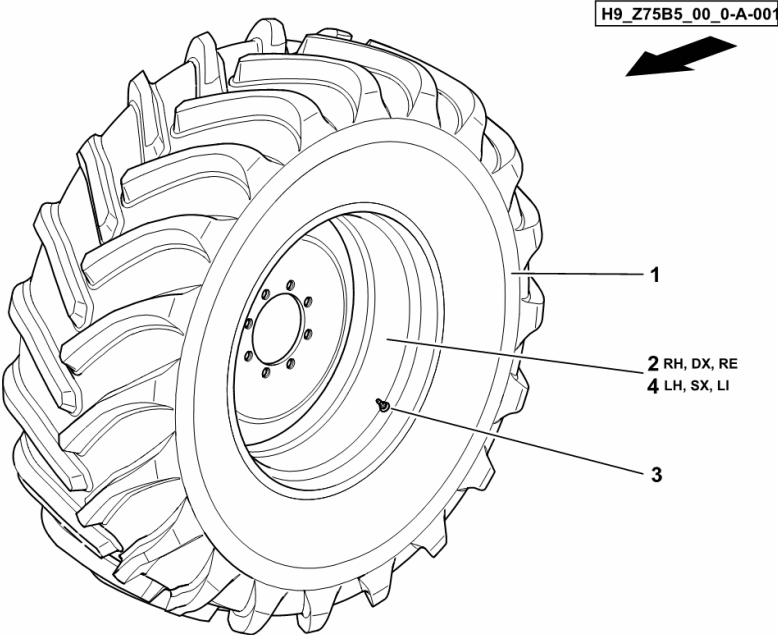

Section: HC - BELTS AND CHAINS
BELTS AND CHAINS - DX/RH/RE

Fig.	Code	QTY	Name
Notes: [6090 ->14500]			
1	01146033	1	belt STRAW CHOPPER DRIVE STRAW CHOPPER
2	0.900.1172.1	1	belt STRAW WALKER SHAFT 2 CHAFF SPREADER
3	16062738	1	belt 2hc x 3355 ENGINE POWER TAKE OFF STRAW CUTTER DRIVE
4	01145331	1	belt 30 x 15 x 1683Li STRAW WALKER DRIVE FAN VARIATOR
5	01145369	1	belt 30 x 15 x 1600Li FAN VARIATOR FAN
6	01145374	1	belt 63 x 25 x 2185Lw BEATER VARIATOR BEATER DRIVE
7	01145049	1	belt 3/17 x 2650Li BEATER DRIVE BEATER
8	16063211	1	belt 4hbm x 5205 ENGINE POWER TAKE OFF BEATER VARIATOR
9	01145055	1	belt 1hc x 5505La ENGINE PTO DRIVE GRAIN HOPPER OUTLET
10	01145072	1	chain 085-1x 68-E BEATER VARIATOR VARIATOR CONTROL DEVICE
11	16063413	1	chain 12A - 1 x 63 d8187 HOPPER FEED SCREW DRIVE
12	16062737/20	1	belt 2hc x 1737 ENGINE POWER TAKE OFF ENGINE POWER TAKE OFF DRIVE
13	16062841	1	belt 1/13 x 4022 ROTARY FILTER BASKET CONTROL
14	01146013	1	belt 1/17 x 2435Li COOLING FAN CONTROL
15	01116096	1	belt 1/17 x 2360 ASPIRATOR CONTROL

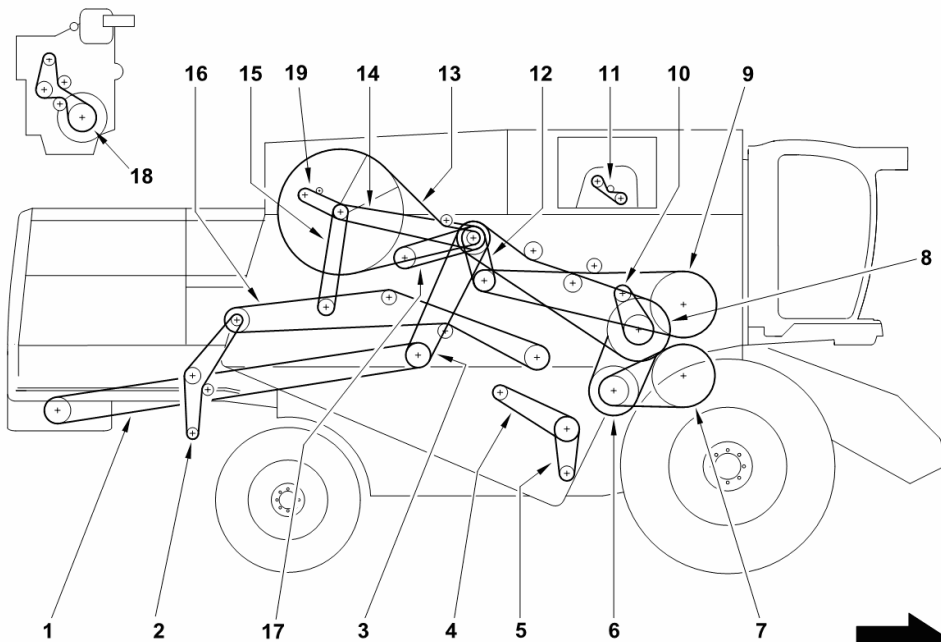

HATCH OPENING MECHANISM.....	HF.02.31 (2)
R.H. LINING.....	HF.02.32 (1)
R.H. LINING.....	HF.02.32 (2)
LOCK MECHANISM.....	HF.02.33 (1)
LOCK MECHANISM.....	HF.02.33 (2)
R.H. LINING.....	HF.02.34 (1)
R.H. LINING.....	HF.02.35 (1)
RH FRAME HINGE.....	HF.02.37 (1)
RH FRAME HINGE.....	HF.02.37 (2)
RH FRAME HINGE.....	HF.02.39 (1)
HATCH OPENING MECHANISM.....	HF.02.40 (1)
HATCH OPENING MECHANISM.....	HF.02.40 (2)
R.H. LINING.....	HF.02.41 (1)
R.H. LINING.....	HF.02.42 (1)
R.H. LINING.....	HF.02.42 (2)
LOCK MECHANISM.....	HF.02.43 (1)
LOCK MECHANISM.....	HF.02.43 (2)
RH REAR TRIM.....	HF.02.44 (1)
R.H. LINING.....	HF.02.45 (1)
R.H. LINING.....	HF.02.46 (1)
REAR WINDOW CATCH - DX/RH/RE.....	HF.02.48 (1)
RH REAR TRIM.....	HF.02.50 (1)
RH REAR TRIM.....	HF.02.50 (2)
STEP.....	HF.02.51 (1)
RH REAR TRIM.....	HF.02.53 (1)
RH REAR TRIM.....	HF.02.53 (2)
STRAW BOX.....	HF.02.55 (1)
STRAW BOX.....	HF.02.55 (2)
STRAW BOX.....	HF.02.57 (1)
SUPPORTS.....	HF.02.59 (1)
SUPPORTS.....	HF.02.61 (1)
cover plate.....	HF.02.63 (1)
STRAW RAKE.....	HF.02.65 (1)
GUARDS.....	HF.02.67 (1)
ENGINE AIR GUIDE.....	HF.02.68 (1)
ENGINE AIR GUIDE.....	HF.02.69 (1)
COVER PLATE.....	HF.02.71 (1)
ENGINE COVER SUPPORT.....	HF.02.73 (1)
ENGINE AIR GUIDE.....	HF.02.75 (1)
CHOCK.....	HF.02.76 (1)
SUPPORT.....	HF.02.77 (1)
HOLDING DEVICE - WHEEL CHOCK.....	HF.02.78 (1)
PROTECTION BAR.....	HF.02.80 (1)
GUARD PLATES.....	HF.02.82 (1)

Section: HF - CHASSIS- BODYWORK
FRONT LIGHTS SUPPORT

Fig.	Code	QTY	Name
------	------	-----	------

Notes:

[6090 ->14500] -> 14580

16	0.015.2519.2/10	1	diaphragm sx/lh/li
17	0.015.2517.0	1	diaphragm
18	0.015.2518.2/10	1	diaphragm dx/rh/re
20	0.015.2689.3/10	1	lamp support dx/rh/re
21	0.015.2688.3/10	1	lamp support sx/lh/li
29	2.0350.657.6	22	screw m 5.5 x 22
30	2.0312.702.2	4	screw m 4.0 x 12
31	2.1475.011.2	4	washer 4
32	2.1011.101.2	4	nut m 4 p.0.7
35	0.015.3871.0	1	support sx/lh/li
36	0.015.3872.0	1	support dx/rh/re
37	2.1310.002.2	32	washer 6.6, d125
38	0.015.2610.0	1	bracket sx/lh/li
39	0.015.2616.0	1	bracket dx/rh/re

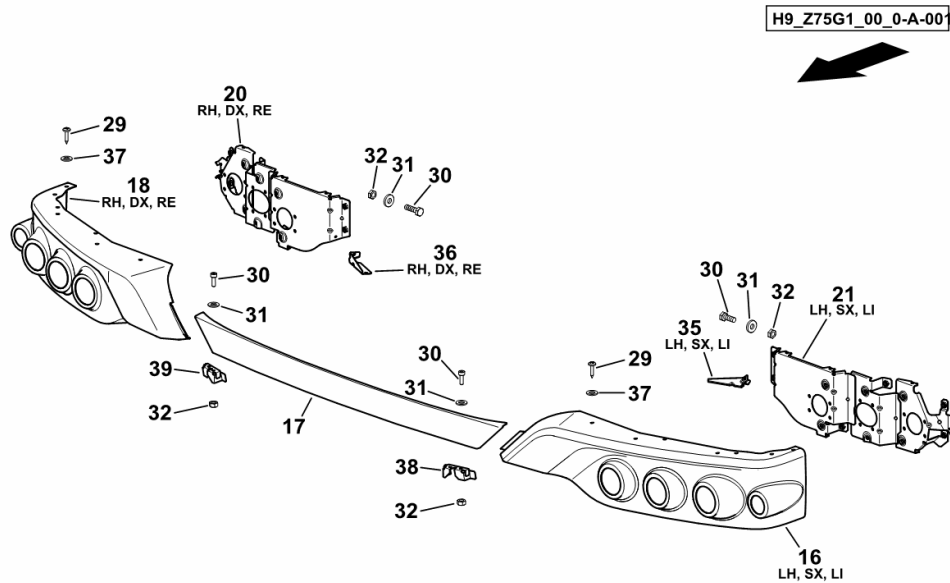

L.H. LINING

Fig.	Code	QTY	Name
------	------	-----	------

Notes:

[6090 ->14500]

2.1	0.017.0886.3	1	chassis frame
2.2	0.017.0890.0	1	cover
2.3	0.017.0892.0	1	rubber
2.4	0.017.2427.3/10	1	lamination
2.5	2.1310.004.2	7	flat washer 8.5
2.6	2.1012.105.7	11	nut m 8 p.1.25
2.7	01107165	4	washer 10.5
2.8	2.0020.203.2	4	screw m 8 x 16
2.9	0.017.3559.3	1	cover
2.10	0.017.0883.0	1	brace
2.11	2.3199.354.0	2	plug Ø 40 x 17
3	2.0114.209.2	10	screw m 8 x 25
4	2.1499.185.2/10	15	washer 12 x 20 x 3
5	2.1012.105.7	7	nut m 8 p.1.25
6	2.1310.004.2	7	flat washer 8.5
7	2.0114.207.2	5	screw m 8 p.1.25 x 20

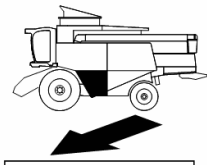
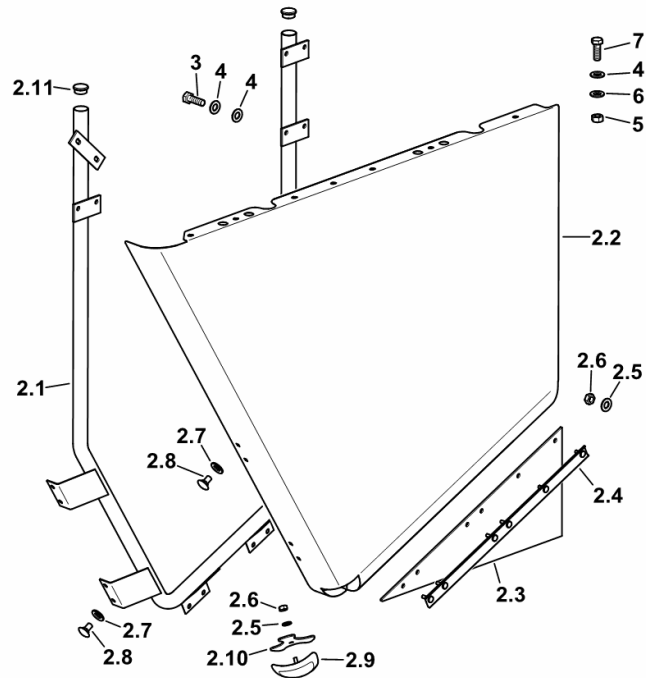

H9_Z75F2_10_0-A-001

L.H. LINING

Fig.	Code	QTY	Name
------	------	-----	------

Notes:

[6090 ->14500]

3	0.017.2423.0/10	1	cover
4	0.017.2424.0	1	plate
8	2.1499.185.2/10	24	washer 12 x 20 x 3
9	2.0114.207.2	24	screw m 8 p.1.25 x 20
10	2.1310.004.2	9	flat washer 8.5
11	2.1474.009.2	4	spring washer 8
12	2.1310.006.2	6	flat washer 10.5
13	2.1011.105.2	19	nut m 8 p.1.25
14	01141954	1	handle PVC
15	2.0020.203.2	10	screw m 8 x 16
16	2.0312.210.2	2	screw m 8 p 1.25 x 30

H9_Z75F2_00_0-B-001

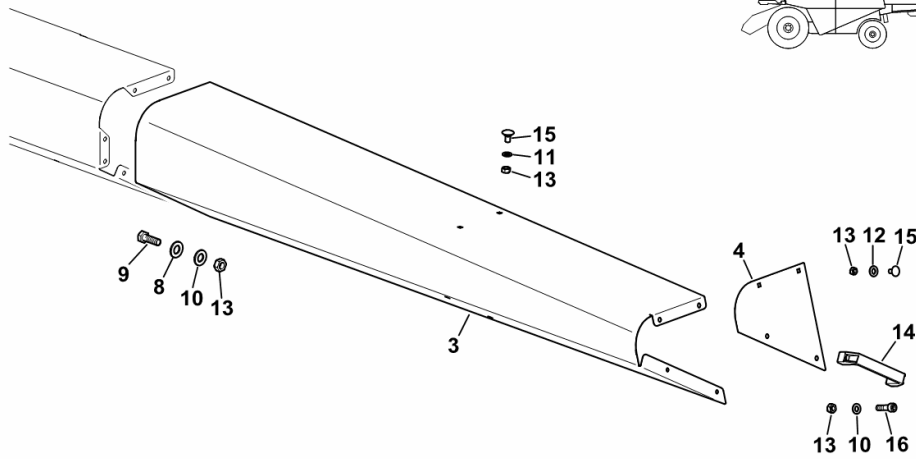
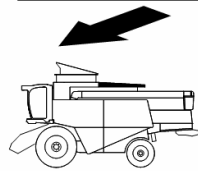

HATCH OPENING MECHANISM

Fig.	Code	QTY	Name
Notes:			
[6090 ->14500] 14588 <-			
1	0.017.3993.0	2	plate
2	0.018.0829.3/10	2	support
3	0.017.5234.4	2	shoch.absorber ☞ 0.017.5234.4
4	0.017.3997.0	2	pin Ø 15
5	2.1410.057.2	4	circlip 15
6	2.1312.008.2	2	washer 18x48
7	2.4019.823.1	2	spring
8	2.0319.035.0	2	screw L = MM 60 M8, Ø10
9	2.0319.036.0	2	screw L = MM 65 M8, Ø10
10	2.0114.209.2	8	screw m 8 x 25
11	2.1499.185.2/10	8	washer 12 x 20 x 3
12	2.1310.004.2	8	flat washer 8.5
13	2.1011.105.2	8	nut m 8 p.1.25
14	2.1120.005.2	4	nut m 8 p.1.25
15	2.1671.814.2	2	pin 18x50
16	2.1692.003.2	2	split pin m 4
17	0.017.5240.3	2	interlock
18	2.0319.037.0	2	screw L = MM 16 M8, Ø10
20	0.017.6823.4	1	rod dx/rh/re L = MM 1835 M4, Ø2
21	2.1310.006.2	2	flat washer 10.5
22	2.1549.689.2	2	spacer

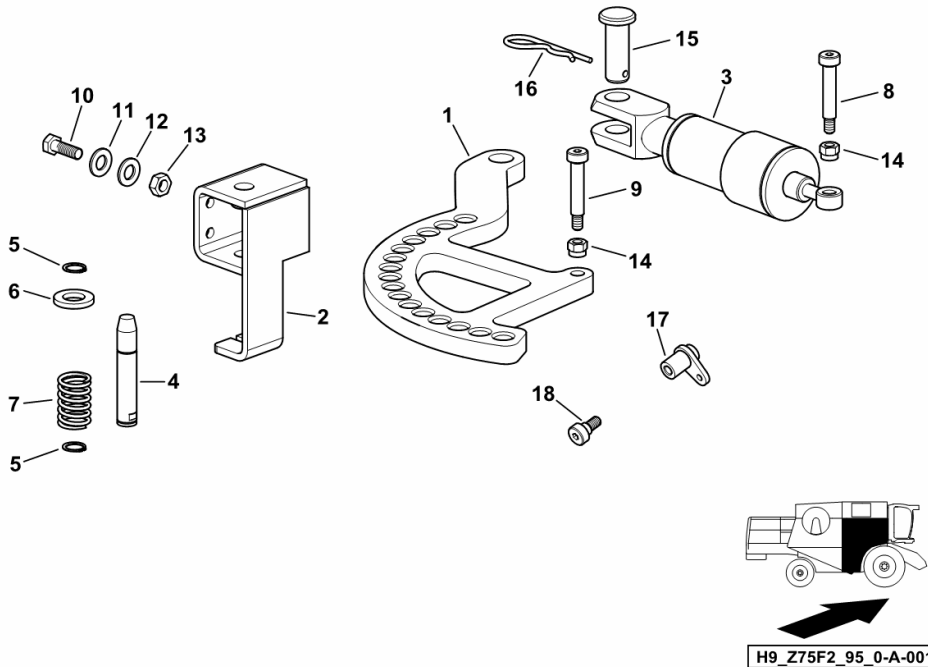

RH FRAME HINGE

Fig.	Code	QTY	Name
------	------	-----	------

Notes:

[6090 ->14500]

1	0.017.3206.0/10	2	pin
2	0.017.3207.0	2	smau pin m 8
3	0.017.3210.0	12	spacer
5	0.017.3212.0	2	spacer
6	0.017.3218.3/10	4	hinge
7	0.017.3221.3	4	plate
12	0.017.3972.3/10	4	plate
15	2.0113.315.2	12	screw m 10 x 40
16	2.0349.007.2	2	screw m 6 x 18
17	2.1012.106.7	22	nut m 10 p.1.5
19	2.1312.005.2	35	washer 10.2
21	2.3820.102.2	2	lubricator m 8 p.1x7
25	2.1310.006.2	12	flat washer 10.5
26	2.1474.010.2	32	washer 10

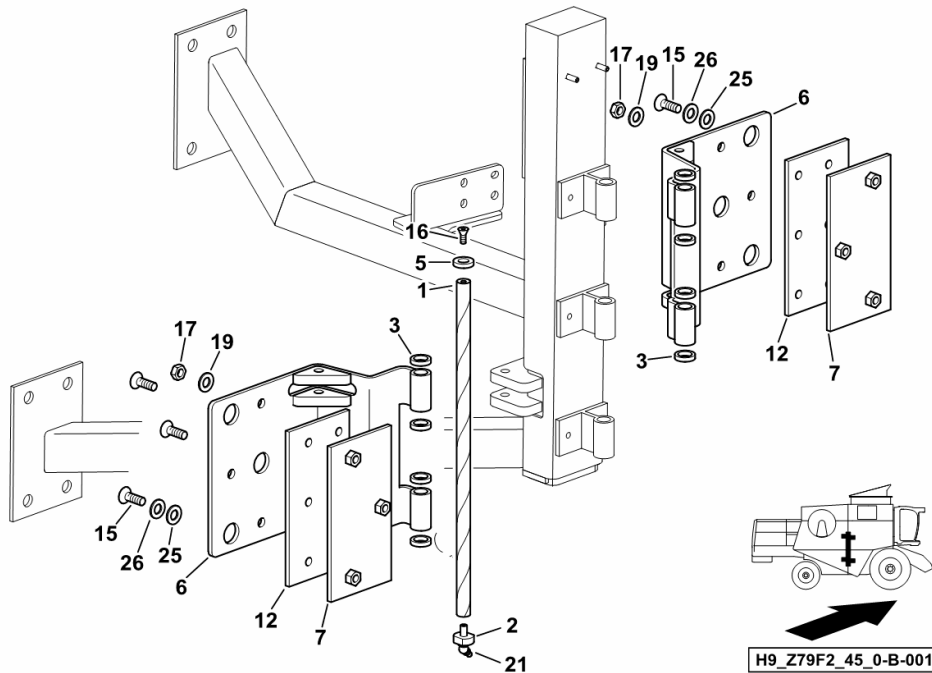

R.H. LINING

Fig.	Code	QTY	Name
------	------	-----	------

Notes:

[6090 ->14500]

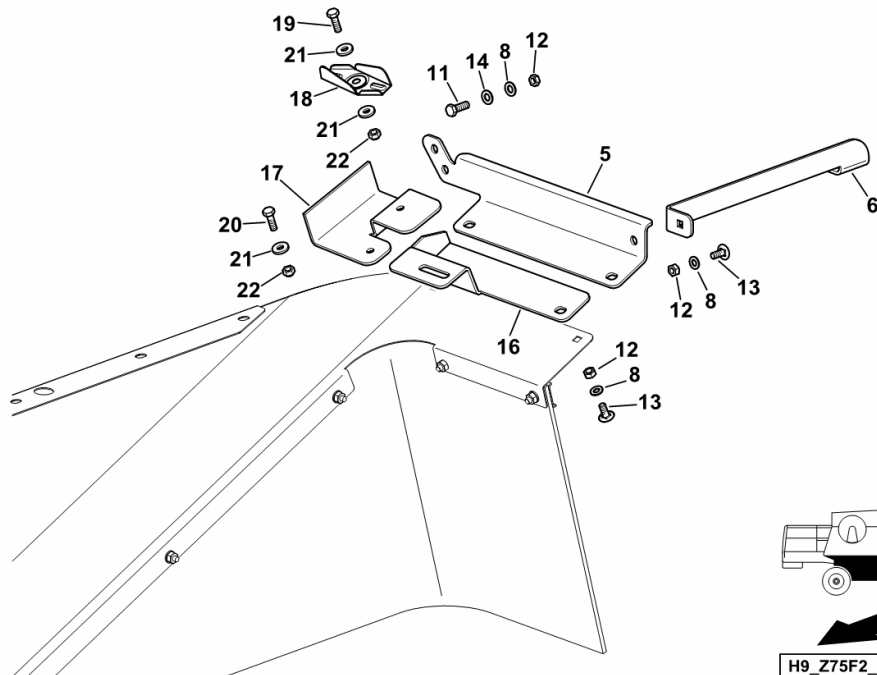

5	0.017.2474.0	1	bracket
6	0.017.2477.0	1	bracket
8	2.1310.004.2	30	flat washer 8.5
11	2.0114.209.2	12	screw m 8 x 25
12	2.1012.105.7	31	nut m 8 p.1.25
13	2.0020.205.2	7	screw m 8 p.1.25 x 20
14	2.1499.185.2/10	35	washer 12 x 20 x 3
16	0.017.7323.0	1	angular
17	0.017.7324.0	1	angular
18	06538985/10	2	interlock
19	2.0112.209.2	2	screw m 8 p 1.25 x 25
20	2.0112.207.2	1	screw m 8 p 1.25 x 20
21	06214192	5	washer 8.4
22	01104944	3	nut m 8, d985

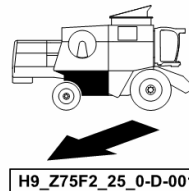

H9_Z75F2_25_0-D-001

SUPPORTS

Fig.	Code	QTY	Name
------	------	-----	------

Notes:
[6090 ->14500]

27	0.016.7351.0	1	sump
28	0.016.4275.0/10	1	support
29	2.0114.007.2	3	screw m 6 p.1 x 20
30	06214189	3	washer 6.4
31	01114357	3	nut m 6, d985

H9_Z79F3_00_0-B-001

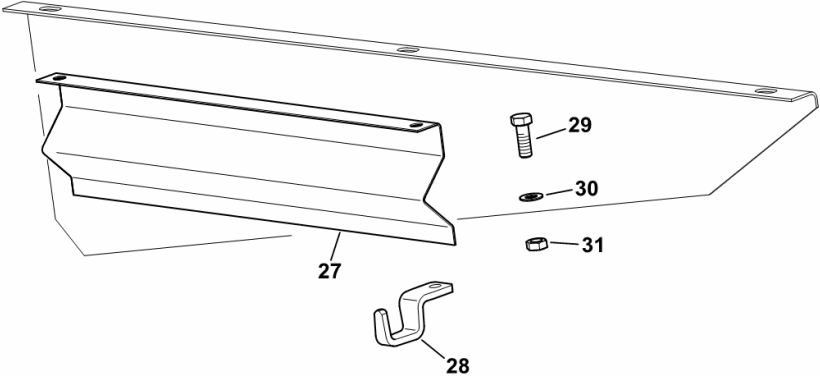



CHOCK

Fig.	Code	QTY	Name
------	------	-----	------

Notes:
[6090 ->14500]

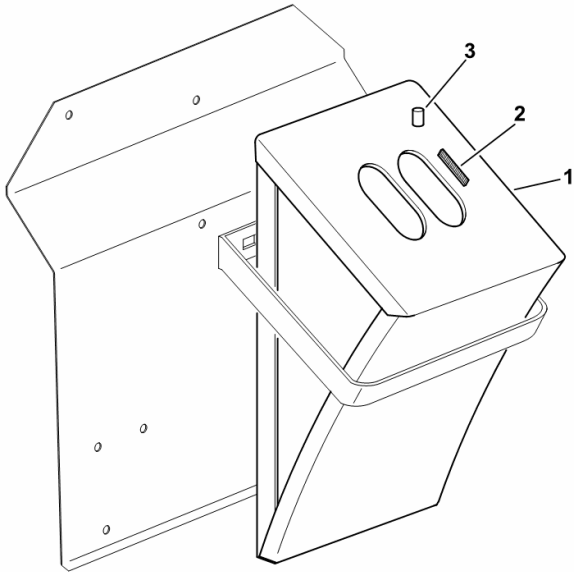
1	06508236	1	heelpiece
2	01390702	0.6	gasket PVC
3	06203303	1	rubber 6.9x9.5



H9_Z75F9_00_0-A-001

END COVERS

Fig.	Code	QTY	Name
------	------	-----	------

Notes:

[6090 ->14500]

1	2.3199.359.0	1	tube
2	2.0114.103.2	4	screw m 5 x 12
3	2.1474.006.2	4	spring washer 5
4	2.1011.102.2	4	nut m 5 p.0.7

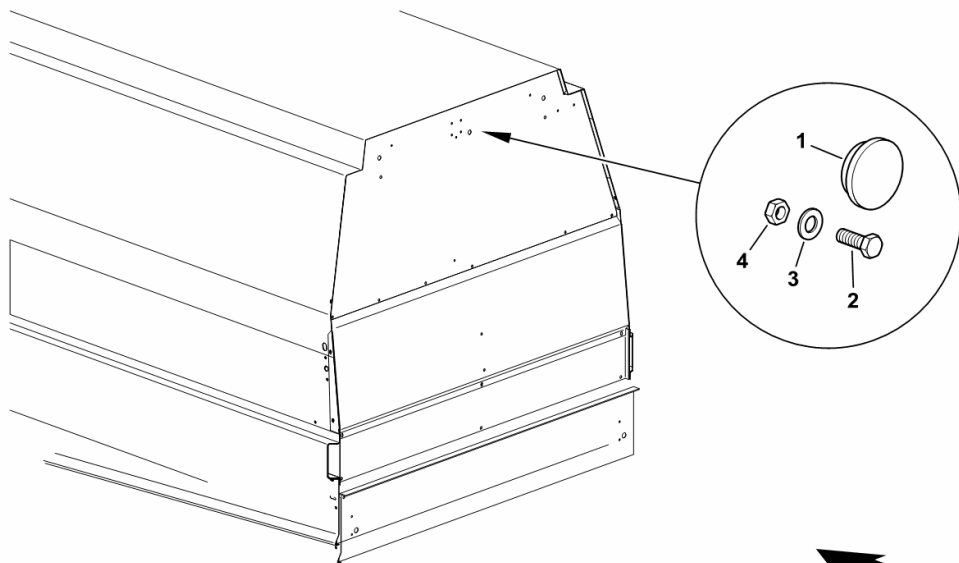

H9_Z57H5_42_0-A-001

LADDER

Fig.	Code	QTY	Name
------	------	-----	------

Notes:
[6090 ->14500]

6	16046763	2	rubber plate
7	16041128	1	foot board
8	16038751	1	small plate dx/rh/re
9	16041116	2	small plate
10	2.1474.009.2	9	spring washer 8
11	2.0114.213.2	8	screw m 8 x 35
31	2.1011.105.2	6	nut m 8 p.1.25
32	16038747	1	small plate sx/lh/li

H9_Z75G2_10_0-B-001

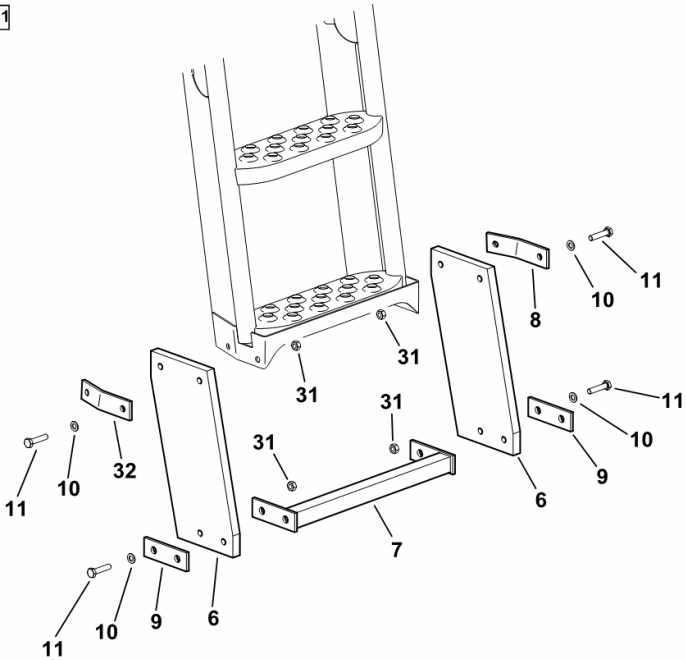

PRODUCT PLATE - REAR

Fig.	Code	QTY	Name
------	------	-----	------

Notes:
[6090 ->14500] -> 14684

1	0.017.6493.0	1	adhesive DEUTZ-FAHR
---	--------------	---	---------------------



H9_Z79F6_30_0-A-001

CUTTER BAR HYDRAULIC SYSTEM DATA PLATES

Fig.	Code	QTY	Name
------	------	-----	------

Notes:

[6090 ->14500]

1	2.9939.420.0	1	adhesive - BLACK
2	2.9939.419.0	1	adhesive - SILVER COLOUR
3	2.9939.418.0	1	adhesive - GREEN COLOUR

H9_Z33P5_21_0-A-001

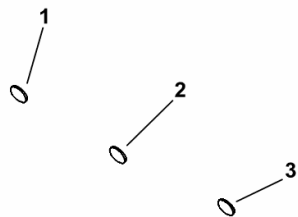

PLUGS

Fig.	Code	QTY	Name
------	------	-----	------

Notes:
[6090 ->14500]

1	0.012.6111.4	3	small cover
---	--------------	---	-------------

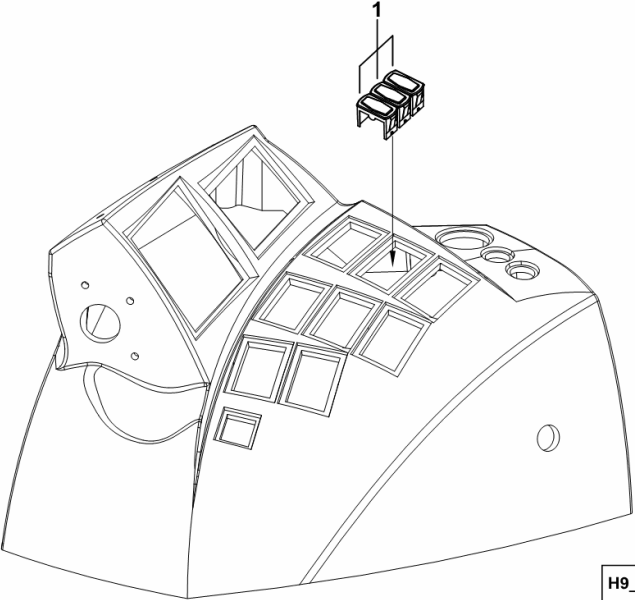

H9_Z7571_29_0-A-001

Section: HG - CAB
SUPPORT FOR MONITOR

Fig.	Code	QTY	Name
------	------	-----	------

Notes:

[6090 ->14500]

1	0.016.7466.0	1	support
2	2.0332.406.3	2	screw m 6 p.1.0 x 16
3	2.1310.002.3	2	flat washer 6.4 x 12 x 1.6
4	2.0332.102.2	2	screw m 3 x 8
5	2.1310.029.2	2	washer
6	2.6569.018.0	1	wire guide 20 x 8 x 15

H9_Z57H5_41_0-A-001

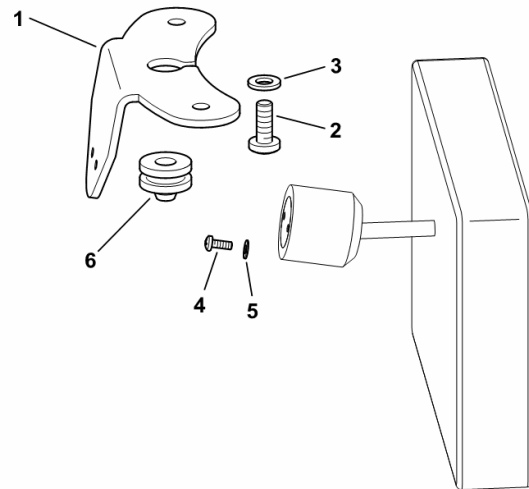

Section: HG - CAB
SEAT FOR 2ND OPERATOR

Fig.	Code	QTY	Name
------	------	-----	------

Notes:

[6090 ->14500]

1	0.016.4605.3/10	1	bracket
2	0.016.4600.3	1	bracket (14524 - 14525)
2	0.016.4600.3/10	1	bracket (-> 14523)
3	0.016.4599.3	1	seat support
4	0.016.4610.4	1	rail
6	2.0112.419.2	2	screw m 12 p.1.75 x 50
7	2.1120.007.2	2	nut m 12 p.1.75
8	16010252	1	hinge
10	16010231	1	small plate
11	2.0322.304.2	7	screw m 5 x 12
12	2.1120.002.2	2	selflock nut m 5
13	2.1310.004.2	2	flat washer 8.5
14	2.0312.202.2	2	screw m 8 p.1.25 x 12
15	01146036	4	pin 4.2 x 30
16	2.0114.105.2	2	screw m 5 x 16
17	2.1310.001.2	2	flat washer 5.3
18	16010229	1	lock
19	16010230	1	small spring
20	0.015.9392.0	1	seat
21	0.015.9564.4	1	embroiderhead

H9_Z5778_06_0-A-002

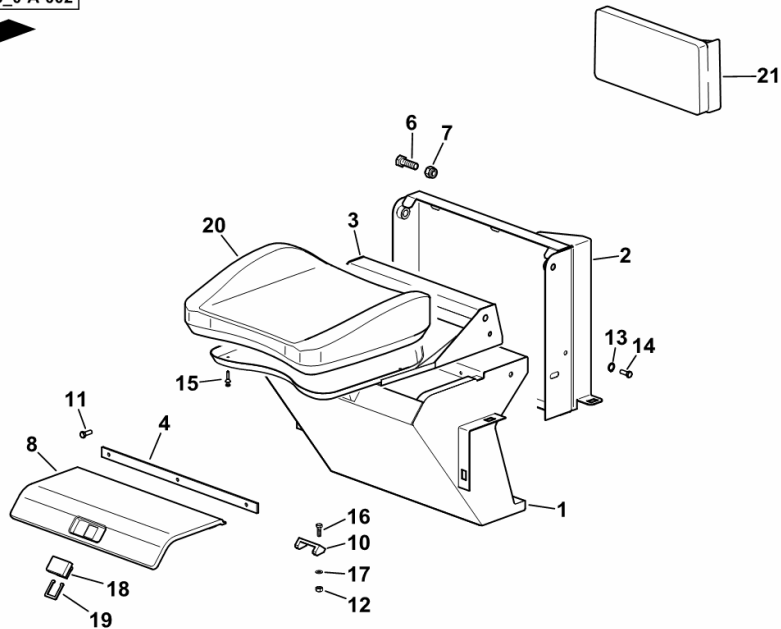

Section: HG - CAB
COVER PLATE

Fig.	Code	QTY	Name
------	------	-----	------

Notes:
[6090 ->14500]

26	16058722	1	cover
100	06209762	6	screw m 5 p.0.8 x 25
101	16058809	1	band

H9_Z5786_20_0-C-001

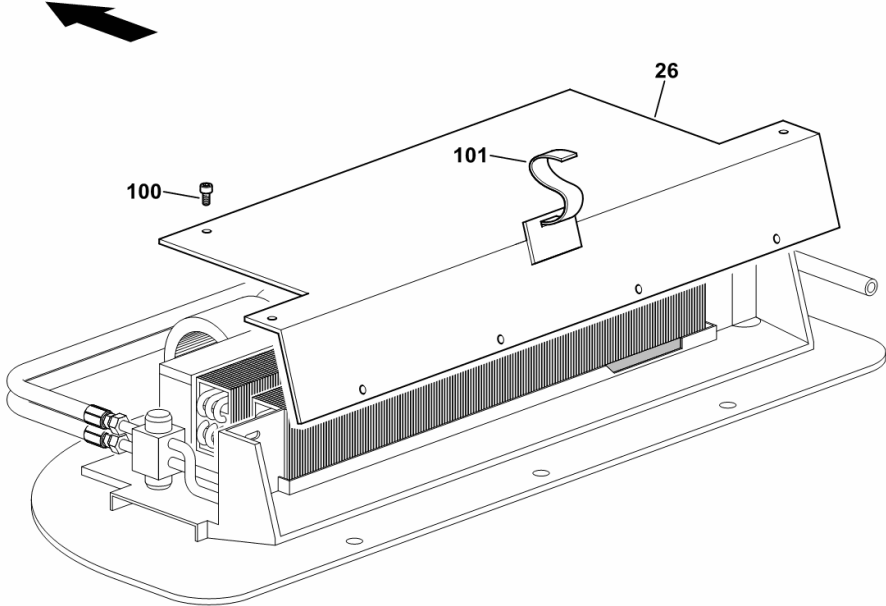

Section: HG - CAB

CONDENSER - AIR CONDITIONING UNIT

Fig.	Code	QTY	Name
------	------	-----	------

Notes:

[6090 ->14500]

1.2.1	16061770	1	support
1.2.3	16019682	1	flexible hose Ø 13.7 / L = mm 2150
1.2.4	06214679	1	ring 3/4 "
1.2.5	16021570	1	tube 5/8" / L = mm 3520
1.2.6	04322184	1	rubber plug 5/8"
1.2.7	16048397	1	support
1.2.8	01112418	2	screw m 10 x 25, d933
1.2.9	06209768	2	nut m 10, d985
1.2.10	06253864	1	silent-block
1.2.11	01114357	6	nut m 6, d985
1.2.13	04325384	1	clamp 19 x 23
1.2.14	06216402	1	clamp 15,9 ne
1.2.15	01112322	2	screw m 8 p.1.25 x 20
1.2.16	01104944	2	nut m 8, d985
1.2.17	16055624	1	condenser
1.2.18	01103316	1	screw m 6 p.1.0 x 16
1.2.19	01123749	1	screw m 6 x 25
1.2.20	06214189	17	washer 6.4
1.2.21	01127031	2	screw m 6 x 30, d933
1.2.22	16061767	1	support
1.2.23	16064219	1	shim

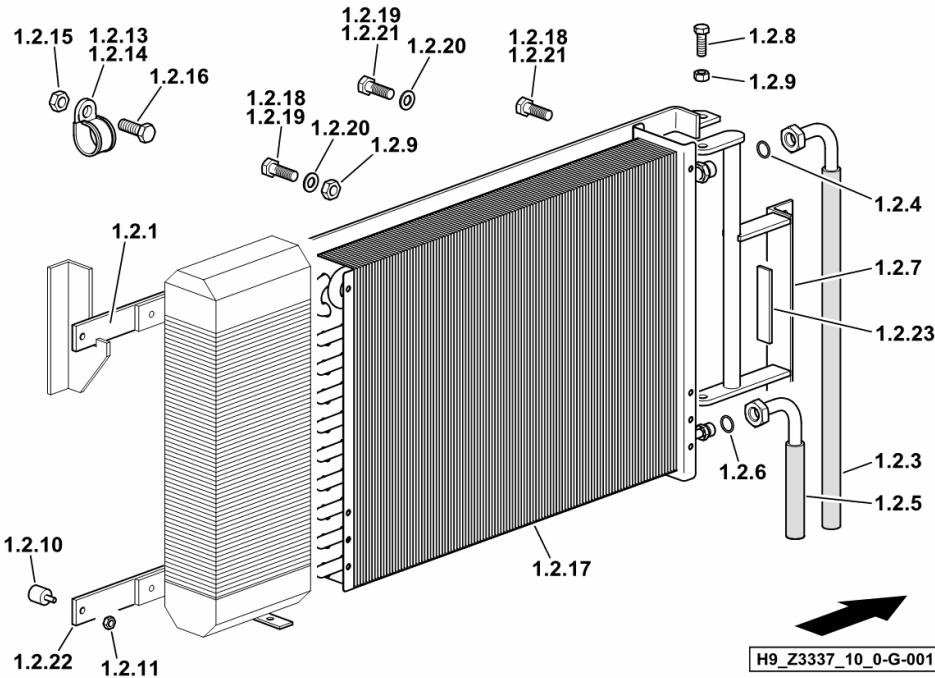

Section: HG - CAB

STEERING WHEEL TRIM DEUTZ-FAHR

Fig.	Code	QTY	Name
------	------	-----	------

Notes:

[6090 ->14500]

4	04395210	1	plug DEUTZ-FAHR
---	----------	---	-----------------

H9_Z5761_00_0-B-001

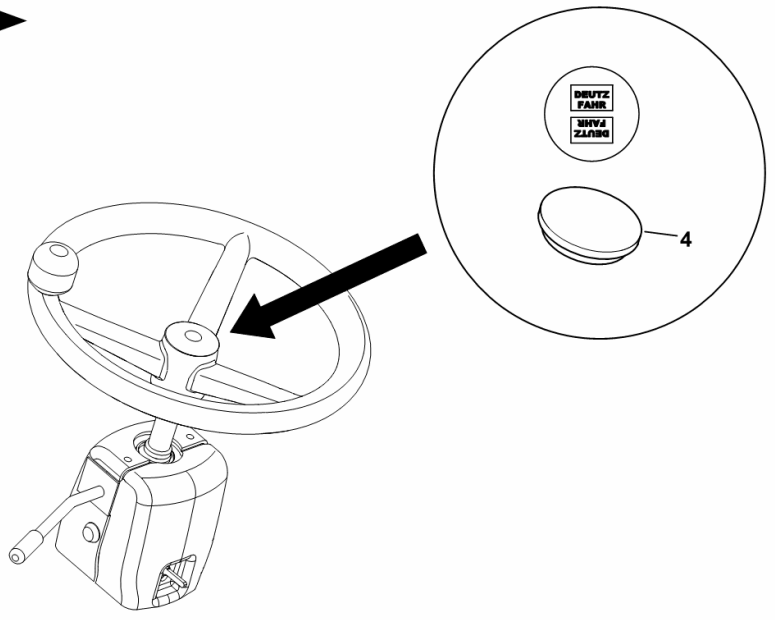

Section: HL - CLEANER UNIT
STRAW WALKERS

Fig.	Code	QTY	Name
------	------	-----	------

Notes:
 [6090 ->14500]

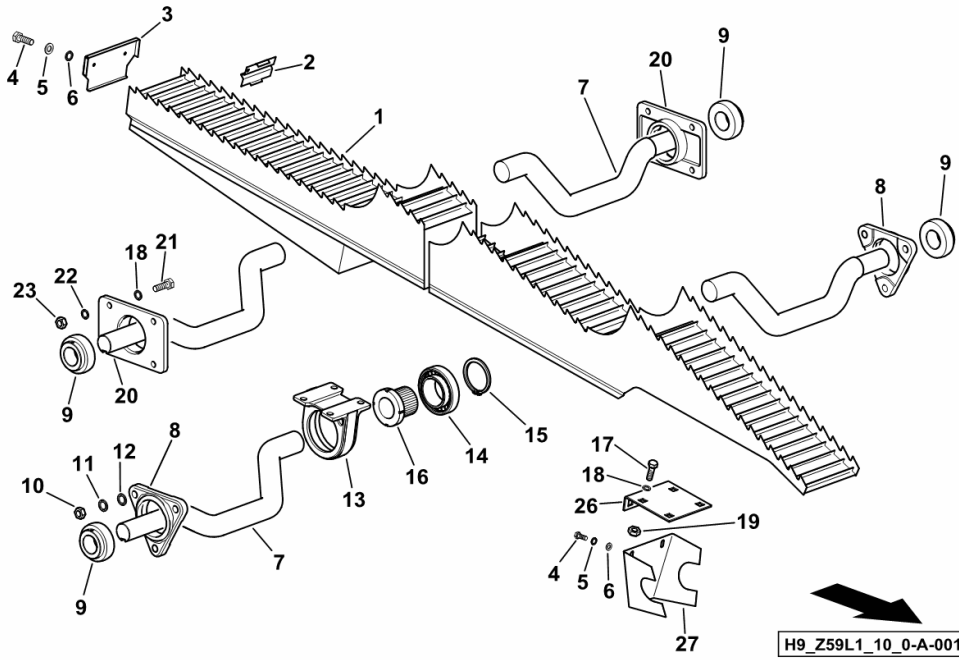

1	0.016.4162.3	6	shaker
2	06261363	18	small cover
3	16047883	6	small cover
4	2.0114.003.2	24	screw m 6 p.1 x 12
5	2.1474.007.2	48	washer 6, d128
6	2.1310.002.2	40	washer 6.6, d125
7	06302190	2	shaft
8	06263693	2	SET = 2 PIECES bearing block d35
9	06215759	4	bearing ys 35
10	2.1120.007.2	6	nut m 12 p.1.75
11	2.1474.011.2	6	spring washer 12
12	06214273	4	washer 13
13	06296514	12	bearing block
14	06215780	12	ball bearing k 50
15	2.1411.036.7	12	disc 90x3
16	06519305	12	power control 40 get.
17	2.0114.311.2	48	screw m 10 p.1.25 x 30
18	06214197	56	washer 10.5
19	2.1120.106.2	48	nut m 10 p.1.25
20	06513788	2	bearing block
21	2.0114.313.2	8	screw m 10 x 35
22	2.1474.010.2	8	washer 10
23	2.1011.106.2	8	nut m 10 p.1.5
26	06261394	6	plate
27	06261367	6	cover

Section: HL - CLEANER UNIT
STRAW-WALKER GEAR SX/LH/LI

Fig.	Code	QTY	Name
------	------	-----	------

Notes:

[6090 ->14500] -> 14523

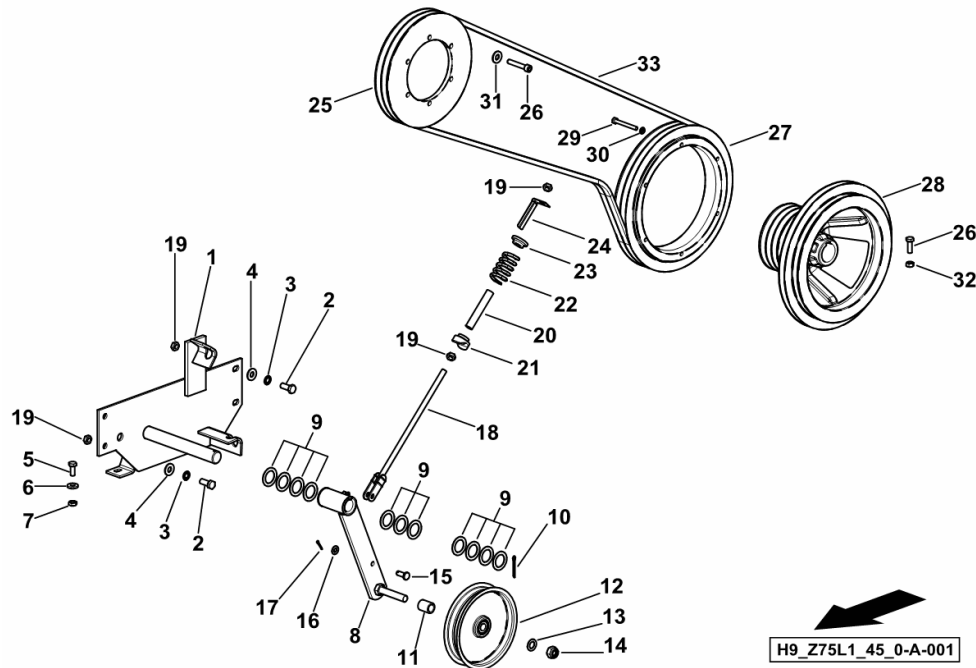

1	16006263/10	1	plate
2	2.0114.411.2	4	screw m 12 p.1.75 x 30
3	2.1474.011.2	4	spring washer 12
4	06214273	4	washer 13
5	2.0114.309.2	1	screw m 10 p 1.25 x 25
6	01127538	1	washer 10.5
7	06209768	1	nut m 10, d985
8	16006252	1	support
9	06214234	8	disc 31 x 45 x 2
10	2.1690.514.2	1	split pin 5 x 40
11	06233233	1	bushing 25 x 19 x 31
12	06260597	1	tensioner 40/200
13	01174923	1	washer 17
14	01127856	1	nut m 16, d985
15	2.1671.407.2	1	pin 10 x 28
16	2.1310.006.2	1	flat washer 10.5
17	2.1690.308.2	1	split pin 3.2 x 20
18	06501950/10	1	connecting rod
19	2.1011.107.2	4	nut m 12 p.1.75
20	06511966/10	1	tube
21	06519261/10	1	disc
22	06215418/10	1	spring 6,0 x 35,0 x 82
23	06515117	1	disc
24	16046800	1	lamination
25	16000658	1	pulley 2/17 x 280
26	2.0114.311.2	7	screw m 10 p.1.25 x 30
27	0.018.1017.0	1	pulley
28	0.017.5876.0	1	pulley
29	2.0112.223.2	6	screw m 8 p.1.25x70
30	2.1474.009.2	6	spring washer 8
31	2.1474.010.2	6	washer 10
32	2.1011.106.2	1	nut m 10 p.1.5
33	01145051	1	belt 2/17x2935li

MOVEMENT CONTROL

Fig.	Code	QTY	Name
------	------	-----	------

Notes:

[6090 ->14500]

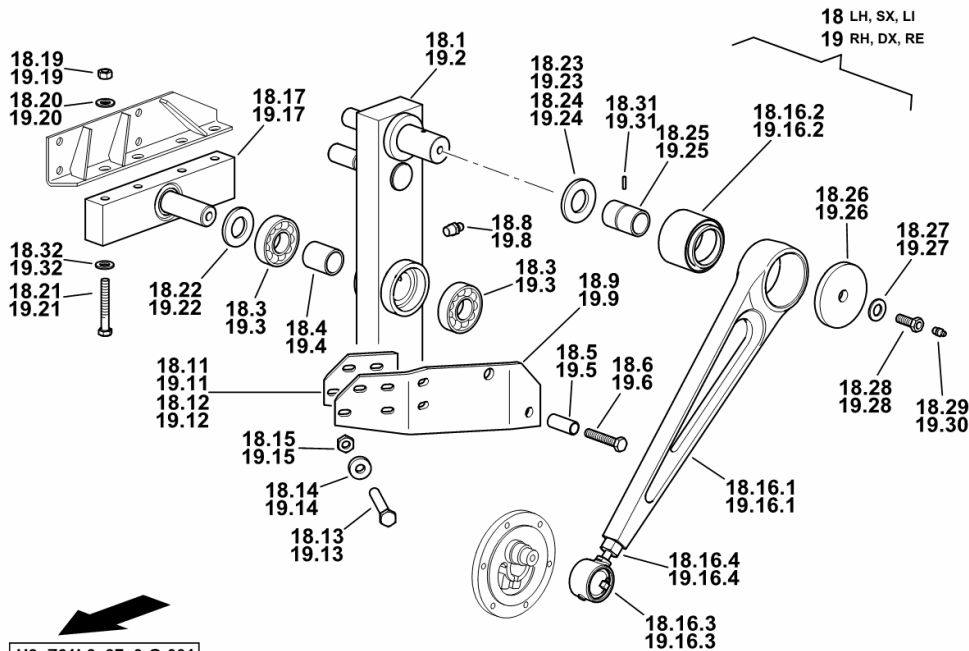

18.1	16043725/10	1	spring rockerarm sx/lh/li
18.3	01136765	2	ring 6207 rs d625
18.4	16041418	1	bushing
18.5	16040928/10	1	spacer
18.6	16061802	1	screw m 14 x 60
18.8	01120693	1	lubricator am 8 x 1
18.9	16039884	1	link sx/lh/li
18.11	16042295	1	lamination mm 3.00
18.12	16042296	1	lamination mm 1.00
18.13	01112429	6	screw m 10 x 30, d933
18.14	01102800	6	washer 10.2
18.15	06214197	6	washer 10.5
18.16.1	0.015.3210.0	1	rod
18.16.2	16013085	1	bearing
18.16.3	16011695/10	1	bearing kpl. ⚙️ 16011695/10
18.16.4	01133798	1	nut m 20 x 1.5
18.17	16038612	1	support
18.19	06209778	4	nut m 12
18.20	06214206	4	washer 13.2
18.21	06209115	4	screw m 12 x 120
18.22	01137526	2	shim 35 x 45 x 2,5
18.23	06214513	1	shim 60 x 75 x 0,2
18.24	06214515	1	shim 60 x 75 x 0,5
18.25	16013091	1	bushing 45 x 59,5 x 77
18.26	16043791/10	1	disc 13 x 71 x 8
18.27	01102801	1	washer 12
18.28	16013117	1	screw m 12 x 35
18.29	01120692	1	lubricator am 6
18.31	01115453	1	pin 6 x 24
18.32	16012311	4	washer 13
19.2	16043724/10	1	spring rockerarm dx/rh/re
19.3	01136765	2	ring 6207 rs d625
19.4	16041418	1	bushing
19.5	16040928/10	1	spacer
19.6	16061802	1	screw m 14 x 60
19.8	01120693	1	lubricator am 8 x 1
19.9	16039885	1	link dx/rh/re
19.11	16042295	1	lamination mm 3.00
19.12	16042296	1	lamination mm 1.00
19.13	01112429	6	screw m 10 x 30, d933

Section: HL - CLEANER UNIT
BOTTOM SIEVE BOX

H9_Z61L3_37_0-E-001

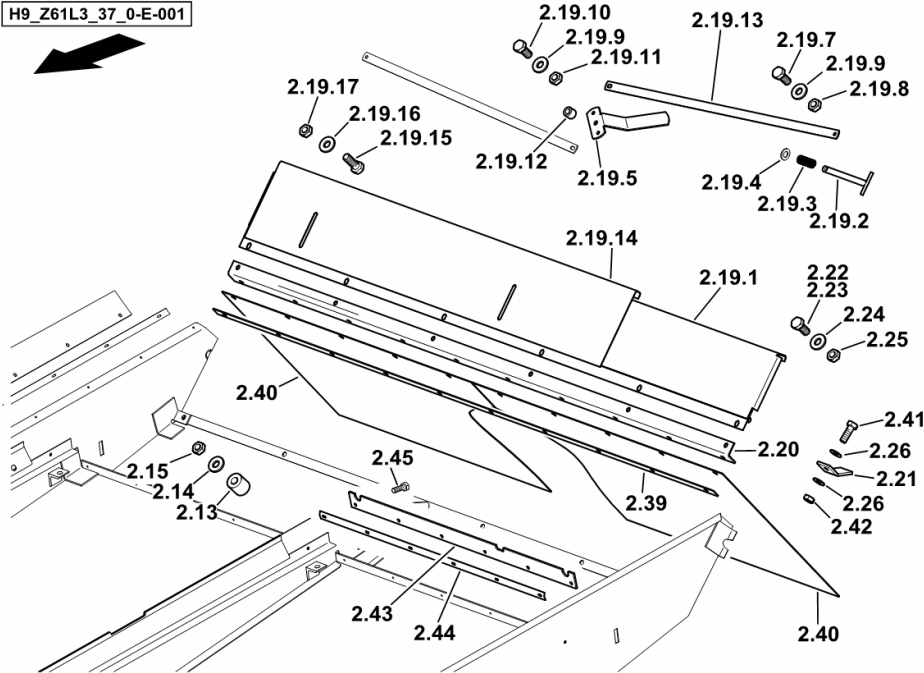

Fig.	Code	QTY	Name
Notes:			
[6090 ->14500]			
2.13	06240422	4	spacer
2.14	01174910	4	washer 9
2.15	01104944	4	nut m 8, d985
2.19.1	16054023	1	rear panel
2.19.2	16001056/10	2	pin
2.19.3	06215310	2	spring
2.19.4	01123616	2	washer 13.5
2.19.5	0.016.5917.0	1	lever
2.19.7	01123749	2	screw m 6 x 25
2.19.8	01114357	2	nut m 6, d985
2.19.9	06214189	4	washer 6.4
2.19.10	01112264	2	screw m 6 x 20, d933
2.19.11	01114357	2	nut m 6, d985
2.19.12	06250003	1	spacer Ø 11 / Ø 20 x 16
2.19.13	06545468	2	metal strap
2.19.14	16052028	1	lamination
2.19.15	01112307	3	screw m 8 p.1.25 x 15, d933
2.19.16	01126329	3	washer 8.4
2.19.17	01104944	3	nut m 8, d985
2.20	16011355	1	frame
2.21	16012432	4	support
2.22	01112322	2	screw m 8 p.1.25 x 20
2.23	01112333	4	screw m 8 x 25, d933
2.24	01107163	6	washer 9, d126
2.25	01112824	6	nut m 8, d934
2.26	01102799	6	washer 8, d128
2.39	16011359	1	band
2.40	16011357/10	2	plate
2.41	01112311	10	screw m 8 x 18
2.42	01104944	10	nut m 8, d985
2.43	16046576	2	hood
2.44	16046574	2	metal strap
2.45	01127683	12	screw m 4.2x13

Section: HL - CLEANER UNIT
ADJUSTABLE UPPER SIEVE T29

Fig.	Code	QTY	Name
------	------	-----	------

Notes:
- MAIZE EQUIPMENT [6090 ->14500]

1	16013164	2	adjustable sieve T29
---	----------	---	----------------------

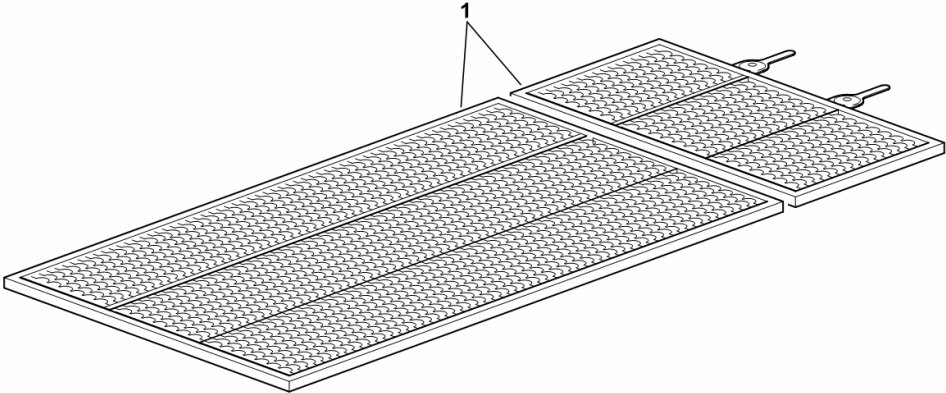

Section: HL - CLEANER UNIT
ADJUSTABLE LIFT ROD PARTS

Fig.	Code	QTY	Name
1	0.017.0098.4	1	adjustable tensioner kit, (6 SW) BOTTOM
2	0.900.1192.0	4	rod (-)
5	0.900.1192.5	1	stay kit
6	0.000.0000.1	0	not serviceable

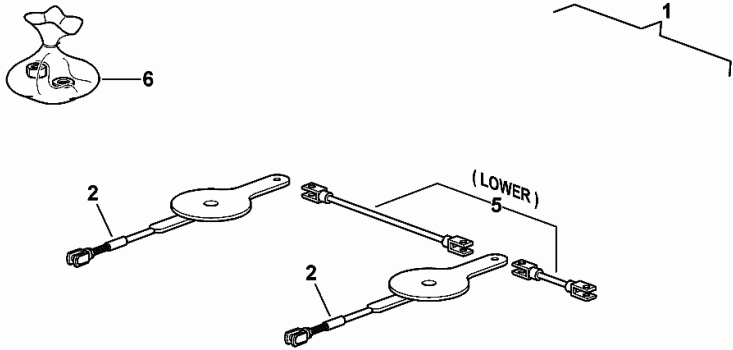

0_017_0098_4

V-BELT - PULLEY

Fig.	Code	QTY	Name
------	------	-----	------

Notes:

[6090 ->14500]

7	06296526	1	tensioner
8	06253492	1	tensioner 25,4 / 159
9	06282579	1	support
10	01145052	1	belt 1/17 x 3300
16	01118263	2	dowel 8 x 7 x 50, d6687
21	01112322	1	screw m 8 p.1.25 x 20
22	01112824	4	nut m 8, d934
23	01107163	5	washer 9, d126
24	01102799	4	washer 8, d128
25	01111941	1	screw m 16 x 120
26	01107117	1	washer 17
27	0.016.2808.0	1	spacer
28	06546690/10	1	bushing
29	01127856	1	nut m 16, d985
32	01103316	4	screw m 6 p.1.0 x 16

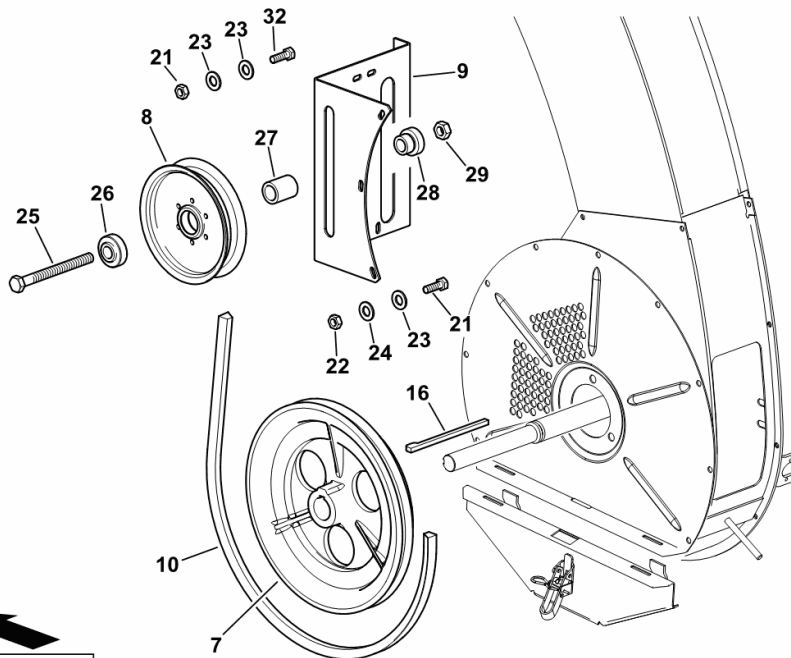

H9_Z75L8_00_0-A-001

Section: HL - CLEANER UNIT

COVER - DX/RH/RE

Fig.	Code	QTY	Name
------	------	-----	------

Notes:

[6090 ->14500]

6	06508392	1	complete cover dx/rh/re
6.1	06506853/10	1	cap
6.2	06508627/10	1	insert
6.3	01108524	2	screw m 8 p.1.25 x 20
6.4	01112824	4	nut m 8, d934
6.5	01102799	3	washer 8, d128
6.6	01107163	5	washer 9, d126
6.10	01139118	1	chain fi 2,8 x 468, d5686
6.11	01138823	1	screw m 8 x 30
22	2.1474.007.2	21	washer 6, d128
23	01112813	21	nut m 6
29	01103316	1	screw m 6 p.1.0 x 16
30	06214189	8	washer 6.4

H9_Z75L8_01_0-C-001

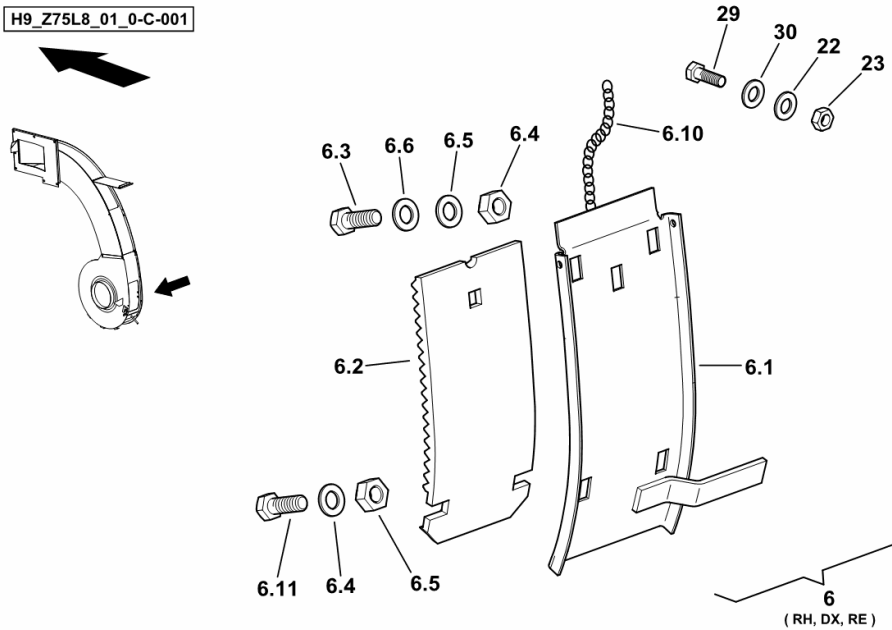

Section: HP - CUTTER BAR
CARDAN SHAFT L = MM 1360

Fig.	Code	QTY	Name
------	------	-----	------

Notes:
[6090 ->14500]

1	16019372	1	universal joint L = mm 1360
---	----------	---	-----------------------------

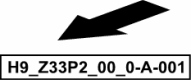
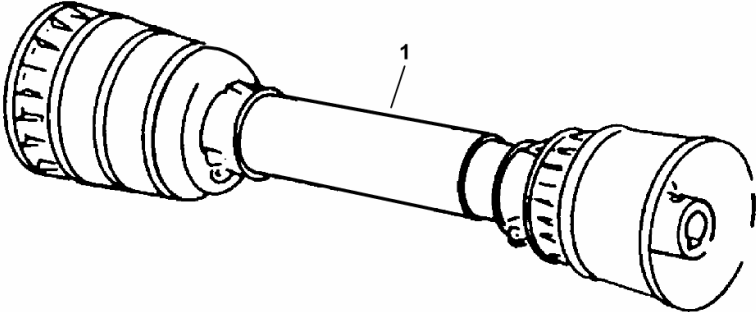

Section: HP - CUTTER BAR
SUPPORT DX/RH/RE (MT. 5,4 / MT. 7,2)

Fig.	Code	QTY	Name
------	------	-----	------

Notes:
- SUNFLOWER EQUIPMENT [6090 ->14500]

1	16064039	1	carrier dx/rh/re
2	01111319	2	screw m 10 x 60
3	01140501	2	washer 10.5
4	06209768	2	nut m 10, d985
5	06209769	2	nut m 12, d985
6	01112429	2	screw m 10 x 30, d933
7	01140501	2	washer 10.5
8	06209768	2	nut m 10, d985

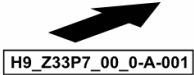
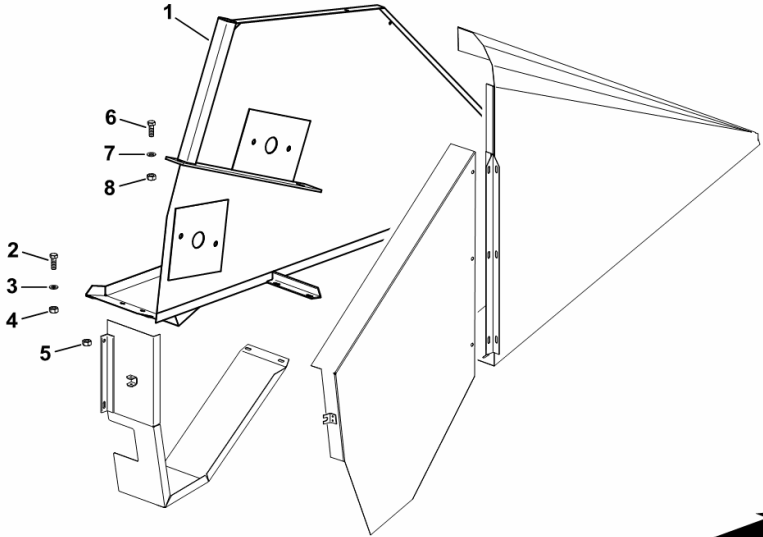

Section: HP - CUTTER BAR
SHAFTS - MT. 6,3

Fig.	Code	QTY	Name
------	------	-----	------

Notes:
- SUNFLOWER EQUIPMENT [6090 ->14500]

1	16064050	1	shaft L = mm 6300 ABOVE
2	16064051	1	shaft L = mm 6300 BOTTOM

H9_Z33P7_21_0-A-001

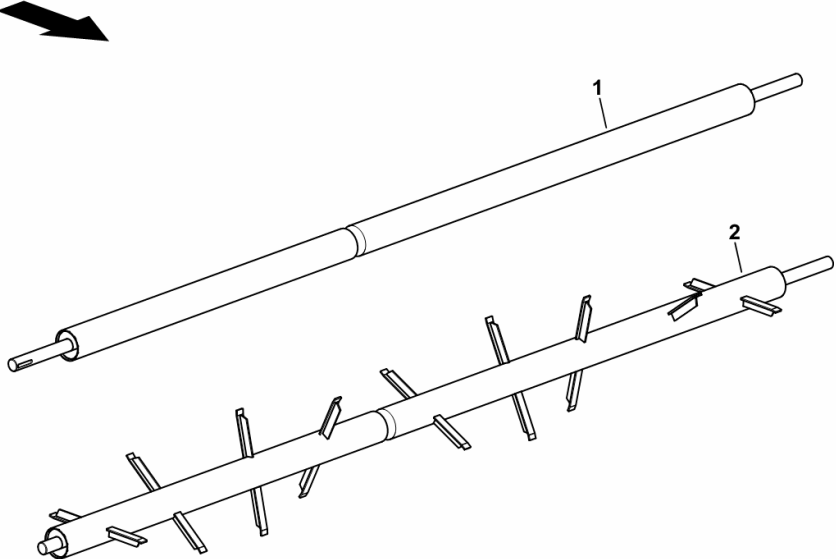

6090 ->14500

HH - ELECTRICAL SYSTEM

BATTERY

BATTERY.....	HH.01.0 (1)
GUARD PLATE.....	HH.01.1 (1)

WIRING HARNESSSES

FRONT LIGHTS WIRING.....	HH.02.0 (1)
RIGHT-HAND CONSOLE ELECTRICAL SYSTEM.....	HH.02.2 (2)
ELECTRICAL WIRING.....	HH.02.3 (1)
ELECTRICAL CLIMATE CONTROL SYSTEM.....	HH.02.4 (1)
WORK LIGHT WIRING.....	HH.02.5 (1)
WORK LIGHT WIRING.....	HH.02.6 (1)
MAINTENANCE LIGHTS WIRING.....	HH.02.7 (1)
FUSEBOX.....	HH.02.8 (1)
FUSEBOX DOOR.....	HH.02.9 (1)
ELECTRICAL EQUIPMENT ENGINE TCD 2013 L06-4V.....	HH.02.11 (1)
ELECTRICAL EQUIPMENT ENGINE TCD 2013 L06-4V.....	HH.02.13 (1)
ALTERNATOR CABLE.....	HH.02.15 (1)
ELECTRICAL EQUIPMENT ENGINE.....	HH.02.17 (1)
ENGINE CONTROL UNIT BOX.....	HH.02.19 (2)
CONNECTORS.....	HH.02.21 (1)
ELECTRICAL EQUIPMENT CHASSIS.....	HH.02.23 (1)
ELECTRICAL SYSTEM (EV).....	HH.02.24 (1)
ROTATION ANGLE SENSOR ELECTRICAL SYSTEM.....	HH.02.26 (1)
WIRING FOR ELECTRIC MOTOR CONTROL.....	HH.02.27 (1)
POWER OUTLET SOCKET.....	HH.02.28 (1)
REVERSER DEVICE ELECTRICAL SYSTEM.....	HH.02.29 (1)
GROUND CABLE.....	HH.02.30 (1)
GROUND CABLE.....	HH.02.31 (1)
ELECTRICAL EQUIPMENT REAR.....	HH.02.33 (1)
LIGHTS REAR.....	HH.02.34 (1)
ELECTRICAL EQUIPMENT GRAIN TANK.....	HH.02.36 (1)
RELAY 10/20 A.....	HH.02.38 (1)
RELAY 10/20 A.....	HH.02.39 (1)
GRAIN OUTLET PIPE LIGHTING.....	HH.02.41 (1)
STRAW HOPPER INTERNAL LIGHTING.....	HH.02.43 (1)
ELECTRICAL LEAD.....	HH.02.44 (1)
ELECTRICAL SYSTEM FOR GRAIN LOSS CONTROL.....	HH.02.46 (1)
ELECTRICAL SIEVES ADJUSTMENT.....	HH.02.47 (1)
ELECTRICAL SYSTEM.....	HH.02.48 (1)
ELECTRIC STRAW CHOPPER ADJUSTMENT.....	HH.02.52 (1)
TRAILER SOCKET-OUTLET.....	HH.02.53 (1)
CUTTING PLATFORM WIRING.....	HH.02.54 (1)

ELECTRICAL CLIMATE CONTROL SYSTEM

Fig.	Code	QTY	Name
------	------	-----	------

Notes:

[6090 ->14500]

51	01178519	4	relay
52	01164650	4	base
103	16058810	1	electrical system
104	0.016.1399.0	1	support
105	06257542	2	rubber bushing

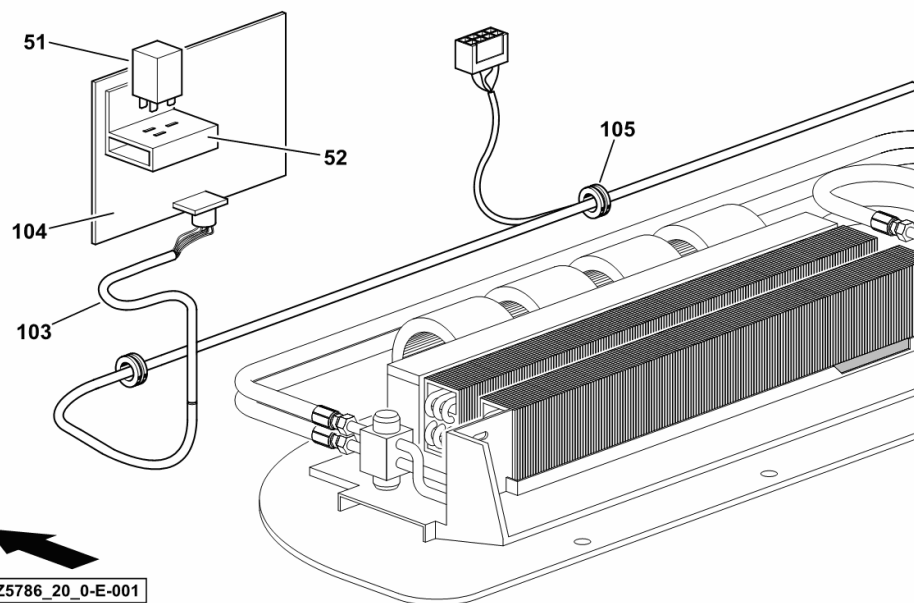

H9_Z5786_20_0-E-001

Section: HH - ELECTRICAL SYSTEM
ENGINE CONTROL UNIT BOX

Fig.	Code	QTY	Name
------	------	-----	------

Notes:
 [6090 ->14500]

1.1	16064209	1	box E3
1.2	01112345	4	screw m 8 x 30
1.3	16052320/20	1	plate
1.4	01103493	8	screw m 3.5 x 9.5
1.9	16052322	1	gasket
1.10	06214132	4	screw m 6 x 15, d921
1.11	01107158	4	washer 6.6, d125
1.12	01114357	4	nut m 6, d985
1.15	16064210	4	spacer
1.16	01112287	4	screw m 6 x 60, d933
1.17	01114357	4	nut m 6, d985
1.18	16064236	1	gasket
2	01104944	4	nut m 8, d985
45	16062295	0.25	band

H9_Z33H0_07_0-F-002

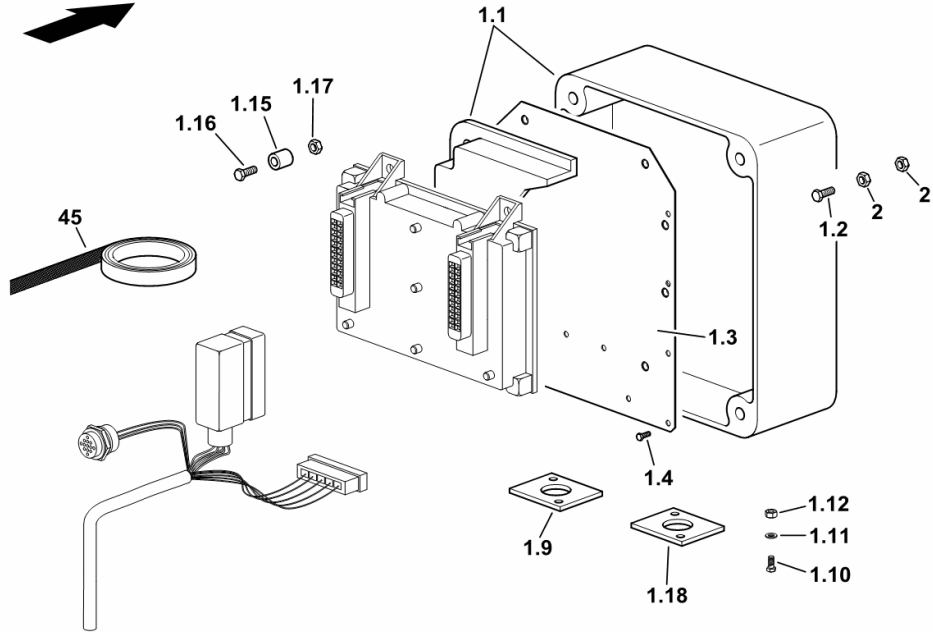

Section: HH - ELECTRICAL SYSTEM
ELECTRICAL EQUIPMENT REAR

Fig.	Code	QTY	Name
------	------	-----	------

Notes:

[6090 ->14500]

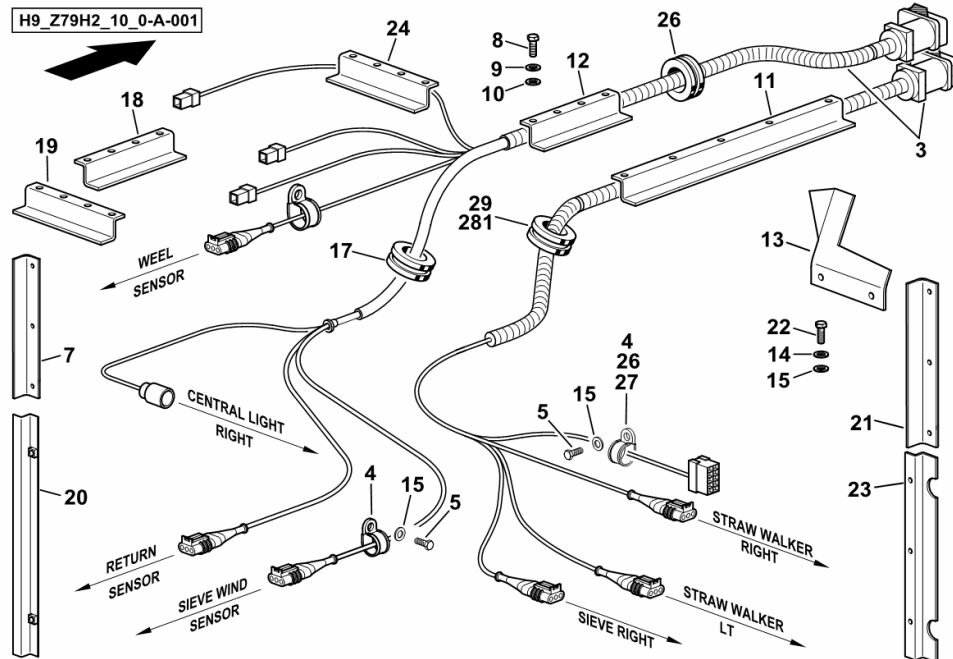

3	0.017.5019.4	1	electrical system
4	01179998	1	clamp 16
5	01112240	12	screw m 6 x 12
7	16020134	1	lamination L = mm 460 (14524 - 14525)
7	16020134/10	1	lamination L = mm 460 (-> 14523)
8	01112307	8	screw m 8 p.1.25 x 15, d933
9	01107163	8	washer 9, d126
10	01102799	8	washer 8, d128
11	16005160	1	lamination L = mm 1567 (14524 - 14525)
11	16005160/10	1	lamination L = mm 1567 (-> 14523)
12	06542070	1	lamination L = mm 968 (14524 - 14525)
12	06542070/10	1	lamination L = mm 968 (-> 14523)
13	16017114	1	lamination
14	06214189	6	washer 6.4
15	01102797	9	washer 6, d128
17	06262128	4	grommet Ø 21
18	16005181	1	lamination L = mm 930
19	16017115	1	lamination L = mm 160
20	16062511	1	lamination L = mm 265
21	16017094	1	lamination L = mm 500
22	01103316	4	screw m 6 p.1.0 x 16
23	16004875	1	lamination L = mm 410
24	16017100	1	lamination L = mm 315
26	2.6839.066.0/10	5	clamp 16
27	2.6839.051.0	5	clamp 20/20
29	06253950	2	grommet Ø 12.5 / Ø 15
281	16062712	2	grommet

ELECTRICAL SYSTEM

Fig.	Code	QTY	Name
------	------	-----	------

Notes:

BALANCE/AUTOCONTROL [6090 ->14500]

1.2	16040668	1	electrical system
1.3	04372302	1	fuse 15 A
1.4	01145036	2	relay 10/20 A
1.9	01172065	10	clamp 4.6 x 146
1.20	16046147	1	electrical system
1.21	0.016.1616.4	1	electrical system

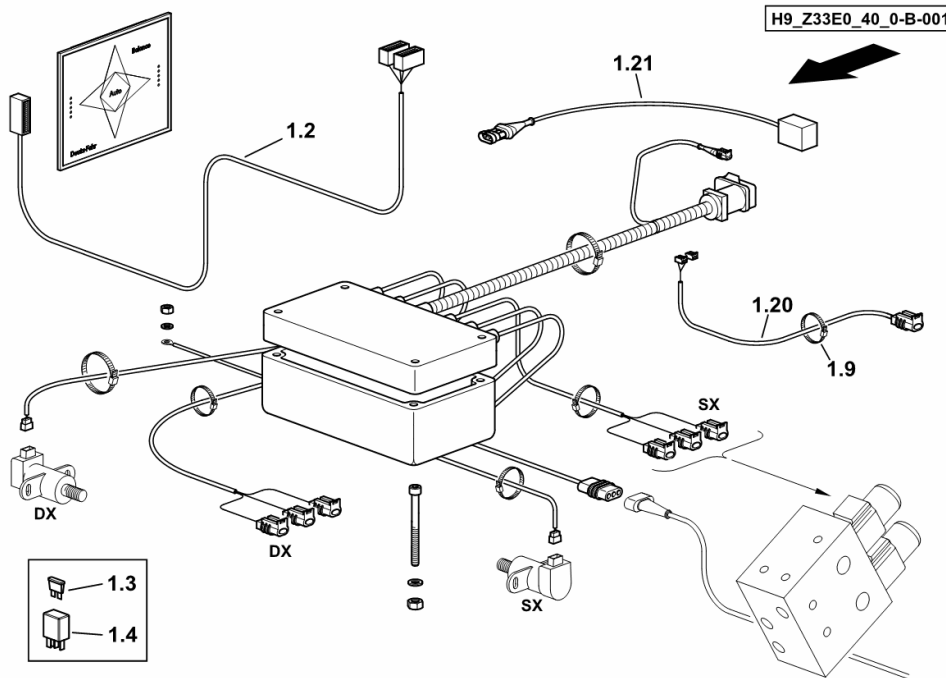

Section: HH - ELECTRICAL SYSTEM
BRAKING SYSTEM SENSOR

Fig.	Code	QTY	Name
------	------	-----	------

Notes:
[6090 ->14500]

4	02317786	1	switch
---	----------	---	--------

H9_Z33H0_03_0-C-001

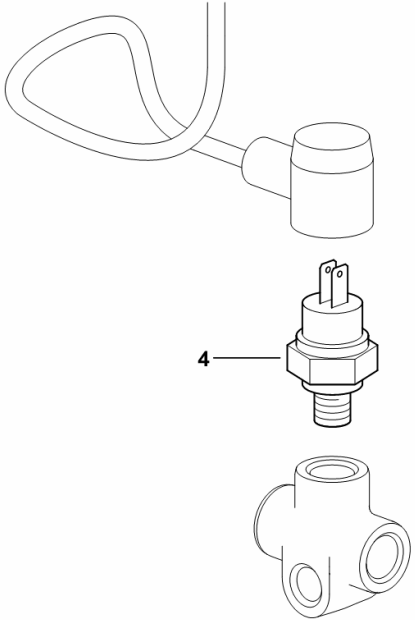

GRAIN TANK SENSOR

Fig.	Code	QTY	Name
------	------	-----	------

Notes:

[6090 ->14500]

24	01179999/60	2	clamp Ø 13
26	01112264	3	screw m 6 x 20, d933
38	01172065	12	clamp 4.6 x 146
48	01172065	2	clamp 4.6 x 146
59	16050180	1	sensor m 18 p.1
60	16057590	1	bracket
61	01112322	2	screw m 8 p.1.25 x 20
62	01104944	2	nut m 8, d985
63	01107163	2	washer 9, d126
64	01102799	2	washer 8, d128

H9_Z33H0_06_0-G-001

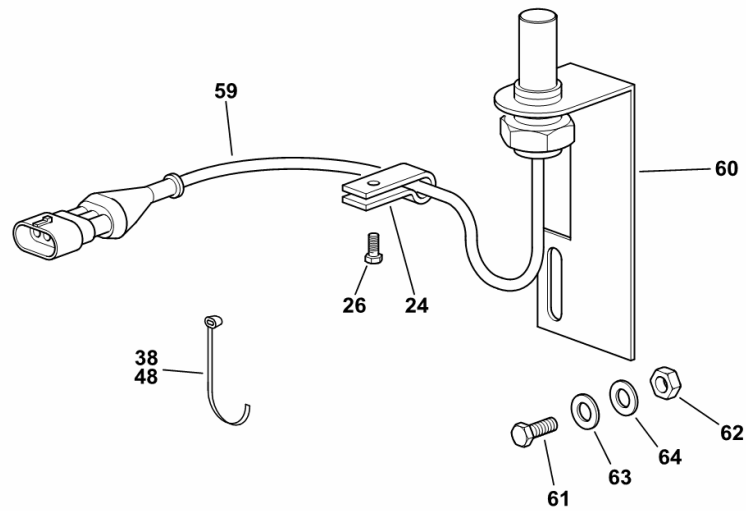

Section: HH - ELECTRICAL SYSTEM
OIL TEMPERATURE SENSOR

Fig.	Code	QTY	Name
------	------	-----	------

Notes:
[6090 ->14500]

1	2.7099.800.0	1	sensor
2	2.1560.010.0	1	gasket 14.2 x 20 x 1.5
3	01116656	1	pipe fitting m 30 p.2
4	2.3249.366.2	1	pipe fitting m 14 p.1.5
5	16033362	1	pipe fitting geo 22-l

H9_Z61D5_05_0-A-001

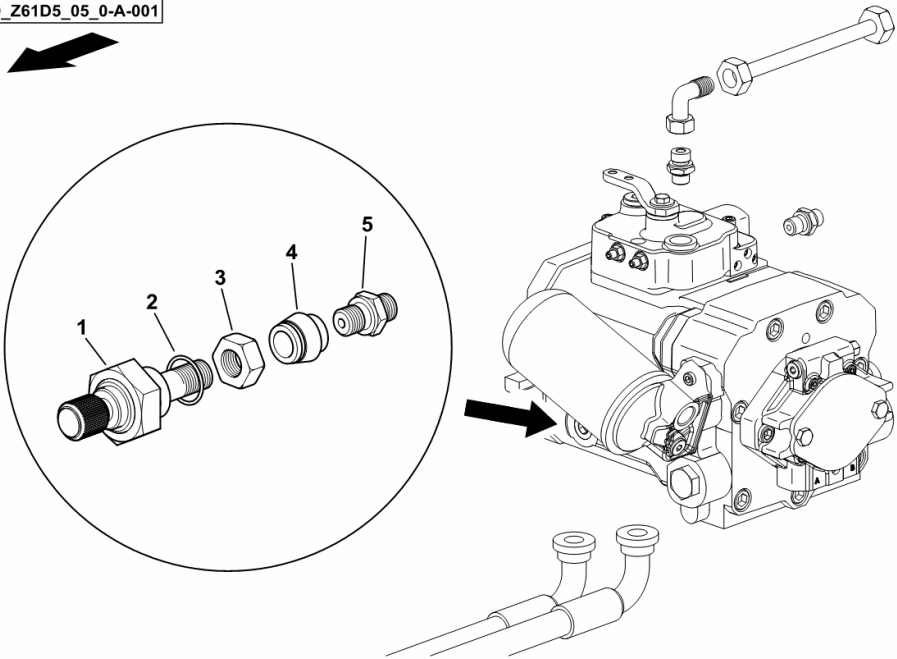

SENSOR - SPEED

Fig.	Code	QTY	Name
------	------	-----	------

Notes:
[6090 ->14500]

2	16050180	2	sensor m 18 p.1
3	16050240	1	magneto T 13

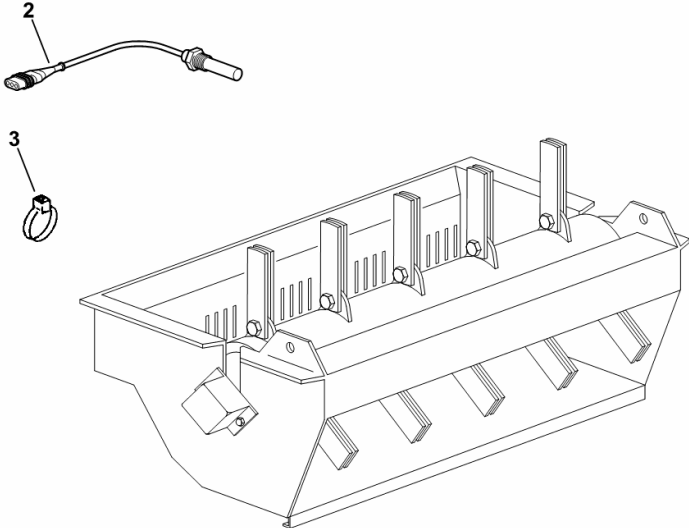

H9_Z57H3_20_0-B-001

CLICK HERE TO **DOWNLOAD** THE COMPLETE MANUAL

- Thank you very much for reading the preview of the manual.
- You can download the complete manual from: www.heydownloads.com by clicking the link below



- Please note: If there is no response to CLICKING the link, please download this PDF first and then click on it.

CLICK HERE TO **DOWNLOAD** THE COMPLETE MANUAL

SWITCHES

Fig.	Code	QTY	Name
------	------	-----	------

Notes:

[6090 ->14500]

1	2.7659.333.0	2	body
2	2.7659.331.0	1	switch
			- FLASHING LIGHT
3	2.7659.307.0	1	switch
			SCREEN WIPER
4	2.7659.321.0	1	switch
			- WINDSCREEN WASHER LIQUID
5	0.012.5940.4	1	switch
			- RUNNING LIGHTS
6	2.7659.332.0	1	switch
			- "TOP" LIGHTS
7	2.7659.323.0	1	switch
			WORKING SPOTLIGHT
11	16056566	1	casing

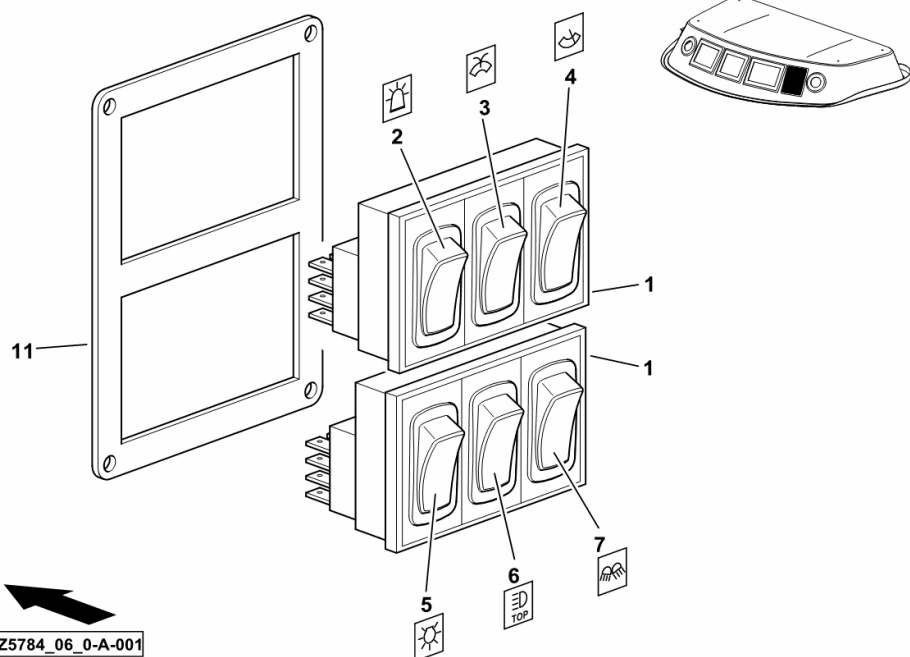

H9_Z5784_06_0-A-001

Section: HH - ELECTRICAL SYSTEM
WORKLIGHTS SWITCH

Fig.	Code	QTY	Name
------	------	-----	------

Notes:

[6090 ->14500]

1	2.7659.339.0	1	switch WORKING SPOTLIGHT
---	--------------	---	-----------------------------

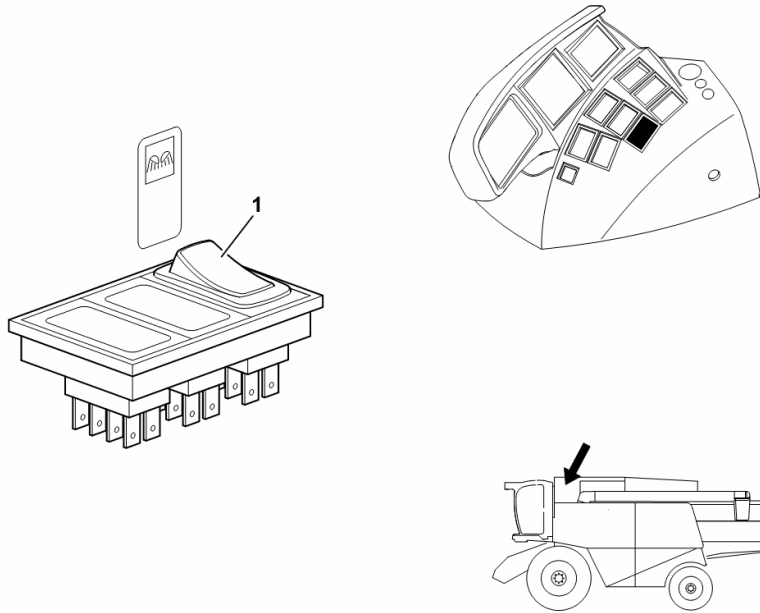

H9_Z75H2_70_0-B-001

ELECTRIC MOTOR

Fig.	Code	QTY	Name
------	------	-----	------

Notes:

[6090 ->14500]

1.1.1	16027276	1	electric motor
1.1.2	01111497	2	screw m 12 x 55
1.1.3	01107110	2	washer 13.5
1.1.4	06209778	2	nut m 12
1.1.5	16052581	1	support
1.1.55	16055184	1	bracket
1.1.56	01111488	1	screw m 12 x 50
1.1.57	01107110	2	washer 13.5
1.1.58	06209778	1	nut m 12

H9_16056_30_8-C-001

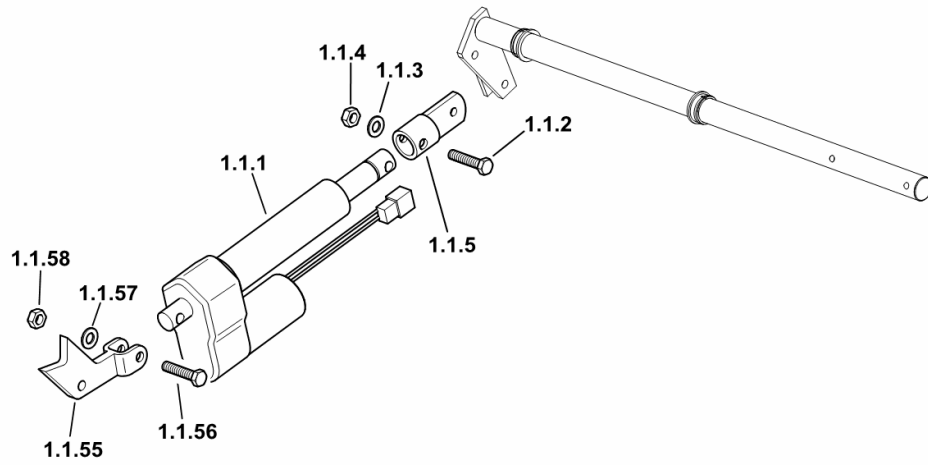



Section: HH - ELECTRICAL SYSTEM
FRONT LIGHTS

Fig.	Code	QTY	Name
------	------	-----	------

Notes:
- EXPORT GB [6090 ->14500]

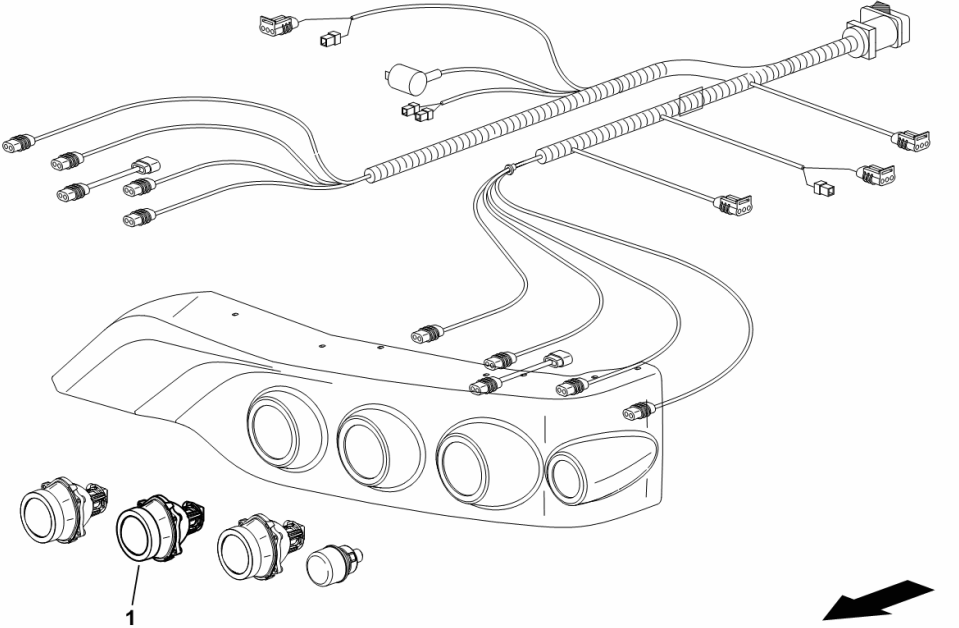
1	2.8039.008.0	2	headlight - LOW BEAM HEADLIGHTS ☞ 2.8039.008.0
---	--------------	---	--



H9_Z75H2_35_0-A-001

WORKING SPOTLIGHT

Fig.	Code	QTY	Name
------	------	-----	------

Notes:

[6090 ->14500]

2	16046038	2	headlight ☞ 16046038
3	06262128	4	grommet Ø 21
6	01172065	5	clamp 4.6 x 146

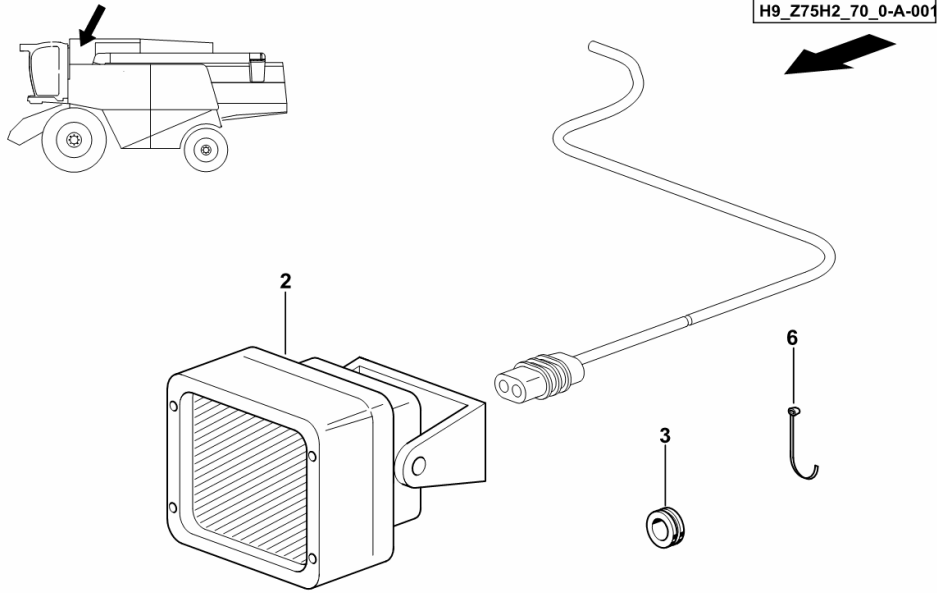

STRAW HOPPER INTERNAL LIGHTING

Fig.	Code	QTY	Name
------	------	-----	------

Notes:

[6090 ->14500]

27.4	16046038	1	headlight ☞ 16046038
------	----------	---	-------------------------

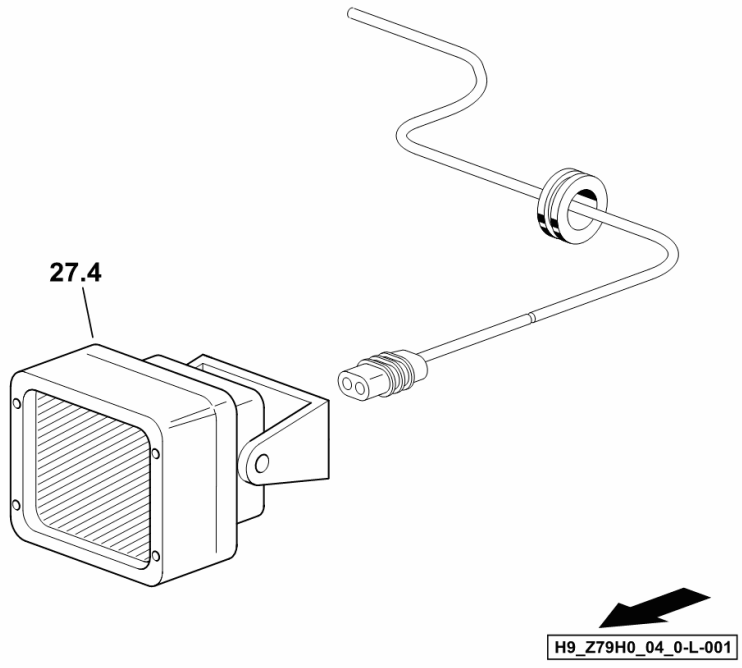

Section: HH - ELECTRICAL SYSTEM
SUPPORTS

Fig.	Code	QTY	Name
------	------	-----	------

Notes:
 - EXPORT F [6090 ->14500]

1.33	16056764	4	tube
1.34	16064002	1	plate
1.35	16056765	2	plate

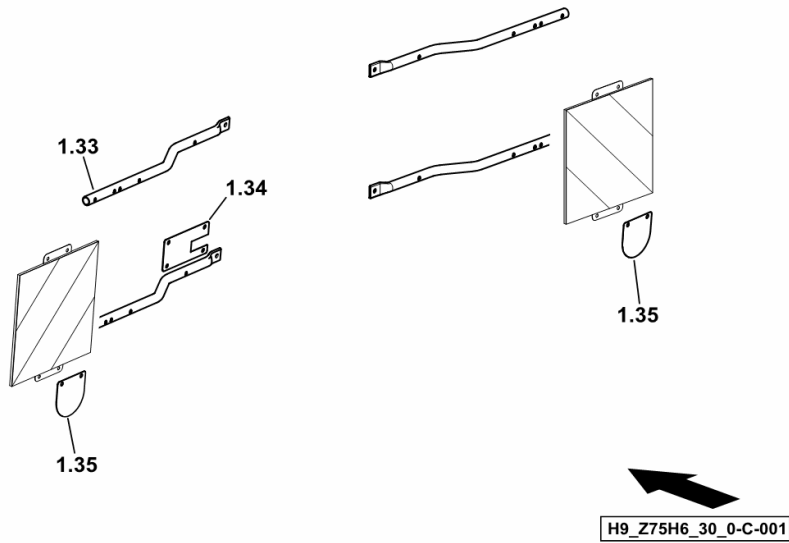

LIGHTING

Fig.	Code	QTY	Name
1.33.6	01112211	2	screw m5x18 d933
1.33.7	01112803	4	nut m 5, d934
1.33.8	06209765	2	nut m 5, d985
1.33.9	06311779	1	cloth/tarpaulin?
1.33.10	01112240	2	screw m 6 x 12
1.33.11	01114357	2	nut m 6, d985
1.33.13	06214189	1	washer 6.4
1.33.14	06213721	4	sleeve
1.33.15	06213974	1	connection
1.34.1	06504581	1	arm dx/rh/re
1.34.2	06542560	1	cable harness
1.34.3	06521640	1	side lamp
1.34.4	01102550	1	lamp r121w d72601
1.34.5	01121409	1	lamp g/10w d72601
1.34.6	01112211	2	screw m5x18 d933
1.34.7	01112803	4	nut m 5, d934
1.34.8	06209765	2	nut m 5, d985
1.34.9	06311779	1	cloth/tarpaulin?
1.34.10	01112240	2	screw m 6 x 12
1.34.11	01114357	2	nut m 6, d985
1.34.13	06214189	1	washer 6.4
1.34.14	06213721	4	sleeve
1.34.15	06213974	1	connection
1.35	01112824	4	nut m 8, d934
1.36	01112326	4	screw m 8 x 22
1.37	16005957	2	shield
1.38	01102534	4	screw m 5x40 d931
1.39	01112803	8	nut m 5, d934
990	01102769	4	plug
991	06520277	2	link
992	06257558	2	rubber ring 14x18x3
993	06241450	6	interlock
994	16011203	2	link
995	01111336	1	screw m 10 x 75
996	06209768	1	nut m 10, d985
997	16011191	1	plate
998	01112287	2	screw m 6 x 60, d933
999	01114357	2	nut m 6, d985

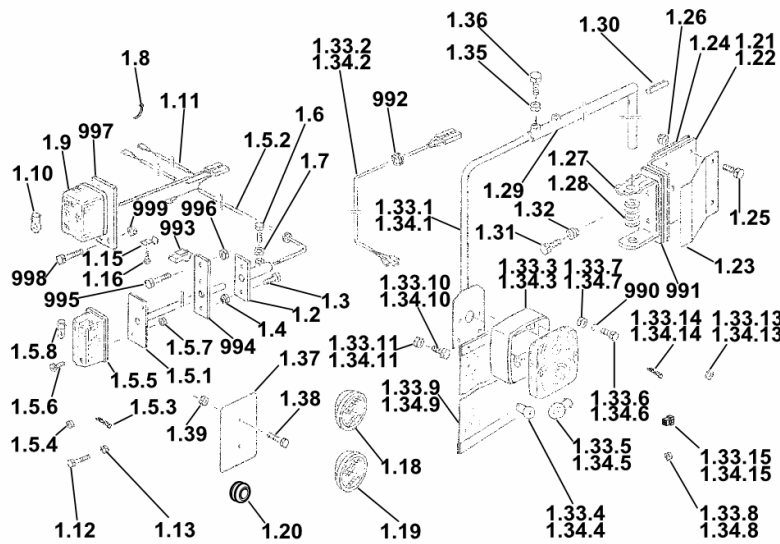

H9_97531_00_0-A-002

HEADLAMP COMPONENTS

Fig.	Code	QTY	Name
1	2.8039.005.0	1	headlight
2	0.900.1539.2	1	lamp
3	0.000.0000.1	1	not serviceable

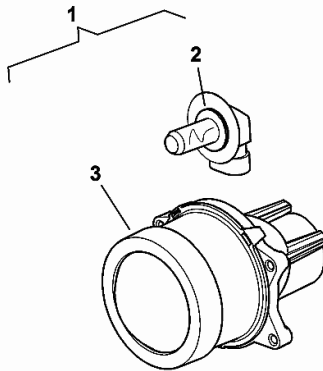

2_8039_005_0

FASTENINGS.....	B0.04.1020
ROCKER ARM BRACKET.....	B0.04.1034
ROCKER ARM BRACKET.....	B0.04.1047
ROCKER ARM BRACKET.....	B0.04.1051
ROCKER ARM BRACKET.....	B0.04.1055
CAMSHAFT.....	B0.04.1068
CAMSHAFT.....	B0.04.1073
CAMSHAFT.....	B0.04.1075
CAMSHAFT.....	B0.04.1084
ROCKER ARM BRACKET.....	B0.04.1093
ROCKER ARM BRACKET.....	B0.04.1095
ROCKER ARM BRACKET.....	B0.04.1096
SEALING.....	B0.04.1099
SEALING.....	B0.04.1100
GEARCASE.....	B0.04.1112
GEARCASE.....	B0.04.1119
CYLINDER HEAD	
FASTENINGS.....	B0.05.1009
ENGINE MOUNTING.....	B0.05.1018
ENGINE MOUNTING.....	B0.05.1019
CYLINDER HEAD.....	B0.05.1040
VALVE MECHAN.COVER.....	B0.05.1056
FILLER CAP.....	B0.05.1057
LUBRICATION	
FASTENINGS.....	B0.06.1011
FASTENINGS.....	B0.06.1012
FASTENINGS.....	B0.06.1014
SEALING.....	B0.06.1018
OIL SUCTION PIPE.....	B0.06.1039
OIL SUCTION PIPE.....	B0.06.1044
OIL PAN.....	B0.06.1046
CLOSING COMPONENTS.....	B0.06.1084
CLOSING COMPONENTS.....	B0.06.1095
CLOSING COMPONENTS.....	B0.06.1096
CLOSING COMPONENTS.....	B0.06.1097
HYDRAULIC PUMP DRIVE.....	B0.06.1109
OIL COOLER BOX.....	B0.06.1132
ENGINE COOLING SYSTEM PIPES.....	B0.06.1157
FUEL INJECTION SYSTEM	
FASTENINGS.....	B0.07.1016
FASTENINGS.....	B0.07.1018
ADD-ON PARTS ENGINE.....	B0.07.1019
FUEL FEED PUMP.....	B0.07.1050
FUEL FEED PUMP.....	B0.07.1051

Section: B0 - ENGINE
CRANKCASE BREATHER

Fig.	Code	QTY	Name
1	04905228	1	tube WITH POS.... (2,3,11)
2	01175559	3	hose clip H 3223 -C8X15-ST/MVQ-1-70
3	01118673	3	'o' ring DIN 7603 -A12X15,5-CU
5	04905110	1	breather WITH POS.... 9
6	01181432	2	screw EN 1662 -F-M8X30-10.9-ZNAL-A
7	01180071	2	hose clip H 3461 -F-14,0/8
8	01174783	1	rubber tube H 3430 -A8X14X70
9	04298547	1	rubber plug
10	01181442	1	screw EN 1662 -F-M6X12-10.9-ZNAL-A
11	01119241	1	pipe union m 12 p.1.5 DIN 7643 -8
19	04905469	1	pipe fitting WITH POS.... (20,21)
20	01118737	1	'o' ring 22 x 27 DIN 7603 -A22X27-CU
21	04904834	1	power control

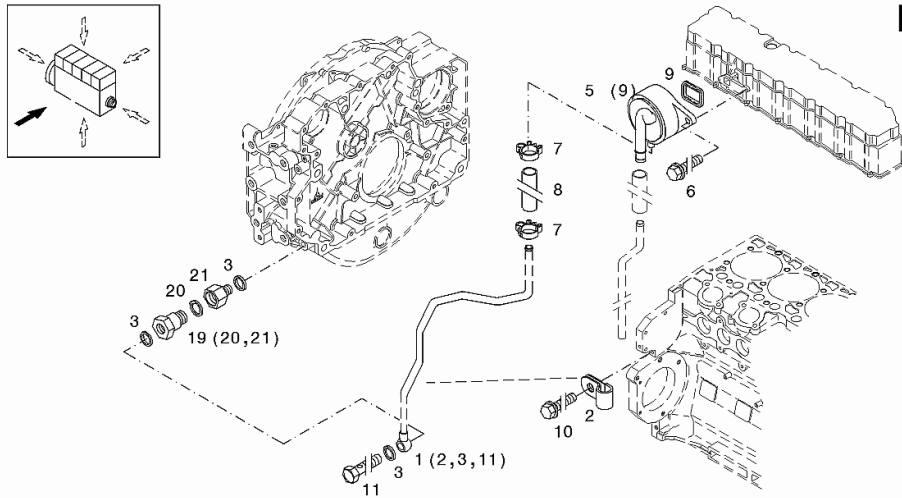

Section: B0 - ENGINE
CLOSING COMPONENTS

Fig.	Code	QTY	Name
------	------	-----	------

Engine Serial Numbers:
10973446 10976219

1	01165835	1	stop H 711 -B35
189	01319910	1	guard

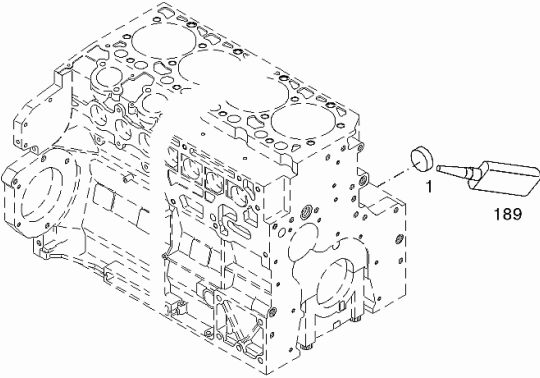
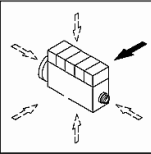

000 ©

Section: B0 - ENGINE
CRANKSHAFT

Fig.	Code	QTY	Name
------	------	-----	------

Engine Serial Numbers:
10973446 10976219

1	04908850	1	crank shaft WITH POS.... (2-5)
2	04902558	1	gear
3	04904797	1	gear
4	04299420	1	ring
5	01183226	10	grain H 2358 -AM12X1,25X18

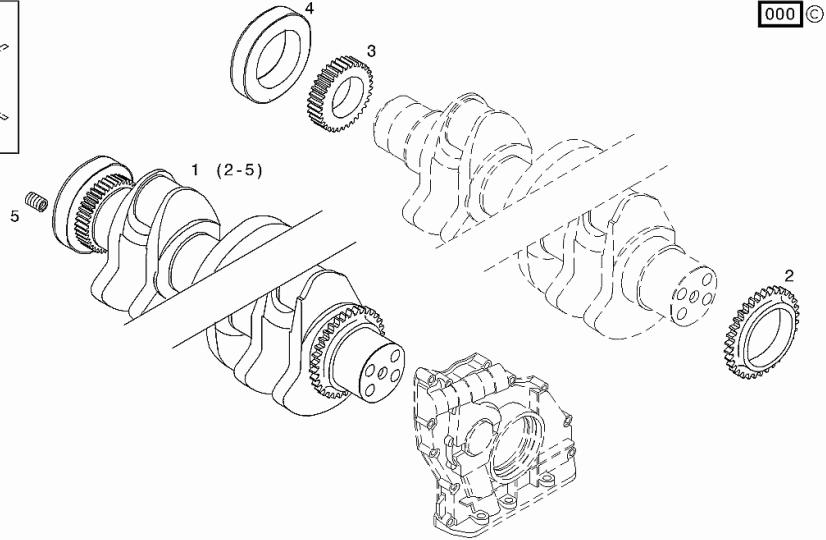
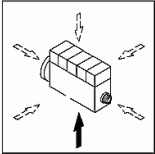

Section: B0 - ENGINE
ROCKER ARM BRACKET

Fig.	Code	QTY	Name
1	04902784	1	support
2	04902780	5	support
3	04902786	1	support
4	04906093	6	rocker WITH POS.... 7,8
5	04906097	6	rocker WITH POS.... 7,8
6	01107731	2	circlip DIN 471 -21X1,2
7	04903343	12	register
8	02109637	12	nut
9	01148415	14	screw
10	04903105	1	rod WITH POS.... 11
11	01180113	2	plug DIN 443 -14
12	04901080	6	spring
13	01167267	2	sleeve H 2341 -B11X20
185	01016123	1	small plate H 0699 -DEUTZDW71-50ML

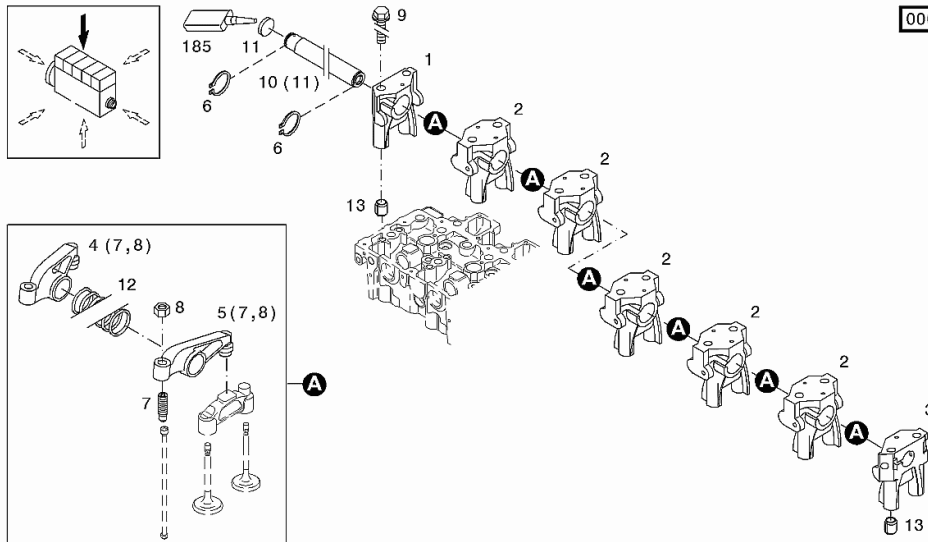

Section: B0 - ENGINE
ROCKER ARM BRACKET

Fig.	Code	QTY	Name
------	------	-----	------

Engine Serial Numbers:
 10973446 10976219

1	04909191	12	spring rockerarm
2	04902837	12	rod
3	04903344	12	lever

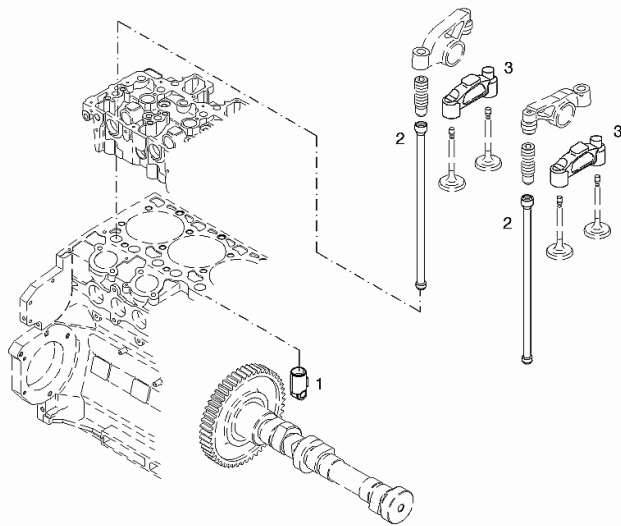
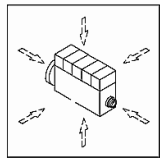

000 ©

FILLER CAP

Fig.	Code	QTY	Name
------	------	-----	------

Engine Serial Numbers:

10773229 10778643 10781728 10973446 10976219

1	04902412	1	plug
---	----------	---	------

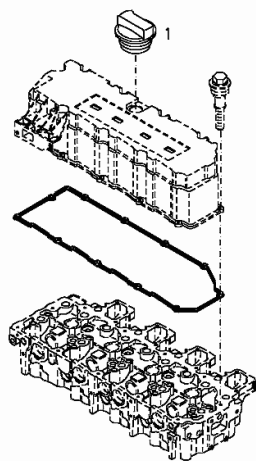
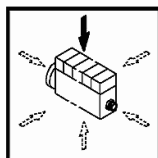

000 ©

Section: B0 - ENGINE
CLOSING COMPONENTS

Fig.	Code	QTY	Name
------	------	-----	------

Engine Serial Numbers:

10773229 10778643 10781728 10973446 10976219

1	01148569	1	plug DIN 908 -M10X14-ST-ZNAL-A*
2	01148862	1	'o' ring DIN 7603 -D10X15-CU-VERZINNT
3	01148158	1	plug DIN 908 -M26X1,5-ST-A4C
4	01148892	1	'o' ring DIN 7603 -D26X31-CU-VERZINNT*

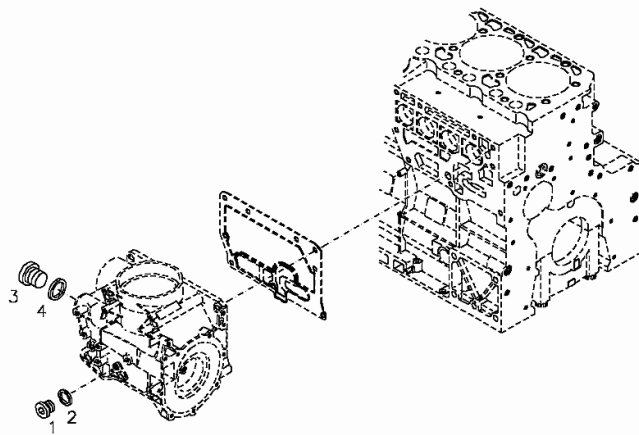
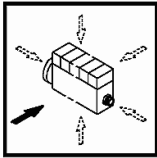

FUEL FILTER

Fig.	Code	QTY	Name
------	------	-----	------

Engine Serial Numbers:

10773229 10778643 10781728 10973446 10976219

1	04902766	1	filter kpl. WITH POS.... (2)
2	02931530	1	fuel filter element WITH POS.... (4)
3	01181441	3	screw EN 1662 -F-M8X65-10.9-ZNAL-A
4	04901969	1	'o' ring

000 ©

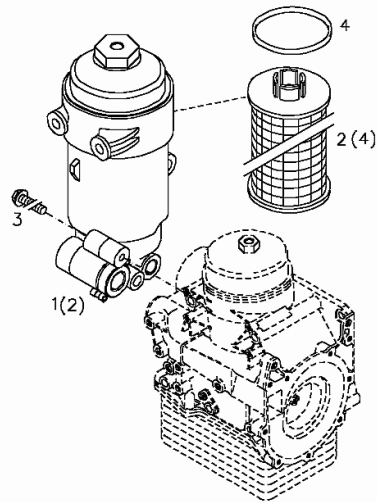
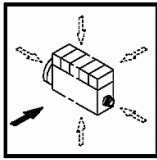

Section: B0 - ENGINE
FUEL SUPPLY PUMP

Fig.	Code	QTY	Name
------	------	-----	------

Engine Serial Numbers:
10973446 10976219

1	04907180	1	feed pump WITH POS.... (2)
2	01181918	1	ring H 2927 -55X2,5-FPM-1-70

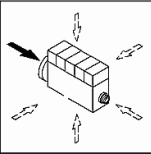

000 ©

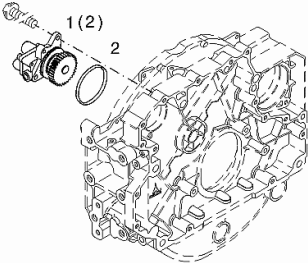

Section: B0 - ENGINE
THERMOSTAT

Fig.	Code	QTY	Name
------	------	-----	------

Engine Serial Numbers:

10773229 10778643 10781728 10973446 10976219

1	04906537	1	gasket
2	04904563	1	chassis
3	04908226	1	thermostat
4	04050225	1	'o' ring
5	04903098	1	gasket
9	01148892	2	'o' ring
			DIN 7603 -D26X31-CU-VERZINNT*
10	04900146	1	tongue
11	04906367	1	manifold
12	01181438	2	screw
			EN 1662 -F-M8X55-10.9-ZNAL-A
13	01181458	4	screw
			EN 1662 -F-M8X60-10.9-ZNAL-A
14	04213839	1	tempe guage
15	01180054	1	sensor
			H 3452 -E10/M16X1,5
18	04906985	1	sleeve
19	01136993	2	screw m 12 x 70
			DIN 933 -M12X70-10.9-A4C
20	01148838	1	'o' ring
			DIN 7603 -D16X22-CU-VERZINNT

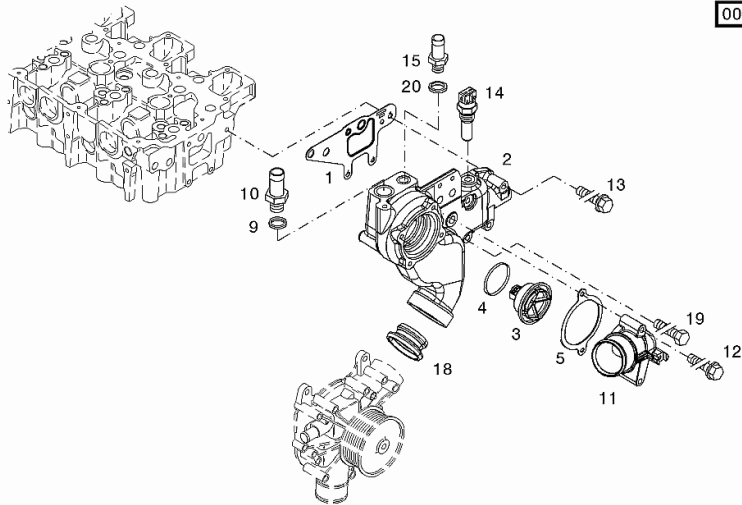
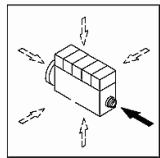

Section: B0 - ENGINE
RADIATOR

Fig.	Code	QTY	Name
38	01103274	2	nut DIN 936 -M10-17H-A4C
39	04258703	1	flange
40	01138774	2	nut m 8 ISO 4032 -M8-24CRMO5V
41	04903239	1	gasket
47	01148654	4	screw EN 1661 -M6-8-ZNAL-A
49	04213838	1	sensor
50	01148201	1	screw ISO 4017 -M6X16-8.8-ZNAL-A
51	04500342	2	washer
242	01016105	1	sealing compound

000 ©

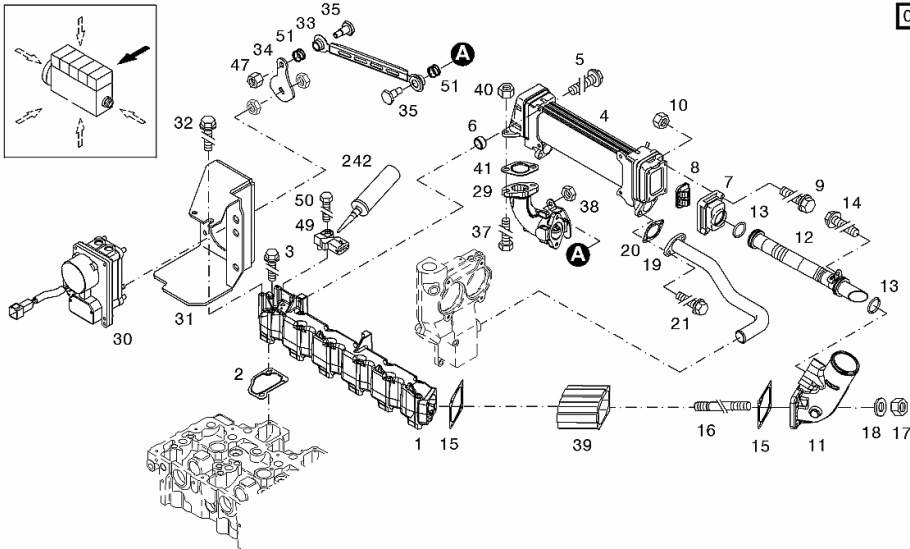

FASTENINGS

Fig.	Code	QTY	Name
------	------	-----	------

Engine Serial Numbers:

10773229 10778643 10781728 10973446 10976219

1	01148623	3	screw 60 Nm EN 1662 -F-M10X38-10.9-ZNAL-A
---	----------	---	---

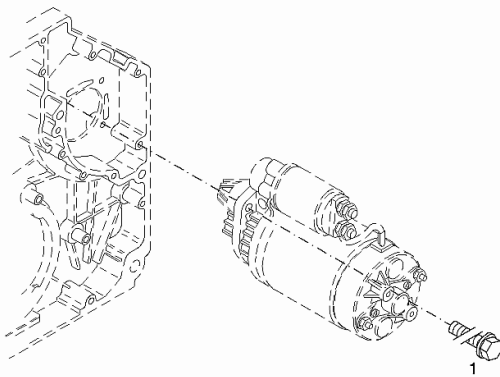
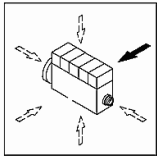

003 ©

ACCESSORIES

Fig.	Code	QTY	Name
------	------	-----	------

Engine Serial Numbers:

10773229 10778643 10781728 10973446 10976219

1	04213842	1	pipe fitting
---	----------	---	--------------

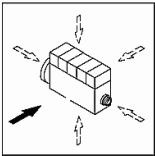

003 ©

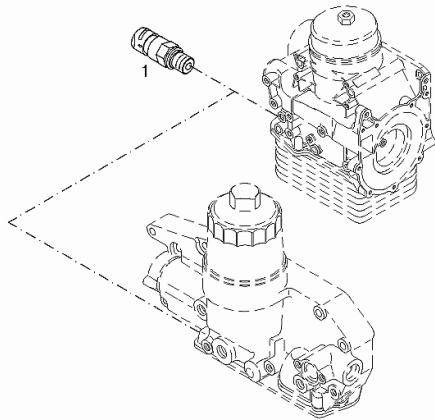

6090 ->14500

C0 - ENGINE ACCESSORIES

RADIATORS - FANS

COOLING SYSTEM.....	C0.01.0 (1)
COOLING SYSTEM.....	C0.01.0 (2)
BELT STRETCHER.....	C0.01.3 (1)
ENGINE COOLING SYSTEM PIPES.....	C0.01.6 (1)
ENGINE COOLING SYSTEM PIPES.....	C0.01.9 (1)
ROTARY FILTER BASKET.....	C0.01.10 (1)
BELT AND TENSIONER.....	C0.01.11 (1)
ENGINE AIR SUCTION FAN.....	C0.01.12 (1)
ENGINE AIR SUCTION FAN.....	C0.01.13 (1)
COOLANT RESERVOIR.....	C0.01.14 (1)
FUEL COOLER.....	C0.01.16 (1)
COOLING.....	16062971.A
COOLANT RESERVOIR.....	16062972.A

INTERCOOLER - AIR CLEANER

ENGINE'S AIR FILTER.....	C0.02.2 (1)
AIR FILTER.....	16049833.A

FUEL SYSTEM

FUEL TANK 555 LT.....	C0.03.0 (1)
FUEL TANK SUPPORTS.....	C0.03.2 (1)
FUEL PRELIMINARY FILTER.....	C0.03.4 (1)
FUEL TANK.....	0.016.6983.4.A
PRE-FILTER - COMPONENTS.....	2.4319.300.0/10.A

EXHAUST SILENCER

EXHAUST PIPE.....	C0.06.1 (2)
-------------------	-------------

AIR COMPRESSOR

COMPRESSED-AIR UNIT AIR VESSEL 6 SW.....	C0.07.0 (1)
AIR COMPRESSOR 6 SW.....	C0.07.1 (1)
COMPRESSOR-PARTS.....	04414768.A
PRESSURE REGULATOR.....	04434820.A

ENGINE POWER TAKE-OFF

ENGINE PTO.....	C0.10.2 (1)
ENGINE PTO.....	C0.10.6 (1)

ENGINE MOUNTINGS

ENGINE MOUNTINGS.....	C0.11.1 (1)
ENGINE MOUNTINGS.....	C0.11.3 (1)

COOLANT RESERVOIR

Fig.	Code	QTY	Name
------	------	-----	------

Notes:

[6090 ->14500]

1	16062972	1	container kg. 9.5 ☞ 16062972
2	01173965	12	clamp 10-16/9 h3461
3	06216402	1	clamp 15,9 ne
3	2.6839.066.0/10	1	clamp 16
4	01104944	4	nut m 8, d985
6	01112326	1	screw m 8 x 22
7	06513009	2	square
8	2.0114.209.2	4	screw m 8 x 25
9	2.1474.009.2	4	spring washer 8
10	2.1011.105.2	4	nut m 8 p.1.25
11	06214192	4	washer 8.4
12	16055277	1	flexible hose L = MM 850, Ø8
13	16055278	1	flexible hose L = MM 2200, Ø8
14	16062974	1	flexible hose L = MM 1700, Ø28
15	01173968	2	clamp Ø 25/40
16	2.3249.394.2	1	pipe fitting T
17	0.017.6469.0	1	flexible hose L = MM 600, Ø8
18	0.017.6470.0	1	flexible hose L = MM 260, Ø8

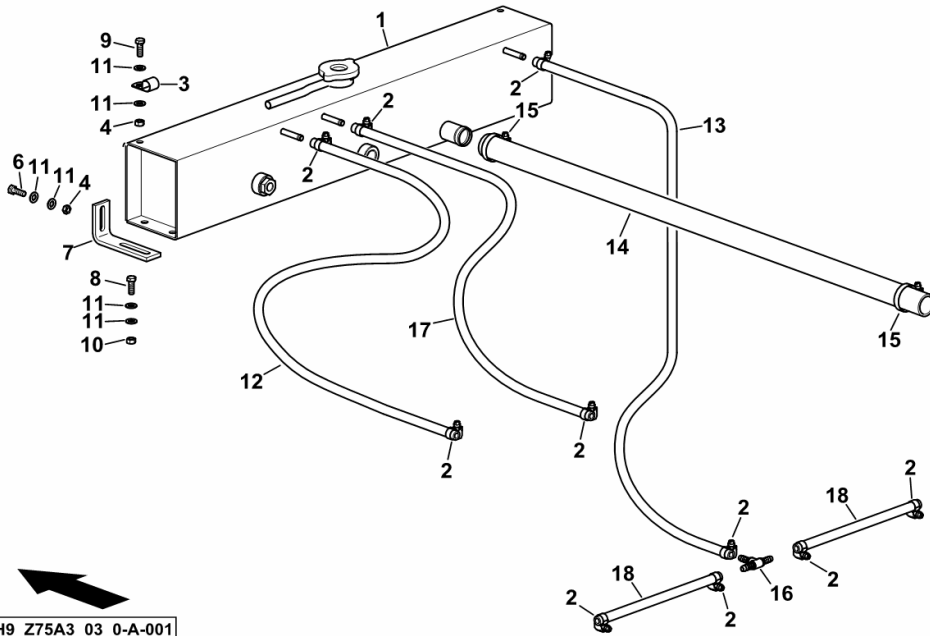

H9_Z75A3_03_0-A-001

PRE-FILTER - COMPONENTS

Fig.	Code	QTY	Name
1	2.4319.300.0/10	1	precleaner
2	0.900.0863.8	1	crown wheel
3	0.000.0000.1	1	not serviceable
4	0.900.0863.9	1	rubber ring
5	0.900.0789.8	1	ring
6	0.900.0864.3	1	screw
7	0.000.0000.1	1	not serviceable
8	0.900.0864.0	1	dust guard
9	0.900.0511.9	1	fuel filter element
10	0.900.0864.1	1	closure
11	0.900.0942.1	1	blokage warning ind.

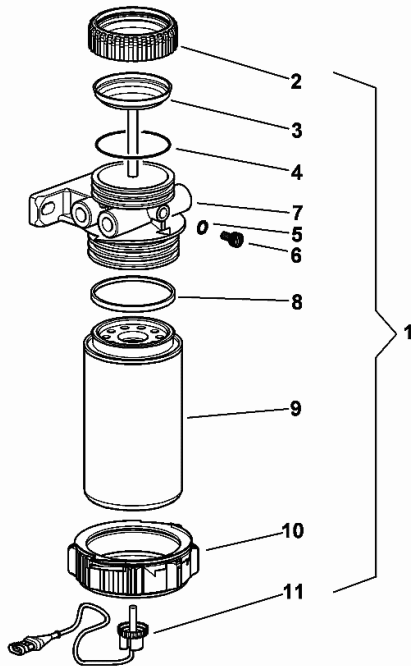

2_4319_300_0_10

ENGINE MOUNTINGS

Fig.	Code	QTY	Name
------	------	-----	------

Notes:

[6090 ->14500]

1	16062741/10	1	support
2	16062742/10	1	support
3	01112538	4	screw m 12 x 35, d933
4	01102801	4	washer 12
5	16062740	1	support
6	16062739	1	support
7	01112679	4	screw m 16 x 35
8	06209704	6	screw m 16 p.1x35

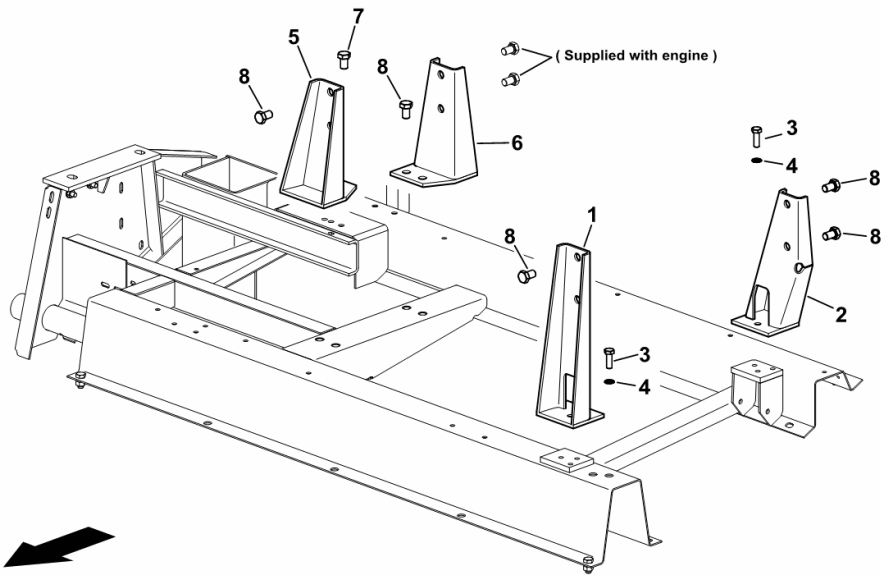

H9_Z33A0_21_0-A-001

Section: HE - FEED ELEVATOR
LOADING ROLLER

Fig.	Code	QTY	Name
------	------	-----	------

Notes:
 [6090 ->14500]

1.6	16031117	4	small plate mm 55
1.7	01112502	8	screw m 12 x 20
1.8	01102801	8	washer 12
1.9	16062683	2	small plate m 35
1.29	16062577	2	rod m 16
1.30	01112886	4	nut m 16
1.31	16025727	2	smau pin m 16
1.32	01127856	2	nut m 16, d985
1.89	16029056	1	support sx/lh/li
1.90	16029054	1	support dx/rh/re
1.91	01118030	1	dowel 8.0 x 7.0 x 22
1.171.1	16057682/10	1	roller L = mm 1447
1.171.2	01145564	2	bearing GYE40 - KRR - B
1.171.3	16063144	1	shaft L = mm 1479
1.171.4	16057681	2	bearing housing
1.171.5	01102800	8	washer 10.2
1.171.6	01110682	8	screw m 10 p.1.5 x 45

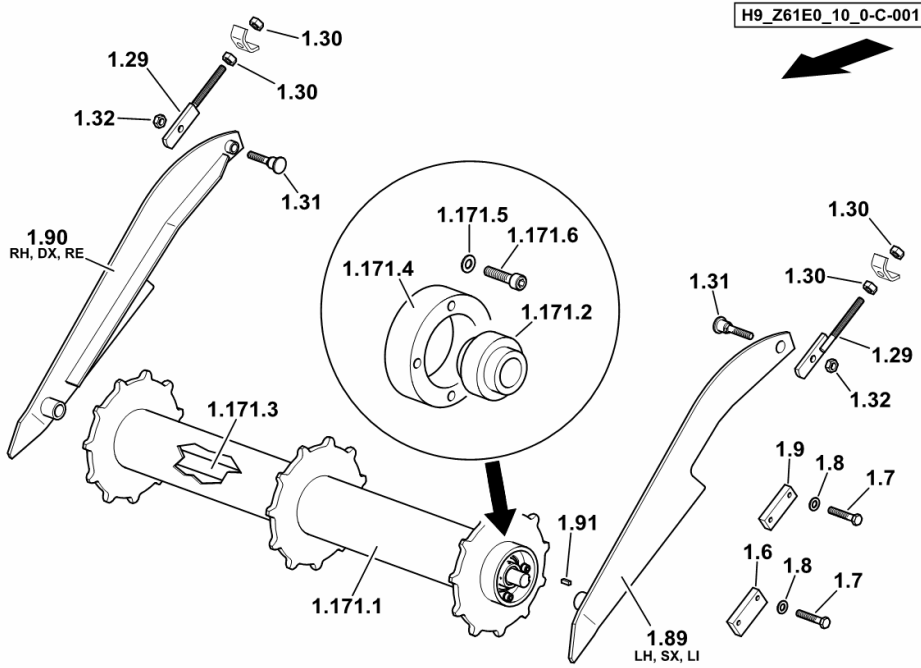

FIXED FRAME

Fig.	Code	QTY	Name
------	------	-----	------

Notes:

[6090 ->14500]

1	16052133	1	chassis frame
2	16054311	2	stay m 16
3	2.1011.109.2	4	nut m 16 p.2
4	06214216	2	washer 17
5	2.1690.516.2	2	split pin 5x50
6	16033143/10	2	smau pin
7	2.1310.006.2	2	flat washer 10.5
8	2.1474.010.2	2	washer 10
9	2.0114.311.2	2	screw m 10 p.1.25 x 30
10	06568995	1	rubber
11	06510669	2	pin
12	2.0114.011.2	2	screw m 6 p,1x30
13	2.1120.003.2	2	nut m 6
14	2.1310.007.2	2	flat washer 13.5
15	06215344	2	spring
16	2.1630.611.0	2	roll pin 6 x 24
17	06214218	6	washer 17x50x6
18	2.1474.013.2	6	washer 16
19	2.0114.613.2	6	screw m 16 x 35
20	16022556	5.9	anti-slip coating (mt. ...)

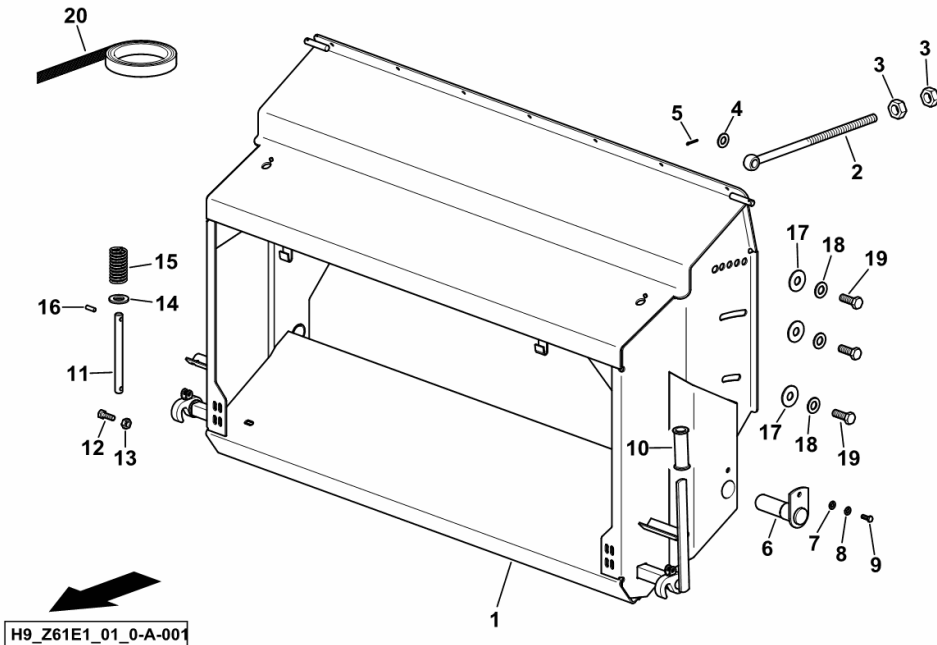

H9_Z61E1_01_0-A-001

Section: HE - FEED ELEVATOR
BELT ENGAGEMENT CONTROL

Fig.	Code	QTY	Name
------	------	-----	------

Notes:

[6090 ->14500]

1.1.6	06214197	2	washer 10.5
1.1.7	06209768	1	nut m 10, d985
1.1.8	01111298	1	screw m 10 p.1.5 x 45
1.1.9	16052582	1	shaft
1.1.10	06260833	2	bushing 30,3 x 35 x 15
1.1.11	06215810	2	ring 30 x 44
1.1.12	16062311	1	lever
1.1.13	01115476	1	pin 8 x 45, d1481
1.1.14	01157336	1	pin 5 x 45
1.1.15	01107165	3	washer 10.5
1.1.16	01132625	1	split pin 3.2 x 20
1.1.17	06210009	1	smau pin 10 x 28 x 24

H9_16056_30_8-E-001

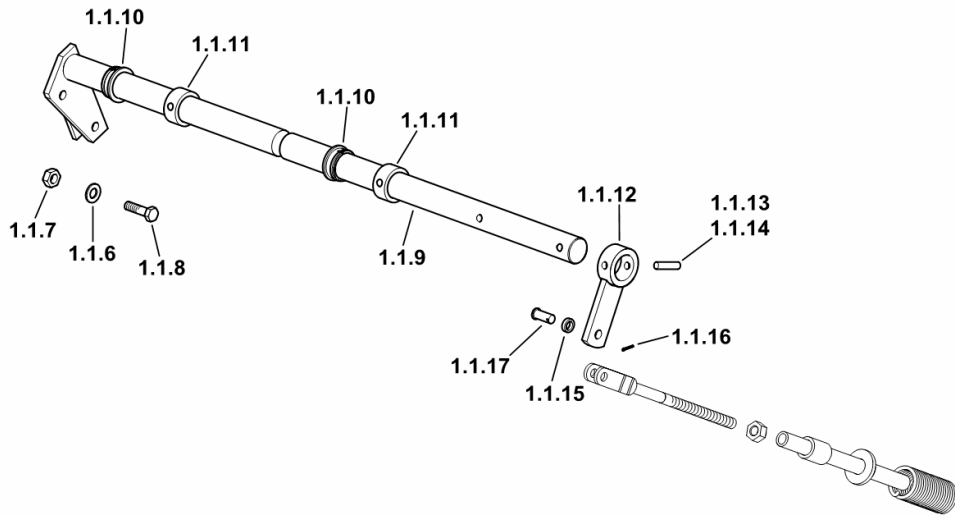

TOOTHED THRESHING DRUM

Fig.	Code	QTY	Name
------	------	-----	------

Notes:

- EXPORT GB [6090 ->14500]

1	06237940	1	guard
2	01138802	3	screw m 10 x 35
3	01102659	3	nut m 10, d934
4	01107165	6	washer 10.5

H9_Z75H6_90_0-A-00

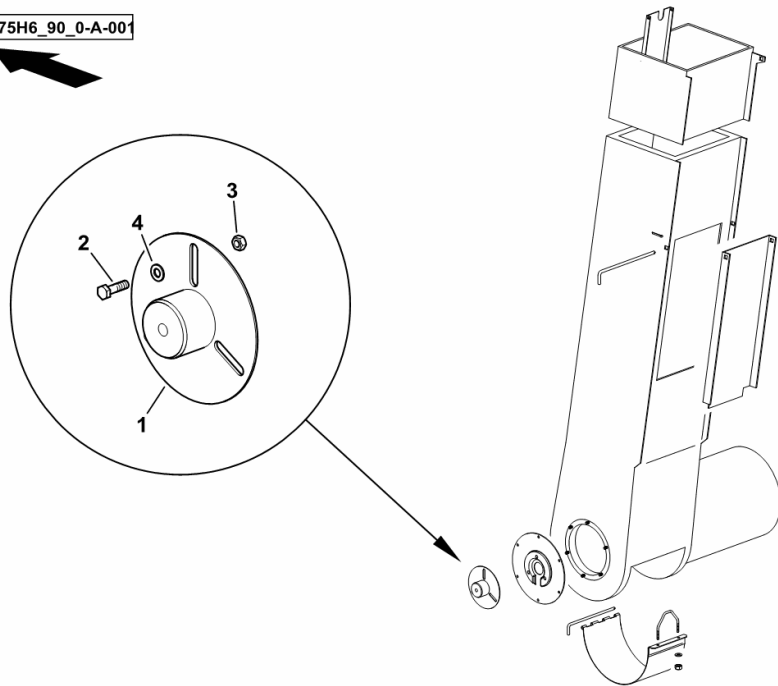

Section: HM - GRAIN TANK / ELEVATOR
ELEVATOR HEAD FEED SCREW

Fig.	Code	QTY	Name
------	------	-----	------

Notes:
 [6090 ->14500]

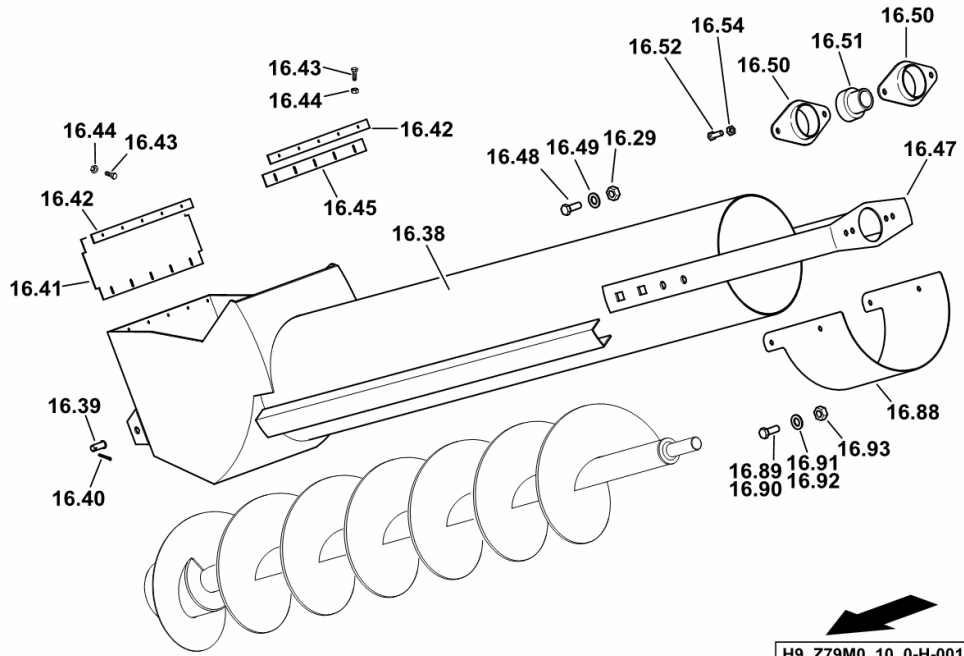

16.29	06209768	8	nut m 10, d985
16.38	16063441	1	tube L = mm 1261
16.39	06255492	2	pin
16.40	01106451	2	split pin 4 x 25
16.41	16042762	1	gasket
16.42	16042759	3	lamination
16.43	06214132	9	screw m 6 x 15, d921
16.44	01114357	9	nut m 6, d985
16.45	16042761	1	gasket
16.47	16043392	1	bracket
16.48	06207557	4	screw m 10 x 25
16.49	06214197	4	washer 10.5
16.50	06215801	2	flange eb 25
16.51	06215740	1	bearing ys 25
16.52	01112326	2	screw m 8 x 22
16.54	01102799	2	washer 8, d128
16.88	16063484	1	sump
16.89	01112341	4	screw m 8 x 30, d933
16.90	01112322	2	screw m 8 p.1.25 x 20
16.91	01107163	8	washer 9, d126
16.92	06214355	2	washer 8.4
16.93	01104944	6	nut m 8, d985

GRAIN TANK UNLOADER

Fig.	Code	QTY	Name
------	------	-----	------

Notes:

[6090 ->14500]

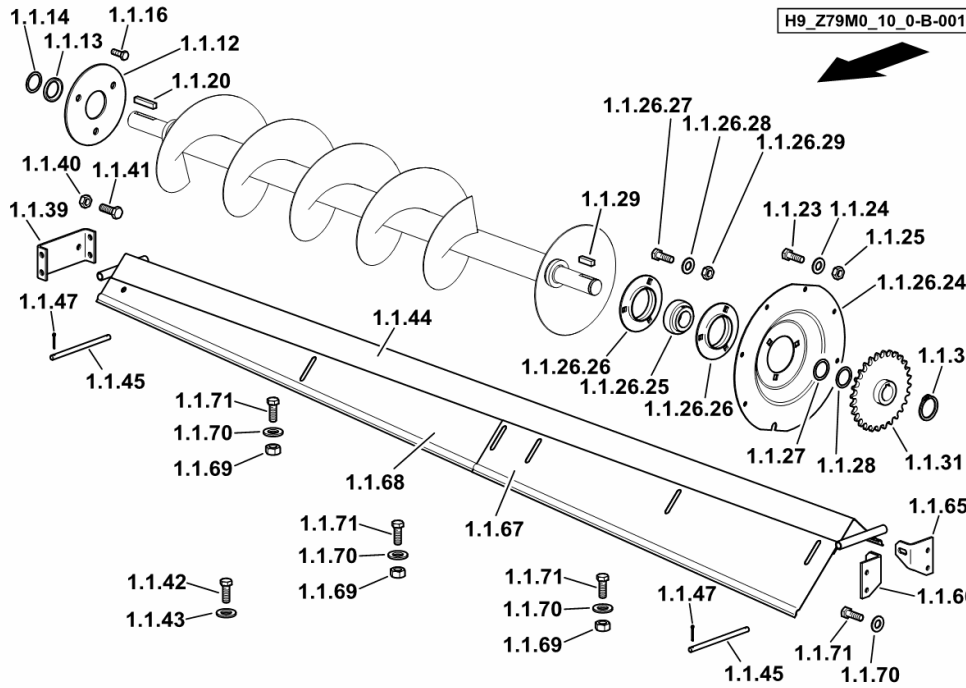

1.1.12	06505426	1	disc
1.1.13	06255488/10	1	spacer Ø 35.5 x 6.5
1.1.14	06214486	3	shim 35 x 45 x 1.0
1.1.16	01112554	3	screw m 12 x 45
1.1.20	01118083	1	dowel 10 x 8 x 56 d6885
1.1.23	01112322	2	screw m 8 p.1.25 x 20
1.1.24	01102799	7	washer 8, d128
1.1.25	01112824	7	nut m 8, d934
1.1.26.24	06511583	1	cover
1.1.26.25	06215759	2	bearing ys 35
1.1.26.26	06215784	2	flange rb 35
1.1.26.27	01151936	3	screw m 10 x 25
1.1.26.28	01102800	3	washer 10.2
1.1.26.29	01102659	3	nut m 10, d934
1.1.27	06214486	2	shim 35 x 45 x 1.0
1.1.28	06214485	2	shim 35 x 45 x 0,5
1.1.29	01101341	1	washer 10.2
1.1.30	01107748	1	ring 35 x 1.5, d471
1.1.31	06534624	1	chain wheel Z = 29
1.1.39	06279280	1	support
1.1.40	01112418	2	screw m 10 x 25, d933
1.1.41	06209768	2	nut m 10, d985
1.1.42	01112307	4	screw m 8 p.1.25 x 15, d933
1.1.43	01102799	4	washer 8, d128
1.1.44	16047067	1	lamination
1.1.45	06255506/10	2	rod Ø 10 / L = mm 173
1.1.47	01132625	4	split pin 3.2 x 20
1.1.65	06521129	1	square sx/lh/li
1.1.66	06521130	1	square dx/rh/re
1.1.67	06521144	2	lamination sx/lh/li
1.1.68	06540362	2	lamination dx/rh/re
1.1.69	06214192	12	washer 8.4
1.1.70	01102799	12	washer 8, d128
1.1.71	01112322	16	screw m 8 p.1.25 x 20

GRAIN TANK COVER

Fig.	Code	QTY	Name
21	06214980	2	rivet
22	16011808/10	4	shim mm 5.00
23	01112356	1	screw m 8 x 40
24	01107163	2	washer 9, d126
25	01103316	2	screw m 6 p.1.0 x 16
26	06214189	4	washer 6.4
27	01114357	2	nut m 6, d985

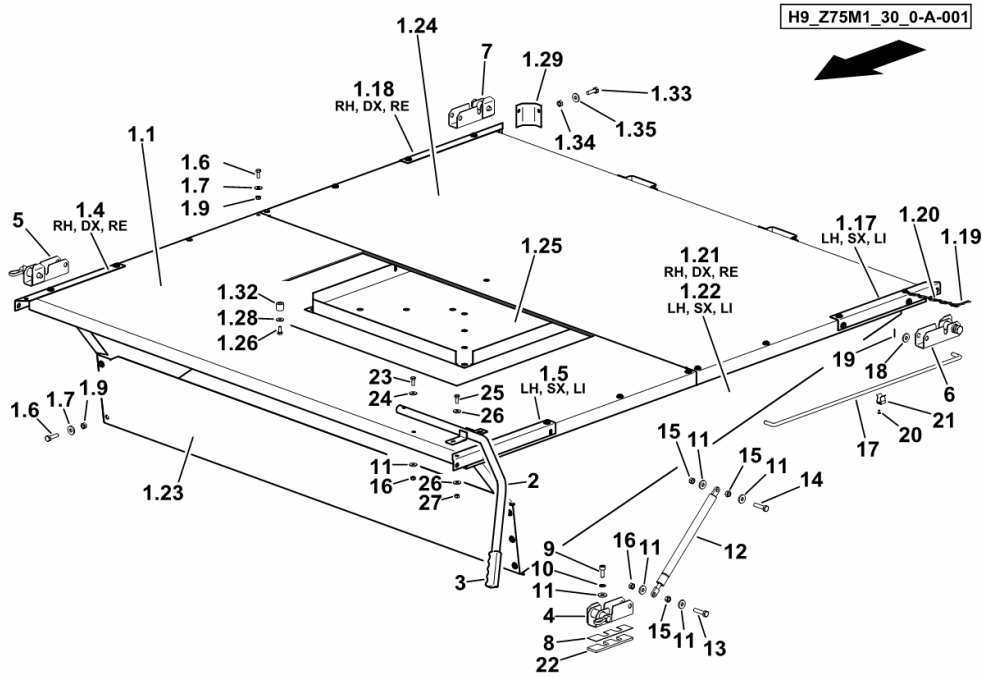

BEARING

Fig.	Code	QTY	Name
------	------	-----	------

Notes:

[6090 ->14500]

1	01120697	3	lubricator bm 8 x 1
6	01102800	16	washer 10.2
11	06523553	1	bearing kpl.
11.2	06255515	1	bushing 35 x 39 x 30
12	01112429	12	screw m 10 x 30, d933
13	06214197	8	washer 10.5
14	01102659	4	nut m 10, d934
15	01137526	4	shim 35 x 45 x 2,5
16	01107748	1	ring 35 x 1.5, d471

H9_Z57M5_30_0-C-001

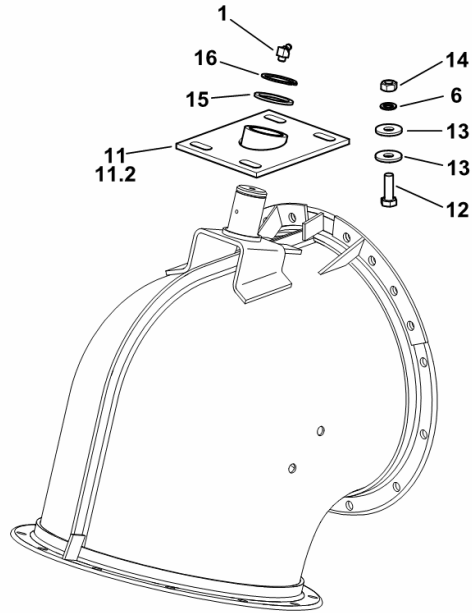

6090 ->14500

HD - HYDRAULIC SYSTEM

HYDRAULIC SYSTEM

OIL TANK AND FILTER.....	HD.01.1 (1)
HYDRAULIC SYSTEM.....	HD.01.3 (1)
OIL DRAIN PIPES.....	HD.01.5 (1)
OIL RETURN PIPE.....	HD.01.9 (1)
OIL RETURN PIPE.....	HD.01.10 (1)
HYDRAULIC PUMP - 11 CM ³	HD.01.11 (1)
VARIABLE DISPLACEMENT PUMP.....	HD.01.12 (1)
PIPING.....	HD.01.13 (1)
LUBRIC. OIL FILTER.....	HD.01.14 (1)
HYDRAULIC PUMP 135 CC.....	HD.01.16 (1)
TIE ROD FOR HYDRAULIC PUMP.....	HD.01.17 (1)
STOP.....	HD.01.22 (1)
STOP.....	HD.01.23 (1)
CLUTCH.....	HD.01.24 (1)
CLUTCH.....	HD.01.27 (1)
HYDRAULIC DRIVE SYSTEM 135 CC.....	HD.01.29 (1)
HYDRAULIC MOTOR 135 CC.....	HD.01.32 (1)
OIL COOLER PIPE.....	HD.01.34 (1)
OIL COOLER PIPE.....	HD.01.35 (1)
HYDRAULIC SYSTEM.....	HD.01.37 (1)
HYDRAULIC SYSTEM.....	HD.01.38 (1)
ACCUMULATOR BLOCK.....	HD.01.39 (1)
HYDRAULIC SYSTEM.....	HD.01.40 (1)
HYDRAULIC SYSTEM.....	HD.01.41 (1)
PIPING.....	HD.01.42 (1)
PIPING.....	HD.01.43 (1)
LIFTING CYLINDERS HYDRAULIC SYSTEM.....	HD.01.45 (1)
LIFTING CYLINDERS HYDRAULIC SYSTEM.....	HD.01.46 (1)
LIFTING CYLINDERS FOR FEED ELEVATOR.....	HD.01.47 (1)
LIFTING CYLINDERS FOR FEED ELEVATOR.....	HD.01.48 (1)
THIRD LIFTING CYLINDER FOR FEED ELEVATOR.....	HD.01.49 (1)
THIRD LIFTING CYLINDER FOR FEED ELEVATOR.....	HD.01.50 (1)
FOURTH LIFTING CYLINDER FOR FEED ELEVATOR.....	HD.01.51 (1)
FOURTH LIFTING CYLINDER FOR FEED ELEVATOR.....	HD.01.52 (1)
PLUGS.....	HD.01.53 (1)
PLUGS.....	HD.01.54 (1)
MAIN HYDRAULIC STEERING.....	HD.01.55 (1)
FASTENINGS.....	HD.01.56 (1)
HYDRAULIC SYSTEM FOR OUTLET PIPE.....	HD.01.58 (1)
EXHAUST PIPE BRACKET.....	HD.01.59 (1)

PIPING

Fig.	Code	QTY	Name
Notes:			
[6090 ->14500]			
33	04454041	1	pipe fitting Ø 22
34	0.015.7612.3/10	1	tube L = MM 1740 M30 X 2, M12 X 1.5, Ø19
35	04454508/10	1	pipe fitting Ø 8
36	0.015.7617.3	1	tube L = MM 646.4 M14 X 1.5, M12 X 1.5, Ø6
37	2.1560.016.0	1	gasket 20.2 x 26
38	04453854	1	reduction Ø 17
39	2.3249.255.2	1	pipe fitting Ø 12
40	0.015.7615.3	1	tube L = MM 108 M18 X 1.5, Ø10
41	0.016.0855.0	1	rubber sleeve
42	2.6851.001.0	2	clamp Ø 16/25
43	2.3729.696.0	3	socket

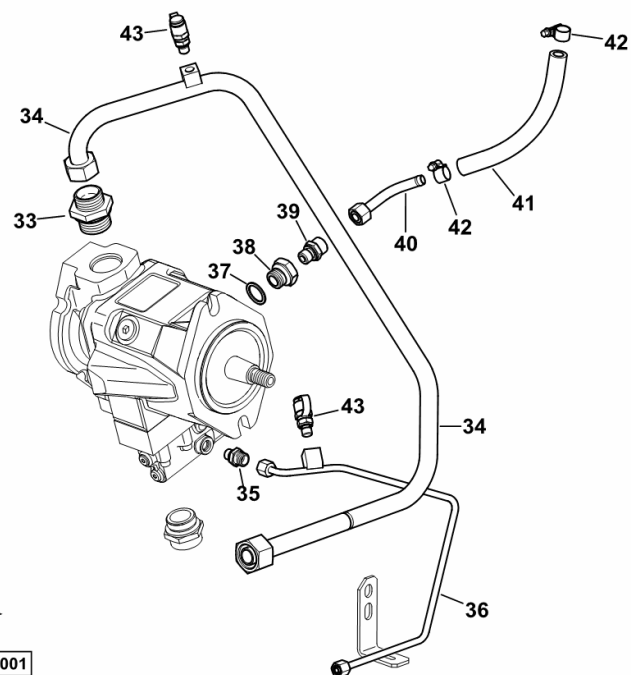

H9_Z75D2_00_0-E-001

OIL COOLER PIPE

Fig.	Code	QTY	Name
------	------	-----	------

Notes:

[6090 ->14500]

10	06513403	2	flexible hose Ø 15 - m 30 p.2 / L = mm 850
28	01102799	4	washer 8, d128
30	16048126	1	pipe fitting m 22 x 1.5
31	16040270	1	pipe fitting XEL 22-L
32	01179136	1	plug H3107 - V1L 22
33	01116656	1	pipe fitting m 30 p.2
34	16033362	1	pipe fitting geo 22-l
35	16056018	1	tube
36	16056020	1	tube
37	16022707	1	pipe fitting EW 22 L
38	06262780	3	hose clip Ø 22/22
39	01124458	3	screw m 8 x 100, d933
40	06527083	2	spacer

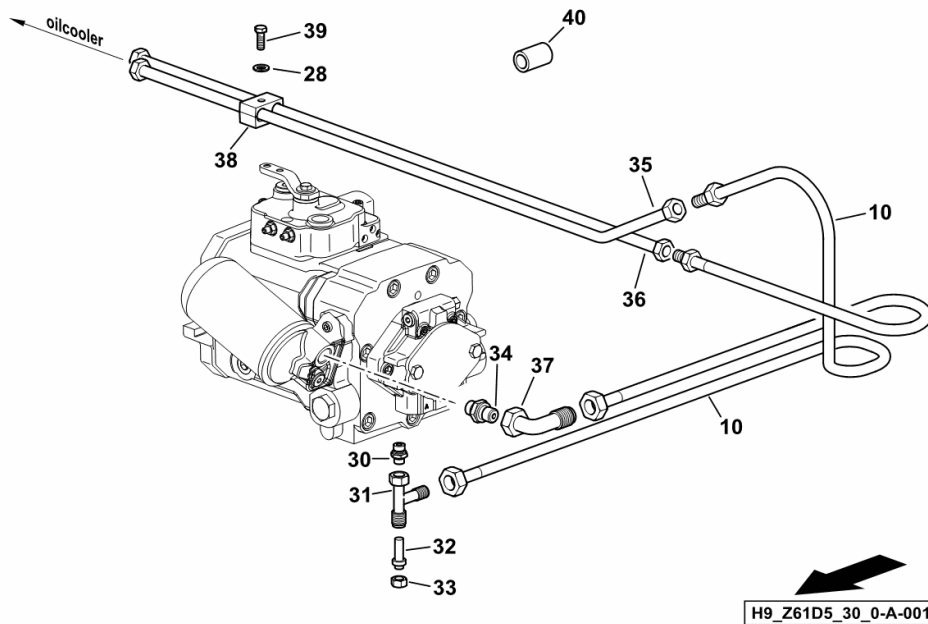

LIFTING CYLINDERS HYDRAULIC SYSTEM

Fig.	Code	QTY	Name
------	------	-----	------

Notes:
[6090 ->14500]

1	01179537	1	pipe fitting BL 12 H
2	01173028	2	pipe fitting AL 12
3	0.017.2358.3	1	tube L = MM 635 M18 X 1.5, Ø9
4	06238806	2	terminal Ø 12
5	2.0312.112.2	2	screw m 6 p.1 x 35
6	2.1480.012.2	2	washer 6, d128
7	2.1310.002.2	6	washer 6.6, d125
8	2.1011.003.2	2	nut m 6 p.1, d934
9	01143569	1	pipe fitting DL 12 H313
10	01179539	1	nut CL 12 H310
11	01179141	1	plug
12	16026609	1	tube L = MM 100 M18 X 1.5, Ø9
13	0.017.2347.0	2	bracket
14	01135936	1	pipe fitting L 12
15	2.1121.003.2	2	selflock nut m 6 p.1

H9_Z75D2_52_0-A-001

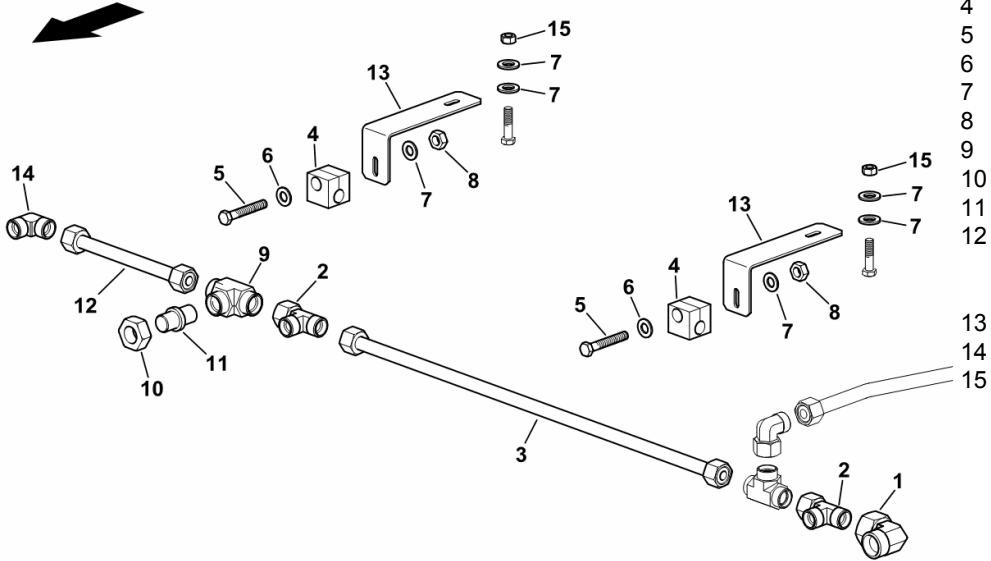

FASTENINGS

Fig.	Code	QTY	Name
------	------	-----	------

Notes:

[6090 ->14500]

5	06514682	1	bracket
8	16047336/10	1	bracket
9	16003281	2	clamp Ø 15
10	01141614	2	hose clip Ø 25/22
16	2.0114.009.2	5	screw m 6 x 25, d933
17	2.1011.003.2	5	nut m 6 p.1, d934
18	2.1474.007.2	5	washer 6, d128
19	06214189	10	washer 6.4
20	2.0114.019.2	4	screw m 6 x 60, d933
21	2.1011.003.2	8	nut m 6 p.1, d934
22	2.1474.007.2	8	washer 6, d128
23	16003289	1	bracket
24	06209258	2	screw m 8 x25, 8g
25	01112824	2	nut m 8, d934
26	01102799	1	washer 8, d128
27	16055324	1	small sump
28	01141605	1	terminal Ø 12/12
51	16047316	2	bracket
53	06261591	1	clamp 18/15
54	2.0114.217.2	1	screw m 8 p.1.25 x 50
55	16055322	2	hose clip 35/28
56	2.0112.223.2	2	screw m 8 p.1.25x70
58	01145451	1	clamp Ø 35
59	2.0112.024.2	2	screw m 6 p.1x65
60	06262780	1	hose clip Ø 22/22
61	06261603	1	terminal Ø 28/22
62	2.0112.231.2	1	screw m 8 p.1.25 x 110

H9_Z75D2_15_0-A-001

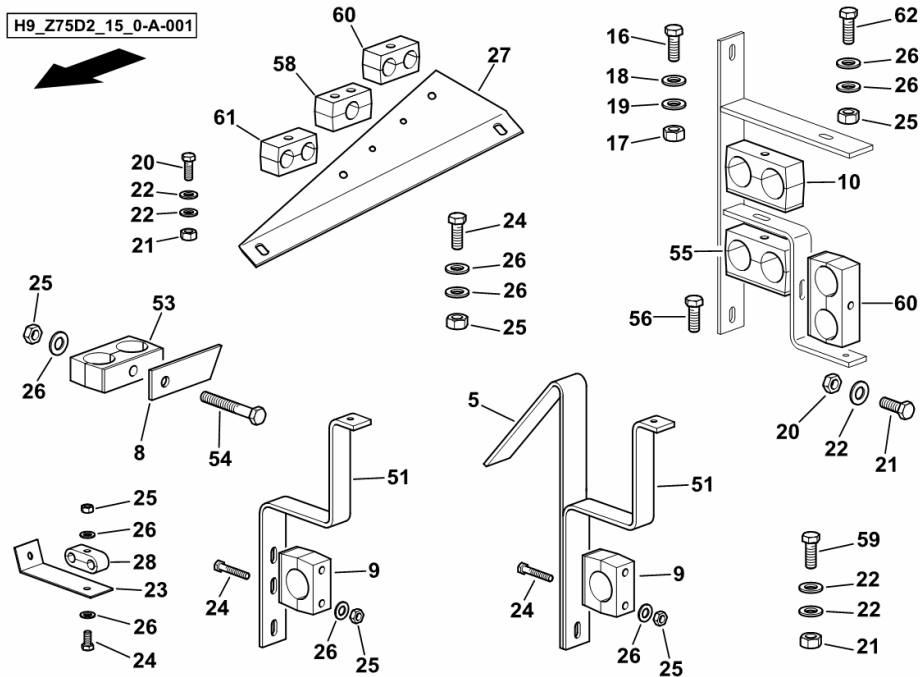

Section: HD - HYDRAULIC SYSTEM
HYDRAULIC SYSTEM

Fig.	Code	QTY	Name
------	------	-----	------

Notes:
 BALANCE/AUTOCONTROL [6090 ->14500]

1	16033384	1	pump 19 cm ³ ☞ 16033384
2	2.0114.311.2	2	screw m 10 p.1.25 x 30
3	2.1474.010.2	2	washer 10
4	16023713	1	flange Ø 22 / m 30 p.2
5	04355526	1	'o' ring Ø 24 x 2,5
6	03400563	1	flange Ø 40 / m 22 p.1.5
7	06214809	1	'o' ring 18x2,5
8	01110515	8	screw m 6 x 20
9	2.1474.007.2	8	washer 6, d128
13	0.016.5274.3	1	tube m 30 p.2
14	16050884	1	pipe fitting Ø 22 / m 30 p.2
15	06237987	1	flexible hose Ø 22.2 / L = mm 220
16	06216440	2	hose clip Ø 25/40
17	16055380	1	support
18	06238807	1	terminal Ø 22
19	06272960	1	small plate
20	2.0114.017.2	2	screw m 6 x 50
21	06272796	1	bracket PVC, Ø 28
22	2.0114.019.2	2	screw m 6 x 60, d933
23	01114357	6	nut m 6, d985
24	2.1310.002.2	4	washer 6.6, d125 (-> 14523)

H9_Z75D3_00_0-B-001

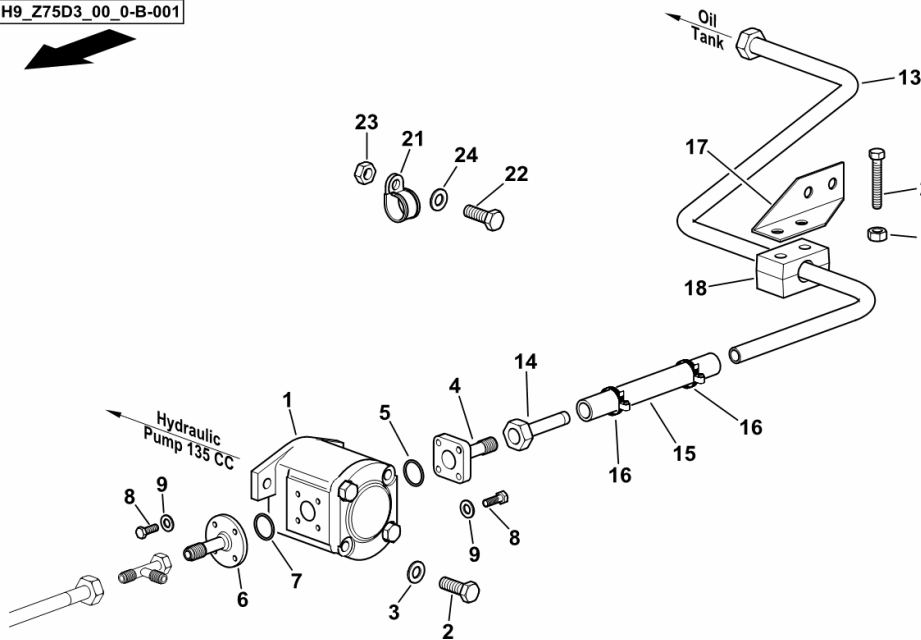

Section: HD - HYDRAULIC SYSTEM
CYLINDER PARTS Ø 45

Fig.	Code	QTY	Name
1	0.016.2179.4	1	roller Ø 45 BONDIOLI & PAVESI Ø 45, MM 418 ÷ 600 M16 X 2.5, M18 X 1.5
2	0.900.1366.8	1	gasket set

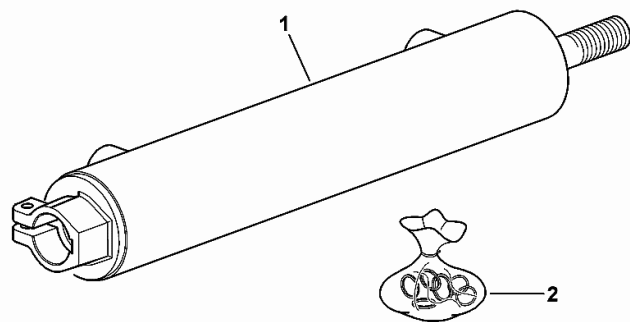

0.016.2179.4

Section: HD - HYDRAULIC SYSTEM
HYDRAULIC PUMP 19 cm³

Fig.	Code	QTY	Name
1	16033384	1	pump 19 cm ³
2	01300154	1	'o' ring 17x30x7/8
3	01107817	1	circlip
4	01263181	1	gasket set

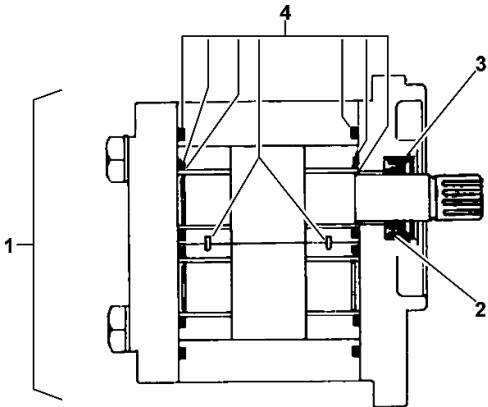

1603_3384

Section: HD - HYDRAULIC SYSTEM
STEERING HYDRAULIC

Fig.	Code	QTY	Name
------	------	-----	------

Notes:

[6090 ->14500]

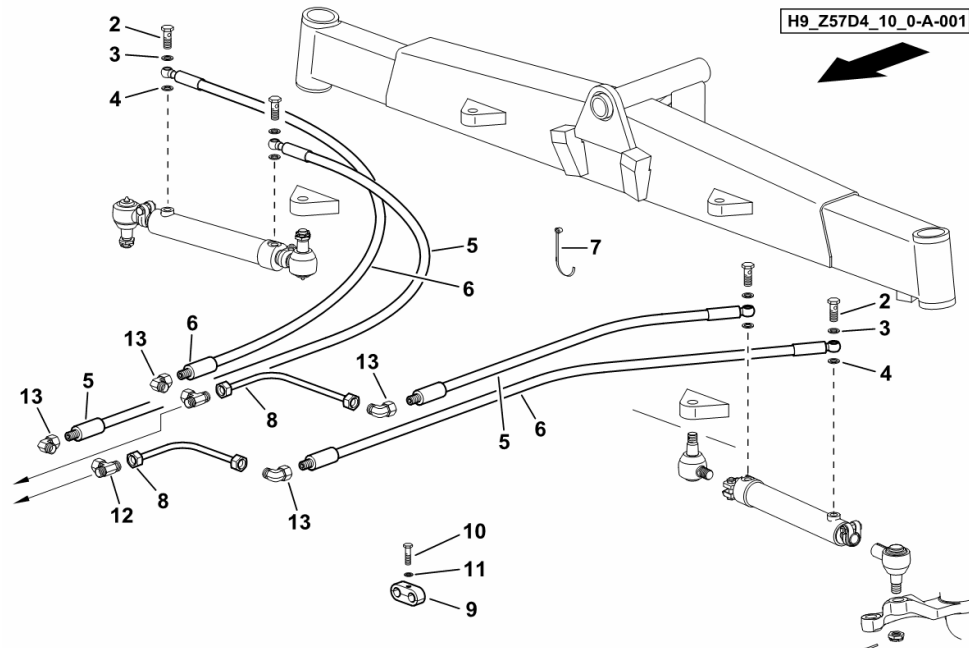

2	01137064	4	pipe union m 16 p.1.5
3	01172949	4	'o' ring 16.7
4	16034317	4	ring dka 16
5	06544368	2	tube Ø 10 / L = mm 700
6	06546466	2	tube Ø 10 / L = mm 1000
7	01172065	6	clamp 4.6 x 146
8	16006133	2	tube
9	01141605	2	terminal Ø 12/12
10	2.0114.013.2	2	screw m 6 p.1 x 35
11	2.1474.007.2	2	washer 6, d128
12	01179538	2	pipe fitting CL 12 S
13	01179537	4	pipe fitting BL 12 H

Section: HD - HYDRAULIC SYSTEM
SOLENOID VALVE ASSEMBLY - 4 X

Fig.	Code	QTY	Name
------	------	-----	------

Notes:

[6090 ->14500]

1	0.015.9249.4/10	1	hydraulic control bl (EV) - HORIZONTAL REEL - GRAIN DISCHARGE PIPE - GRAIN TANK EXTENSION - VERTICAL REEL ☞ 0.015.9249.4/10
2	2.0112.005.2	4	screw m 6 p.1 x 16
3	2.1470.002.2	4	washer 6, d128

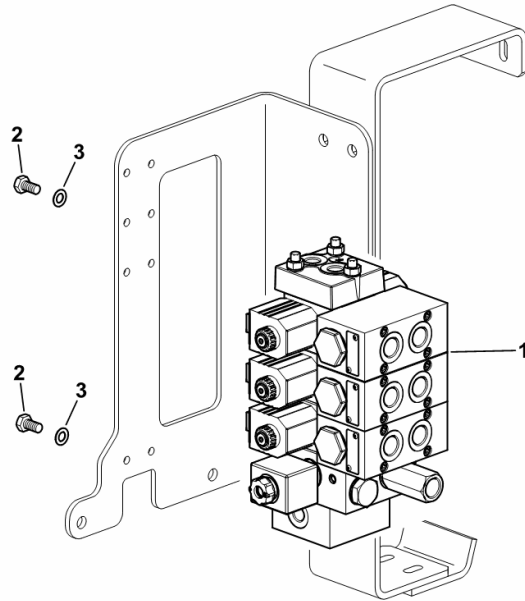

 H9_Z79D2_12_0-A-001

Section: HD - HYDRAULIC SYSTEM
VALVE ASSEMBLY PARTS - 5 X

Fig.	Code	QTY	Name
1	0.900.1410.4	0	small block
2	0.000.0000.1	0	not serviceable
3	0.000.0000.1	0	not serviceable
4	0.000.0000.1	0	not serviceable
5	0.900.1411.8	0	tip
6	0.900.1410.5	1	parts set QTY. 3: NUTS, WASHERS AND TIE-RODS (M8 X 275)
7	0.900.1410.6	4	parts set QTY. 4: BOLTS AND WASHERS
8	0.900.1410.7	6	gasket set FLANGE GASKETS
9	0.900.1410.8	1	sleeve Ø 3,0
10	0.900.1410.9	1	sleeve Ø 1,7
11	0.900.1411.9	0	sleeve Ø 1,35
12	0.900.1411.0	1	sleeve Ø 1,2
13	0.000.0000.1	0	not serviceable
14	0.900.1411.1	1	socket - PRESSURE TEST POINT
15	0.900.1411.2	1	gasket
16	0.900.1411.3	1	small column m 18 x 1,5
17	0.900.1411.4	8	coil
18	0.900.1411.5	8	gasket set PLUG INCLUDED
19	0.900.1411.6	2	coil
20	0.900.1411.7	2	nut

0.015.6091.4_20

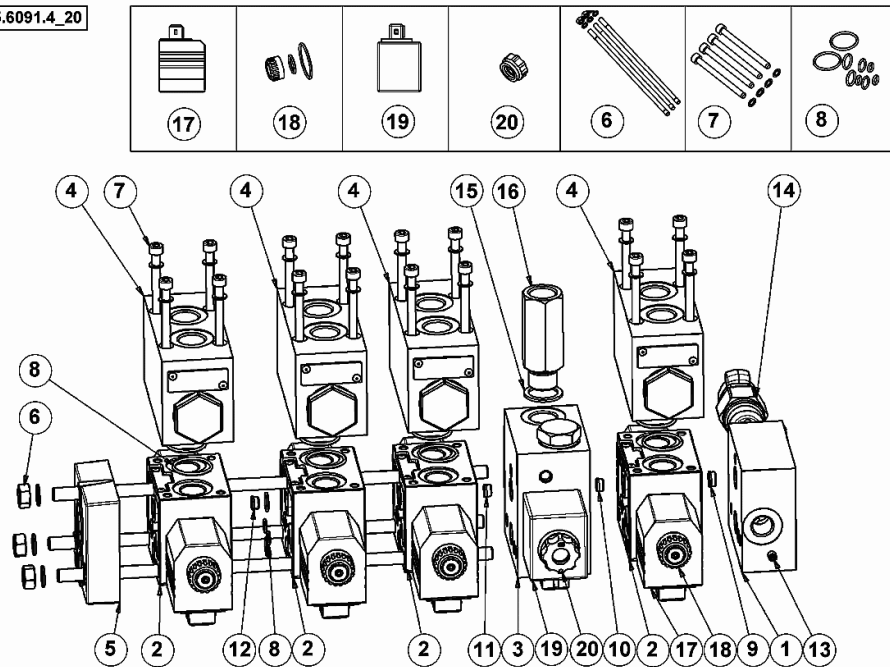

STONE TRAP

Fig.	Code	QTY	Name
------	------	-----	------

Notes:

- C.C.M. EQUIPMENT [6090 ->14500]

1.4	16005646	1	hinge
1.6.1	16048492	1	lamination
1.6.4	16040578	1	guard
1.6.6	16040599	1	lamination
1.6.7	01112322	8	screw m 8 p.1.25 x 20
1.6.8	01104944	8	nut m 8, d985
1.8	16005295	1	pin Ø 11 / L = mm 1504
1.9	01112429	12	screw m 10 x 30, d933
1.10	06209768	12	nut m 10, d985

H9_97348_60_0-A-001

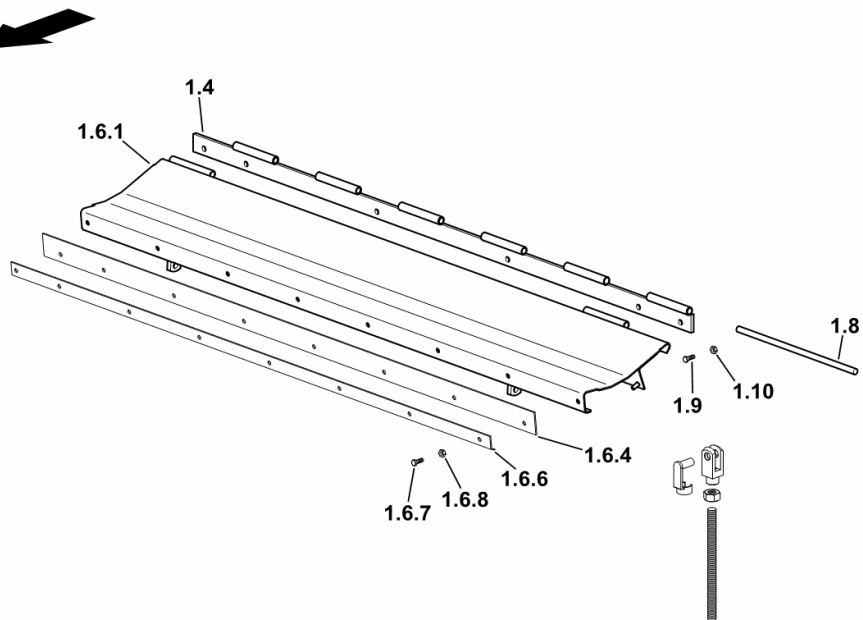

THRESHING DRUM VARIATOR CONTROL DEVICE

Fig.	Code	QTY	Name
------	------	-----	------

Notes:

[6090 ->14500]

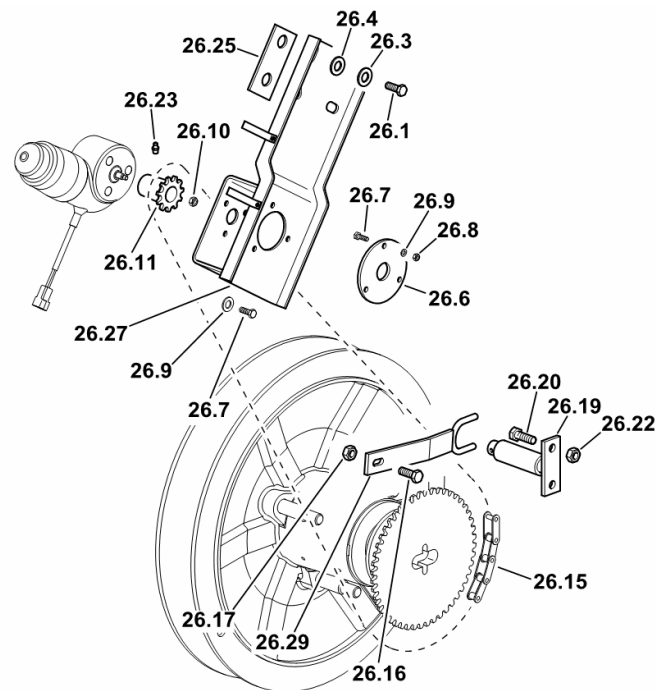

26.1	01112429	4	screw m 10 x 30, d933
26.3	01102800	4	washer 10.2
26.4	01127538	4	washer 10.5
26.6	06541374	1	disc
26.7	01112264	6	screw m 6 x 20, d933
26.8	01112813	3	nut m 6
26.9	01102797	6	washer 6, d128
26.10	01114357	1	nut m 6, d985
26.11	06513112	1	chain wheel Z = 11
26.15	01145072	1	chain 085-1x 68-E
26.16	01112333	1	screw m 8 x 25, d933
26.17	01104944	1	nut m 8, d985
26.19	06512932	1	support
26.20	01112418	6	screw m 10 x 25, d933
26.22	06209768	2	nut m 10, d985
26.23	01120692	1	lubricator am 6
26.25	06530423	4	small plate
26.27	16003966	1	support
26.29	16003984	1	bracket



H9_Z7900_21_2-E-001

MAIZE GUARD

Fig.	Code	QTY	Name
------	------	-----	------

Notes:

- MAIZE EQUIPMENT [6090 ->14500]

1	06276318	1	guard
2	06282969	1	guard
3	06256042	1	lamination
4	06282965	1	lamination
5	06282970	1	lamination
6	06256041	1	lamination
7	01112322	4	screw m 8 p.1.25 x 20
8	01102799	16	washer 8, d128
9	01112824	16	nut m 8, d934
10	01112341	12	screw m 8 x 30, d933
11	01112529	2	screw m 12 x 30, d933
12	06209769	2	nut m 12, d985

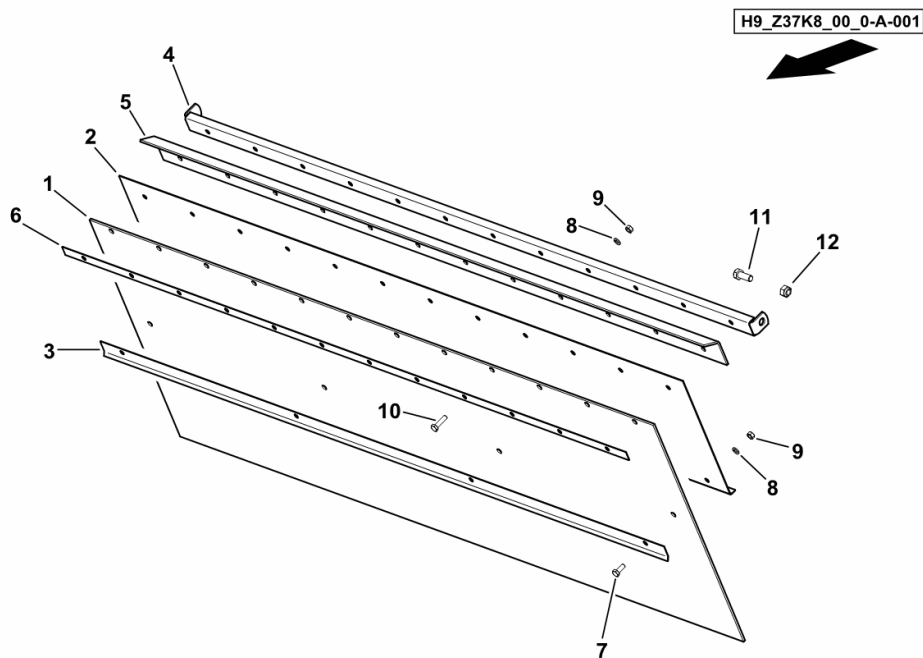

MULTI-SEGMENT CONCAVE T11 - T14 - T28

Fig.	Code	QTY	Name
------	------	-----	------

Notes:

[6090 ->14500]

1	0.015.8031.4/20	1	grille # 1
2	0.015.7981.3/10	1	threshing basket # 2
3	16052685/10	1	grille # 3
4	0.015.5613.3	1	rod
5	0.015.5587.0	1	lamination
6	01112322	3	screw m 8 p.1.25 x 20
7	01104944	1	nut m 8, d985
8	01102799	2	washer 8, d128
9	01107163	2	washer 9, d126

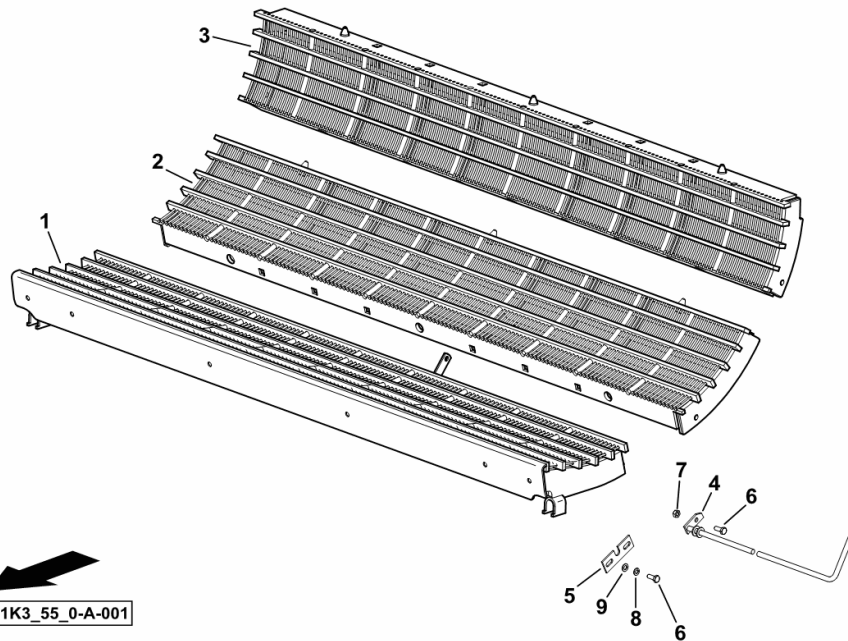

H9_Z61K3_55_0-A-001

CLICK HERE TO **DOWNLOAD** THE COMPLETE MANUAL

- Thank you very much for reading the preview of the manual.
- You can download the complete manual from: www.heydownloads.com by clicking the link below



- Please note: If there is no response to CLICKING the link, please download this PDF first and then click on it.

CLICK HERE TO **DOWNLOAD** THE COMPLETE MANUAL